

2007 Hummer H3

2007 TRANSMISSION Automatic Transmission - 4L60-E/4L65-E/4L70-E - H3

2007 TRANSMISSION

Automatic Transmission - 4L60-E/4L65-E/4L70-E - H3

SYMPTOMS - AUTOMATIC TRANSMISSION

SYMPTOMS - AUTOMATIC TRANSMISSION

Symptom Diagnosis

Diagnostic Category	Diagnostic Information
DEFINITION: This table consists of 9 diagnostic categories that are located in the left column. Using this column, choose the appropriate category based on the operating conditions of the vehicle or transmission. After selecting a category, use the right column to locate the specific symptom diagnostic information.	
Fluid Diagnosis: This category contains the following topics: <ul style="list-style-type: none">• Fluid condition: appearance, contaminants, smell, overheating• Line pressure: high or low• Fluid leaks	<ul style="list-style-type: none">• Refer to <u>Transmission Fluid Check</u>.• Refer to <u>Oil Pressure High or Low</u>.• Refer to <u>Fluid Leak Diagnosis</u>.• Refer to <u>Oil Out the Vent</u>.
Noise and Vibration Diagnosis: This category contains the following topics: <ul style="list-style-type: none">• Ratcheting noise• Noise: drive gear, final drive, whine, growl, rattle, buzz, popping• Vibration	<ul style="list-style-type: none">• Refer to <u>Ratcheting Noise</u>.• Refer to <u>Ticking Noise in Reverse</u>.• Refer to <u>Vibration in Reverse and Whining Noise in Park</u>.• Refer to <u>Popping Noise</u>.• Refer to <u>Whine Noise Varying with RPM or Fluid Pressure</u>.• Refer to <u>Buzz Noise or High Frequency Rattle Sound</u>.• Refer to <u>Noise in Random Ranges</u>.
Range Performance Diagnosis: This category contains the following topics: <ul style="list-style-type: none">• Drives in Neutral• No Park• No Reverse	<ul style="list-style-type: none">• Refer to <u>Drives in Neutral</u>.• Refer to <u>No Park</u>.• Refer to <u>No Reverse or Slips in Reverse</u>.• Refer to <u>No Drive in All Ranges</u>.

2007 Hummer H3

2007 TRANSMISSION Automatic Transmission - 4L60-E/4L65-E/4L70-E - H3

<ul style="list-style-type: none">• No Drive• No engine braking• Shift selector indicator does not match transmission gear range• Lack of power or hesitation	<ul style="list-style-type: none">• Refer to <u>No Drive in Drive Range</u>.• Refer to <u>No Overrun Braking - Manual 3-2-1</u>.• Refer to <u>Range Selector Displays Incorrect Range</u>.• Refer to <u>Lack of Power or Hesitation</u>.
<p>Shift Quality (Feel) Diagnosis: This category contains the following topic:</p> <ul style="list-style-type: none">• Harsh, soft or slipping shifts• Harsh, soft or delayed engagement• Shift shudder, flare or tie-up	<ul style="list-style-type: none">• Refer to <u>Harsh Shifts</u>.• Refer to <u>Slipping or Harsh 1-2 Shift</u>.• Refer to <u>No 2-3 Shift or 2-3 Shift Slips, Rough or Hunting</u>.• Refer to <u>No 3-4 Shift, Slips or Rough 3-4 Shift</u>.• Refer to <u>Harsh Garage Shift</u>.• Refer to <u>Delay in Drive and Reverse</u>.• Refer to <u>3-2 Flare or Tie-Up</u>.
<p>Shift Pattern: This category contains the following topics:</p> <ul style="list-style-type: none">• One forward gear only• Two forward gears only• Gear missing or slipping• No upshift or slipping upshift• No downshifts• Non-First gear start	<ul style="list-style-type: none">• Refer to <u>First Gear Range Only - No Upshift</u>.• Refer to <u>Third Gear Only</u>.• Refer to <u>Second/Third Gear Only or First/Fourth Gears Only</u>.• Refer to <u>Slips in First Gear</u>.• Refer to <u>Slipping or Harsh 1-2 Shift</u>.• Refer to <u>No 2-3 Shift or 2-3 Shift Slips, Rough or Hunting</u>.• Refer to <u>No 3-4 Shift, Slips or Rough 3-4 Shift</u>.• Refer to <u>No Part Throttle or Delayed Downshifts</u>.• Refer to <u>Second Gear Start</u>.
<p>Shift Speed Diagnosis: This category contains the following topic: Inaccurate or inconsistent shift points</p>	Refer to <u>Inaccurate Shift Points</u> .
<p>Torque Converter Diagnosis: This category contains the following topics:</p>	<ul style="list-style-type: none">• Refer to <u>Torque Converter Diagnosis</u>.

Circuit Description

The transmission range (TR) switch is part of the park/neutral position (PNP) and back-up lamp switch assembly, which is externally mounted on the transmission manual shaft. The TR switch contains four internal switches that indicate the transmission gear range selector lever position. The powertrain control module (PCM) supplies ignition voltage to each switch circuit. As the gear range selector lever is moved, the state of each switch may change, causing the circuit to open or close. An open circuit or switch indicates a high voltage signal. A closed circuit or switch indicates a low voltage signal. The PCM detects the selected gear range by deciphering the combination of the voltage signals. The PCM compares the actual voltage combination of the switch signals to a TR switch combination chart stored in memory.

Diagnostic Aids

Refer to the **Transmission Range Switch Logic** table for valid combinations of switch signal circuits A, B, C and Parity. On the table, HI indicates an ignition voltage signal. LOW indicates a zero voltage signal.

Test Description

The numbers below refer to the step numbers on the diagnostic table.

- 4:** By disconnecting the TR switch, the ground path of all TR switch circuits is removed and the PCM should recognize all circuits as open. The scan tool should display HI for all range signal states.
- 5:** This step tests the TR switch wiring for an open or the lack of the signal voltage from the PCM.
- 6:** This step tests the TR switch wiring and the PCM by providing a ground path through a fused jumper wire. When grounded, the scan tool range signal states should change to LOW.
- 7:** This step tests the TR switch wiring and the PCM by providing a ground path through a fused jumper wire. When grounded, the scan tool range signal states should change to LOW.
- 8:** This step tests the TR switch wiring and the PCM by providing a ground path through a fused jumper wire. When grounded, the scan tool range signal states should change to LOW.
- 9:** This step tests the TR switch wiring and the PCM by providing a ground path through a fused jumper wire. When grounded, the scan tool range signal states should change to LOW.

Range Selector Displays Incorrect Range

Step	Action	Values	Yes	No
	1. Install a scan tool.			

2007 Hummer H3

2007 TRANSMISSION Automatic Transmission - 4L60-E/4L65-E/4L70-E - H3

1	<p>2. Turn ON the ignition, with the engine OFF.</p> <p>3. Select TR Sw. on the scan tool.</p> <p>4. With the scan tool, observe the TR Sw. display while selecting each transmission range: P, R, N, D4, D3, D2 and D1.</p> <p>Does each selected transmission range match the scan tool TR Sw. display?</p>	-	Go to Step 2	Go to Step 3
2	<p>Observe the instrument panel cluster (IPC) gear range display while selecting each transmission range: P, R, N, D4, D3, D2, D1.</p> <p>Does each selected transmission range match the IPC display?</p>	-	Go to <u>Testing for Intermittent Conditions and Poor Connections</u>	Go to Step 16
3	<p>With the scan tool, observe the TR Sw. A/B/C/P display.</p> <p>Does the scan tool TR Sw. A/B/C/P parameter indicate HI for all range signal states?</p>	-	Go to Step 13	Go to Step 4
4	<p>1. Turn OFF the ignition.</p> <p>2. Disconnect the TR switch connector.</p> <p>3. Turn ON the ignition, with the engine OFF.</p> <p>Does the scan tool TR Sw. A/B/C/P parameter indicate HI for all range signal states?</p>	-	Go to Step 5	Go to Step 10
	<p>1. Using the DMM and the J 35616 Terminal Test Kit, measure the voltage from the signal A circuit of the TR switch connector to ground.</p>			

2007 Hummer H3

2007 TRANSMISSION Automatic Transmission - 4L60-E/4L65-E/4L70-E - H3

5	<p>2. Measure the voltage from the signal B circuit of the TR switch connector to ground.</p> <p>3. Measure the voltage from the signal C circuit of the TR switch connector to ground.</p> <p>4. Measure the voltage from the signal P circuit of the TR switch connector to ground.</p> <p>Does the voltage measure within the specified value at all four circuits?</p>	10-12 V	Go to Step 6	Go to Step 11
6	<p>Connect a fused jumper wire from the TR switch connector, signal circuit A, to ground while monitoring the scan tool TR Sw. A/B/C/P parameter.</p> <p>When signal circuit A is grounded, do any other signal circuits indicate LOW?</p>	-	Go to Step 12	Go to Step 7
7	<p>Connect a fused jumper wire from the TR switch connector, signal circuit B, to ground while monitoring the scan tool TR Sw. A/B/C/P parameter.</p> <p>When signal circuit B is grounded, do any other signal circuits indicate LOW?</p>	-	Go to Step 12	Go to Step 8
8	<p>Connect a fused jumper wire from the TR switch connector, signal circuit C, to ground while monitoring the scan tool TR Sw. A/B/C/P parameter.</p> <p>When signal circuit C is grounded, do any other signal circuits indicate LOW?</p>	-	Go to Step 12	Go to Step 9
	<p>Connect a fused jumper wire from the TR switch connector, signal circuit P, to ground while</p>			

2007 Hummer H3

2007 TRANSMISSION Automatic Transmission - 4L60-E/4L65-E/4L70-E - H3

9	<p>monitoring the scan tool TR Sw. A/B/C/P parameter. When signal circuit P is grounded, do any other signal circuits indicate LOW?</p>	-	Go to Step 12	Go to Step 13
10	<p>Test the signal circuits of the TR switch that did not indicate HI for a short to ground. Refer to <u>Circuit Testing</u> and <u>Wiring Repairs</u> . Did you find and correct the condition?</p>	-	Go to Step 17	Go to Step 15
11	<p>Test the signal circuits of the TR switch that did not indicate proper voltage for an open. Refer to <u>Circuit Testing</u> and <u>Wiring Repairs</u> . Did you find and correct the condition?</p>	-	Go to Step 17	Go to Step 15
12	<p>Test the affected signal circuits of the TR switch for a shorted together condition. Refer to <u>Circuit Testing</u> and <u>Wiring Repairs</u> . Did you find and correct the condition?</p>	-	Go to Step 17	Go to Step 15
13	<p>Test the ground circuit of the TR switch for an open. Refer to <u>Circuit Testing</u> and <u>Wiring Repairs</u> . Did you find and correct the condition?</p>	-	Go to Step 17	Go to Step 14
14	<p>Replace the TR switch, this switch is part of the park/neutral position switch. Refer to <u>Park/Neutral Backup Switch Replacement</u>. Did you complete the replacement?</p>	-	Go to Step 17	-
15	<p>Replace the PCM. Refer to <u>Control Module References</u> . Did you complete the replacement?</p>	-	Go to Step 17	-
	<p>Replace the IPC. Refer to <u>Control</u></p>			

2007 Hummer H3

2007 TRANSMISSION Automatic Transmission - 4L60-E/4L65-E/4L70-E - H3

16	Module References . Did you complete the replacement?	-	Go to Step 17	Go to Step 2
17	1. Turn ON the ignition, with the engine OFF. 2. With the scan tool, observe the TR Sw. display while selecting each transmission range: P, R, N, D4, D3, D2 and D1. Does each selected transmission range match the scan tool TR Sw. display?	-	System OK	Go to Step 2

TRANSMISSION FLUID CHECK

This procedure checks the transmission fluid level, as well as the condition of the fluid itself.

NOTE: Always use the proper automatic transmission fluid listed. Using incorrect automatic transmission fluid may damage the vehicle.

Before checking the fluid level, perform the following:

1. Start the engine and park the vehicle on a level surface. Keep the engine running.
2. Apply the parking brake and place the shift lever in PARK (P).
3. Depress the brake pedal and move the shift lever through each gear range, pausing for about 3 seconds in each range. Then, move the shift lever back to PARK (P).
4. Allow the engine to idle 500-800 RPM for at least 1 minute. Slowly release the brake pedal.
5. Keep the engine running and observe the transmission fluid temperature (TFT) using the Driver Information Center (DIC) or a scan tool.
6. Using the TFT reading, determine and perform the appropriate check procedure. If the TFT reading is not within the required temperature ranges, allow the vehicle to cool or operate the vehicle until the appropriate TFT is reached.

Cold Check Procedure

IMPORTANT: Use the cold check procedure only as a reference to determine if the transmission has enough fluid to be

operated safely until a hot check procedure can be made. The hot check procedure is the most accurate method to check the fluid level. Perform the hot check procedure at the first opportunity.

Use this cold check procedure to check fluid level when the TFT is between 27-32°C (80-90°F).

1. Start the engine and locate the transmission dipstick at the rear of the engine compartment, on the passenger's side of the vehicle.
2. Flip the handle up and then pull out the dipstick and wipe the dipstick end with a clean rag or paper towel.
3. Install the dipstick by pushing it back in the dipstick tube all the way, wait three seconds and then pull it back out again.

IMPORTANT: Always check the fluid level at least twice. Consistent readings are important to maintaining proper fluid level. If inconsistent readings are noted, inspect the transmission vent assembly to ensure it is clean and unclogged.

4. Keep the dipstick pointing down and check both sides of the dipstick and read the lower level. Repeat the check procedure to verify the reading.
5. Inspect the color of the fluid on the dipstick. Refer to Fluid Condition Inspection in this procedure.
6. If the fluid level is below the COLD check line, add only enough fluid as necessary to bring the level into the COLD line. It does not take much fluid, generally less than one pint (0.5L). Do not overfill.
7. If the fluid level is in the acceptable range, push the dipstick back in all the way, then flip the handle down to lock the dipstick in place.
8. Perform a hot check at the first opportunity after the transmission reaches a normal operating temperature between 82-93°C (180-200°F).

Hot Check Procedure

IMPORTANT: Use this procedure to check the transmission fluid level when the TFT is between 82-93°C (180-200°F). The hot check procedure is the most accurate method to check the fluid level. The hot check should be performed at the first opportunity in order to verify the cold check. The fluid level

rises as fluid temperature increases, so it is important to ensure the transmission temperature is within range.

1. Start the engine and locate the transmission dipstick at the rear of the engine compartment, on the passenger side of the vehicle.
2. Flip the handle up and then pull out the dipstick and wipe the dipstick end with a clean rag or paper towel.
3. Install the dipstick by pushing it back in the dipstick tube all the way, wait three seconds and then pull it back out.

IMPORTANT: Always check the fluid level at least twice. Consistent readings are important to maintaining proper fluid level. If inconsistent readings are noted, inspect the transmission vent assembly to ensure it is clean and unclogged.

4. Keep the dipstick tip pointing down and check both sides of the dipstick. Read the lower level. Repeat the check procedure to verify the reading.
5. Inspect the color of the fluid on the dipstick. Refer to **Fluid Condition Inspection**.
6. A safe operating fluid level is within the HOT crosshatch band on the dipstick. If the fluid level is not within the HOT band and the transmission temperature is between 82-93°C (180-200°F), add or drain fluid as necessary to bring the level into the HOT band. If the fluid level is low, add only enough fluid to bring the level into the HOT band.

IMPORTANT: To assist in reaching the correct temperature range of 82-93°C (180-200°F), drive the vehicle in second gear at no more than 65 mph until the desired temperature is reached.

7. If the fluid level is low, add only enough fluid to bring the level into the HOT band. It does not take much fluid, generally less than one pint (0.5L). Do not overfill. Also, if the fluid level is low, inspect the transmission for leaks. Refer to **Fluid Leak Diagnosis**.
8. If the fluid level is in the acceptable range, push the dipstick back into the dipstick tube all the way and then flip the handle down to lock the dipstick in place.
9. If applicable and if the vehicle is equipped, reset the transmission oil life monitor only if the fluid was changed.

Fluid Condition Inspection

Inspect the fluid color. The fluid should be red or dark brown.

- If the fluid color is very dark or black and has a burnt odor, inspect the fluid and inside of the bottom pan for excessive metal particles or other debris. A small amount of "friction" material in the bottom pan is a "normal" condition. If large pieces and/or metal particles are noted in the fluid or bottom pan, flush the oil cooler and cooler lines and overhaul the transmission. If there are no signs of transmission internal damage noted, replace the fluid filter assembly, repair the oil cooler and flush the cooler lines.
- Fluid that is cloudy or milky or appears to be contaminated with water indicates engine coolant or water contamination. Refer to **Engine Coolant/Water in Transmission**.

LINE PRESSURE CHECK

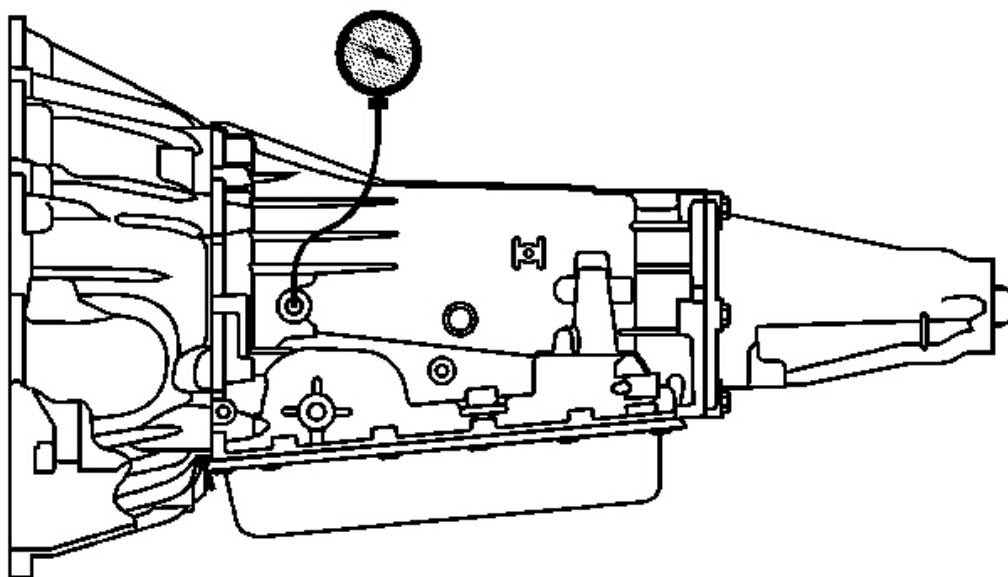

Fig. 2: Using Pressure Gage To Test Line Pressure
Courtesy of GENERAL MOTORS CORP.

Tools Required

J 21867 Pressure Gage

Check Procedure

CAUTION: Keep the brakes applied at all times in order to prevent

unexpected vehicle motion. Personal injury may result if the vehicle moves unexpectedly.

IMPORTANT: Before performing the line pressure check, verify that the transmission pressure control (PC) solenoid is operating correctly.

1. Install a scan tool.
2. Start the engine.
3. Inspect the transmission for the proper fluid levels. Refer to **Transmission Fluid Check**.
4. Use the scan tool to inspect for any active or stored diagnostic trouble codes.
5. Inspect the manual linkage at the transmission for proper function.
6. Turn the engine OFF.

IMPORTANT: It may be necessary to remove or disconnect components in order to gain access to the transmission line pressure test port/plug.

7. Remove the pressure plug.
8. Install the **J 21867**.
9. Access the Scan Tool Output Control for the PC Solenoid.
10. Start the engine.

IMPORTANT: In order to achieve accurate line pressure readings, the following procedure must be performed at least three times in order to gather uniform pressure readings.

The scan tool is only able to control the PC solenoid in PARK and NEUTRAL with engine speeds below 1500 RPM. This protects the clutches from extreme high or low line pressures.

This test must be performed at 1200 RPM, between 38-93°C (100-200°F).

11. Begin commanding PC Solenoid at 1.0 amp and lower the amperage in one-tenth increments (0.01) until maximum line pressure is achieved.
12. Allow the pressure to stabilize between increments.
13. Compare your pressure readings to the Line Pressure table. Refer to **Line Pressure**.

14. If the pressure readings vary greatly from the line pressure table, refer to **Oil Pressure High or Low**.
15. Turn the engine OFF.
16. Remove the **J 21867** .

NOTE: Refer to **Fastener Notice** .

17. Install the pressure plug.

Tighten: Tighten the pressure plug to 8-14 N.m (6-10 lb ft).

ROAD TEST

IMPORTANT: The Road Test Procedure should be performed only as part of the **Symptom Diagnosis**. Refer to **Symptoms - Automatic Transmission**.

The following test provides a method of evaluating the condition of the automatic transmission. The test is structured so that most driving conditions would be achieved. The test is divided into the following parts:

- Electrical Function Check
- Upshift Control and Torque Converter Clutch (TCC) Apply
- Part Throttle Detent Downshifts
- Full Throttle Detent Downshifts
- Manual Downshifts
- Coasting Downshifts
- Manual Gear Range Selection
 - REVERSE
 - Manual FIRST
 - Manual SECOND
 - Manual THIRD

IMPORTANT: Complete the test in the sequence given. Incomplete testing cannot guarantee an accurate evaluation.

Before the road test, ensure the following:

2007 Hummer H3

2007 TRANSMISSION Automatic Transmission - 4L60-E/4L65-E/4L70-E - H3

- The engine is performing properly.
- Transmission fluid level is correct. Refer to the **Transmission Fluid Check**.
- Tire pressure is correct.

During the road test:

- Perform the test only when traffic conditions permit.
- Operate the vehicle in a controlled, safe manner.
- Observe all traffic regulations.
- View the scan tool data while conducting this test.

Take along qualified help in order to operate the vehicle safely.

- Observe any unusual sounds or smells.

After the road test, check the following:

- Transmission fluid level-Refer to the **Transmission Fluid Check**.
- Diagnostic trouble codes (DTCs) that may have set during the testing-Refer to the applicable DTC.
- Scan tool data for any abnormal readings or data.

Electrical Function Check

Perform this check first, in order to ensure the electronic transmission components are connected and functioning properly. If these components are not checked, a simple electrical condition could be mis-diagnosed.

1. Connect the scan tool.
2. Ensure the gear selector is in PARK and set the parking brake.
3. Start the engine.
4. Verify that the following scan tool data can be obtained and is functioning properly.

Refer to **Scan Tool Data List** for typical data values. Data that is questionable may indicate a concern.

- Engine speed
- Transmission output speed

- Transmission input speed - some models
- Vehicle speed
- TFP manual valve position switch
- Transmission range
- Commanded gear
- PC solenoid reference current
- PC solenoid actual current
- PC solenoid duty cycle
- Engine coolant temperature
- Transmission fluid temperature
- Throttle angle
- Ignition voltage
- 1-2 shift solenoid
- 2-3 shift solenoid
- TCC solenoid duty cycle
- TCC slip speed

5. Check the garage shifts.

1. Apply the brake pedal and ensure that the parking brake is set.
2. Move the gear selector through the following ranges:
 1. PARK to REVERSE
 2. REVERSE to NEUTRAL
 3. NEUTRAL to DRIVE
3. Pause 2-3 seconds in each gear position.
4. Verify the gear engagements are immediate and not harsh.

IMPORTANT: Harsh engagement may be caused by any of the following conditions:

- **High idle speed-Compare engine idle speed to desired idle speed.**
- **Commanded low PC solenoid current-Compare PC solenoid reference current to PC solenoid actual current.**
- **A default condition caused by certain DTCs that result in maximum line pressure to prevent slippage**

- **Low transmission fluid temperature**

IMPORTANT: Soft or delayed engagement may be caused by any of the following conditions:

- **Low idle speed-Compare engine idle speed to desired idle speed.**
- **Low fluid level**
- **Commanded high PC solenoid current-Compare PC solenoid reference current to PC solenoid actual current.**
- **Cold transmission fluid-Check for low transmission fluid temperature.**

6. Monitor transmission range on the scan tool, engine list.
 1. Apply the brake pedal and ensure the parking brake is set.
 2. Move the gear selector through all ranges.
 3. Pause 2-3 seconds in each range.
 4. Return gear selector to PARK.
 5. Verify that all selector positions match the scan tool display.
7. Check throttle angle input.
 1. Apply the brake pedal and ensure that the parking brake is set.
 2. Ensure the gear selector is in PARK.
 3. Monitor throttle angle while increasing and decreasing engine speed with the throttle pedal. The scan tool throttle angle should increase and decrease with engine speed.

If any of the above checks do not perform properly, record the result for reference after completion of the road test.

Upshift Control and Torque Converter Clutch (TCC) Apply

The transmission control module (TCM) calculates the upshift points based primarily on 2 inputs: throttle angle and vehicle speed. When the TCM determines that conditions are met for a shift to occur, the TCM commands the shift by closing or opening the ground circuit for the appropriate solenoid.

Perform the following steps:

1. Refer to **Shift Speed** and choose a throttle position shown to cover the normal driving range.
2. Monitor the following scan tool parameters:
 - Throttle angle
 - Vehicle speed
 - Input speed - some models
 - Engine speed
 - Output shaft speed
 - Commanded gear
 - Slip speed
 - Solenoid states
3. Place the gear selector in the OVERDRIVE position.
4. Accelerate the vehicle using the chosen throttle angle. Hold the throttle steady.
5. As the transmission upshifts, note the vehicle speed when the shift occurs for each gear change. There should be a noticeable shift feel or engine speed change within 1-2 seconds of the commanded gear change.
6. Compare the shift speeds to the Shift Speed table. Refer to **Shift Speed** . Shift speeds may vary slightly due to transmission fluid temperature or hydraulic delays in responding to electronic controls.
 - Note any harsh, soft or delayed shifts or slipping.
 - Note any noise or vibration.
7. Repeat steps 1-6 as necessary in order to evaluate the different throttle angles.

IMPORTANT: This transmission is equipped with an electronically controlled capacity clutch (ECCC). The pressure plate does not fully lock to the torque converter cover. Instead, the pressure plate maintains a small amount of slippage, about 20 RPM, in SECOND, THIRD and FOURTH gears, depending on the vehicle application. ECCC was developed to reduce the possibility of noise, vibration or chugge caused by TCC apply. Typical apply speeds are 49-52 km/h (30-32 mph) in THIRD gear and 65-73 km/h (40-45 mph) in FOURTH gear. Full lockup is available at highway speeds on some applications.

IMPORTANT: The TCC will not engage until the engine is in closed loop

operation and the vehicle speed is as shown in the Shift Speed table. Refer to Shift Speed . The vehicle must be in a near-cruise condition, not accelerating or coasting and on a level road surface.

8. Check for TCC apply in THIRD and FOURTH gear.
 - Note the TCC apply point. When the TCC applies there should be a noticeable drop in engine speed and a drop in slip speed to below 100 RPM. If the TCC apply can not be detected:
 - Check for DTCs.
 - Refer to Torque Converter Diagnosis.
 - Refer to the table Shift Speed for the correct apply speed.

Part Throttle Detent Downshift

1. Place the gear selector in the OVERDRIVE position.
2. Accelerate the vehicle to 64-88 km/h (40-55 mph) in FOURTH gear.
3. Quickly increase throttle angle to greater than 50 percent.
4. Verify the following:
 - The TCC releases.
 - The transmission downshifts immediately to THIRD gear.

Full Throttle Detent Downshift

1. Place the gear selector in the OVERDRIVE position.
2. Accelerate the vehicle to speeds of 64-88 km/h (40-55 mph) in FOURTH gear.
3. Quickly increase throttle angle to 100 percent (WOT).
4. Verify the following:
 - The TCC releases.
 - The transmission downshifts immediately to SECOND gear.

Manual Downshifts

The shift solenoid valves do not control the initial downshift for the 4-3 or the 3-2 manual downshifts. The 4-3 and the 3-2 manual downshifts are hydraulic. The 2-1 manual downshift is electronic. The solenoid states should change during or shortly after a manual downshift is selected.

Manual 4-3 Downshift

1. Place the gear selector in the OVERDRIVE position.
2. Accelerate the vehicle to 64-88 km/h (40-55 mph) in FOURTH gear.
3. Release the throttle while moving the gear selector to THIRD.
4. Verify the following:
 - The TCC releases.
 - The transmission downshifts immediately to THIRD gear.
 - The engine slows the vehicle.

Manual 4-2 Downshift

1. Place the gear selector in the OVERDRIVE position.
2. Accelerate the vehicle to 64-72 km/h (40-45 mph).
3. Release the throttle while moving the gear selector to SECOND.
4. Verify the following:
 - The TCC releases.
 - The transmission downshifts immediately to SECOND gear.
 - The engine slows the vehicle.

Manual 4-1 Downshift

1. Place the gear selector in the OVERDRIVE position.
2. Accelerate the vehicle to 48 km/h (30 mph).
3. Release the throttle while moving the gear selector to FIRST.
4. Verify the following:
 - The TCC releases.
 - The transmission downshifts immediately to FIRST gear.
 - The engine slows the vehicle.

Coasting Downshifts

1. Place the gear selector in the OVERDRIVE position.
2. Accelerate the vehicle to FOURTH gear with the TCC applied.
3. Release the throttle and lightly apply the brakes.
4. Verify the TCC releases.

2007 Hummer H3

2007 TRANSMISSION Automatic Transmission - 4L60-E/4L65-E/4L70-E - H3

Manual Gear Range Selection

The shift solenoids control the upshifts in the manual gear ranges.

Perform the following tests using 10-15 percent throttle angle.

Reverse

1. With the vehicle stopped, move the gear selector to REVERSE.
2. Slowly accelerate the vehicle.
3. Verify that there is no noticeable slip, noise or vibration.

Manual First

1. With the vehicle stopped, move the gear selector to FIRST.
2. Accelerate the vehicle to 32 km/h (20 mph).
3. Verify the following:
 - No upshifts occur.
 - The TCC does not apply.
 - There is no noticeable slip, noise or vibration.

Manual Second

1. With the vehicle stopped, move the gear selector to SECOND.
2. Accelerate the vehicle to 57 km/h (35 mph).
3. Verify the following:
 - The 1-2 shift occurs.
 - The 2-3 shift does not occur.
 - There is no noticeable slip, noise or vibration.

Manual Third

1. With the vehicle stopped, move the gear selector to THIRD.
2. Accelerate the vehicle to 64 km/h (40 mph).
3. Verify the following:
 - The 1-2 shift occurs.
 - The 2-3 shift occurs.

- There is no noticeable slip, noise or vibration.

TORQUE CONVERTER DIAGNOSIS

The torque converter clutch (TCC) is applied by fluid pressure, which is controlled by a pulse width modulation (PWM) solenoid valve. This solenoid valve is located inside of the automatic transmission assembly. The solenoid valve is controlled through a combination of computer controlled switches and sensors.

Torque Converter Stator

The torque converter stator roller clutch can have 2 different malfunctions.

- The stator assembly freewheels in both directions.
- The stator assembly remains locked up at all times.

Poor Acceleration at Low Speed

If the stator is freewheeling at all times, the vehicle tends to have poor acceleration from a standstill. At speeds above 50-55 km/h (30-35 mph), the vehicle may act normally. For poor acceleration, you should first determine that the exhaust system is not blocked and the transmission is in First gear when starting out.

If the engine freely accelerates to high RPM in NEUTRAL, you can assume that the engine and the exhaust system are normal. Check for poor performance in DRIVE and REVERSE to help determine if the stator is freewheeling at all times.

Poor Acceleration at High Speed

If the stator is locked up at all times, performance is normal when accelerating from a standstill. Engine RPM and vehicle speed are limited or restricted at high speeds. Visual examination of the converter may reveal a blue color from overheating.

If the converter has been removed, you can check the stator roller clutch by inserting a finger into the splined inner race of the roller clutch and trying to turn the race in both directions. You should be able to freely turn the inner race clockwise, but you should have difficulty in moving the inner race counterclockwise or you may be unable to move the race at all.

Noise

IMPORTANT: Do not confuse this noise with pump whine noise, which is usually noticeable in PARK, NEUTRAL and all other gear ranges.

Pump whine will vary with line pressure.

You may notice a torque converter whine when the vehicle is stopped and the transmission is in DRIVE or REVERSE. This noise will increase as you increase the engine RPM. The noise will stop when the vehicle is moving or when you apply the torque converter clutch, because both halves of the converter are turning at the same speed.

Perform a stall test to make sure the noise is actually coming from the converter:

1. Place your foot on the brake.
2. Put the gear selector in DRIVE.

NOTE: You may damage the transmission if you depress the accelerator for more than 6 seconds.

3. Depress the accelerator to approximately 1,200 RPM for no more than six seconds.

A torque converter noise will increase under this load.

Torque Converter Clutch Shudder

The key to diagnosing TCC shudder is to note when it happens and under what conditions.

TCC shudder which is caused by the transmission should only occur during the apply or the release of the converter clutch. Shudder should never occur after the TCC plate is fully applied.

If Shudder Occurs During TCC Apply or Release

If the shudder occurs while the TCC is applying, the problem can be within the transmission or the torque converter. Something is causing one of the following conditions to occur:

- Something is not allowing the clutch to become fully engaged.
- Something is not allowing the clutch to release.
- The clutch is releasing and applying at the same time.

One of the following conditions may be causing the problem to occur:

- Leaking turbine shaft seals
- A restricted release orifice
- A distorted clutch or housing surface due to long converter bolts

- Defective friction material on the TCC plate

If Shudder Occurs After TCC has Applied

If shudder occurs after the TCC has applied, most of the time there is nothing wrong with the transmission.

The TCC is not likely to slip after the TCC has been applied. Engine problems may go unnoticed under light throttle and load, but they become noticeable after the TCC apply when going up a hill or accelerating. This is due to the mechanical coupling between the engine and the transmission.

Once TCC is applied, there is no torque converter (fluid coupling) assistance. Engine or driveline vibrations could be unnoticeable before TCC engagement.

Inspect the following components in order to avoid misdiagnosis of TCC shudder. An inspection will also avoid the unnecessary disassembly of a transmission or the unnecessary replacement of a torque converter.

- Spark plugs-Inspect for cracks, high resistance or a broken insulator.
- Plug wires-Look in each end. If there is red dust (ozone) or a black substance (carbon) present, then the wires are bad. Also look for a white discoloration of the wire. This indicates arcing during hard acceleration.
- Coil-Look for a black discoloration on the bottom of the coil. This indicates arcing while the engine is misfiring.
- Fuel injector-The filter may be plugged.
- Vacuum leak-The engine will not get a correct amount of fuel. The mixture may run rich or lean depending on where the leak occurs.
- EGR valve-The valve may let in too much or too little unburnable exhaust gas and could cause the engine to run rich or lean.
- MAP/MAF sensor-Like a vacuum leak, the engine will not get the correct amount of fuel for proper engine operation.
- Carbon on the intake valves-Carbon restricts the proper flow of air/fuel mixture into the cylinders.
- Flat cam-Valves do not open enough to let the proper fuel/air mixture into the cylinders.
- Oxygen sensor-This sensor may command the engine too rich or too lean for too long.
- Fuel pressure-This may be too low.
- Engine mounts-Vibration of the mounts can be multiplied by TCC engagement.

- Axle joints-Check for vibration.
- Throttle position (TP) Sensor-The TCC apply and release depends on the TP Sensor in many engines. If the TP Sensor is out of specification, TCC may remain applied during initial engine loading.
- Cylinder balance-Bad piston rings or poorly sealing valves can cause low power in a cylinder.
- Fuel contamination-This causes poor engine performance.

Replace the torque converter if any of the following conditions exist:

- External leaks appear in the hub weld area.
- The converter hub is scored or damaged.
- The converter pilot is broken, damaged or fits poorly into the crankshaft.
- You discover steel particles after flushing the cooler and the cooler lines.
- The pump is damaged or you discover steel particles in the converter.
- The vehicle has TCC shudder and/or no TCC apply. Replace the torque converter only after all hydraulic and electrical diagnoses have been made. The converter clutch material may be glazed.
- The converter has an imbalance which cannot be corrected. Refer to **Flexplate/Torque Converter Vibration Test**.
- The converter fluid is contaminated with engine coolant or water.
- An internal failure occurs in the stator roller clutch.
- You notice excessive end play.
- Overheating produces heavy debris in the clutch or converter ballooning.
- You discover steel particles or clutch lining material in the fluid filter or on the magnet, when no internal parts in the unit are worn or damaged. This condition indicates that lining material came from the converter.

Do not replace the torque converter if you discover any of the following symptoms:

- The oil has an odor or the oil is discolored, even though metal or clutch facing particles are not present.
- The threads in one or more of the converter bolt holds are damaged. Correct the condition with a new thread inset.
- Transmission failure did not display evidence of damaged or worn internal parts, steel particles or clutch plate lining material in the unit and inside the fluid filter.

2007 Hummer H3

2007 TRANSMISSION Automatic Transmission - 4L60-E/4L65-E/4L70-E - H3

- The vehicle has been exposed to high mileage only. An exception may exist where the lining of the torque converter clutch dampener plate has seen excess wear by vehicles operated in heavy and/or constant traffic, such as taxi, delivery or police use.

FLEXPLATE/TORQUE CONVERTER VIBRATION TEST

Isolating Vibration

NOTE: Some engine/transaxle combinations cannot be balanced in this manner due to restricted access or limited clearances between the torque converter bolts and the engine. Ensure that the bolts do not bottom out in the lug nuts or the torque converter cover which could dent and cause internal damage.

To isolate and correct a flywheel or torque converter vibration, separate the torque converter from the flywheel to determine if vibration is in the engine or transmission.

1. With the engine at idle speed and the transmission in PARK or NEUTRAL, observe the vibration.
2. Turn the engine OFF.
3. Raise and suitably support the vehicle. Refer to Lifting and Jacking the Vehicle .
4. Remove the transmission converter cover bolts and the cover.
5. Mark the relationship of the converter to the flywheel.
6. Remove the bolts attaching the converter to the flywheel.
7. Slide the torque converter away from the flywheel.
8. Rotate the flywheel and torque converter to inspect for defects or missing balance weights.
9. Lower the vehicle.
10. With the engine at idle speed and the transmission in PARK or NEUTRAL, observe the vibration. Refer to Diagnostic Starting Point - Vibration Diagnosis and Correction .
11. Turn the engine OFF.

Indexing Torque Converter

To determine and correct a torque converter vibration, the following procedure may have to be performed several times to achieve the best possible torque converter to flywheel balance.

1. Raise and suitably support the vehicle. Refer to Lifting and Jacking the Vehicle .
2. Rotate the torque converter one bolt position.

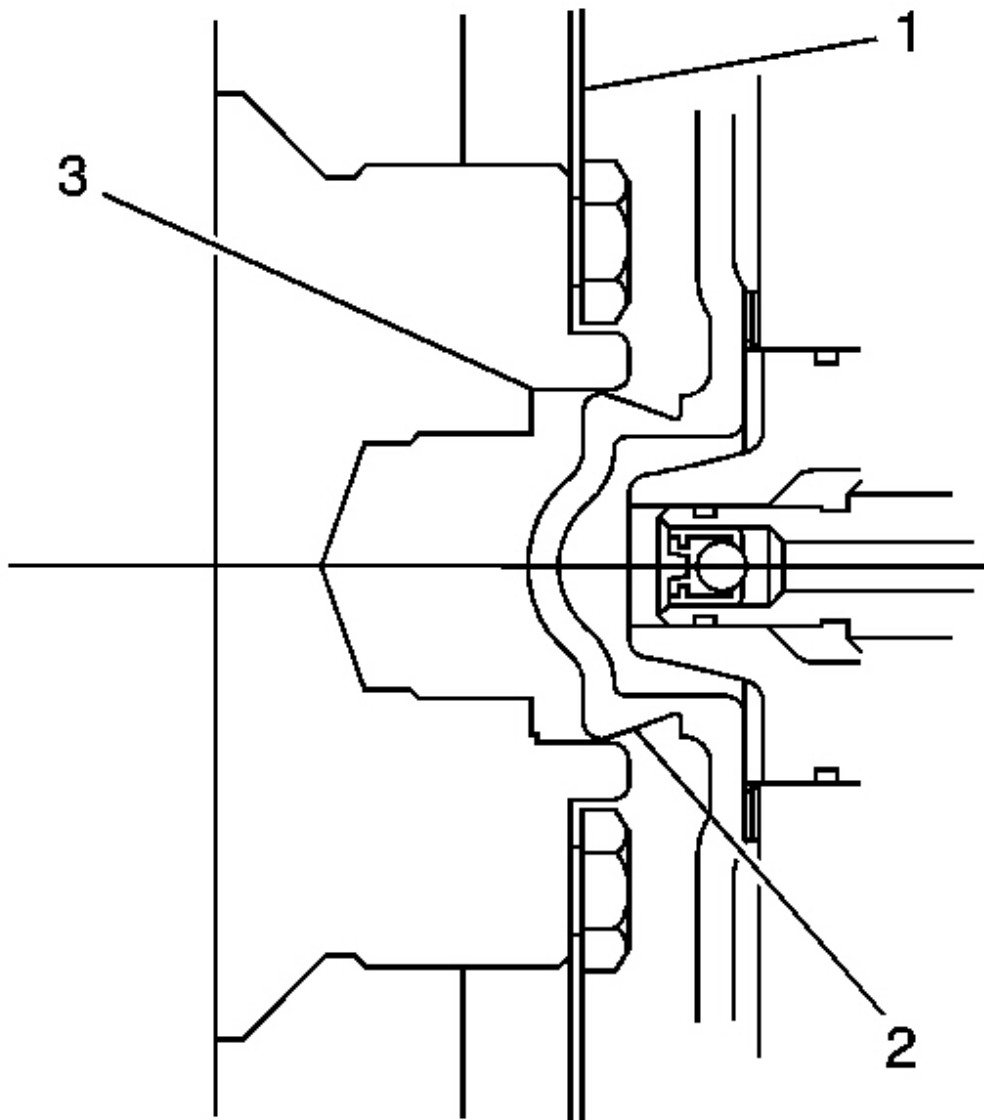

Fig. 3: View Of Torque Converter Hub In Engine Crankshaft
Courtesy of GENERAL MOTORS CORP.

3. Align the torque converter hub (2) in the engine crankshaft (3) and install the torque converter to flywheel bolts.
4. Lower the vehicle.

5. With the engine at idle speed and the transmission in PARK or NEUTRAL, observe the vibration. Refer to **Noise and Vibration Analysis**.

Repeat this procedure until you obtain the best possible balance.

6. Install the transmission converter cover bolts and the cover.

NOISE AND VIBRATION ANALYSIS

A noise or vibration that is noticeable when the vehicle is in motion MAY NOT be the result of the transmission.

If noise or vibration is noticeable in PARK and NEUTRAL with the engine at idle, but is less noticeable as RPM increases, the cause may be from poor engine performance.

- Vibration may also be caused by a small amount of water inside the converter.
- Inspect the tires for the following conditions:
 - Uneven wear
 - Imbalance
 - Mixed sizes
 - Mixed radial and bias ply
- Inspect the suspension components for the following conditions:
 - Alignment wear or damage
 - Loose fasteners
 - Driveline damage or wear
- Inspect the engine and transmission mounts for damage and loose bolts.
- Inspect the transmission case mounting holes for the following conditions:
 - Missing bolts, nuts and studs
 - Stripped threads
 - Cracks
- Inspect the flywheel for the following conditions:
 - Missing or loose bolts
 - Cracks
 - Imbalance
- Inspect the torque converter for the following conditions:
 - Missing or loose bolts or lugs

- Missing or loose balance weights
- Imbalance caused by heat distortion or fluid contamination

CLUTCH PLATE DIAGNOSIS

Composition Plates

Dry the plates and inspect the plates for the following conditions:

- Pitting
- Flaking
- Delamination-splitting or separation of bonded clutch material
- Wear
- Glazing
- Cracking
- Charring
- Chips or metal particles embedded in the lining

Replace a composition plate which shows any of these conditions.

Steel Plates

Wipe the plates dry and check the plates for heat discoloration. If the surfaces are smooth, even if color smear is indicated, you can reuse the plate. If the plate is discolored with heat spots or if the surface is scuffed, replace the plate.

Causes of Burned Clutch Plates

The following conditions can result in a burned clutch plate:

- Incorrect usage of clutch or apply plates
- Engine coolant or water in the transmission fluid
- A cracked clutch piston
- Damaged or missing seals
- Low line pressure
- Valve body conditions
 - The valve body face is not flat.
 - Porosity is between channels.

- The valve bushing clips are improperly installed.
- The checkballs are misplaced.
- The Teflon® seal rings are worn or damaged.

ENGINE COOLANT/WATER IN TRANSMISSION

NOTE: **The antifreeze or water will deteriorate the seals, gaskets and the glue that bonds the clutch material to the pressure plate. Both conditions may cause damage to the transmission.**

If antifreeze or water has entered the transmission, perform the following:

1. Disassemble the transmission.
2. Replace all of the rubber type seals (the coolant will attack the seal material which will cause leakage).
3. Replace the composition-faced clutch plate assemblies and the 2-4 band assembly (the facing material may separate from the steel center portion).
4. Replace all of the nylon parts (washers).
5. Replace the torque converter.
6. Thoroughly clean and rebuild the transmission, using new gaskets (bonded and non bonded) and oil filter.
7. Flush the cooler lines after the transmission cooler has been properly repaired or replaced.

FLUID LEAK DIAGNOSIS

General Method

1. Verify that the leak is transmission fluid.
2. Thoroughly clean the suspected leak area.
3. Operate the vehicle for 24 km (15 mi) or until normal operating temperatures are reached.
4. Park the vehicle over clean paper or cardboard.
5. Shut OFF the engine.
6. Look for fluid spots on the paper.
7. Make the necessary repairs.

Powder Method

1. Thoroughly clean the suspected leak area with solvent.

2. Apply an aerosol type powder, such as foot powder, to the suspected leak area.
3. Operate the vehicle for 24 km (15 mi) or until normal operating temperatures are reached.
4. Shut OFF the engine.
5. Inspect the suspected leak area.
6. Trace the leak path through the powder in order to find the source of the leak.
7. Make the necessary repairs.

Dye and Black Light Method

A fluid dye and black light kit is available from various tool manufacturers.

1. Follow the manufacturer's instructions in order to determine the amount of dye to use.
2. Detect the leak with the black light.
3. Make the necessary repairs.

Find the Cause of the Leak

Pinpoint the leak and trace the leak back to the source. You must determine the cause of the leak in order to repair the leak properly. For example, if you replace a gasket, but the sealing flange is bent, the new gasket will not repair the leak. You must also repair the bent flange. Before you attempt to repair a leak, check for the following conditions and make repairs as necessary:

Gaskets

- Fluid level/pressure is too high
- Plugged vent or drain-back holes
- Improperly tightened fasteners
- Dirty or damaged threads
- Warped flanges or sealing surface
- Scratches, burrs or other damage to the sealing surface
- Damaged or worn gasket
- Cracking or porosity of the component
- Improper sealant used, where applicable
- Incorrect gasket

Seals

- Fluid level/pressure is too high

- Plugged vent or drain-back holes
- Damaged seal bore
- Damaged or worn seal
- Improper installation
- Cracks in component
- Manual or output shaft surface is scratched, nicked or damaged
- Loose or worn bearing causing excess seal wear

Possible Points of Fluid Leaks

Transmission Oil Pan

- Incorrectly tightened oil pan bolts
- Improperly installed or damaged oil pan gasket
- Damaged oil pan or mounting face
- Incorrect oil pan gasket

Case Leak

- Damaged or missing fill tube seal
- Mislocated fill tube bracket
- Damaged vehicle speed sensor seal
- Damaged manual shaft seal
- Loose or damaged oil cooler connector fittings
- Worn or damaged propeller shaft oil seal
- Loose line pressure pipe plug
- Warped
- Distorted torque converter housing
- Porous casting

Leak at the Torque Converter End

- Converter leak in the weld area
- Converter seal lip cut. Check the converter hub for damage
- Converter seal bushing moved forward and damaged
- Converter seal garter spring missing from the seal

2007 Hummer H3

2007 TRANSMISSION Automatic Transmission - 4L60-E/4L65-E/4L70-E - H3

- Porous casting of the transmission case or the oil pump

Leak at the Vent Pipe or the Fluid Fill Tube

- Overfilled system
- Water or coolant in the fluid-the fluid will appear milky.
- Transmission case porous
- Incorrect fluid level indicator
- Plugged vent
- Drain-back holes plugged
- Mispositioned oil pump to case gasket, if equipped

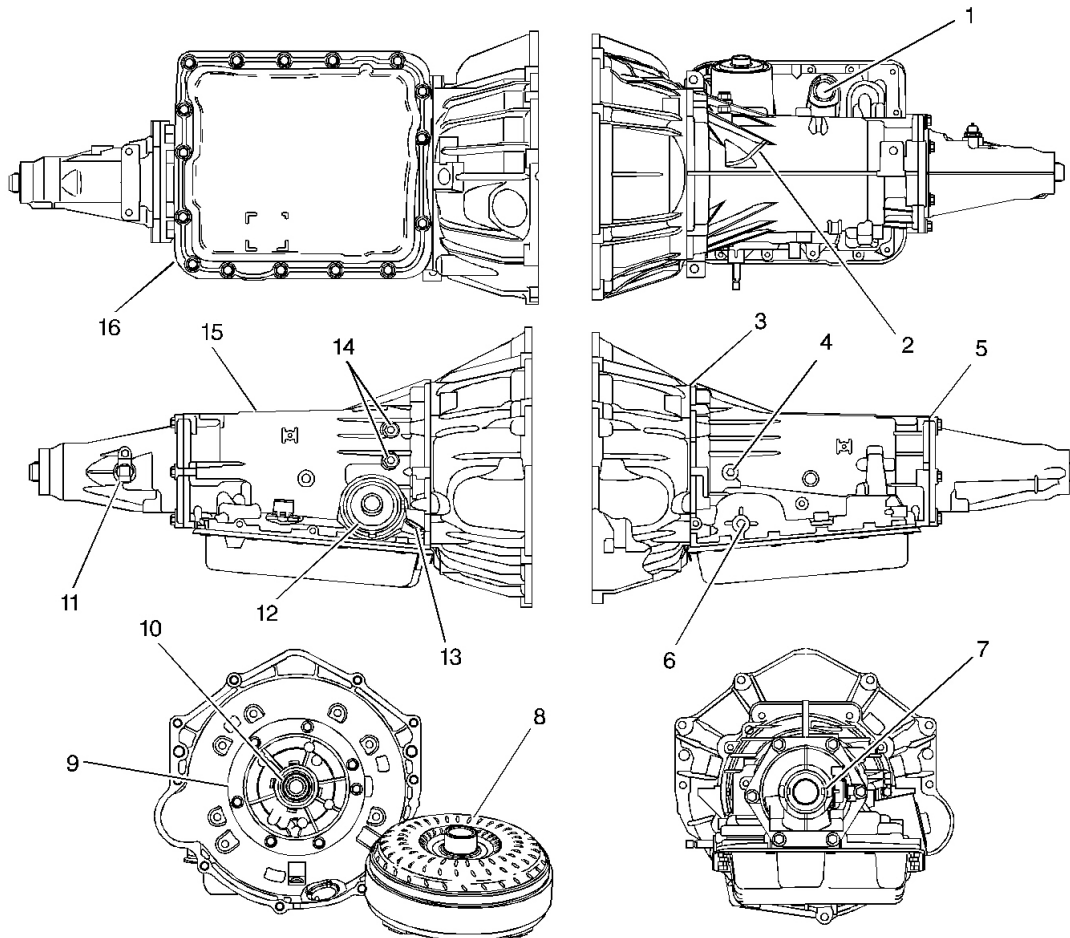

Fig. 4: Identifying Leak Inspection Points
Courtesy of GENERAL MOTORS CORP.

2007 Hummer H3

2007 TRANSMISSION Automatic Transmission - 4L60-E/4L65-E/4L70-E - H3

Callouts For Fig. 4

Callout	Component Name
1	Wiring Harness Pass-Through Connector O-ring Seal
2	Transmission Vent Assembly
3	Converter Housing to Case Joint (Pump to Case Oil Seal)
4	Line Pressure Plug
5	Case Extension to Case Seal
6	Manual Shaft Seal
7	Case Extension Oil Seal Assembly
8	Torque Converter Assembly
9	Pump to Case Oil Seal
10	Pump Oil Seal Assembly
11	Internal Transmission Speed Sensor to Case O-ring Seal - Some Models
12	2-4 Servo Cover O-ring Seal
13	Oil Fill Tube Seal
14	Oil Cooler Pipe Connectors
15	Transmission Case
16	Transmission Oil Pan Gasket

CASE POROSITY REPAIR

Some external leaks are caused by case porosity in non-pressurized areas. You can usually repair these leaks with the transmission in the vehicle.

1. Thoroughly clean the area to be repaired with a cleaning solvent. Air dry the area.

CAUTION: Epoxy adhesive may cause skin irritations and eye damage. Read and follow all information on the container label as provided by the manufacturer.

2. Using instructions from the manufacturer, mix a sufficient amount of an epoxy to make the repair.
3. While the transmission case is still hot, apply the epoxy. You can use a clean, dry soldering acid brush to clean the area and also to apply the epoxy cement. Make certain that the area to be repaired is fully covered.
4. Allow the epoxy cement to cure for three hours before starting the engine.
5. Repeat the fluid leak diagnosis procedures.

SHIFT SOLENOID LEAK TEST

Tools Required

- **J 35616** GM Terminal Test Kit
- **J 44246** Solenoid Testing Kit. See **Special Tools**.

Leak Test Procedure

- IMPORTANT:**
- This procedure tests On/Off type solenoid valves.
 - Visually inspect the physical condition of the solenoid before testing. Inspect the O-rings before and after the test to be sure that they are not cut or damaged.

1. Remove the shift solenoid valve from the control valve body or the torque converter clutch (TCC) solenoid valve from the transmission case. Refer to **Control and Shift Solenoids Replacement** or **Torque Converter Clutch Pulse Width Modulation Solenoid, Torque Converter Clutch Solenoid and Wiring Harness**.

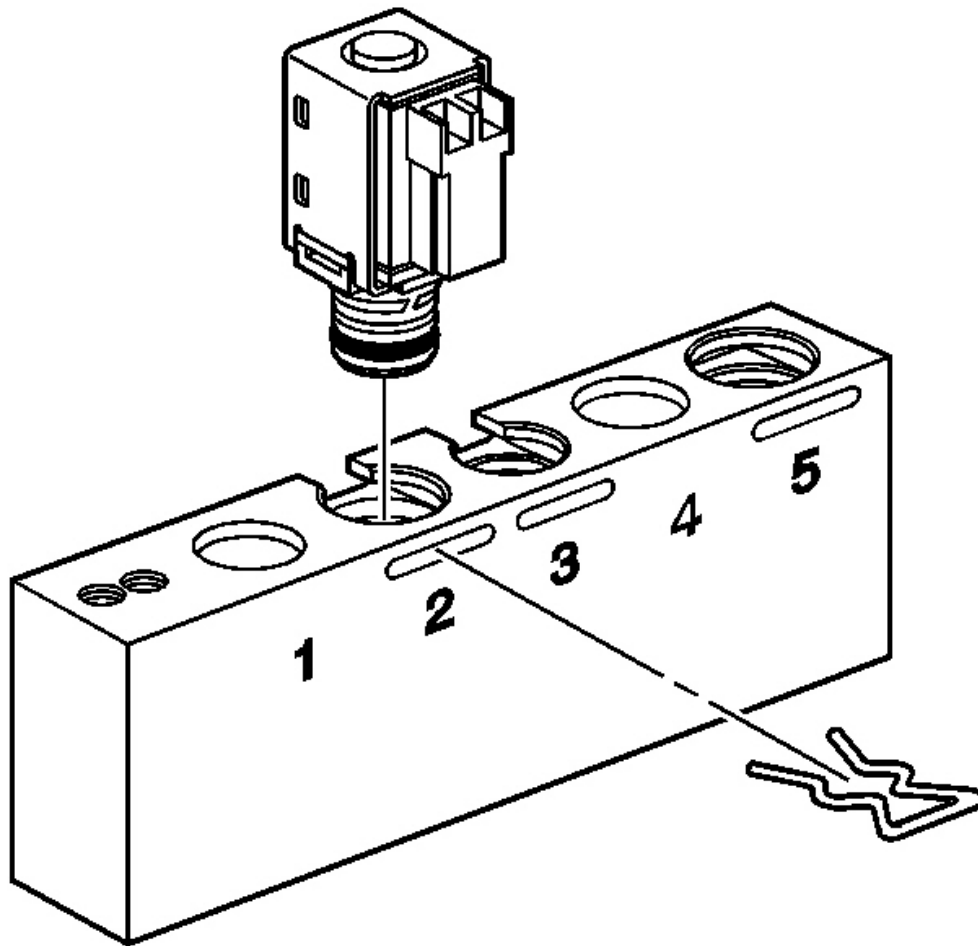

Fig. 5: Installing Valve Into J 44246
Courtesy of GENERAL MOTORS CORP.

2. Install the TCC solenoid valve, the 1-2 shift solenoid valve or the 2-3 shift solenoid valve into bore number 2 of the **J 44246** and install the factory retainer clip to retain the solenoid. See **Special Tools**.

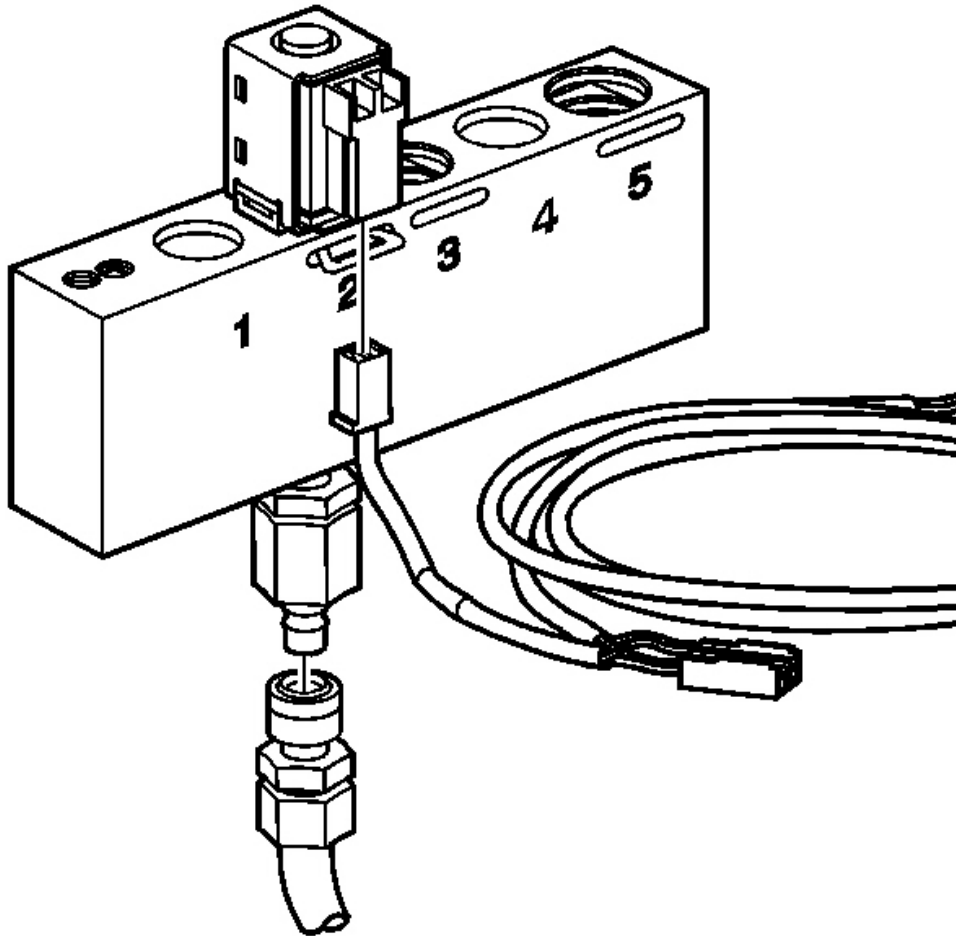

Fig. 6: Connecting Solenoid Testing Harness To Solenoid
Courtesy of GENERAL MOTORS CORP.

IMPORTANT: The supplied solenoid testing harness will not power the 4L60-E TCC On/Off solenoid. To energize this solenoid, apply battery, 12-volt, positive (+) and negative (-) to the TCC On/Off solenoid wiring harness using connector test adapter kit J 35616 . Use terminal E, Red, Power and terminal T, Black, Ground. Refer to the Automatic Transmission Inline 20-Way Connector End View .

3. Connect the solenoid testing harness supplied with the **J 44246** to the solenoid. See **Special Tools**.

IMPORTANT: Do not use air pressure in excess of 827.4 kPa (120 psi). Excessive pressure will not allow the solenoid ball check valve to seat properly. Recommended air pressure is 344.75 kPa (50 psi).

4. Apply compressed air to the **J 44246** . See **Special Tools**.
5. Air should flow through the solenoid. If air does not flow through the solenoid, replace the solenoid. Refer to **Control and Shift Solenoids Replacement**.
6. Connect the solenoid testing harness to the 12-volt positive (+) and negative (-) battery terminals.
7. Observe if the solenoid is operating electrically. An audible clicking noise can be heard when connecting or disconnecting power.

IMPORTANT:

- All solenoids need to be energized to seal.
- A small amount of air leakage is normal +/- 21 kPa (+/- 3 psi).

8. Observe the air flow through the solenoid. The flow will completely or nearly completely stop. Replace the solenoid if there continues to be an obvious air leak when the solenoid is energized.

IMPORTANT: Inspect the O-rings after the test to be sure that they are not cut or damaged.

9. Install the shift solenoid valve into the control valve body or the TCC solenoid valve into the transmission case. Refer to **Control and Shift Solenoids Replacement** or **Torque Converter Clutch Pulse Width Modulation Solenoid, Torque Converter Clutch Solenoid and Wiring Harness**.

TRANSMISSION FLUID COOLER FLUSHING AND FLOW TEST (J 45096)

GM studies indicate that plugged or restricted transmission oil coolers and pipes cause insufficient transmission lubrication and elevated operating temperatures which can lead to premature transmission failure. Many repeat repair cases could have been prevented by following published procedures for transmission oil cooler flushing and flow checking. This procedure

2007 Hummer H3

2007 TRANSMISSION Automatic Transmission - 4L60-E/4L65-E/4L70-E - H3

includes flow checking and flushing the auxiliary transmission oil cooler, if equipped.

IMPORTANT: Use the J 45096 or equivalent to flush and flow test the transmission oil cooler and the oil cooler pipes after the transaxle is removed for repairs. See Special Tools.

Only GM Goodwrench DEXRON®VI automatic transmission fluid should be used when doing a repair on a GM transmission.

Time allowance for performing the cooler flow checking and flushing procedure has been included in the appropriate labor time guide operations since the 1987 model year. The service procedure steps for oil cooler flushing and flow testing are as follows:

Cooler Flow Check and Flushing Steps

1. Machine Set-up
2. Determine Minimum Flow Rate
3. Back Flush
4. Forward Flush
5. Flow Test
6. Code Recording Procedure
7. Clean-up

Tools Required

- **J 35944-200** Cooler Flushing Adapter. See Special Tools.
- **J 45096** Transmission Oil Cooling System Flush and Flow Test Tool. See Special Tools.
- Shop air supply with water/oil filters, regulator and pressure gage-minimum 90 psi
- Eye protection
- Rubber gloves

Machine Set-up

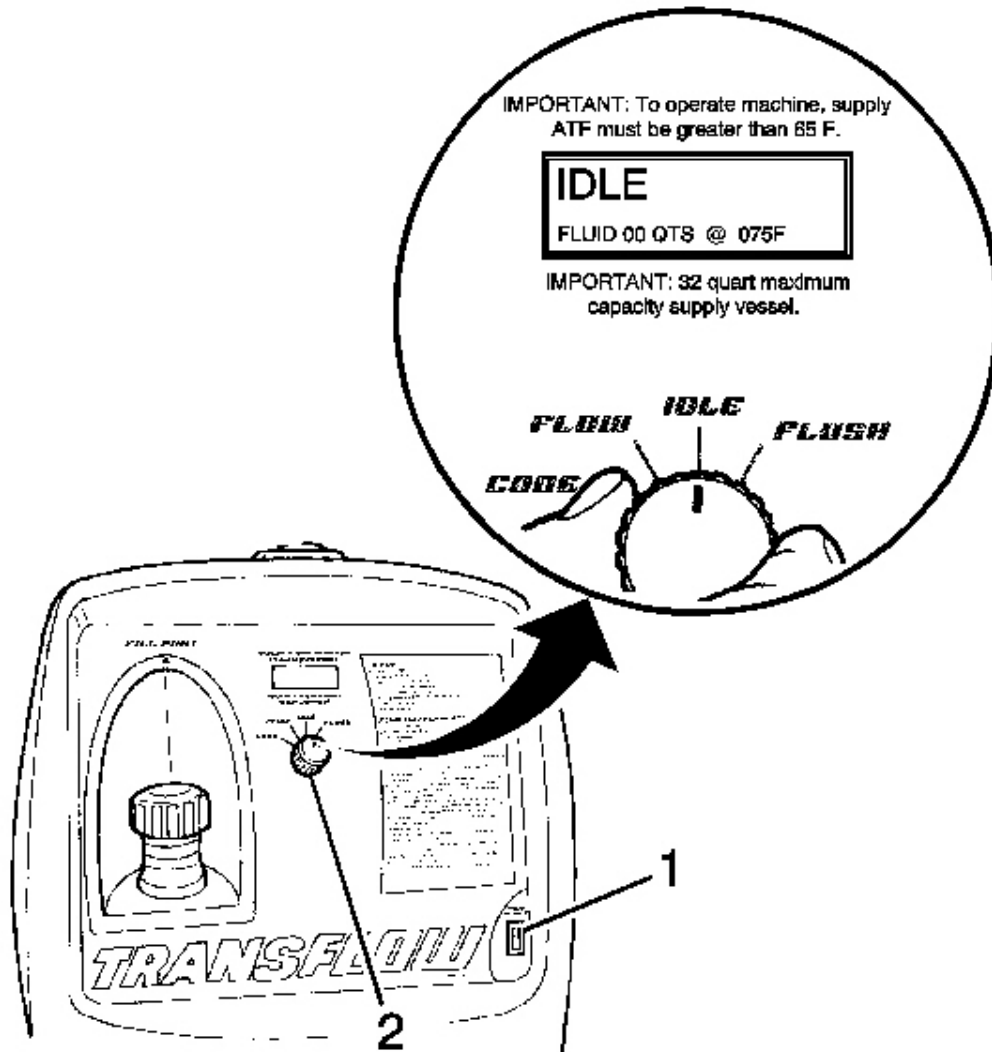

Fig. 7: View Of Main Power Switch & Main Function Switch
Courtesy of GENERAL MOTORS CORP.

1. Verify that the main power switch (1) is in the OFF position.
2. Place the main function switch (2) in the IDLE position.

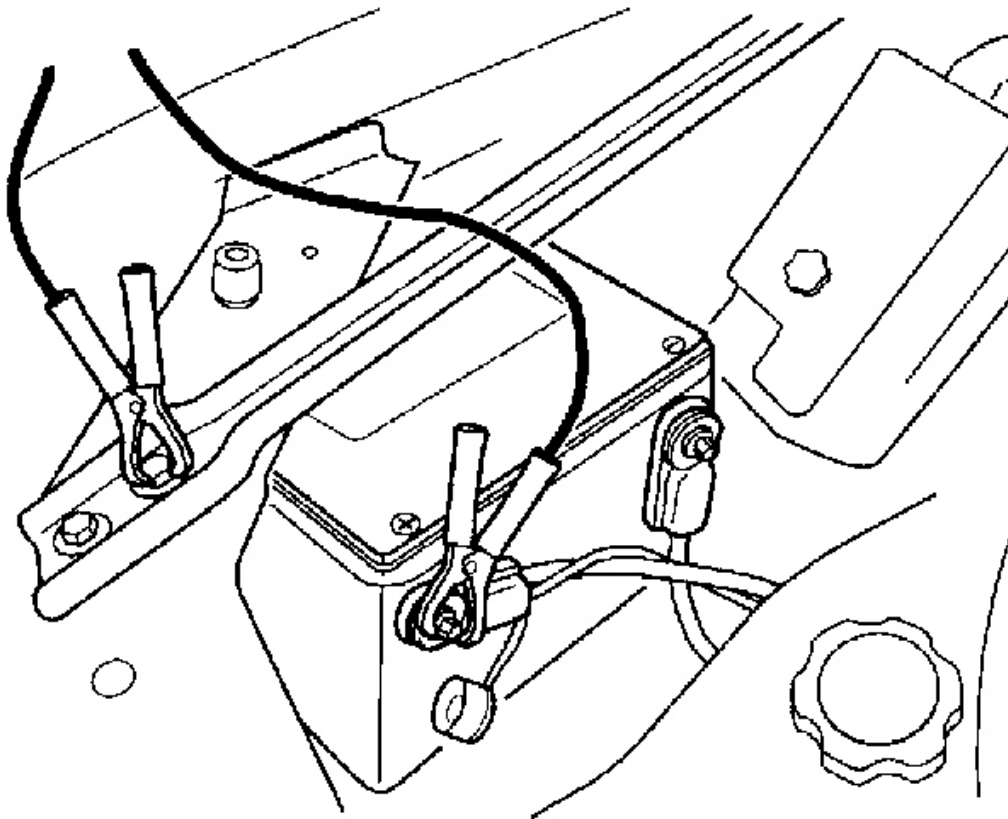

Fig. 8: Connecting To 12V DC Power Source
Courtesy of GENERAL MOTORS CORP.

3. Connect **J 45096** to the vehicle 12-volt DC power source by connecting the red battery clip to the positive (+) battery post on the vehicle and connect the negative (-) lead to a known good chassis ground. See **Special Tools**.
4. Turn the main power switch to the ON position.

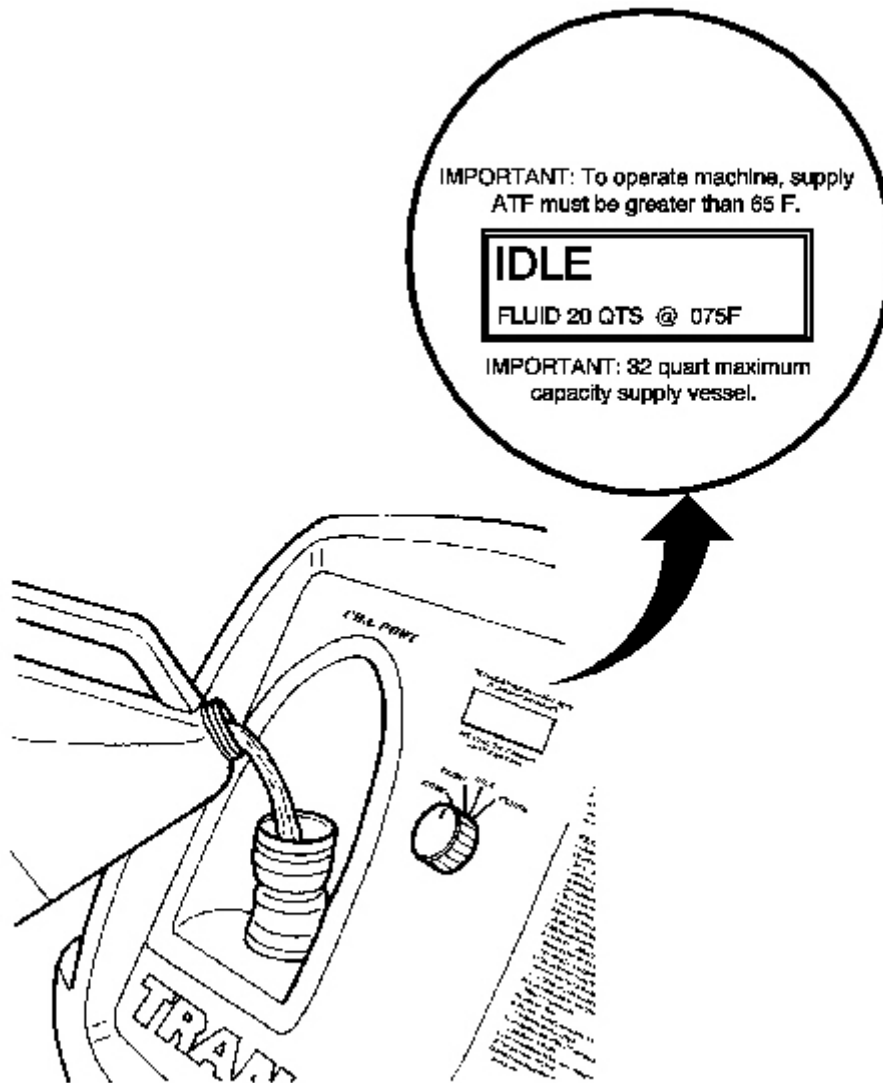

Fig. 9: Filling Supply Tank With Transmission Fluid
Courtesy of GENERAL MOTORS CORP.

NOTE: Do not overfill the supply vessel. Damage to the unit may result. To verify the fluid level, view the LCD screen display while filling the unit, to ensure the fluid level does not exceed 30 L (32 qt).

5. Fill the supply tank with Dexron®VI or equivalent, through the fill port.
6. Install and tighten the fill cap.

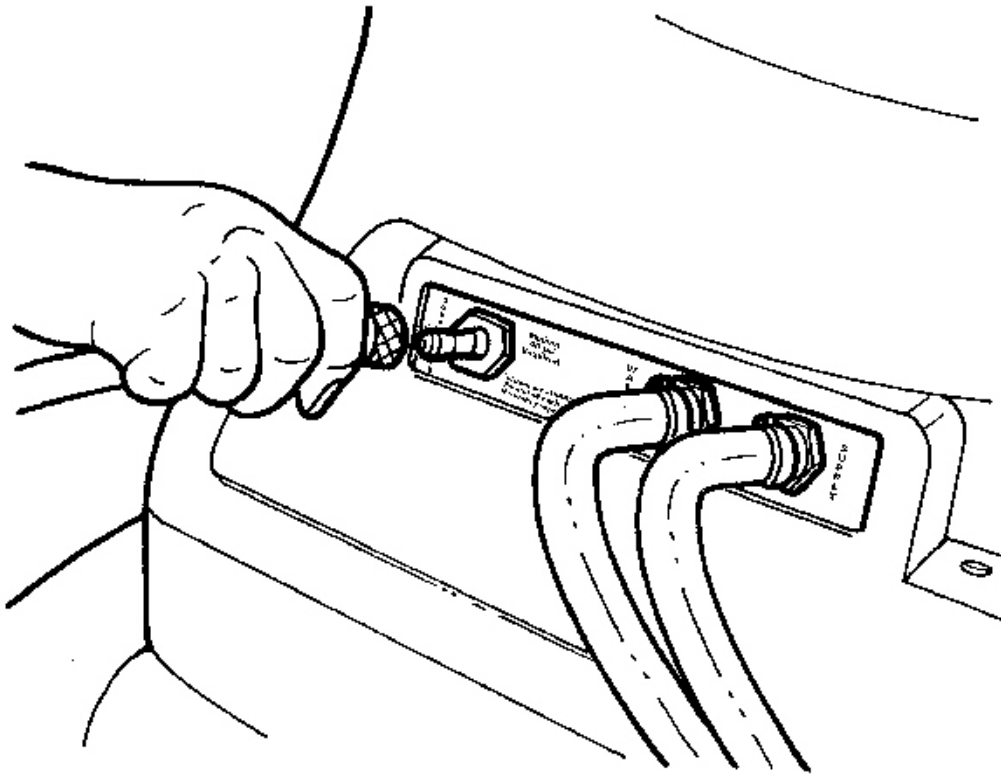

Fig. 10: Applying Shop Air Supply Hose To Quick-Disconnect
Courtesy of GENERAL MOTORS CORP.

7. Connect a shop air supply hose to the quick-disconnect on the rear panel marked SUPPLY AIR.

Determine Minimum Flow Rate

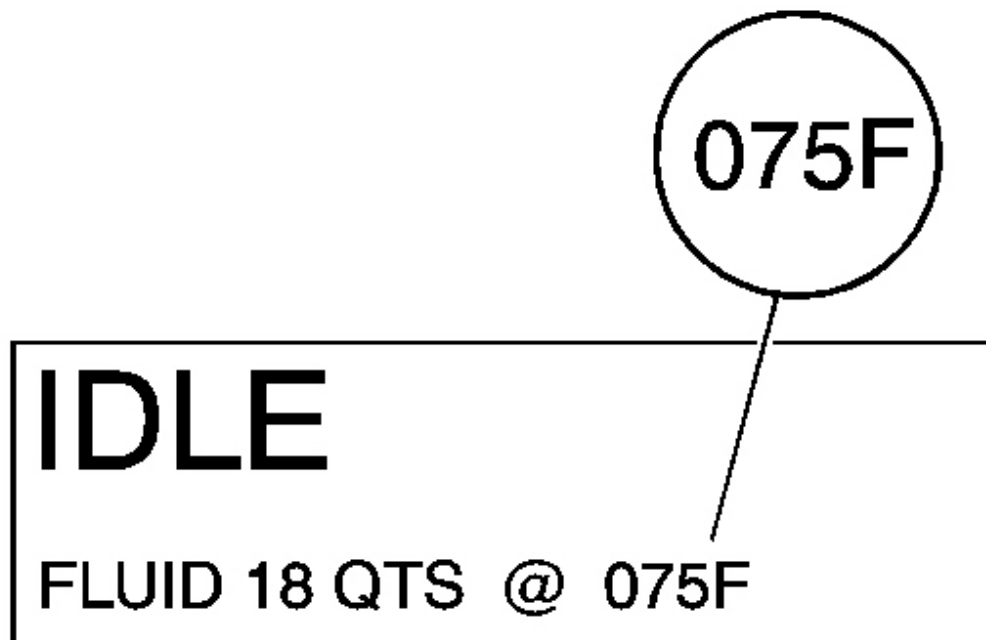

Fig. 11: Identifying Machine Display Of Automatic Transmission Fluid Temperature

Courtesy of GENERAL MOTORS CORP.

1. From the machine display, identify the temperature of the automatic transmission fluid that is stored in the supply vessel of **J 45096** . See **Special Tools**.

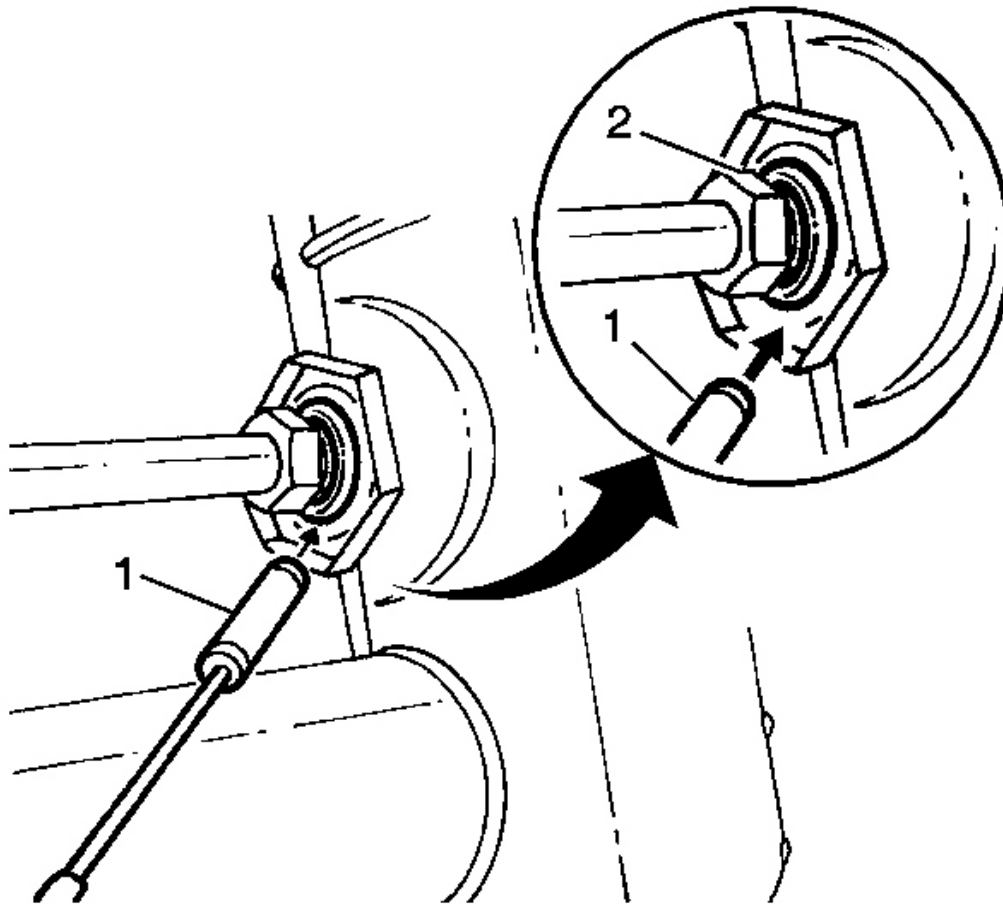

Fig. 12: Identifying Transmission Oil Cooler Metal Composition
Courtesy of GENERAL MOTORS CORP.

2. Determine whether the transmission oil cooler is steel or aluminum by using a magnet (1) at the cooler flange (2) at the radiator.
3. Refer to the table below. Using the temperature from step 1, locate on either the Steel MINIMUM Flow Rate table or the Aluminum MINIMUM Flow Rate table the minimum flow rate in gallons per minutes (GPM). Record the minimum flow rate in GPMs and the supply fluid temperature for further reference.

Example:

- Fluid temperature: 24°C (75°F)

2007 Hummer H3

2007 TRANSMISSION Automatic Transmission - 4L60-E/4L65-E/4L70-E - H3

- Cooler type: Steel

The MINIMUM flow rate for this example would be 0.8 GPM.

4. Inspect transmission oil cooler lines for damage or kinks that could cause restricted oil flow. Repair as needed and refer to the appropriate GM service manual procedures.

Minimum Flow Rate in Gallons Per Minute (GPM)

Temperature Range	Steel	Aluminum
65-66°F	0.6 gpm	0.5 gpm
67-70°F	0.7 gpm	0.6 gpm
71-75°F	0.8 gpm	0.7 gpm
76-80°F	0.9 gpm	0.8 gpm
81-84°F	1.0 gpm	0.9 gpm
85-89°F	1.1 gpm	1.0 gpm
90-94°F	1.2 gpm	1.1 gpm
95-98°F	1.3 gpm	1.2 gpm
99-103°F	1.4 gpm	1.3 gpm
104-108°F	1.5 gpm	1.4 gpm
109-112°F	1.6 gpm	1.5 gpm
113-117°F	1.7 gpm	1.6 gpm
118-120°F	1.8 gpm	1.7 gpm

Back Flush Procedure

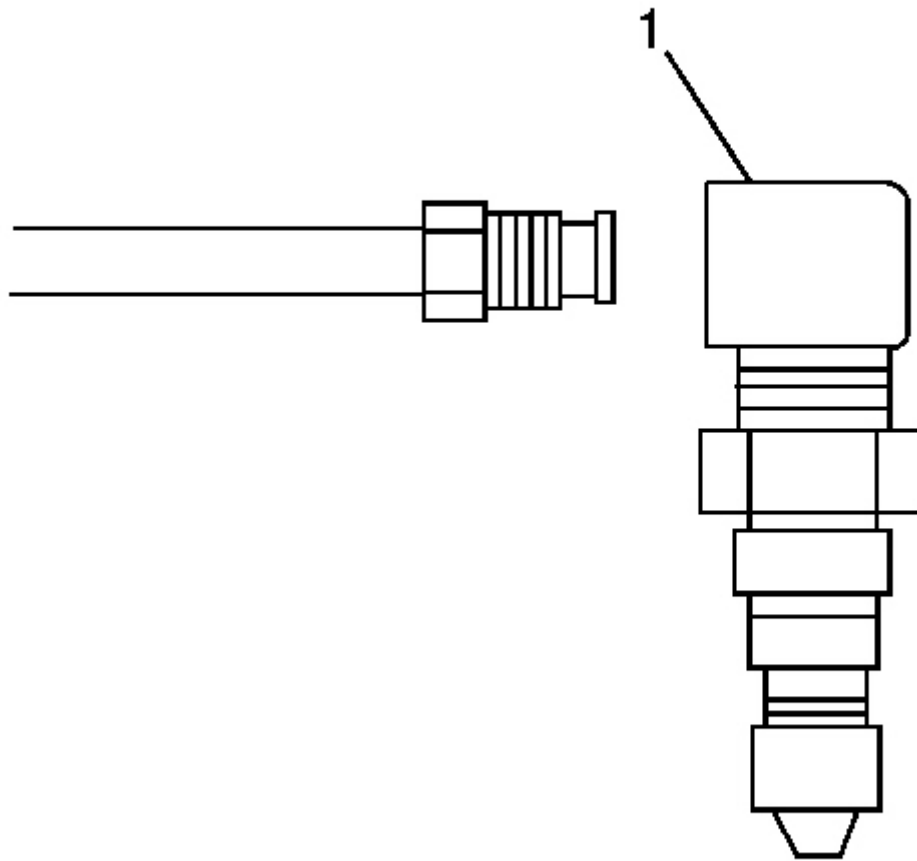

Fig. 13: Connecting J 45096 Adapters To Oil Cooler Supply And Return Lines
Courtesy of GENERAL MOTORS CORP.

1. Connect the **J 45096** adapters (1) to the vehicle transmission oil cooler supply and return lines at the transmission, may require **J 35944-200** . See **Special Tools**.

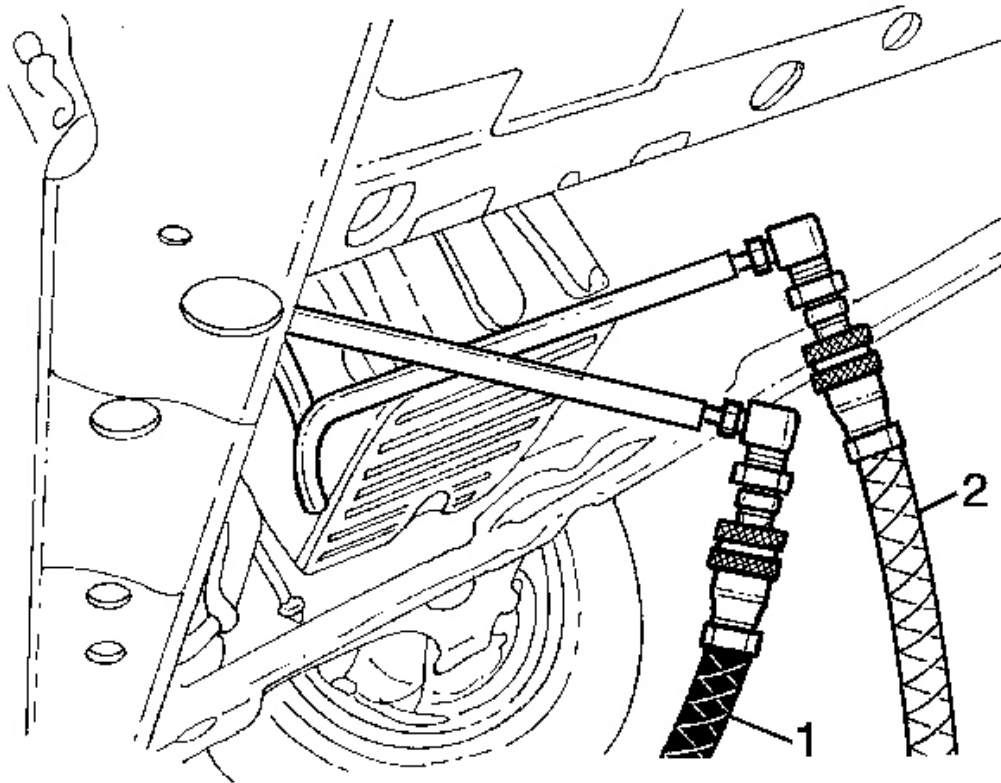

Fig. 14: Identifying Black Supply Hose And Clear Waste Hose
Courtesy of GENERAL MOTORS CORP.

2. Connect the black supply hose (1) to the return line, top connector of the transmission and the clear waste hose (2) to the feed line, bottom connector of the transmission, to the vehicle cooler lines. This is the reverse flow backflush direction.

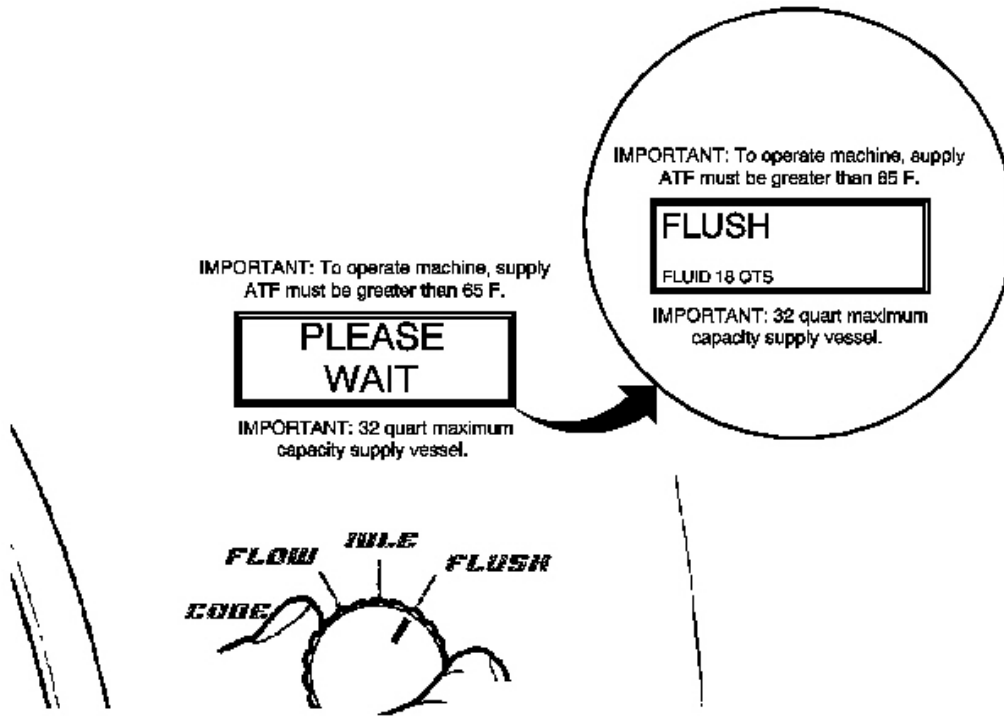

Fig. 15: Setting Main Function Switch To FLUSH Position
Courtesy of GENERAL MOTORS CORP.

3. Turn the main function switch to the FLUSH position. Allow the machine to operate for 30 seconds.

IMPORTANT: To operate machine, supply
ATF must be greater than 65 F.

IDLE

FLUID 16 QTS @ 075F

IMPORTANT: 32 quart maximum
capacity supply vessel.



Fig. 16: Setting Main Function Switch To IDLE Position
Courtesy of GENERAL MOTORS CORP.

4. Turn the main function switch to the IDLE position and allow the supply vessel pressure to dissipate.

Forward Flush

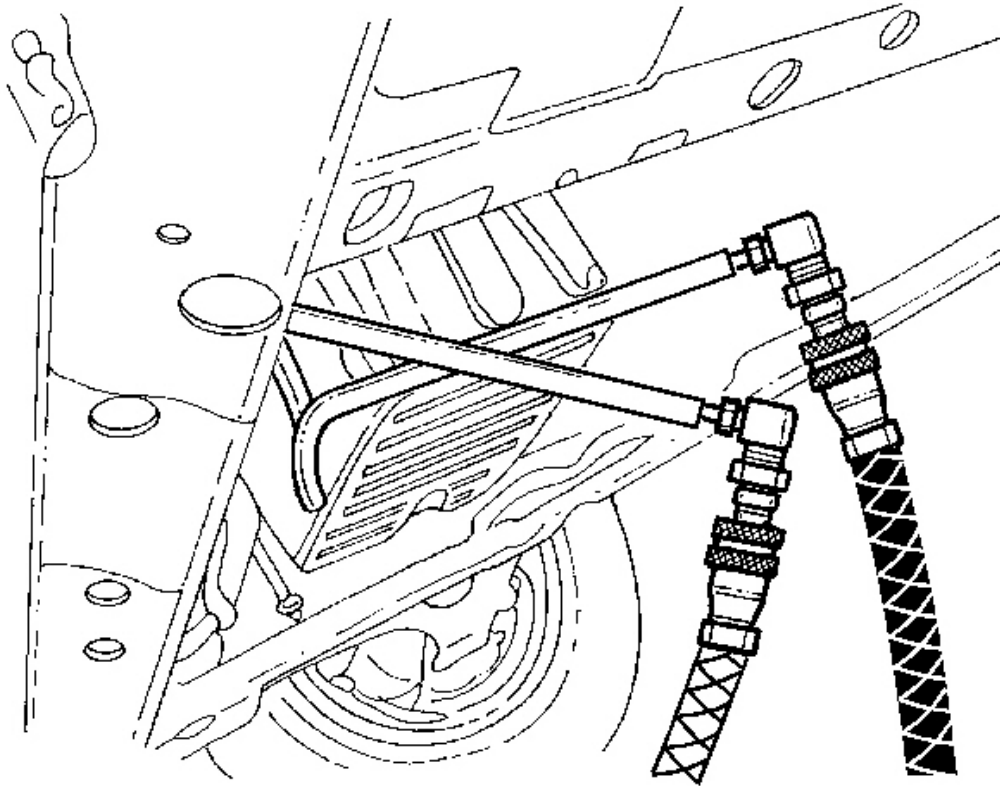

Fig. 17: Identifying Black Supply Hose And Clear Waste Hose
Courtesy of GENERAL MOTORS CORP.

1. Disconnect the supply and waste hoses from the vehicle cooler lines. Reverse the supply and waste hoses to provide a normal flow direction.

IMPORTANT: To operate machine, supply
ATF must be greater than 65 F.

FLUSH

FLUID 18 QTS

IMPORTANT: 32 quart maximum
capacity supply vessel.



Fig. 18: Setting Main Function Switch To FLUSH Position
Courtesy of GENERAL MOTORS CORP.

2. Turn the main function switch to the FLUSH position and allow the machine to operate for 30 seconds.

Flow Test

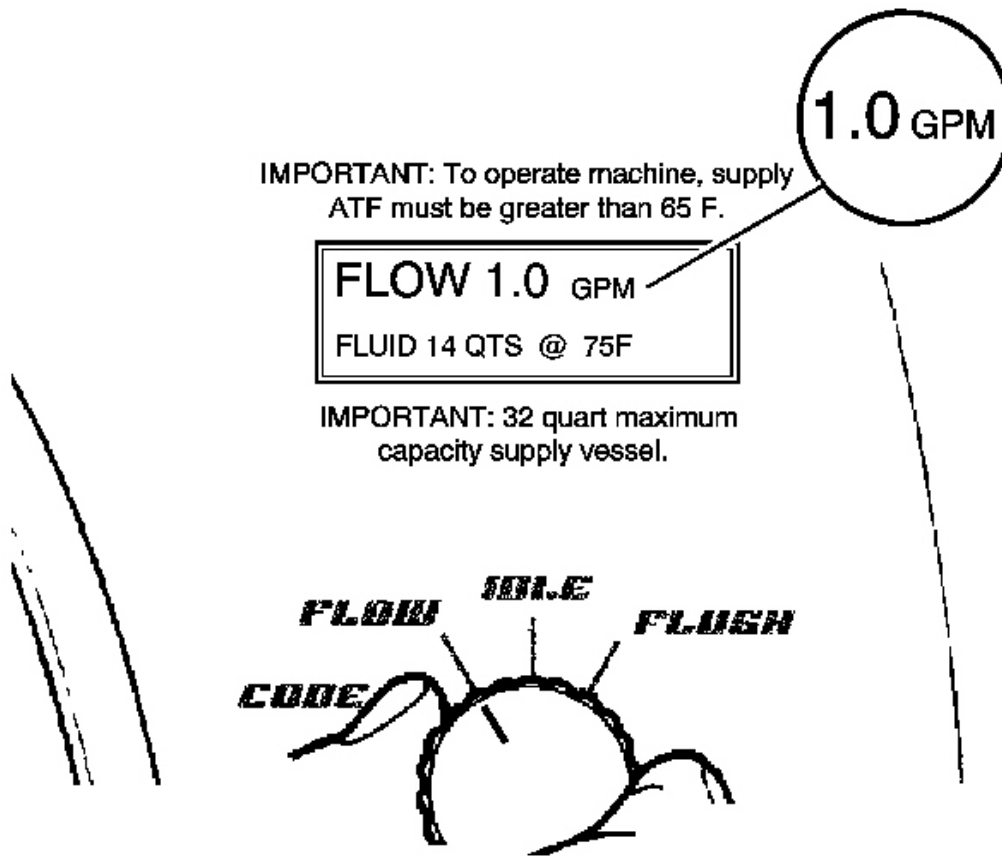

Fig. 19: Setting Main Function Switch To FLOW Position
 Courtesy of GENERAL MOTORS CORP.

IMPORTANT: If the flow rate is less than 0.5 gpm, the LCD displays an error message. Refer to the appropriate troubleshooting section of the operation manual.

1. Turn the main function switch to the FLOW position and allow the oil to flow for 15 seconds. Observe and note the flow rate. This is the TESTED flow rate.
2. Compare the TESTED flow rate to the MINIMUM flow rate information previously recorded.
 - If the TESTED flow rate is equal to or greater than the MINIMUM flow rate recorded, the oil cooling system is functioning properly. Perform Code Recording

Procedure.

- If the TESTED flow rate is less than the MINIMUM flow rate previously recorded, repeat the back flush and forward flush procedures.
3. If the TESTED flow rate is less than the MINIMUM flow rate after the second test, perform the Code Recording Procedure.
 1. Replace the transmission oil cooler.
 2. Connect the supply and waste hoses to the cooler lines in the normal flow direction. Perform the Flow Test.
 3. Perform the Code Recording Procedure.

Code Recording Procedure

IMPORTANT: To operate machine, supply ATF must be greater than 65 F.

FLOW 1.0 @ 75F CYCLE 6
A10DFB2

IMPORTANT: 32 quart maximum capacity supply vessel.



Fig. 20: Setting Main Function Switch To CODE Position
Courtesy of GENERAL MOTORS CORP.

1. Turn the main function switch to the CODE position.

2007 Hummer H3

2007 TRANSMISSION Automatic Transmission - 4L60-E/4L65-E/4L70-E - H3

IMPORTANT:

- **If power is interrupted prior to the recording of the 7-character code, the code will be lost and the flow rate test will need to be repeated.**
 - **The flow test must run for a minimum of 8-10 seconds and be above 0.5 gpm for a code to be generated.**
2. Record TESTED flow rate, temperature, cycle and seven-character flow code information on the repair order.

Clean-Up

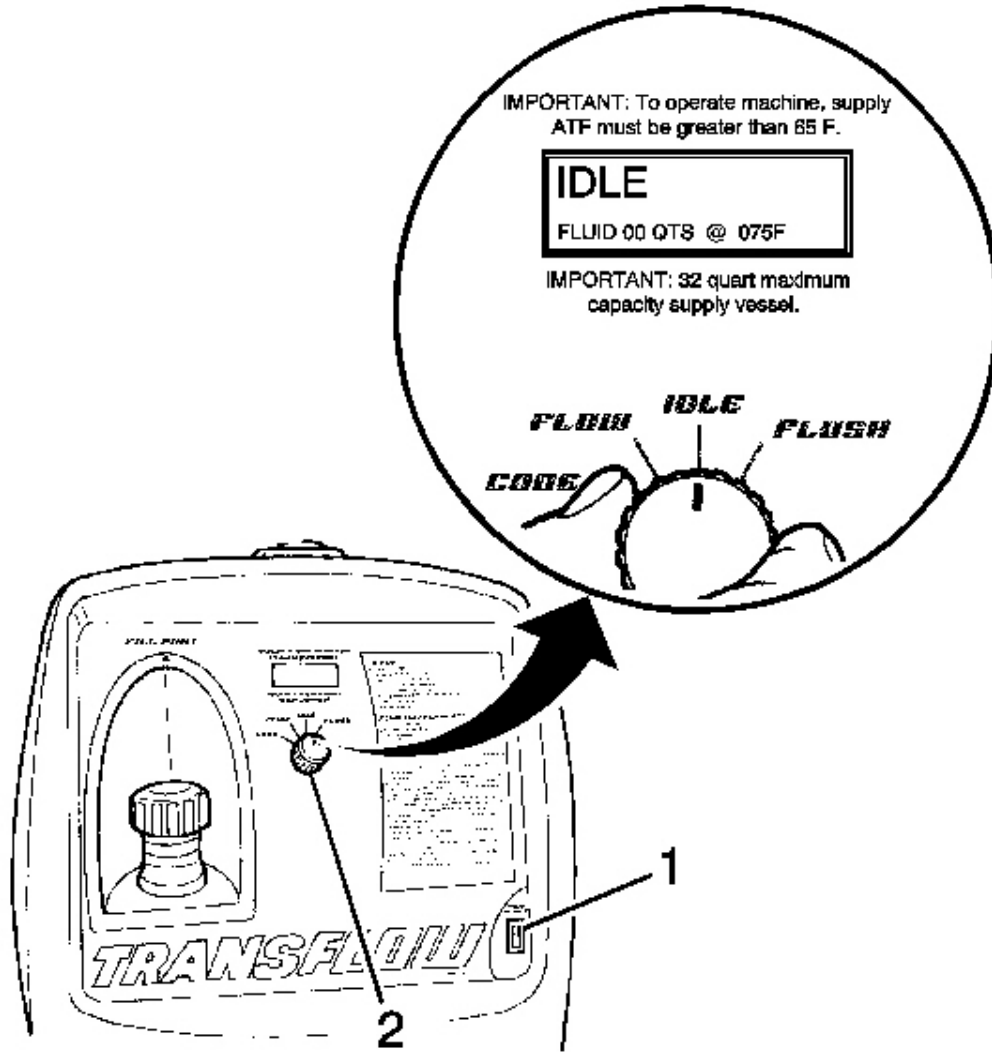

Fig. 21: View Of Main Power Switch & Main Function Switch
Courtesy of GENERAL MOTORS CORP.

1. Turn the main function switch to the IDLE position and allow the supply vessel pressure to dissipate.
2. Turn the main power switch to the OFF position.

IMPORTANT: A small amount of water may drain from the bottom of the

unit when the air supply is disconnected. This is a normal operation of the built-in water separator.

3. Disconnect the supply and waste hoses and the 12-volt power source from the vehicle.

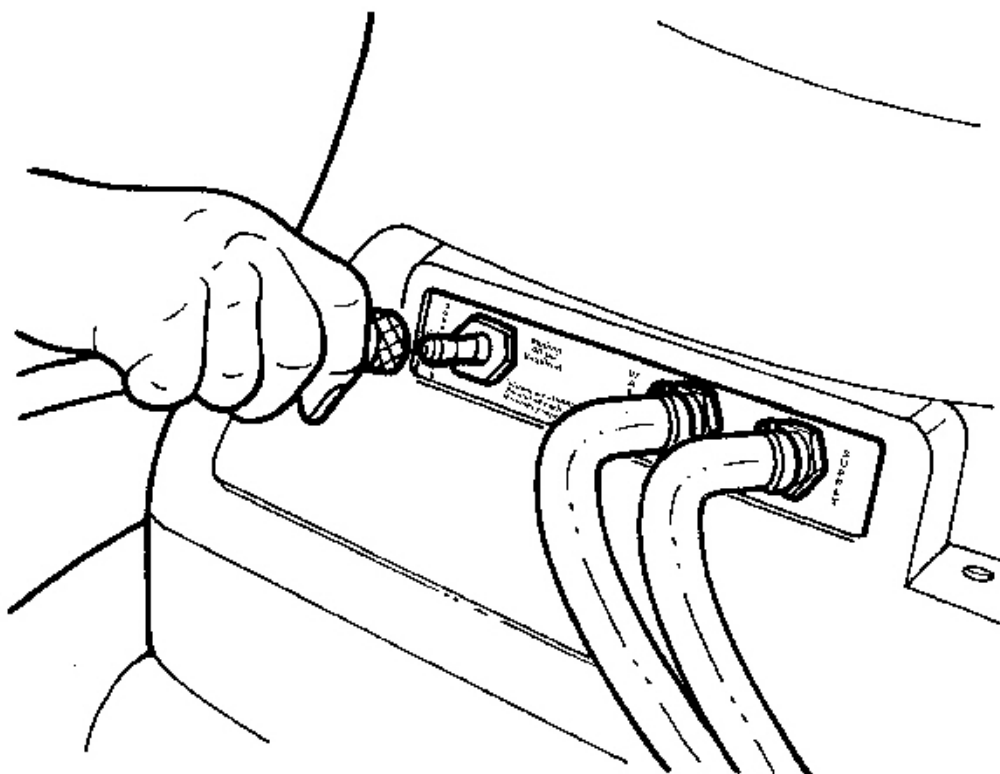

Fig. 22: Applying Shop Air Supply Hose To Quick-Disconnect
Courtesy of GENERAL MOTORS CORP.

4. Disconnect the air supply hose from **J 45096** . See **Special Tools**.
5. Dispose of the waste oil in accordance with all applicable federal, state and local requirements.

TRANSMISSION FLUID COOLER FLUSHING AND FLOW TEST (J 35944-A)

GM studies indicate that plugged or restricted transmission oil coolers and pipes cause insufficient transmission lubrication and elevated operating temperatures which can lead to

premature transmission wear-out. Many repeat repair cases could have been prevented by following published procedures for transmission oil cooler flushing and flow checking. This procedure includes flow checking and flushing the auxiliary transmission oil cooler, if equipped.

IMPORTANT: Use the J 35944-A or equivalent to flush the transmission oil cooler and the oil cooler pipes whenever the transaxle is removed for the following repairs. See Special Tools.

- Torque converter
- Oil pump
- Oil pump drive shaft
- Drive sprocket support
- Transaxle overhaul complete
- Transaxle assembly replacement

IMPORTANT: Use the J 35944-A or equivalent to flush the transmission oil cooler and the oil cooler pipes whenever the transmission is removed for the following repairs. See Special Tools.

- Torque converter
- Oil pump
- Turbine shaft
- Transmission overhaul complete
- Transmission assembly replacement

Only GM Goodwrench DEXRON®VI automatic transmission fluid should be used when doing a repair on a GM transmission.

Time allowance for performing the cooler flow checking and flushing procedure has been included in the appropriate labor time guide operations since the 1987 model year. The service procedure steps for oil cooler flushing are as follows:

Cooler Flow Check and Flushing Steps

1. Tools Required
2. Preparation
3. Back Flush

2007 Hummer H3

2007 TRANSMISSION Automatic Transmission - 4L60-E/4L65-E/4L70-E - H3

4. Forward Flush
5. Flow Check
6. Clean-up

Tools Required

- **J 35944-A** Transmission Oil Cooler Flusher. See **Special Tools**.
- **J 35944-22** Transmission Oil Cooler Flushing Fluid. See **Special Tools**.
- **J 35944-200** Cooler Flushing Adapter. See **Special Tools**.
- Measuring cup
- Funnel
- Water supply, hot water recommended
- Water hose, at least 16 mm (5/8 in) ID
- Shop air supply, with water/oil filters, regulator and pressure gage
- Air chuck, with clip if available
- Oil drain container
- Pail with lid 19 L (5 gallon)
- Eye protection
- Rubber gloves

Preparation

1. During the installation of the repaired or replacement transmission, do not connect the oil cooler pipes.

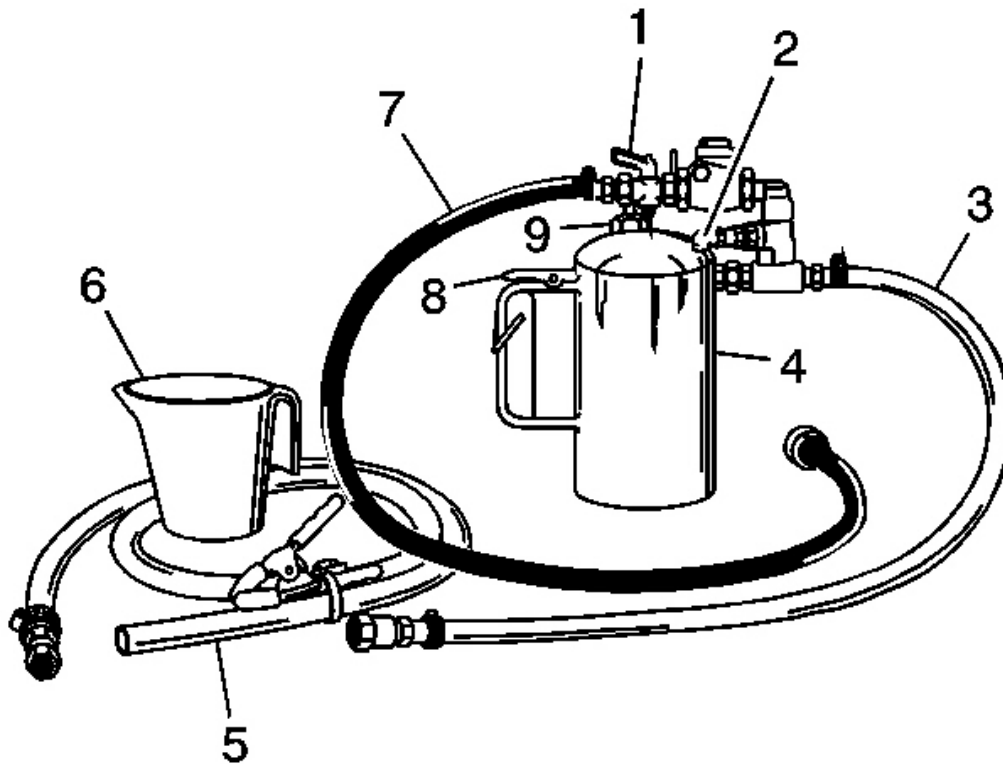

Fig. 23: Identifying Flusher Tank & Components
Courtesy of GENERAL MOTORS CORP.

NOTE: Do not use solutions that contain alcohol or glycol. Use of solutions that contain alcohol or glycol may damage the oil cooler line flusher, oil cooler components and/or transmission components.

IMPORTANT: The J 35944-22 is environmentally safe, yet powerful enough to cut through transmission fluid to dislodge any contaminants from the cooler. See Special Tools. The safety precautions on the label, regarding potential skin and eye irritations associated with prolonged exposure, are typical precautions that apply to many similar cleaning solutions. It should be noted that according to GM, use of other non-

approved fluids for cooler flushing can have an adverse reaction to the seals inside the transmission.

2. Remove the fill cap (9) on the **J 35944-A** and fill the flusher tank (4) with 0. See **Special Tools**. 6 L (20-21 oz.) of **J 35944-22** , using the measuring cup (6). See **Special Tools**. Do not overfill.
3. Install the fill cap (9) on the **J 35944-A** and pressurize the flusher tank (4) to 550-700 kPa (80-100 psi), using the shop air supply at the tank air valve (2). See **Special Tools**.
4. With the water supply valve (1) on the **J 35944-A** in the OFF position, connect the water supply hose from the **J 35944-A** to the water supply at the faucet. See **Special Tools**.
5. Turn ON the water supply at the faucet.

Back Flush

1. Inspect the transmission oil cooler pipes for kinks or damage. Repair as necessary.

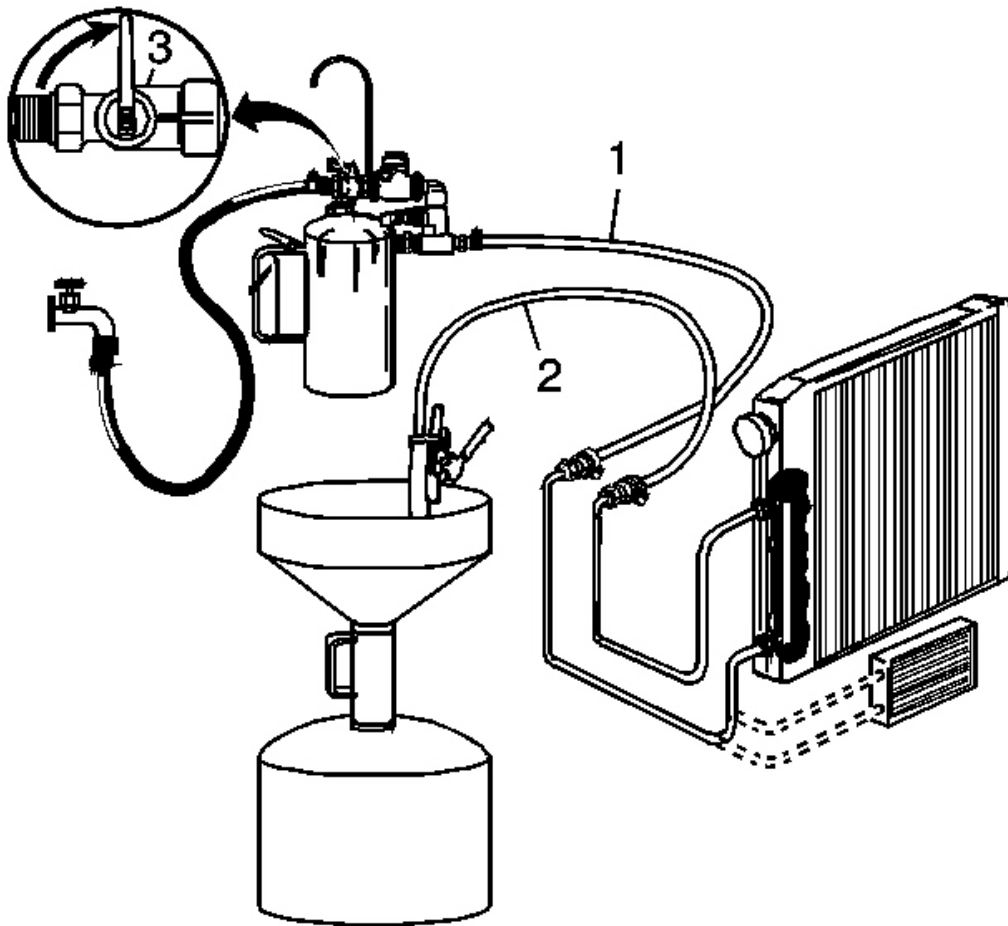

Fig. 24: Connecting J 35944 To Oil Cooler
 Courtesy of GENERAL MOTORS CORP.

2. Connect the **J 35944-A** to the oil cooler feed bottom connector. See **Special Tools**. Use the **J 35944-200** , if required.
3. Clip the discharge hose (2) onto the oil drain container.
4. Attach the **J 35944-A** to the undercarriage of the vehicle with the hook provided and connect the flushing system feed supply hose (1) from the **J 35944-A** to the top connector oil cooler return pipe. See **Special Tools**. Use the **J 35944-200** , if required.
5. Turn the **J 35944-A** water supply valve (3) to the ON position and allow water to flow through the oil cooler and pipes for 10 seconds to remove any remaining transmission fluid.

See **Special Tools**. If water does not flow through the oil cooler and pipes, the cause of the blockage must be diagnosed and the plugged component must be repaired or replaced. Continue with the cooler flushing and flow check procedure once the blockage is corrected.

6. Turn the **J 35944-A** water supply valve (3) to the OFF position and clip the discharge hose onto a 19 liter (5 gallon) pail with a lid, to avoid splashback. See **Special Tools**.

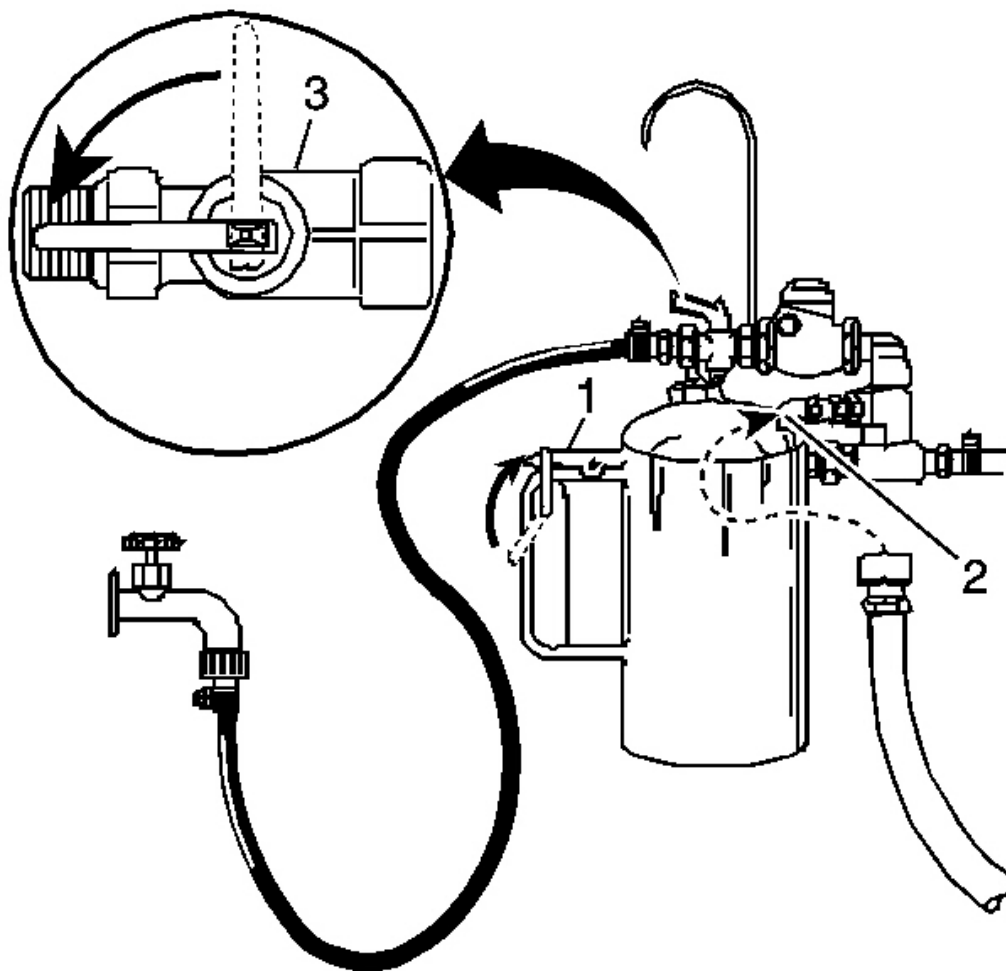

Fig. 25: Turning The J 35944-A Water Supply Valve To The ON Position
Courtesy of GENERAL MOTORS CORP.

IMPORTANT: Flushing for approximately 2 minutes in each cooler line direction will result in a total of about 30-38 L (8-10 gallons)

of waste fluid. This mixture of water and flushing fluid is to be captured in a bucket or similar container.

7. Turn the **J 35944-A** water supply valve (3) to the ON position and depress the trigger (1) to mix cooler flushing solution into the water flow. See **Special Tools**. Use the clip provided on the handle to hold the trigger (1) down. The discharge will foam vigorously when the solution is introduced into the water stream.
8. Flush the oil cooler and pipes with water and solution for 2 minutes. During this flush, attach the shop air supply 825 kPa (120 psi) to the flushing system feed air valve (2) located on the **J 35944-A** , for 3-5 seconds at the end of every 15-20 second interval to create a surging action. See **Special Tools**.
9. Release the trigger (1) and turn the **J 35944-A** water supply valve (3) to the OFF position. See **Special Tools**.

Forward Flush

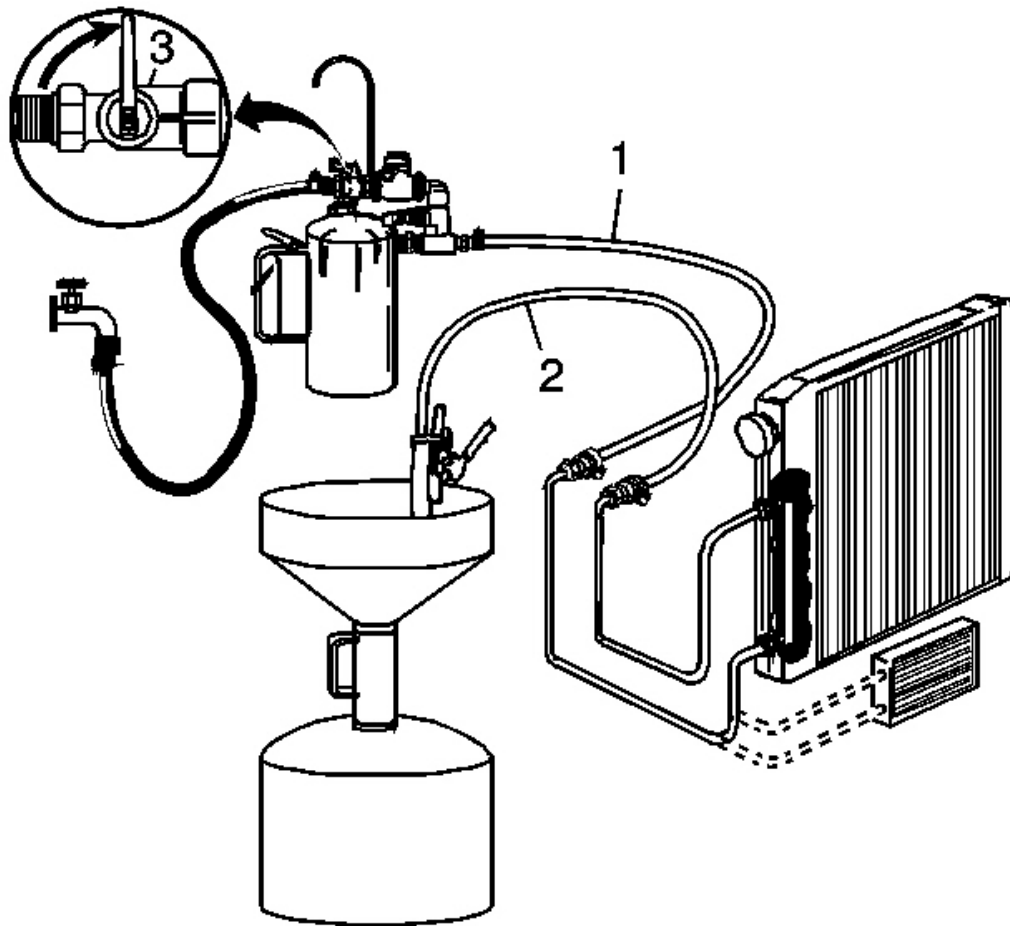

Fig. 26: Connecting J 35944 To Oil Cooler
Courtesy of GENERAL MOTORS CORP.

1. Disconnect both hoses (1 and 2) from the oil cooler pipes and connect them to the opposite oil cooler pipe. This will allow the oil cooler and pipes to be flushed in the normal flow direction.
2. Repeat Step 6 and 7 of the Back Flush.

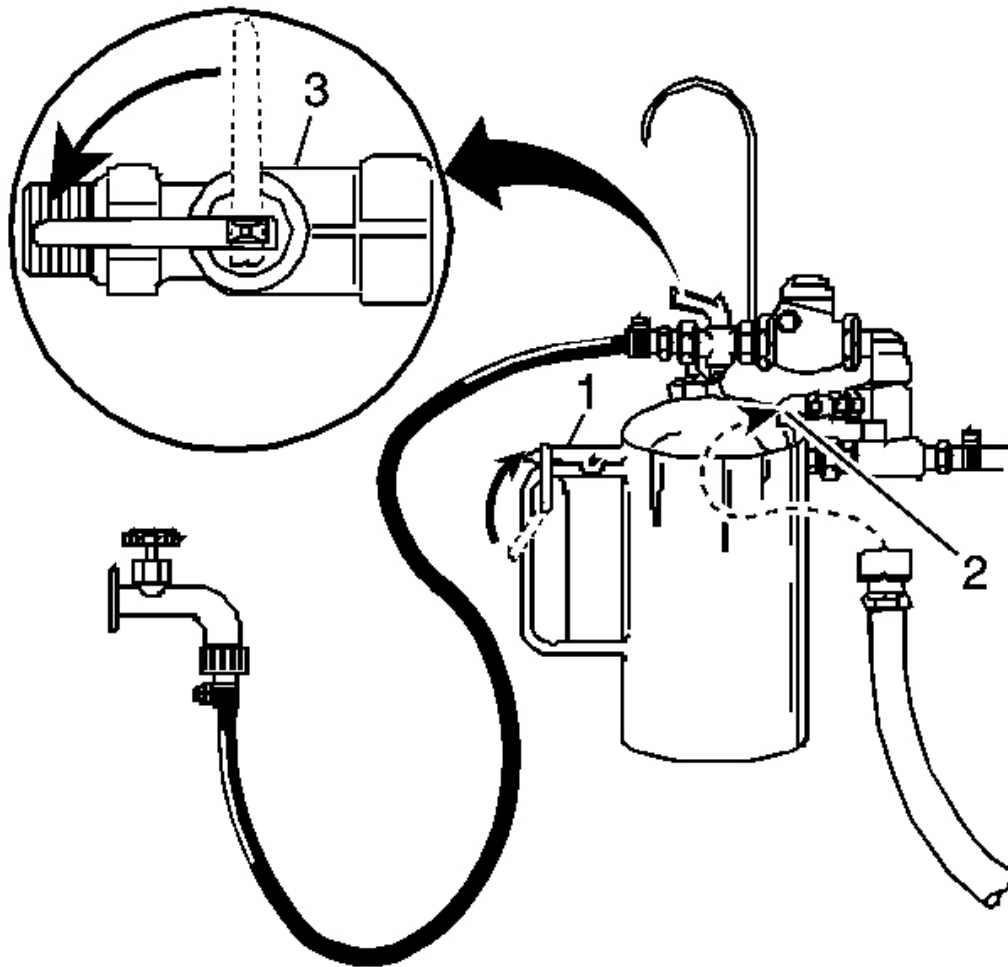

Fig. 27: Turning The J 35944-A Water Supply Valve To The ON Position
Courtesy of GENERAL MOTORS CORP.

3. Release the trigger (1) of the **J 35944-A** and allow water only to rinse the oil cooler and pipes for 1 minute. See **Special Tools**.
4. Turn the **J 35944-A** water supply valve (3) to the OFF position and turn OFF the water supply at the faucet. See **Special Tools**.
5. Attach the shop air supply to the flushing system feed air valve (2) on the **J 35944-A** and blow out the water from the oil cooler and pipes. See **Special Tools**. Continue, until no water comes out of the discharge hose.

Flow Test

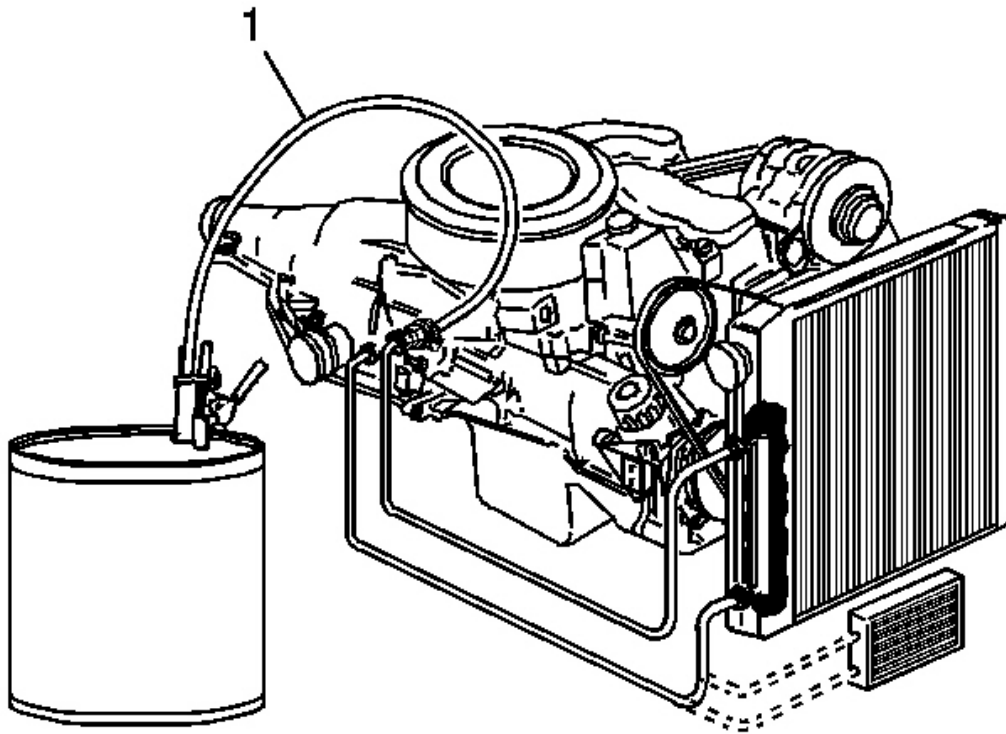

Fig. 28: Clipping The Discharge Hose To An Empty Oil Container
Courtesy of GENERAL MOTORS CORP.

IMPORTANT: The Flow Test must be performed after the flush to ensure that all flushing solution and water is removed from the oil cooling system.

1. Disconnect the hose from the oil cooler pipe. Connect the oil cooler feed pipe, bottom connector, to the transmission for normal flow.
2. Clip the discharge hose (1) to an empty oil container.
3. Confirm the transmission is filled with automatic transmission fluid. Refer to **Fluid Capacity Specifications** for the correct automatic transmission fluid capacity.
4. Start the engine with the transmission in PARK range and run for 30 seconds after fluid begins to flow from the discharge hose (1). A minimum of 1.9 L (2 qt) must be discharged

during this 30 second run time.

5. If the fluid flow meets or exceeds 1.9 L (2 quarts) in 30 seconds, connect the oil cooler feed pipe to the bottom connector on the transmission.
6. If fluid flow is less than 1.9 L (2 qt) in 30 seconds, perform the following diagnosis:
 1. Disconnect the **J 35944-A** discharge hose (1) from the oil cooler return pipe. See **Special Tools**.
 2. Disconnect the oil cooler feed pipe at the radiator.
 3. Connect the **J 35944-A** discharge hose (1) to the oil cooler feed pipe, radiator end. See **Special Tools**.
 4. Clip the discharge hose (1) onto the oil drain container.
 5. Start the engine with the transmission in PARK range and run for 30 seconds after fluid begins to flow from the discharge hose (1). A minimum of 1.9 L (2 qt) must be discharged during this 30 second run time.
7. If the amount of transmission fluid flow remains less than 1.9 L (2 qt) in 30 seconds, inspect the oil cooler feed pipe, bottom connector, for restrictions or damage. If no condition is found with the feed pipe, bottom connector, inspect the transmission.

Clean-up

1. Disconnect the water supply hose from the **J 35944-A** and bleed any remaining air pressure from the flusher tank. See **Special Tools**.
2. Remove the fill cap from the **J 35944-A** and return any unused flushing solution to its container. See **Special Tools**. Rinse the **J 35944-A** with water. See **Special Tools**. Do not store the **J 35944-A** with flushing solution in it.
3. After every third use, clean the **J 35944-A** as described in the instructions included with the tool. See **Special Tools**.
4. Dispose of any waste water/solution and transmission fluid in accordance with local regulations.

BUSHING AND MATING SHAFT INSPECTION

IMPORTANT: Proper bushing and corresponding mating shaft inspection should be performed before replacing the bushing, shaft and in some cases, the component which houses the bushing. Thoroughly clean and dry the bushing and shaft surfaces before inspecting for damage.

Any of the following bushing conditions require replacement of the bushing and/or housing:

2007 Hummer H3

2007 TRANSMISSION Automatic Transmission - 4L60-E/4L65-E/4L70-E - H3

- Discoloration due to heat distress
- Misalignment or displacement of bushing as a result of spinning in housing
- Medium to heavy scoring that can be easily detected with fingernail. Light scoring is a normal condition.
- Debris embedded into the bushing lining material
- Obvious damage, including excessive and uneven wear
- Excessive polishing. Minor polishing of the bushing is an indication of normal wear and does not require replacement.

Any of the following conditions require replacement of the bushing's mating shaft:

- Discoloration due to heat distress
- Rough surface finish that can be easily detected with finger
- Obvious shaft abnormalities, including warping or uneven surfaces
- Obvious damage or cracking

TRANSMISSION OVERHEATS

Transmission Overheats

Checks	Causes
TCC Circuit	Blockage during apply or release
Pump Cover (215)	Cross channel leakage
Pressure Regulator Valve (216)	The valve is stuck in a high demand position
Oil Cooler	The cooler or the cooler lines are blocked
Oil Pan Gasket (73)	The gasket is damaged
Turbine Shaft O-ring (618)	The O-ring is damaged
Turbine Shaft Seals (619)	The seals are damaged
Stator Shaft Bushings (234/241)	The bushing is worn or damaged
Fluid	The fluid level is low
Radiator	Air flow is restricted or internal blockage

OIL PRESSURE HIGH OR LOW

Oil Pressure High or Low

Checks	Causes
--------	--------

2007 Hummer H3

2007 TRANSMISSION Automatic Transmission - 4L60-E/4L65-E/4L70-E - H3

Oil Pump Assembly (4)	<ul style="list-style-type: none">• Pressure regulator valve stuck• Pressure regulator valve spring• Rotor guide omitted or misassembled• Rotor cracked or broken• Reverse boost valve or sleeve stuck, damaged or incorrectly assembled• Orifice hole in pressure regulator valve plugged• Sticking slide or excessive rotor clearance• Pressure relief ball not seated or damaged• Porosity in pump cover or body• Wrong pump cover• Pump faces not flat• Excessive rotor clearance
Oil Filter (72)	<ul style="list-style-type: none">• Intake pipe restricted by casting flash• Cracks in filter body or intake pipe• O-ring seal missing, cut or damaged• Wrong grease used on rebuild
Control Valve Body (60)	<ul style="list-style-type: none">• Manual valve scored or damaged• Spacer plate or gaskets incorrect, misassembled or damaged• Face not flat• 2-3 Shift valve stuck• Checkballs omitted or misassembled
Pressure Control Solenoid (377)	Damage to electrical terminals
Transmission Fluid Pressure Manual Valve Position Switch (69)	<ul style="list-style-type: none">• Contamination• Damaged seals
Case (103)	Case to control valve body face not flat
System Voltage	<ul style="list-style-type: none">• 12 volts not supplied to transmission• Electrical short (pinched solenoid wire)• Solenoid not grounded

2007 Hummer H3

2007 TRANSMISSION Automatic Transmission - 4L60-E/4L65-E/4L70-E - H3

HARSH SHIFTS

Harsh Shifts

Checks	Causes
Throttle Position Sensor	Open or shorted circuit
Vehicle Speed Sensor (36) or Input Speed Sensor (250)	Open or shorted circuit
Automatic Transmission Fluid Pressure (TFP) (69)	<ul style="list-style-type: none">• Contamination• Damaged seals
Trans Fluid Temperature Sensor (Part of 69)	Open or shorted circuit
Engine Coolant Temperature Sensor	Open or shorted circuit
Pressure Control Solenoid (377)	<ul style="list-style-type: none">• Damage to electrical terminals• Contamination

INACCURATE SHIFT POINTS

Inaccurate Shift Points

Checks	Causes
Oil Pump Assembly (4)	<ul style="list-style-type: none">• Stuck pressure regulator valve• Sticking pump slide
Valve Body Assembly (60) Case (103)	Spacer plate or gaskets misassembled, damaged or incorrect <ul style="list-style-type: none">• Porous or damaged valve body pad• 2-4 Servo Assembly<ul style="list-style-type: none">○ 2-4 accumulator porosity○ Damaged servo piston seals○ Apply pin damaged or improper length• 2-4 Band Assembly<ul style="list-style-type: none">○ Burned○ Anchor pin not engaged
Throttle Position Sensor	<ul style="list-style-type: none">• Disconnected• Damage
Vehicle Speed Sensor (36) or Input Speed Sensor (250)	<ul style="list-style-type: none">• Disconnected

2007 Hummer H3

2007 TRANSMISSION Automatic Transmission - 4L60-E/4L65-E/4L70-E - H3

	<ul style="list-style-type: none">• Damaged• Bolt not tightened
4WD Low Switch	<ul style="list-style-type: none">• Disconnected• Damaged

FIRST GEAR RANGE ONLY - NO UPSHIFT

1st Gear Range Only - No Upshift

Checks	Causes
Control Valve Body (60)	<ul style="list-style-type: none">• The 1-2 Shift valve is sticking• The spacer plate or gaskets are mispositioned or damaged
Case (103)	The case to valve body face is damaged or is not flat
Shift Solenoid Valves (366/368)	<ul style="list-style-type: none">• Stuck or damaged• Faulty electrical connection
2-4 Servo Assembly (13-28)	<ul style="list-style-type: none">• The apply passage case is restricted or blocked• Nicks or burrs on the servo pin or on the pin bore in the case• Fourth servo piston is installed backwards
2-4 Band Assembly (602)	<ul style="list-style-type: none">• The 2-4 band is worn or damaged• The band anchor pin is not engaged

SLIPS IN FIRST GEAR

Slips in 1st Gear

Checks	Causes
Forward Clutch Assembly (646-651)	<ul style="list-style-type: none">• Clutch plates worn• Porosity or damage in forward clutch piston• Forward clutch piston inner and outer seals missing, cut or damaged• Damaged forward clutch housing• Forward clutch housing retainer and ball assembly not sealing or damaged
Forward Clutch	<ul style="list-style-type: none">• Piston seal missing, cut or damaged

2007 Hummer H3

2007 TRANSMISSION Automatic Transmission - 4L60-E/4L65-E/4L70-E - H3

Accumulator (353-358)	<ul style="list-style-type: none"> ● Piston out of its bore ● Porosity in the piston or valve body ● Stuck abuse valve
Input Housing and Shaft Assembly (621)	Turbine shaft seals missing, cut or damaged
Valve Body (60)	<ul style="list-style-type: none"> ● 1-2 Accumulator valve stuck ● Face not flat, damaged lands or interconnected passages ● Spacer plate or gaskets incorrect, mispositioned or damaged
Low Roller Clutch (678)	<ul style="list-style-type: none"> ● Damage to lugs to inner ramps ● Rollers not free moving ● Inadequate spring tension ● Damage to inner splines ● Lube passage plugged
Torque Converter (1)	Stator roller clutch not holding
1-2 Accumulator Assembly (55-57, 104)	<ul style="list-style-type: none"> ● Porosity in piston or 1-2 Accumulator cover and pin assembly ● Damaged ring grooves on piston ● Piston seal missing, cut or damaged ● Valve body to spacer plate gasket at 1-2 Accumulator cover, missing or damaged ● Leak between piston and pin ● Broken 1-2 Accumulator spring
Line Pressure	Refer to <u>Oil Pressure High or Low.</u>
2-4 Servo Assembly (13-28)	4th Servo piston in backward

SLIPPING OR HARSH 1-2 SHIFT

Slipping or Rough 1-2 Shift

Checks	Causes
Valve Body Assembly (60)	<ul style="list-style-type: none"> ● Mislocated valve body to spacer plate checkball or checkballs. ● 1-2 Shift valve train stuck due to sediment ● Gaskets or spacer plate incorrect, mispositioned or

2007 Hummer H3

2007 TRANSMISSION Automatic Transmission - 4L60-E/4L65-E/4L70-E - H3

	<p>damaged</p> <ul style="list-style-type: none"> • 1-2 Accumulator valve stuck or damaged • Face not flat • 4-3 sequence valve stuck or damaged • #1 or #8 checkball missing or mis-located • 1-2 accumulator valve bushing rotated 180°
2-4 Servo Assembly (13-28)	<ul style="list-style-type: none"> • Apply pin too long or too short • 2nd servo apply piston seal missing, cut or damaged • Restricted or missing oil passages • Servo bore in case damaged
2nd Accumulator (55-57, 104)	<ul style="list-style-type: none"> • Porosity in 1-2 accumulator cover or piston • Piston seal or groove damaged • Nicks or burrs in 1-2 accumulator housing • Missing or restricted oil passage • 1-2 accumulator piston spring not seated • Rough finish in 1-2 accumulator bore in case • A cracked 1-2 accumulator piston - allowing fluid to leak by
2-4 Band (602)	Worn or mispositioned
Oil Pump Assembly (4) or Case (103)	Faces not flat

NO 2-3 SHIFT OR 2-3 SHIFT SLIPS, ROUGH OR HUNTING

No 2-3 Shift or 2-3 Shift slipping, Rough or Hunting

Checks	Causes
Oil Pump (4)	Stator shaft bushings scored or off location
Valve Body Assembly (60)	<ul style="list-style-type: none"> • 2-3 Shift valve train stuck • Gaskets or spacer plate incorrect, mispositioned or damaged • 2-3 Accumulator valve stuck • Face not flat • Chips in servo feed oil, orifice #7 in spacer plate • Mislocated valve body to spacer plate checkball or

2007 Hummer H3

2007 TRANSMISSION Automatic Transmission - 4L60-E/4L65-E/4L70-E - H3

	checkballs
Input Housing Assembly (620-621, 646-655)	<ul style="list-style-type: none"> • 3-4 clutch or forward clutch plates worn • Excessive clutch plate travel • Cut or damaged 3-4 clutch or forward clutch piston seals • Porosity in input clutch housing or piston • 3-4 clutch piston checkball stuck, damaged or not sealing • Restricted apply passages • Forward clutch piston retainer and ball assembly not seating • Sealing balls loose or missing • Input housing (621) cracked or broken
Case (103)	3rd accumulator retainer and ball assembly not seating
2-4 Servo Assembly (13-28)	2nd apply piston seals missing, cut or damaged

SECOND/THIRD GEAR ONLY OR FIRST/FOURTH GEARS ONLY**Second/Third Gears Only or First/Fourth Gears Only**

Checks	Causes
1-2 Shift Solenoid Valve (367A)	<ul style="list-style-type: none"> • Sediment is in the valves • The electrical connection is faulty • Damaged seal

NO FIRST OR SECOND GEAR/NO THIRD OR FOURTH GEAR**No 1st or 2nd/No 3rd or 4th**

Checks	Causes
2-3 Shift Solenoid Valve (367B)	<ul style="list-style-type: none"> • Sediment is in the valves • The electrical connection is faulty • Damaged seal

NO SECOND GEAR, NO FOURTH GEAR AND NO REVERSE GEAR**No Second Gear, No Fourth Gear and No Reverse Gear**

Checks	Causes
Reaction Sun Shell (670)	Broken spline on reaction sun shell/replace shell.

2007 Hummer H3

2007 TRANSMISSION Automatic Transmission - 4L60-E/4L65-E/4L70-E - H3

THIRD GEAR ONLY

Third Gear Only

Checks	Causes
System Voltage	<ul style="list-style-type: none">• 12 volts not supplied to transmission• Electrical short (pinched solenoid wire)• Solenoid not grounded

3-2 FLARE OR TIE-UP

3-2 Flare or Tie-Up

Checks	Causes
3-2 Shift Solenoid Valve Assembly (394)	<ul style="list-style-type: none">• Shorted or damaged• Contamination• Damaged Seal• Check ball not seating

NO 3-4 SHIFT, SLIPS OR ROUGH 3-4 SHIFT

No 3-4 Shift/Slipping or Rough 3-4 Shift

Checks	Causes
Oil Pump Assembly (4)	<ul style="list-style-type: none">• Pump cover retainer and ball assembly omitted or damaged• Faces not flat
Valve Body Assembly (60)	<ul style="list-style-type: none">• Valves stuck<ul style="list-style-type: none">○ 2-3 Shift valve train○ Accumulator valve○ 1-2 Shift valve train○ 3-2 Shift solenoid valve assembly• Spacer plate or gaskets incorrect, mispositioned or damaged
2-4 Servo Assembly (13-28)	<ul style="list-style-type: none">• Incorrect band apply pin• Missing or damaged servo seals• Porosity in piston, cover or case• Damaged piston seal grooves

2007 Hummer H3

2007 TRANSMISSION Automatic Transmission - 4L60-E/4L65-E/4L70-E - H3

	<ul style="list-style-type: none"> ● Plugged or missing orifice cup plug
Case (103)	<ul style="list-style-type: none"> ● 3rd Accumulator retainer and ball assembly leaking ● Porosity in 3-4 accumulator piston or bore ● 3-4 Accumulator piston seal or seal grooves damaged ● Plugged or missing orifice cup plug ● Restricted oil passage
Input Housing Assembly (621)	Refer to <u>No 2-3 Shift or 2-3 Shift Slips, Rough or Hunting.</u>
2-4 Band Assembly (602)	Worn or misassembled

NO REVERSE OR SLIPS IN REVERSE

No Reverse or Slips in Reverse

Checks	Causes
Input Housing Assembly (602)	<ul style="list-style-type: none"> ● 3-4 Apply ring stuck in applied position ● Forward clutch not releasing ● Turbine shaft seals missing, cut or damaged
Manual Valve Link (89)	Disconnected
Valve Body Assembly (60)	<ul style="list-style-type: none"> ● 2-3 Shift valve stuck ● Manual linkage not adjusted ● Spacer plate and gaskets incorrect, mispositioned or damaged ● Lo overrun valve stuck ● Orificed cup plug restricted, missing or damaged
Reverse Input Clutch Assembly (605-614)	<ul style="list-style-type: none"> ● Clutch plate worn ● Reverse input housing and drum assembly cracked at weld ● Clutch plate retaining ring out of groove ● Return spring assembly retaining ring out of groove ● Seals cut or damaged ● Restricted apply passage ● Porosity in piston ● Belleville plate installed incorrectly

2007 Hummer H3

2007 TRANSMISSION Automatic Transmission - 4L60-E/4L65-E/4L70-E - H3

	<ul style="list-style-type: none"> ● Excessive clutch plate travel ● Oversized housing
Lo and Reverse Clutch (694-696)	<ul style="list-style-type: none"> ● Clutch plates worn ● Porosity in piston ● Seals damaged ● Return spring assembly retaining ring mispositioned ● Restricted apply passage
Reaction Sun Shell (670)	Broken spline on reaction sun shell/replace shell

NO PART THROTTLE OR DELAYED DOWNSHIFTS

No Part Throttle or Delayed Downshifts

Checks	Causes
Input Housing Assembly (621)	<ul style="list-style-type: none"> ● 3-4 Apply ring stuck in applied position ● Forward clutch not releasing ● Turbine shaft seals missing, cut or damaged
Manual Valve Link (89)	Disconnected
Valve Body Assembly (60)	<ul style="list-style-type: none"> ● 2-3 Shift valve stuck ● Manual linkage not adjusted ● Spacer plate and gaskets incorrect, mispositioned or damaged ● Lo overrun valve stuck ● Orificed cup plug restricted, missing or damaged
Reverse Input Clutch Assembly (606-614)	<ul style="list-style-type: none"> ● Clutch plate worn ● Reverse input housing and drum assembly cracked at weld ● Clutch plate retaining ring out of groove ● Return spring assembly retaining ring out of groove ● Seals cut or damaged ● Restricted apply passage ● Porosity in piston ● Belleville plate installed incorrectly ● Excessive clutch plate travel

2007 Hummer H3

2007 TRANSMISSION Automatic Transmission - 4L60-E/4L65-E/4L70-E - H3

	<ul style="list-style-type: none">• Oversized housing
Lo and Reverse Clutch (694-696)	<ul style="list-style-type: none">• Clutch plates worn• Porosity in piston• Seals damaged• Return spring assembly retaining ring mispositioned• Restricted apply passage

HARSH GARAGE SHIFT

Harsh Garage Shift

Checks	Causes
Valve Body Assembly (60)	<ul style="list-style-type: none">• Orifice cup plug missing• Checkball missing

NO OVERRUN BRAKING - MANUAL 3-2-1

No Overrun Braking - Manual 3-2-1

Checks	Causes
External Linkage	Not adjusted properly
Valve Body Assembly (60)	<ul style="list-style-type: none">• 4-3 Sequence valve stuck• Checkball mispositioned• Spacer plate and gaskets incorrect, damaged or mispositioned
Overrun and Forward Clutch Assembly (644-651)	<ul style="list-style-type: none">• Turbine shaft oil passages plugged or not drilled• Turbine shaft seal rings damaged• Turbine shaft sealing balls loose or missing• Porosity in forward or overrun clutch piston• Overrun piston seals cut or damaged• Overrun piston checkball not sealing

NO TORQUE CONVERTER CLUTCH APPLY (300 RPM SLIP)

No Torque Converter Clutch (TCC) Apply

Checks	Causes
Valve Body Assembly (60)	<ul style="list-style-type: none">• Regulator apply valve side loading

2007 Hummer H3

2007 TRANSMISSION Automatic Transmission - 4L60-E/4L65-E/4L70-E - H3

	<ul style="list-style-type: none"> ● Stuck converter clutch valve ● Torque converter clutch (TCC) apply valve stuck closed (debris in bore) ● Torque converter clutch pulse width modulated (TCC PWM) solenoid broken/cracked ● Turbine shaft O-ring omitted ● TCC PWM solenoid leaking
Input Housing and Turbine Shaft Assembly (621)	<ul style="list-style-type: none"> ● Turbine shaft hole not drilled to full depth ● Scratched turbine shaft journals ● Turbine shaft O-ring omitted/damaged ● Turbine shaft retainer and ball assembly restricted or damaged
Electrical	<ul style="list-style-type: none"> ● 12 volts not supplied to transmission ● Outside electrical connector damaged ● Inside electrical connector damaged ● Wire harness damaged ● TCC solenoid damaged ● Electrical short (pinched wire) ● TCC solenoid not grounded
Torque Converter Clutch (1)	Internal damage (blue or distorted)
Oil Pump Assembly (4)	<ul style="list-style-type: none"> ● TCC spring cocked ● Orifice cup plug restricted or damaged ● Pump to case gasket mispositioned ● Converter clutch valve retaining ring mispositioned ● Converter clutch valve stuck or assembled backward
Transmission Fluid Pressure Manual Valve Position Switch (69)	<ul style="list-style-type: none"> ● Contamination ● Damaged seals
Solenoid Screen (367A/367B)	Blocked
TCC Solenoid Valve (Part of 66)	Internal damage
Engine Speed Sensor	Internal damage

2007 Hummer H3

2007 TRANSMISSION Automatic Transmission - 4L60-E/4L65-E/4L70-E - H3

Engine Coolant Temperature Sensor	Internal damage
Automatic Transmission Fluid Temperature Sensor (Part of 69)	Internal damage
Brake Switch	Internal damage
TCM	Internal damage
TCC PWM Solenoid (Part of 66)	Internal damage

TORQUE CONVERTER CLUTCH SHUDDER

Torque Converter Clutch Shudder

Checks	Causes
Miscellaneous	<ul style="list-style-type: none">• Low oil pressure• Engine not tuned properly• Contaminated transmission oil
Oil Filter (72)	<ul style="list-style-type: none">• Crack in filter body• Flash restricting filter neck• O-ring seal (71) cut or damaged
Torque Converter Assembly (1)	<ul style="list-style-type: none">• Internal damage• Broken weld or missing weight
Oil Pump Assembly (4)	<ul style="list-style-type: none">• Converter clutch valve (224) stuck• Restricted oil passage
Input Housing and Shaft Assembly (621)	<ul style="list-style-type: none">• Turbin shaft O-ring (618) cut or damaged• Turbin shaft retainer and ball assembly (617) restricted or damaged

NO TORQUE CONVERTER CLUTCH RELEASE

No TCC Release

Checks	Causes
TCC Solenoid Valve (Part of 66)	<ul style="list-style-type: none">• External ground• Clogged exhaust orifice
Converter (1)	Internal damage

2007 Hummer H3

2007 TRANSMISSION Automatic Transmission - 4L60-E/4L65-E/4L70-E - H3

Valve Body Assembly (60)	The converter clutch apply valve is stuck in the apply position
Oil Pump Assembly (4)	The converter clutch valve is stuck
PCM/TCM	External ground

TORQUE CONVERTER CLUTCH SLIP - 100 RPM SLIP**TCC Slip (100 RPM)**

Checks	Causes
Valve Body Assembly (60)	<ul style="list-style-type: none"> • TCC/PWM solenoid leaks • Regulator apply valve or converter clutch shift valve sticking or side loading
Oil Pump Assembly (4)	<ul style="list-style-type: none"> • Stator shaft bushings worn, due to scratched turbine shaft journal (replace bushings and input housing assembly) • TCC apply valve is stuck open • TCC solenoid leaking
Input Housing and Turbine Shaft Assembly (621)	<ul style="list-style-type: none"> • Scratched journal on turbine shaft • Turbine shaft O-ring cut • Turbine shaft hole not drilled to full depth

TORQUE CONVERTER CLUTCH SLIP WITH STALL/STUMBLE**TCC Slip with Stall/Stumble**

Checks	Causes
TCC Apply Valve (Part of 66)	Stuck open

TORQUE CONVERTER CLUTCH INTERMITTENT - OK COLD/SLIPS HOT**Intermittent TCC OK Cold/Slips Hot**

Checks	Causes
TCC PWM Solenoid (396)	Leaks
Regulator Apply Valve (216)	Sticking valve
Converter Clutch Shift Valve (224)	Sticking valve

NO FOURTH GEAR OR SLIPS IN FOURTH GEAR

2007 Hummer H3

2007 TRANSMISSION Automatic Transmission - 4L60-E/4L65-E/4L70-E - H3

No 4th or Slipping 4th

Checks	Causes
Checkball #2, 4, 8 or 12	Valve body checkball in wrong location or an additional checkball is installed. Refer to <u>Control Valve Body Installation</u> .
Orificed Cup Plug (240)	Not fully pressed into pump cover. Refer to <u>Oil Pump Stator Shaft Bushing Replacement</u> .

SLIP/FLARE IN ANY GEAR

Slip/Flare in any Gear

Checks	Causes
Pump Slide Spring (245)	Omitted, weak or broken

NO THIRD GEAR

No 3rd

Checks	Causes
Orificed Cup Plug (698)	Missing or blown out

DRIVES IN NEUTRAL

Drives in Neutral

Checks	Causes
Forward Clutch (446-451)	The clutch does not release
Manual Valve Link (89)	Disconnected
Case (103)	<ul style="list-style-type: none">• The face is not flat• Internal leakage exists

SECOND GEAR START

Second Gear Start

Checks	Causes
Signal Noise on Vehicle Speed Sensor (VSS) Circuit	Chassis vibrations, incorrect harness routing, owner installed electronic components creating electrical interference.
Diagnostic Trouble Code (DTC)	<ul style="list-style-type: none">• Electrical or mechanical 1-2 Shift Solenoid Valve (367) malfunction.• Sediment in the valve body may cause improper

2007 Hummer H3

2007 TRANSMISSION Automatic Transmission - 4L60-E/4L65-E/4L70-E - H3

	transmission fluid pressure (TFP) operation.
Leaking Actuator Feed Limit (AFL) Circuit	Spacer plate (48), spacer plate gaskets (47 or 52), control valve body (60), mispositioned, damaged or poor sealing/mating surface exist.
Blocked or restricted Valve Body Spacer Plate (48) Spacer Plate to Case Gasket (47) or Spacer Plate to Valve Body Gasket (52)	Trapped sediment or metal particles.
Stuck 1-2 Shift Valve (366)	<ul style="list-style-type: none"> • Trapped sediment or metal particles. • Binding shift valve or worn valve body bore.
TFP manual valve position switch (69)	TFP manual valve position switch (69) erratic operation.

NO PARK**No Park**

Checks	Causes
Parking Lock Actuator Linkage (85-90)	<ul style="list-style-type: none"> • Actuator rod assembly bent or damaged • Actuator rod spring binding or improperly crimped • Actuator rod not attached to inside detent lever • Parking lock bracket damaged or not torqued properly • Inside detent lever not torqued properly • Parking pawl binding or damaged

OIL OUT THE VENT**Oil Out the Vent**

Checks	Causes
Oil Pump (4)	Chamber in pump body rotor pocket
Miscellaneous	Fluid level-overfilled

VIBRATION IN REVERSE AND WHINING NOISE IN PARK**Vibration in Reverse and Whining Noise in Park**

Checks	Causes
Oil Pump (4)	Chamber in pump body rotor pocket

2007 Hummer H3

2007 TRANSMISSION Automatic Transmission - 4L60-E/4L65-E/4L70-E - H3

Miscellaneous Fluid level-overfilled

RATCHETING NOISE

Ratcheting Noise

Checks	Causes
Parking Brake Pawl (50-81)	The parking pawl return spring is weak, damaged or misassembled

TICKING NOISE IN REVERSE

Ratcheting Noise

Checks	Causes
Parking Brake Pawl (50-81)	<p>This noise may be caused by a bent parking lock actuator assembly (85). A bent actuator may not fully move the pawl (81) away from the internal reaction gear (684) when in reverse allowing the pawl to lightly contact the teeth of the internal reaction gear. The condition may not occur in forward gears as the additional actuator travel moves the pawl further from the gear teeth.</p> <p>To correct this condition, replace the parking lock actuator assembly (85).</p>

POPPING NOISE

Popping Noise

Checks	Action
DEFINITION: A popping noise, similar to popcorn popping	
Oil Pump System	<ul style="list-style-type: none">• Check fluid level.• Inspect for pump cavitation, indicated by bubbles in fluid.• Inspect the transmission fluid filter for a leaky seam.• Inspect the transmission fluid filter seal for improper positioning or for a cut seal.

WHINE NOISE VARYING WITH RPM OR FLUID PRESSURE

Whine Noise Varying with RPM or Fluid Pressure

--	--

2007 Hummer H3

2007 TRANSMISSION Automatic Transmission - 4L60-E/4L65-E/4L70-E - H3

Checks	Action
DEFINITION: In all ranges, a whine which may be sensitive to RPM load or which ceases when the TCC engages or which is sensitive to the oil pressure	
Torque Converter (1)	Verify that the noise is internal to the torque converter by placing your left foot on the brake with the gear or selector in Drive. Momentarily stall the engine. Torque Converter noise increases under load.
Oil Pump System	Verify that the noise is internal to the oil pump during a preliminary oil pressure check. An increase in line pressure will vary an oil pump noise.

BUZZ NOISE OR HIGH FREQUENCY RATTLE SOUND

Buzz Noise or High Frequency Rattle Sound

Checks	Action
DEFINITION: A buzz or high frequency rattle	
<ul style="list-style-type: none">Trace Cooler PipesCheck for binding or contact at the Radiator, other than at the Cooler Pipe connectors	Verify a pressure buzz by watching for a needle vibration of the pressure gage. A road test may be necessary. Refer to Road Test .

NOISE IN RANDOM RANGES

Noise in Random Ranges

Checks	Action
DEFINITION: Noise only in certain gear ranges	
Refer to Range Reference . Determine the power flow and the applicable components that may be causing this noise.	

NO DRIVE IN ALL RANGES

No Drive in All Ranges

Checks	Causes
Low Transmission Fluid Level	Transmission or cooler line leak
Oil Pump (4)	Damaged oil pump rotor (212)

2007 Hummer H3

2007 TRANSMISSION Automatic Transmission - 4L60-E/4L65-E/4L70-E - H3

Torque Converter (1)

- The converter is not bolted to flex plate
- Damaged pump drive
- The stator roller clutch is not holding

NO DRIVE IN DRIVE RANGE

No Drive in Drive Range

Checks	Causes
Oil Pump (4)	<ul style="list-style-type: none">• Damaged vanes• Missing slide spring• Oil pump screen assembly plugged or damaged• Oil pump rotor guide omitted or misassembled• Oil pump rotor cracked or broken• Porosity in fluid pump• Oil pump surfaces not flat• Excessive oil pump rotor clearance
Forward Sprag Clutch Assembly (642)	<ul style="list-style-type: none">• Damaged sprag• Worn or pitted inner race
Input (662) and Reaction (681) Carrier	Damaged or worn gears

SHIFT LEVER INDICATES WRONG GEAR

Shift Lever Indicates Wrong Gear

Checks	Causes
Manual Valve (340)	Not engaged to detent lever
Detent Roller Pin (63)	Missing or damaged
Detent Roller (63)	Broken or disconnected
Detent Spring (63)	Broken or disconnected
Manual Valve Link (89)	Loose or missing
Manual Shaft (84)	Flats not parallel
Indicator Linkage	Misadjusted

NO GEAR SELECTION

No Gear Selection

2007 Hummer H3

2007 TRANSMISSION Automatic Transmission - 4L60-E/4L65-E/4L70-E - H3

Checks	Causes
Detent Lever (63)	Nut loose or missing
Manual Valve (84)	Stuck
Spacer Plate/Gaskets (47, 48, 52)	Blocked holes
Control Valve Body to Case (60/103)	Blocked channels

ENGINE STARTS IN GEAR

Engine Starts in Gear

Checks	Causes
Manual Valve (24)	Not engaged to detent lever
Transmission Range Switch	Not working or mispositioned

DELAY IN DRIVE AND REVERSE

Delay in Drive and Reverse

Checks	Causes
Forward Clutch Piston (630)	Cut or damaged piston seals
Low and Reverse Clutch Piston (695)	Cut or damaged inner, outer or center clutch seals
Reverse Input Clutch Piston Assembly (607)	Cut or damaged inner or outer clutch seals
Pump Cover (215)	Cut or damaged oil seal rings - stator shaft

LACK OF POWER OR HESITATION

Lack of Power or Hesitation

Checks	Causes
Automatic Transmission Fluid Pressure (TFP) Manual Valve Position Switch (69)	Incorrect TFP signal logic for current gear position. Refer to <u>Transmission Fluid Pressure Manual Valve Position Switch Logic</u> .

REPAIR INSTRUCTIONS - ON VEHICLE

FLOOR SHIFT CONTROL KNOB REPLACEMENT

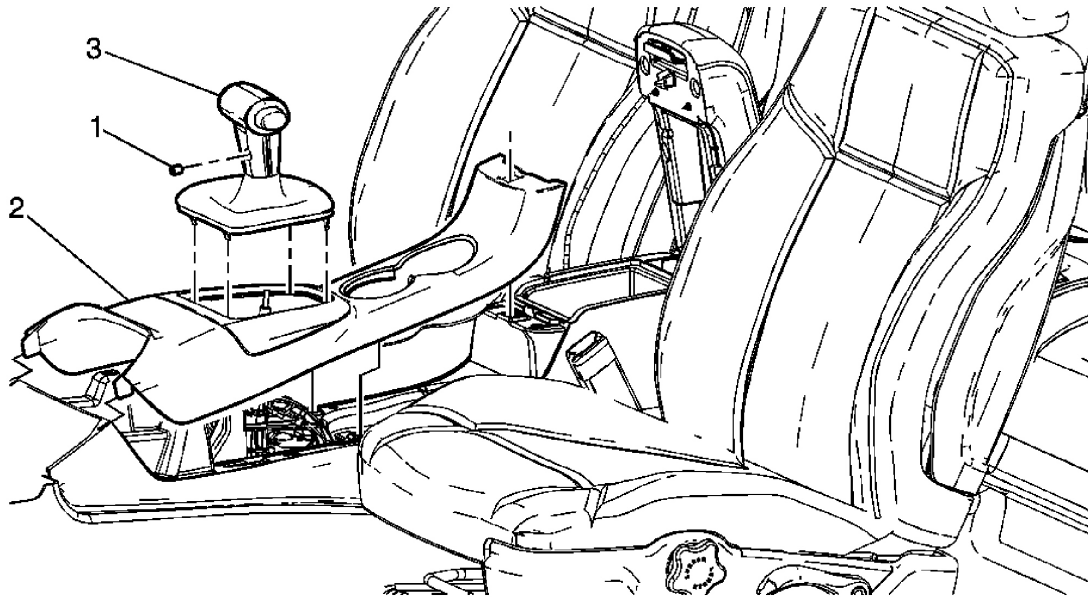

Fig. 29: Floor Shift Control Knob Replacement
 Courtesy of GENERAL MOTORS CORP.

Floor Shift Control Knob Replacement

Callout	Component Name
<p>NOTE: Refer to <u>Fastener Notice</u> .</p>	
<p>NOTE: Do NOT pull or pry on the shift boot. This action may damage the shift boot retainers.</p>	
<p>Fastener Tightening Specifications: Refer to <u>Fastener Tightening Specifications</u> .</p>	
<p>Preliminary Procedures</p>	
<ol style="list-style-type: none"> 1. Open the console compartment door. 2. Apply the parking brake. 3. Place the shift lever in NEUTRAL position. 	
<p>1</p>	<p>Shift Lever Handle Screw Tighten: 4 N.m (35 lb in)</p>

2007 Hummer H3

2007 TRANSMISSION Automatic Transmission - 4L60-E/4L65-E/4L70-E - H3

2	<u>Upper Trim Plate Console-Refer to Front Floor Upper Console Trim Plate Replacement (LHD w/Automatic Transmission) or Front Floor Upper Console Trim Plate Replacement (LHD w/Manual Transmission) or Front Floor Upper Console Trim Plate Replacement (RHD w/Automatic Transmission) or Front Floor Upper Console Trim Plate Replacement (RHD w/Manual Transmission)</u>
3	Shift Lever Handle Tip: The console shift bezel retainers must be released from the underside of the console upper trim plate.

AUTOMATIC TRANSMISSION RANGE SELECTOR LEVER CABLE REPLACEMENT

Removal Procedure

1. Ensure the vehicle is in the park position.
2. Raise and support the vehicle. Refer to **Lifting and Jacking the Vehicle** .

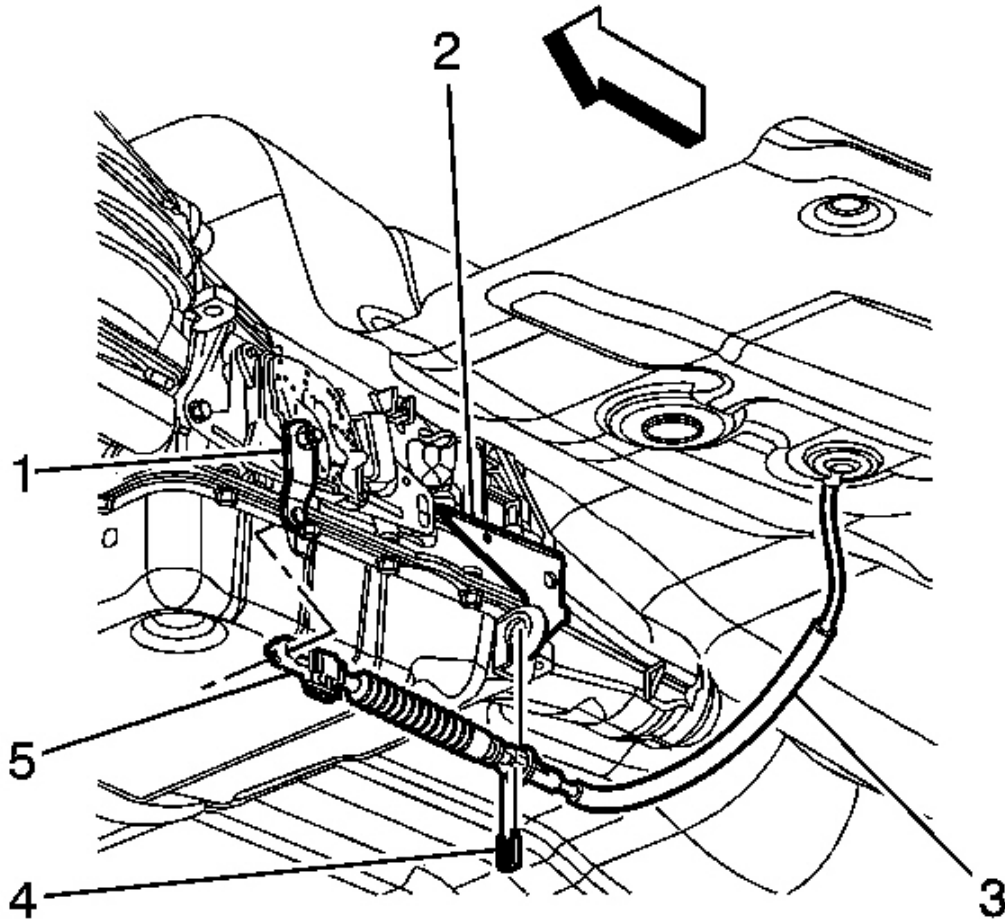

Fig. 30: View Of Range Selector Cable & Components
Courtesy of GENERAL MOTORS CORP.

IMPORTANT: Do not pull on the boot portion of the cable.

3. Complete the following in order to disconnect the range selector cable (3) from the transmission range selector lever ball stud.
 1. Insert a flat-bladed tool between the range selector cable end (5) and the range selector lever (1).
 2. Pry the range selector cable end (5) away from the range selector lever (1).
4. Remove the retainer (4) from the range selector cable (3).

5. Push the range selector cable locking tabs inward toward each other to release from the bracket (2).
6. Lower the vehicle.
7. Remove the cowl side trim panel. Refer to **Cowl Side Trim Panel Replacement** .
8. Pull the driver side carpet up, enough to access the range selector cable.

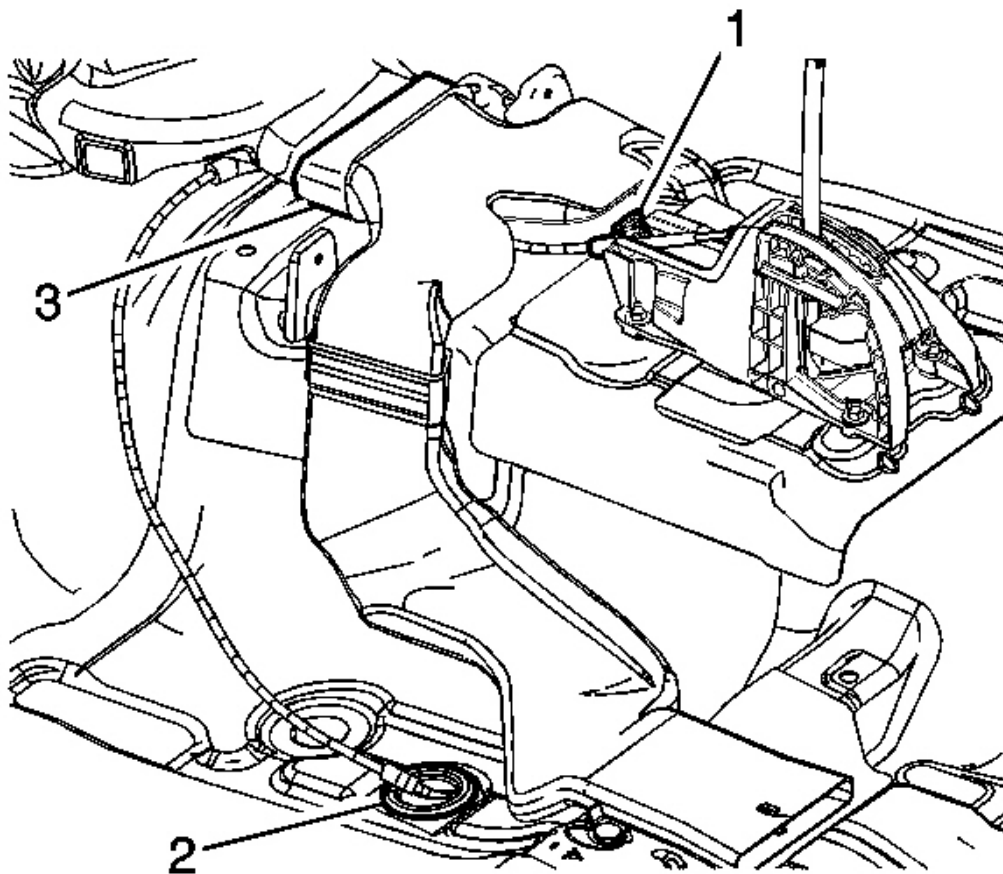

Fig. 31: Identifying Cable & Floor Panel Grommet
Courtesy of GENERAL MOTORS CORP.

9. Pull the cable grommet (2) up through the floor panel.
10. Make note of the cable routing under the heat duct (3).

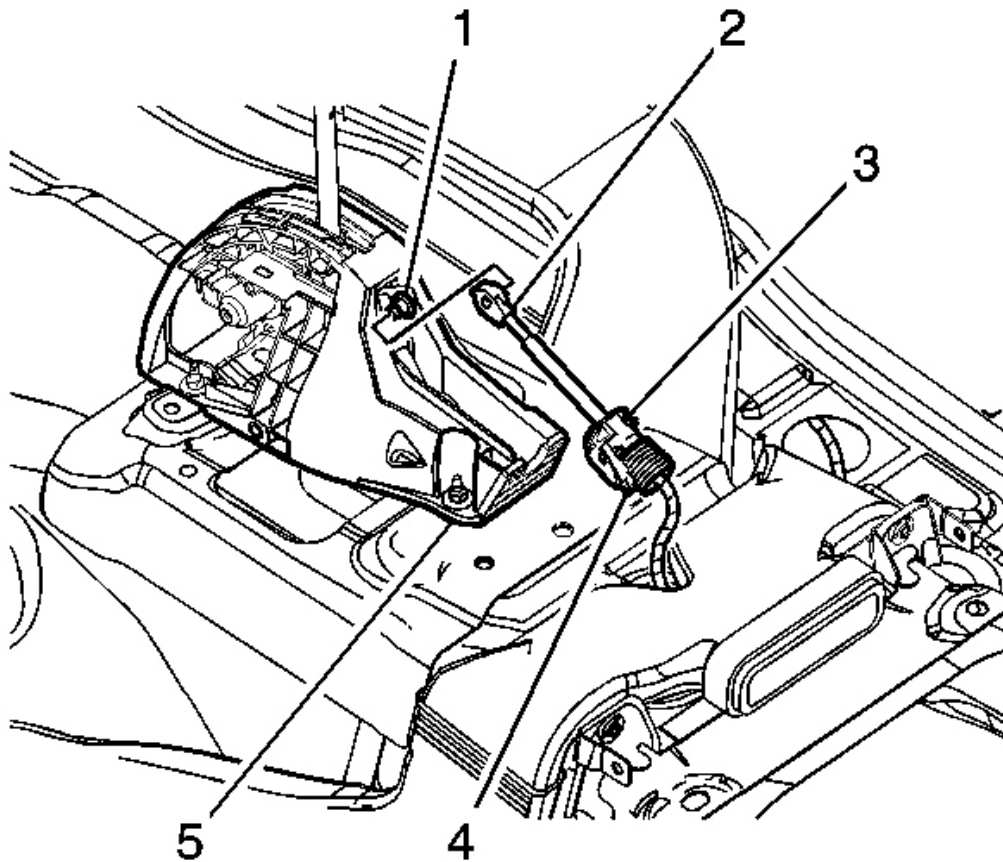

Fig. 32: View Of Transmission Range Selector Lever, Shift Control Assembly & Range Selector Cable
Courtesy of GENERAL MOTORS CORP.

11. Use a flat-bladed tool to separate the range selector cable (2) from the transmission range selector lever ball stud (1).
12. Release the cable retainer (4) from the shift control assembly (5).
13. Remove the range selector cable (3) from the vehicle.

Installation Procedure

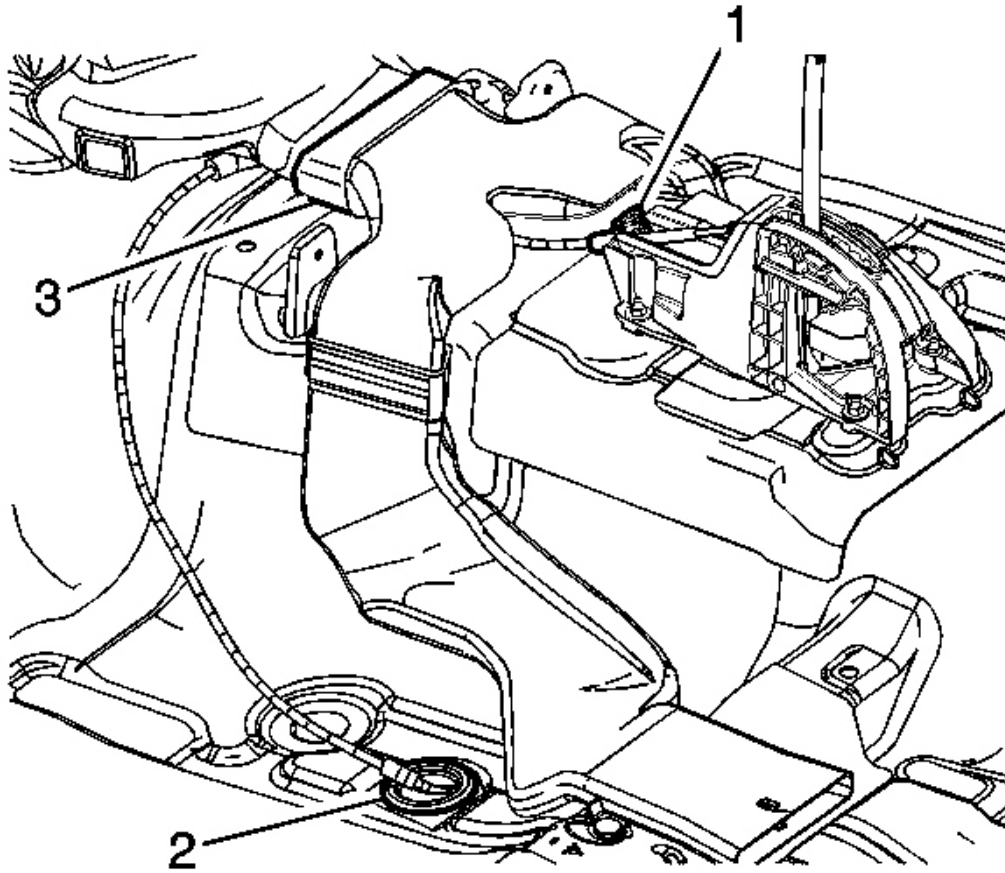

Fig. 33: Identifying Cable & Floor Panel Grommet
Courtesy of GENERAL MOTORS CORP.

1. Insert the range selector cable through the floor panel and seat the cable grommet (2).
2. Route the range selector cable under the heat duct (3).

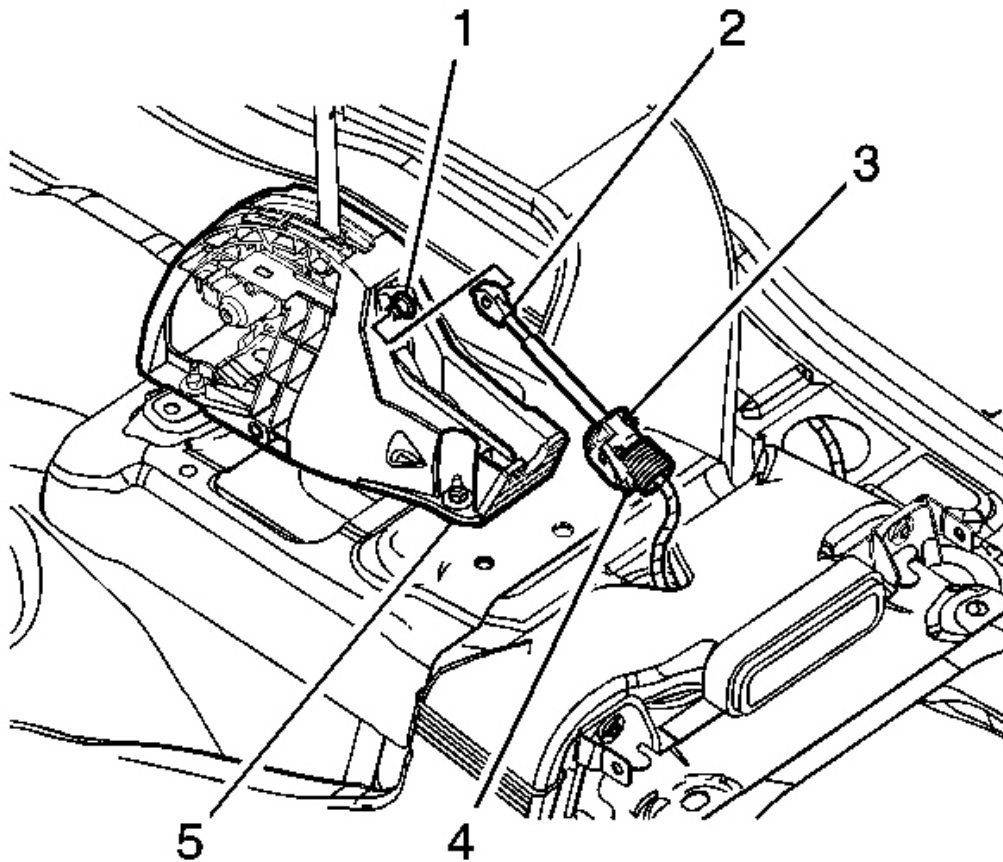

Fig. 34: View Of Transmission Range Selector Lever, Shift Control Assembly & Range Selector Cable
Courtesy of GENERAL MOTORS CORP.

3. Install the range selector cable (3) to the shift control assembly (5).
4. Ensure the cable retainer (4) is secured to the shift control assembly (5).
5. Push the range selector cable end (2) onto the range selector lever ball stud (1).
6. Reposition the drivers side carpet to the floor panel.
7. Inspect below the accelerator pedal for binding, to ensure full range of motion.
8. Install the cowl side trim panel. Refer to **Cowl Side Trim Panel Replacement** .
9. Raise and support the vehicle. Refer to **Lifting and Jacking the Vehicle** .

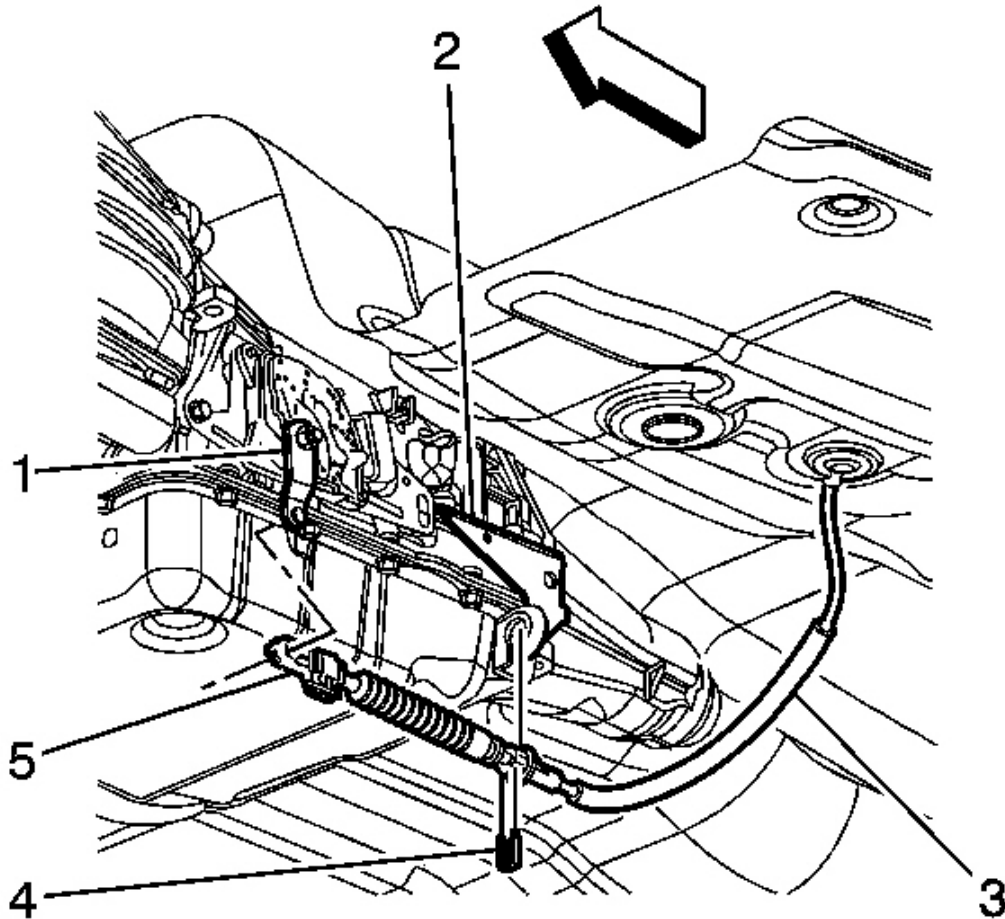

Fig. 35: View Of Range Selector Cable & Components
Courtesy of GENERAL MOTORS CORP.

10. Install the range selector cable (3) to the bracket (2).
11. Install the retainer (4) to the range selector cable (3).
12. Remove and discard the primary lock lockout pin if a new cable is being installed.
13. Install the range selector cable end (5) to the range selector lever (1).
14. Adjust the automatic transmission range selector cable. Refer to **Range Selector Lever Cable Adjustment**.
15. Lower the vehicle.

RANGE SELECTOR LEVER CABLE ADJUSTMENT**Adjustment Procedure**

1. Ensure that the range selector cable is not restricted.
2. Ensure that the column shift control is in the PARK position.
3. Raise and support the vehicle. Refer to **Lifting and Jacking the Vehicle** .

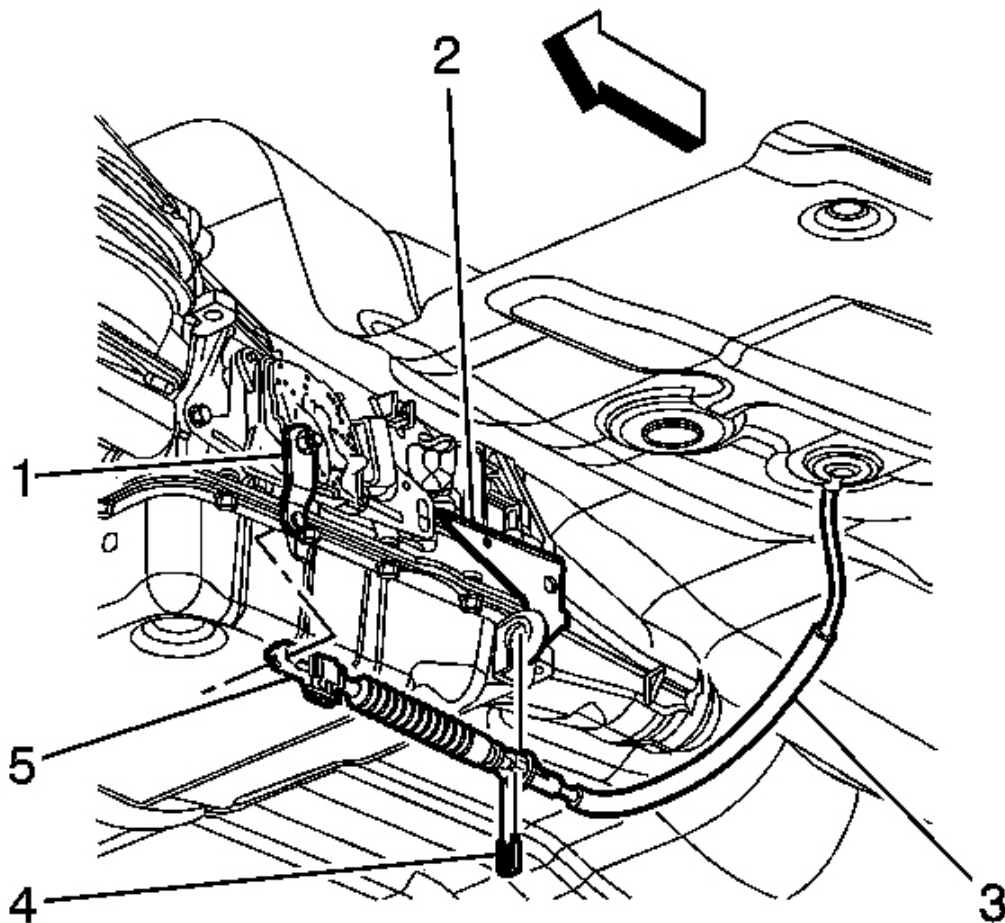

Fig. 36: View Of Range Selector Cable & Components
Courtesy of GENERAL MOTORS CORP.

IMPORTANT: Do not pull on the boot portion of the cable.

4. Complete the following in order to disconnect the range selector cable (3) from the transmission range selector lever ball stud.
 1. Insert a flat-bladed tool between the range selector cable end (5) and the range selector lever (1).
 2. Pry the range selector cable end (5) away from the range selector lever (1).
5. Ensure that the range selector lever is in the mechanical PARK position.

Rotate the range selector lever fully clockwise.

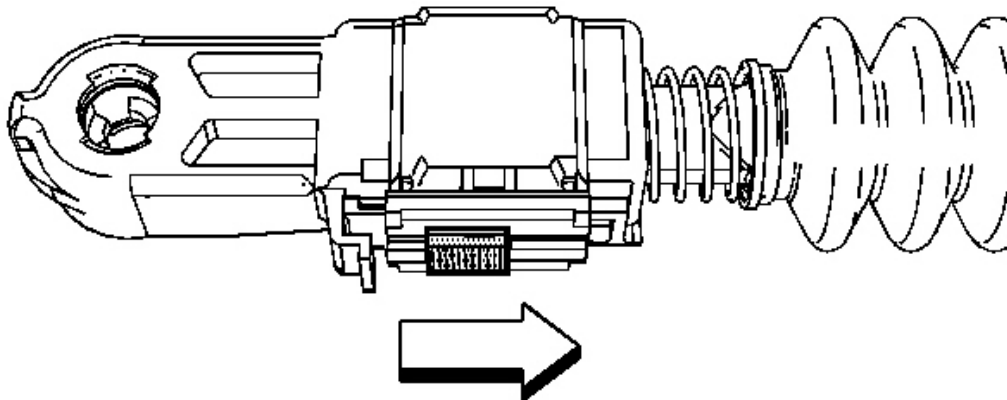

Fig. 37: Releasing Primary Lock
Courtesy of GENERAL MOTORS CORP.

6. Slide the secondary locking tab rearward to release the primary lock.

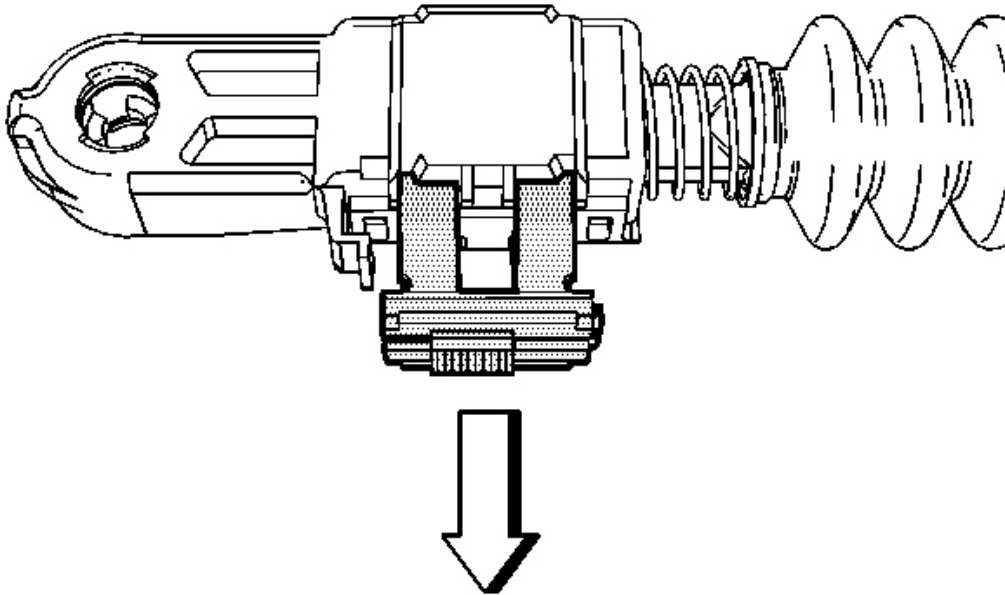

Fig. 38: Opening Primary Lock
Courtesy of GENERAL MOTORS CORP.

7. Open the primary lock to disengage.

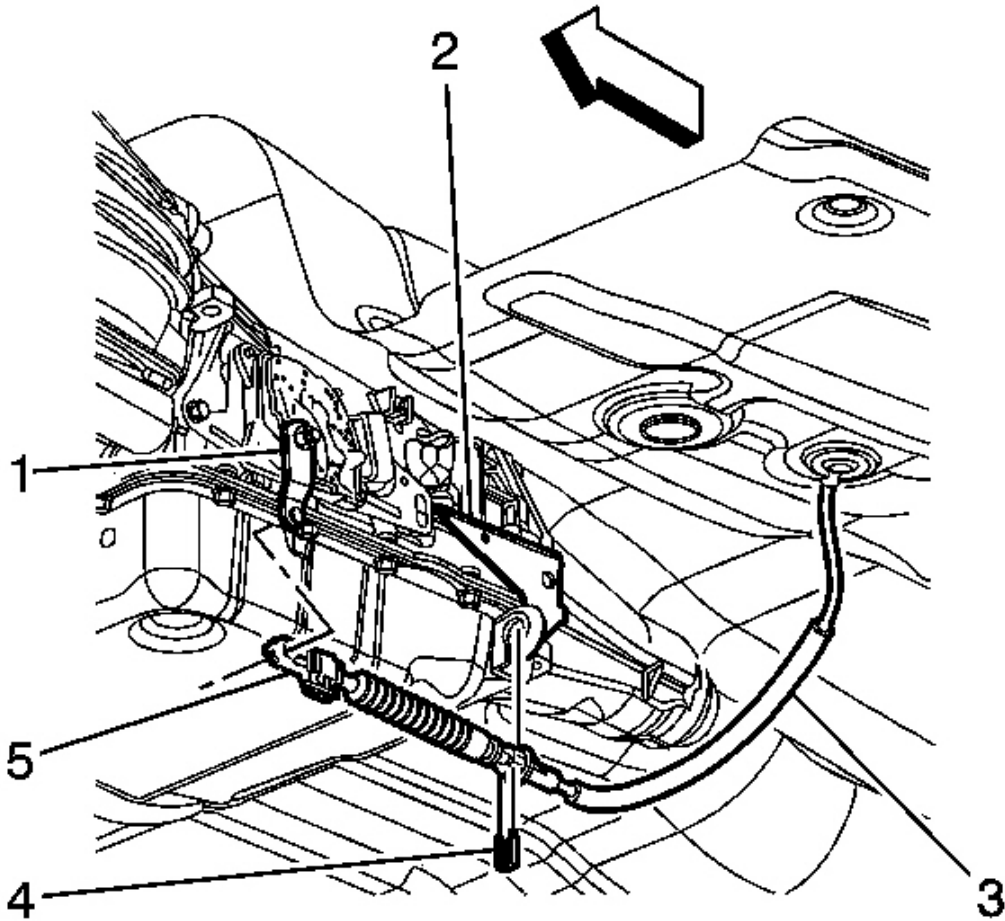

Fig. 39: View Of Range Selector Cable & Components
Courtesy of GENERAL MOTORS CORP.

8. Push the range selector cable end (5) onto the transmission range selector lever ball stud to secure.

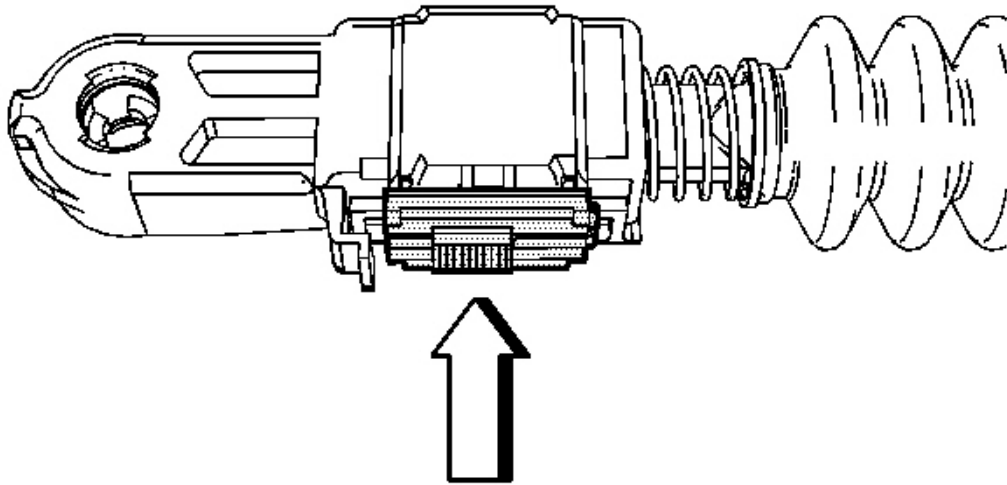

Fig. 40: Closing Primary Lock
Courtesy of GENERAL MOTORS CORP.

9. Close the primary lock to engage.

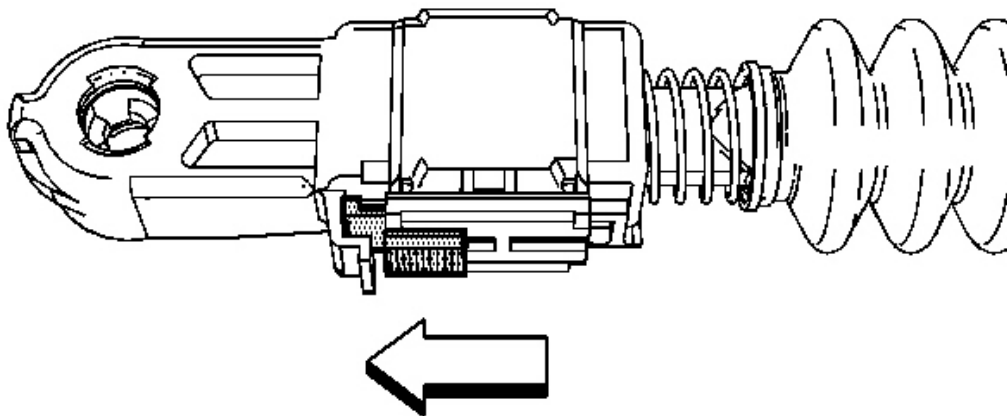

Fig. 41: Securing Primary Lock
Courtesy of GENERAL MOTORS CORP.

10. Slide the secondary locking tab forward to secure the primary lock.
11. Lower the vehicle.
12. Check the vehicle for proper operation.

AUTOMATIC TRANSMISSION RANGE SELECTOR LEVER CABLE BRACKET REPLACEMENT

Removal Procedure

1. Ensure the vehicle is in the PARK position.
2. Raise and support the vehicle. Refer to Lifting and Jacking the Vehicle .

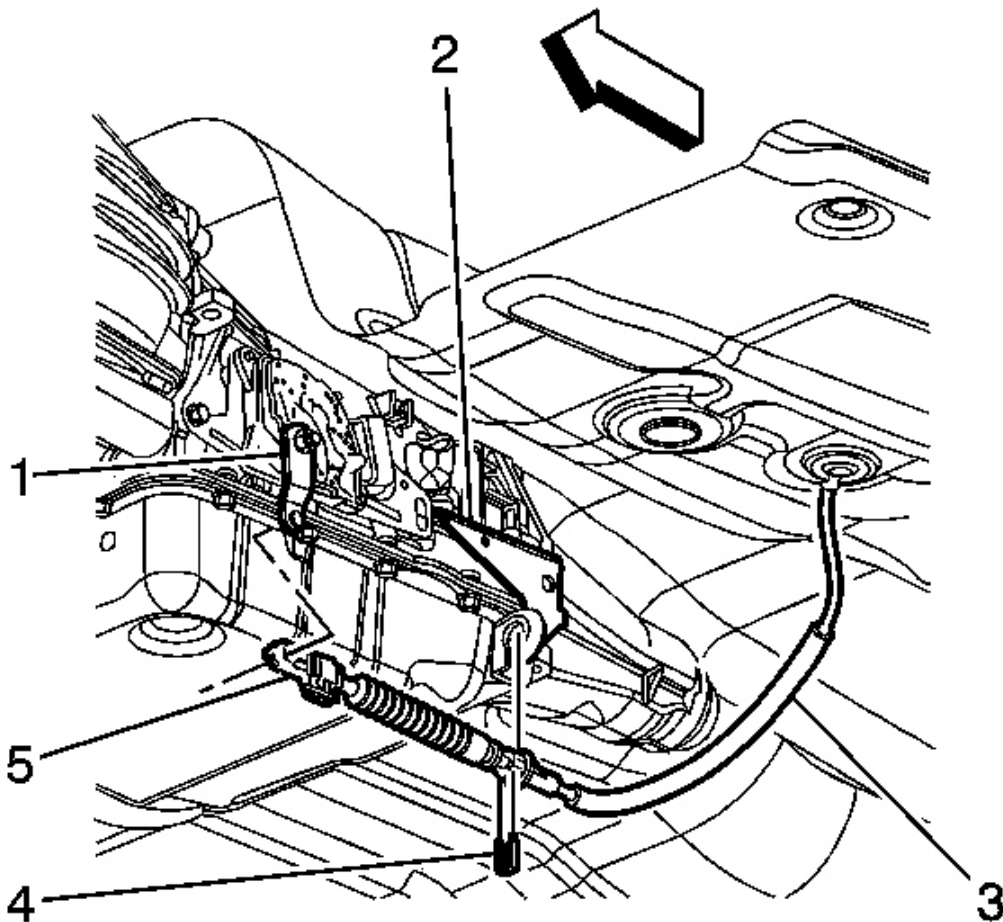

Fig. 42: View Of Range Selector Cable & Components
Courtesy of GENERAL MOTORS CORP.

IMPORTANT: Do not pull on the boot portion of the cable.

3. Complete the following in order to disconnect the range selector cable (3) from the transmission range selector lever ball stud.
 1. Insert a flat-bladed tool between the range selector cable end (5) and the range selector lever (1).
 2. Pry the range selector cable end (5) away from the range selector lever (1).
4. Remove the retainer (4) from the range selector cable (3).
5. Push the range selector cable locking tabs inward toward each other to release from the bracket (2).

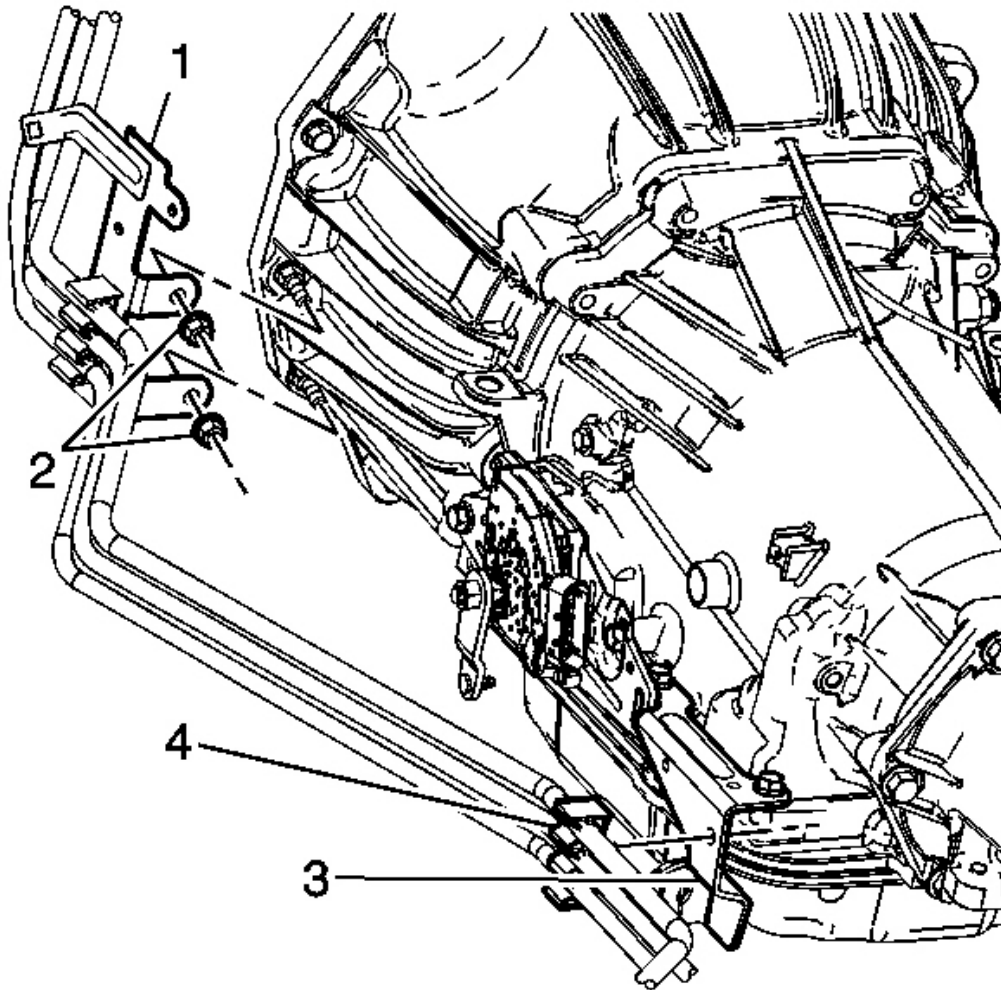

Fig. 43: View Of Fuel Hose/Pipe Bracket & Nuts (M30)
Courtesy of GENERAL MOTORS CORP.

6. Disconnect the fuel hose/pipe retainer (4) from the range selector cable bracket (3).

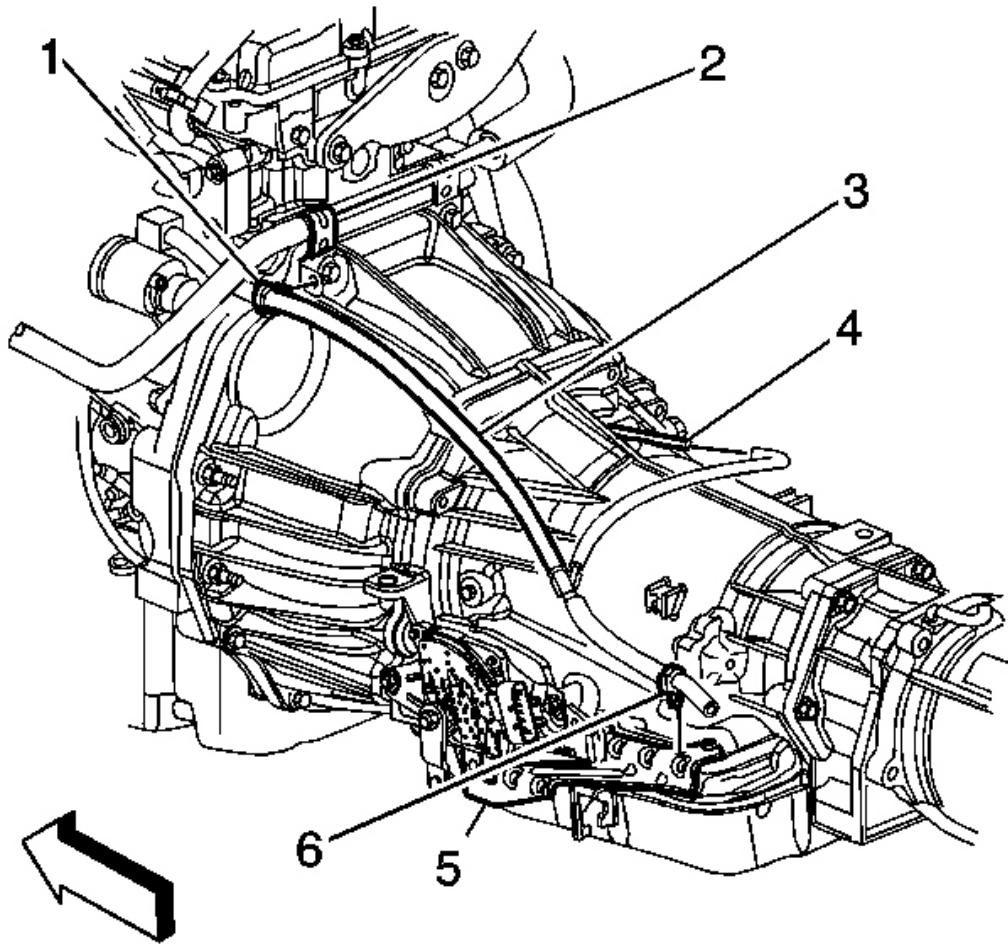

Fig. 44: View Of Transmission Vent Hose & Retainers
Courtesy of GENERAL MOTORS CORP.

7. Disconnect the transmission vent hose retainer (6) from the range selector cable bracket.

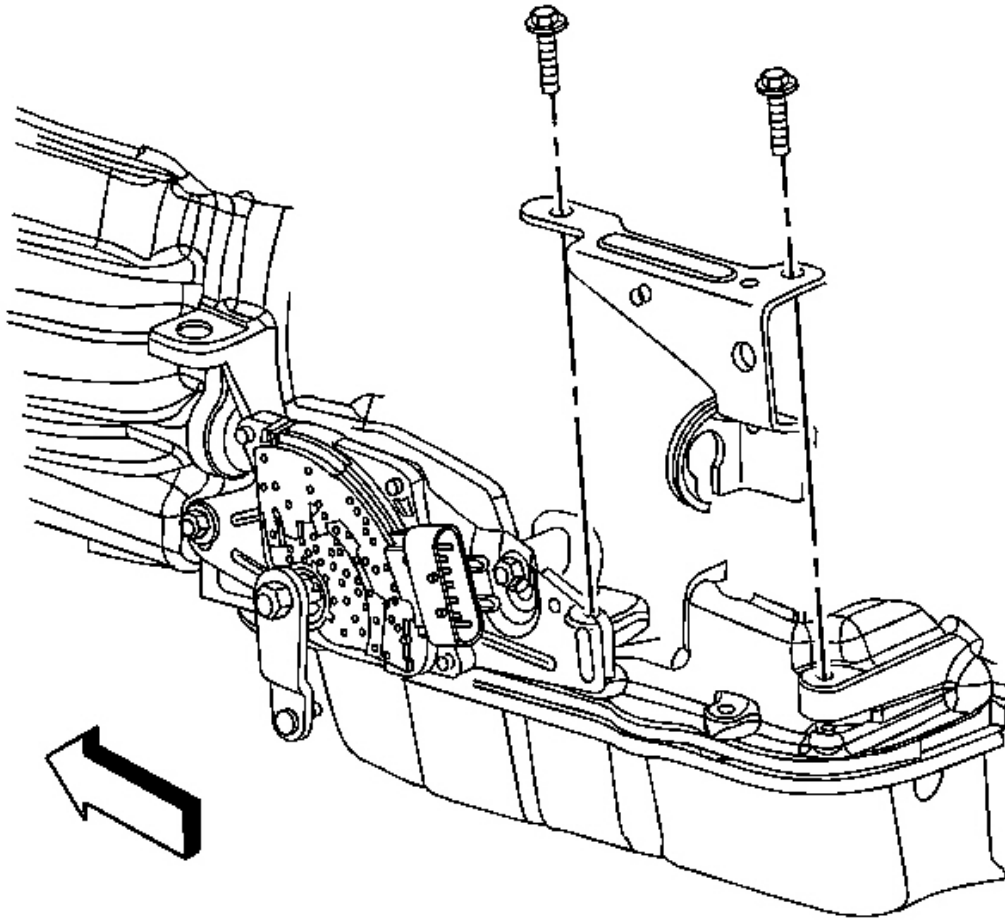

Fig. 45: View Of Transmission Range Selector Cable Bracket
Courtesy of GENERAL MOTORS CORP.

8. Remove the bolts securing the transmission range selector cable bracket to the transmission.
9. Remove the transmission range selector cable bracket from the transmission.

Installation Procedure

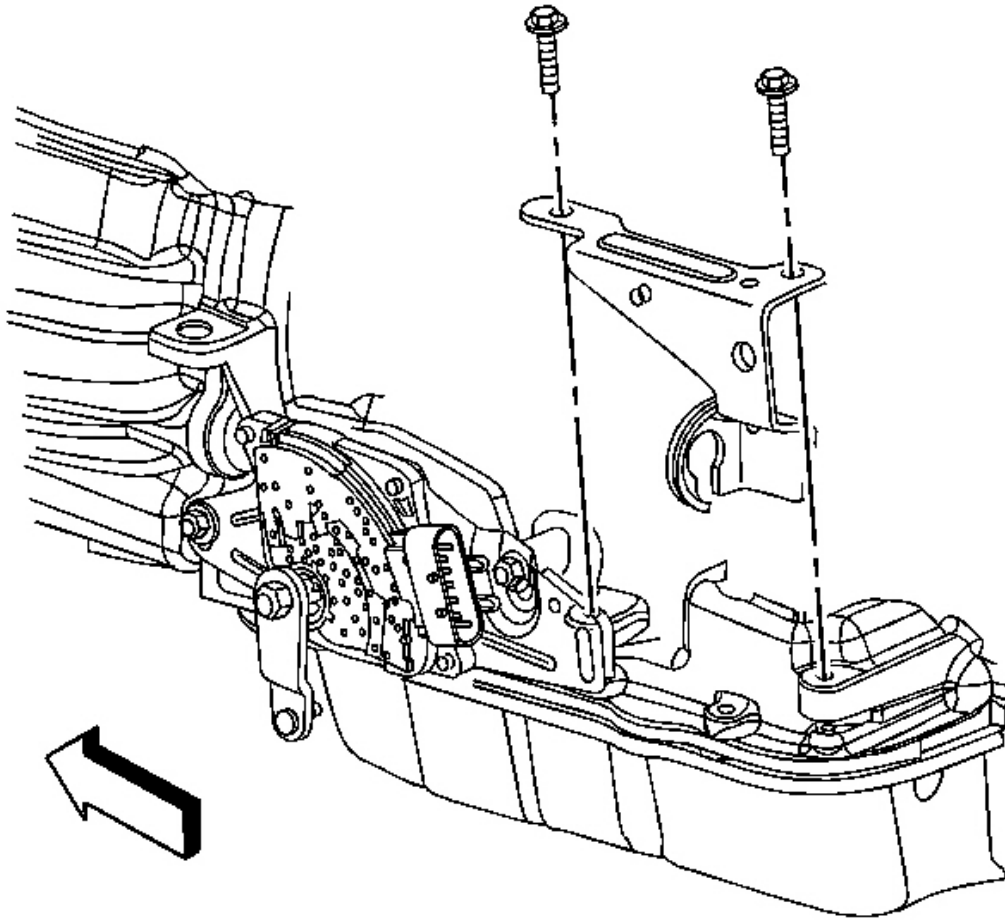

Fig. 46: View Of Transmission Range Selector Cable Bracket
Courtesy of GENERAL MOTORS CORP.

1. Position the transmission range selector cable bracket to the transmission.

NOTE: Refer to Fastener Notice .

2. Install the transmission range selector cable bracket bolts.

Tighten: Tighten the transmission range selector cable bracket bolts to 25 N.m (18 lb ft).

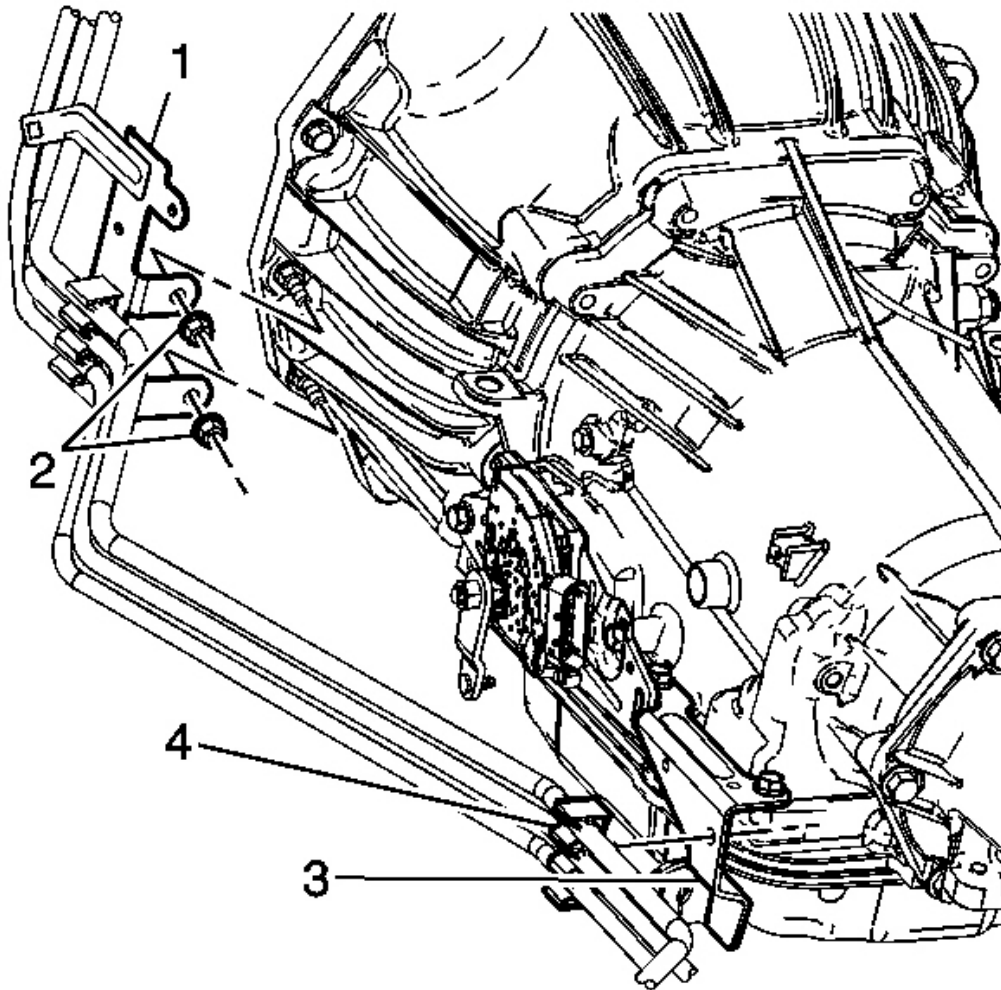

Fig. 47: View Of Fuel Hose/Pipe Bracket & Nuts (M30)
Courtesy of GENERAL MOTORS CORP.

3. Connect the fuel hose/pipe retainer (4) to the range selector cable bracket (3).

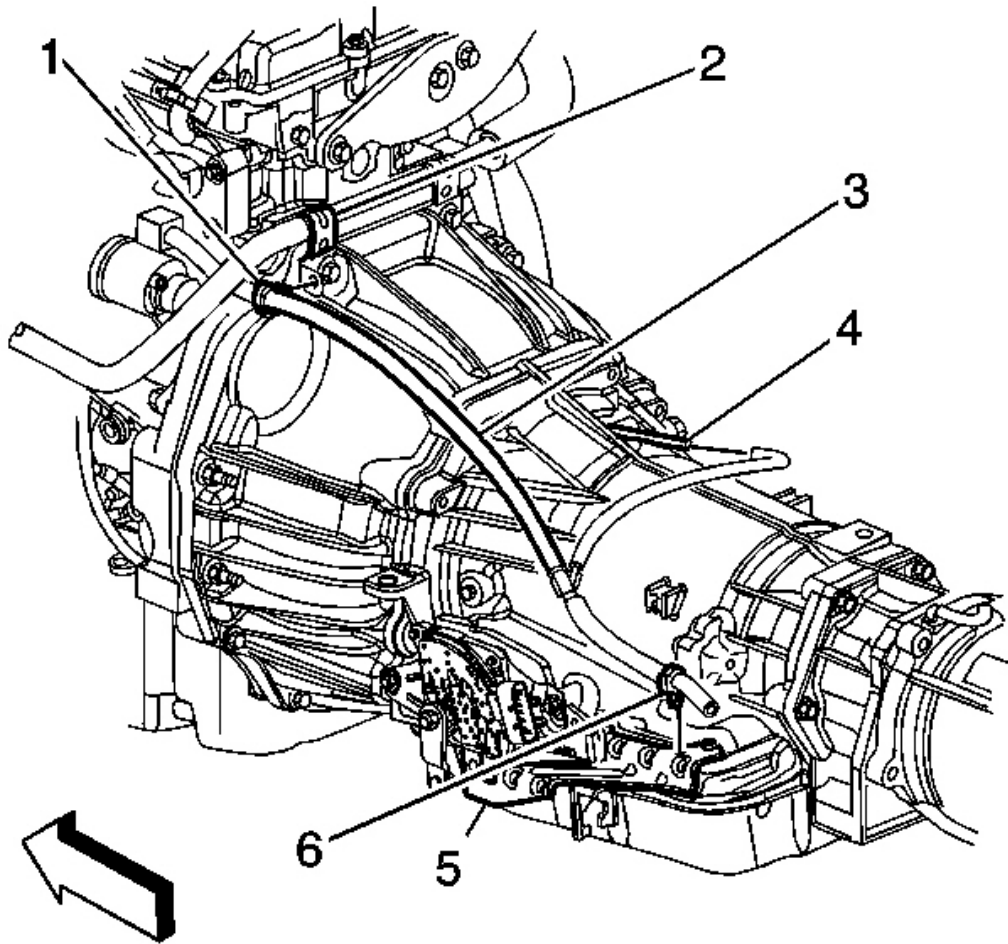

Fig. 48: View Of Transmission Vent Hose & Retainers
Courtesy of GENERAL MOTORS CORP.

4. Connect the transmission vent hose retainer (6) to the range selector cable bracket.

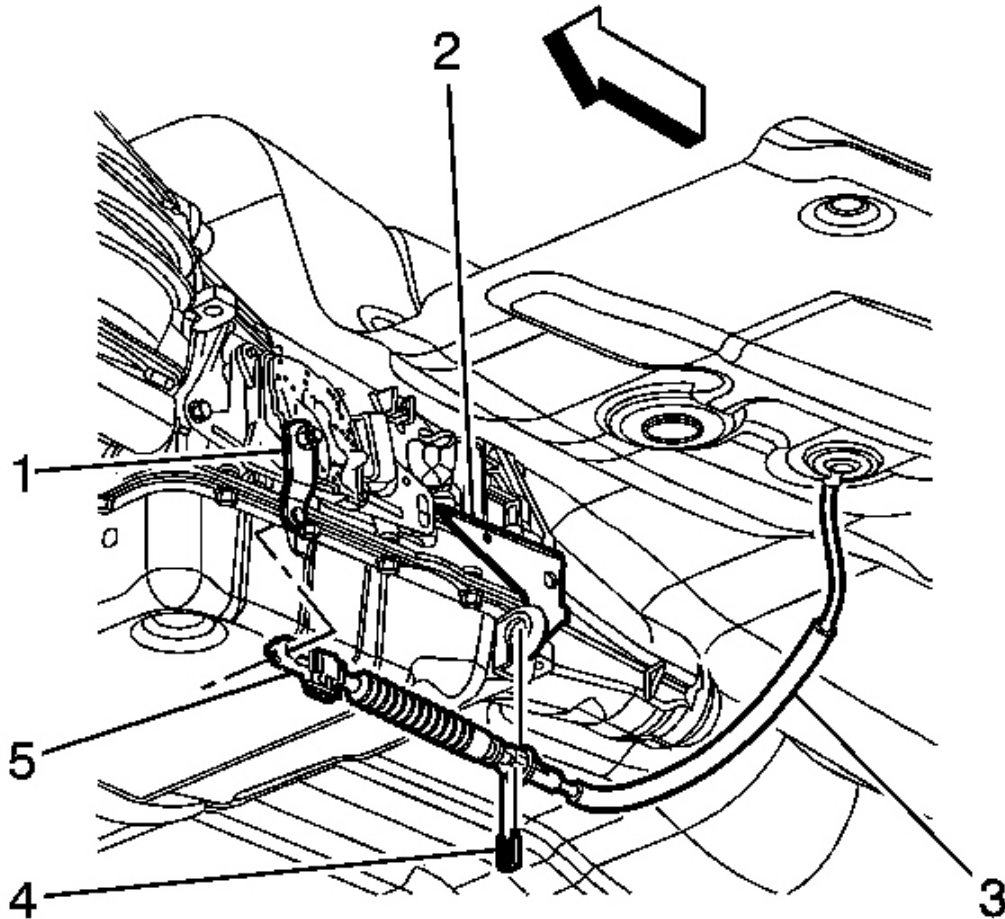

Fig. 49: View Of Range Selector Cable & Components
 Courtesy of GENERAL MOTORS CORP.

5. Install the range selector cable (3) to the bracket (2).
6. Install the retainer (4) to the range selector cable (3).
7. Adjust the automatic transmission range selector cable. Refer to **Range Selector Lever Cable Adjustment**.
8. Lower the vehicle.

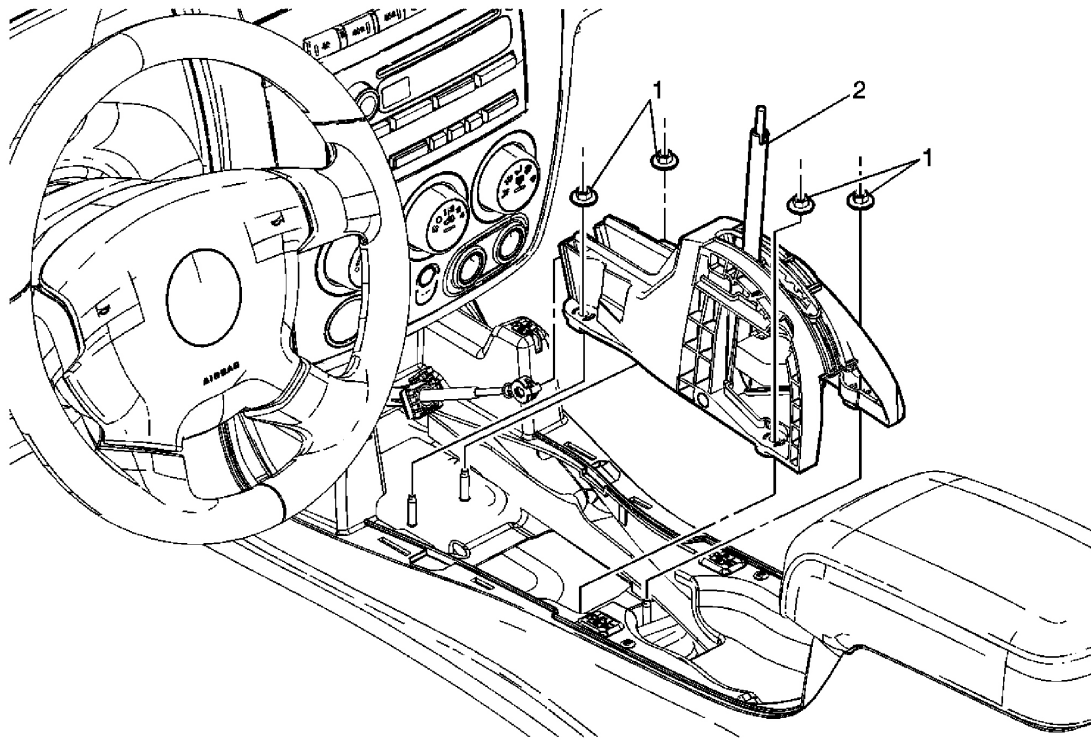

Fig. 50: Floor Shift Control Replacement
 Courtesy of GENERAL MOTORS CORP.

Automatic Transmission Control Replacement

Callout	Component Name
---------	----------------

NOTE:

Refer to Fastener Notice .

Fastener Tightening Specifications: Refer to Fastener Tightening Specifications .

Preliminary Procedures

1. Remove the floor shift control knob. Refer to Floor Shift Control Knob Replacement.
2. Remove the console upper trim plate. Refer to Front Floor Upper Console Trim Plate Replacement (LHD w/Automatic Transmission) or Front Floor Upper Console Trim Plate Replacement (LHD w/Manual Transmission) or Front Floor Upper Console Trim Plate Replacement (RHD w/Automatic Transmission) or Front Floor Upper Console Trim Plate Replacement (RHD w/Manual Transmission) .

2007 Hummer H3

2007 TRANSMISSION Automatic Transmission - 4L60-E/4L65-E/4L70-E - H3

3. Disconnect the transmission range selector cable from the floor shift control. Refer to **Automatic Transmission Range Selector Lever Cable Replacement**.

1	Floor Shift Control Bolts (Qty: 4) Tighten: 20 N.m (15 lb ft)
2	Floor Shift Control

PARK/NEUTRAL BACKUP SWITCH REPLACEMENT

Tools Required

J 41364-A Park Neutral Switch Aligner

Removal Procedure

1. Apply the parking brake.
2. Shift the transmission into NEUTRAL.
3. Raise and support the vehicle. Refer to **Lifting and Jacking the Vehicle** .

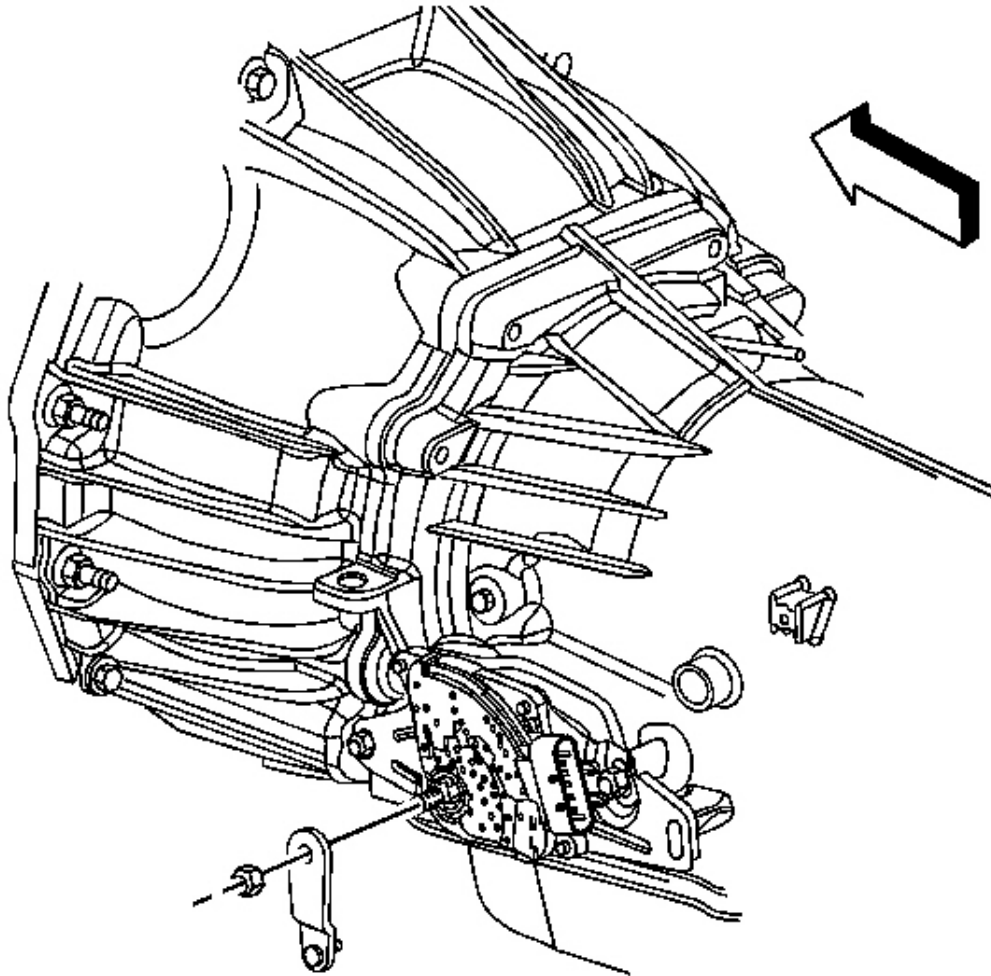

Fig. 51: View Of Transmission Control Lever
Courtesy of GENERAL MOTORS CORP.

4. Remove the nut securing the transmission control lever to the manual shaft.
5. Remove the transmission control lever from the manual shaft.

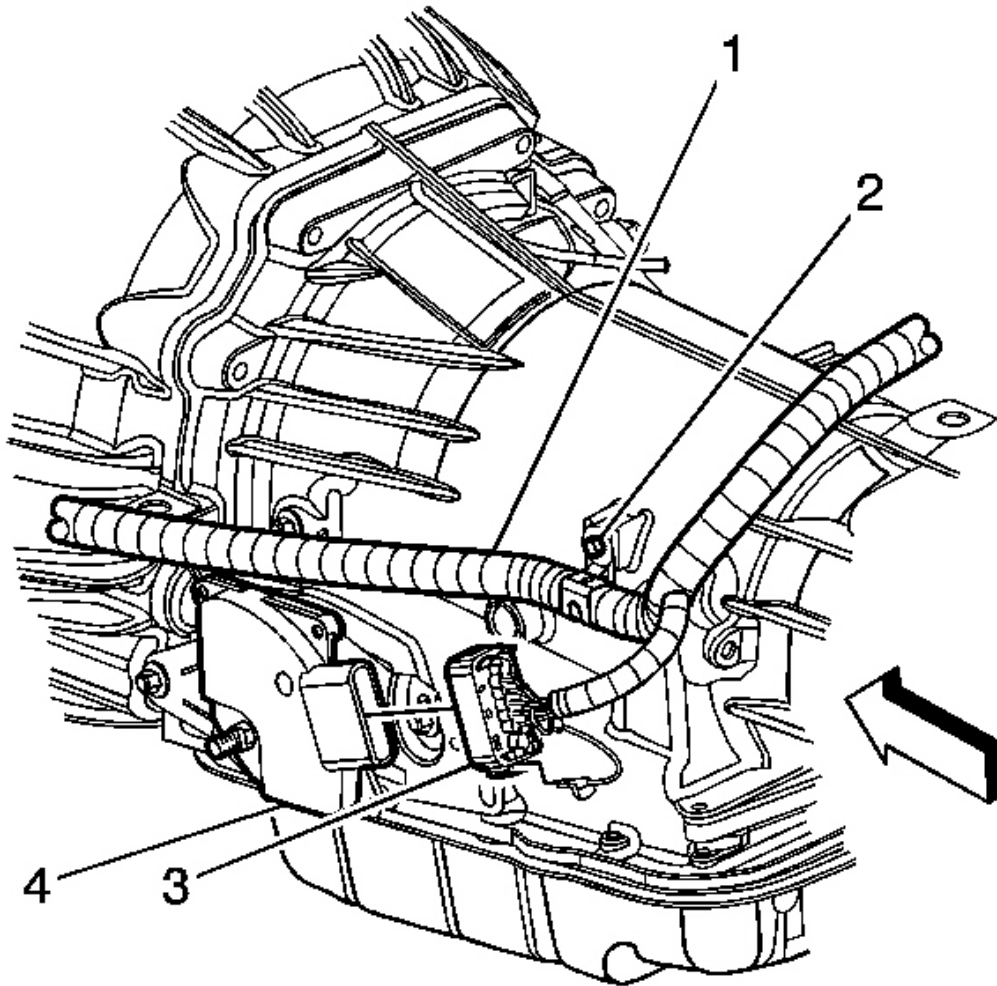

Fig. 52: View Of Park/Neutral Back Up Switch Electrical Connector
Courtesy of GENERAL MOTORS CORP.

6. Disconnect the electrical connector (3) from the switch (4).

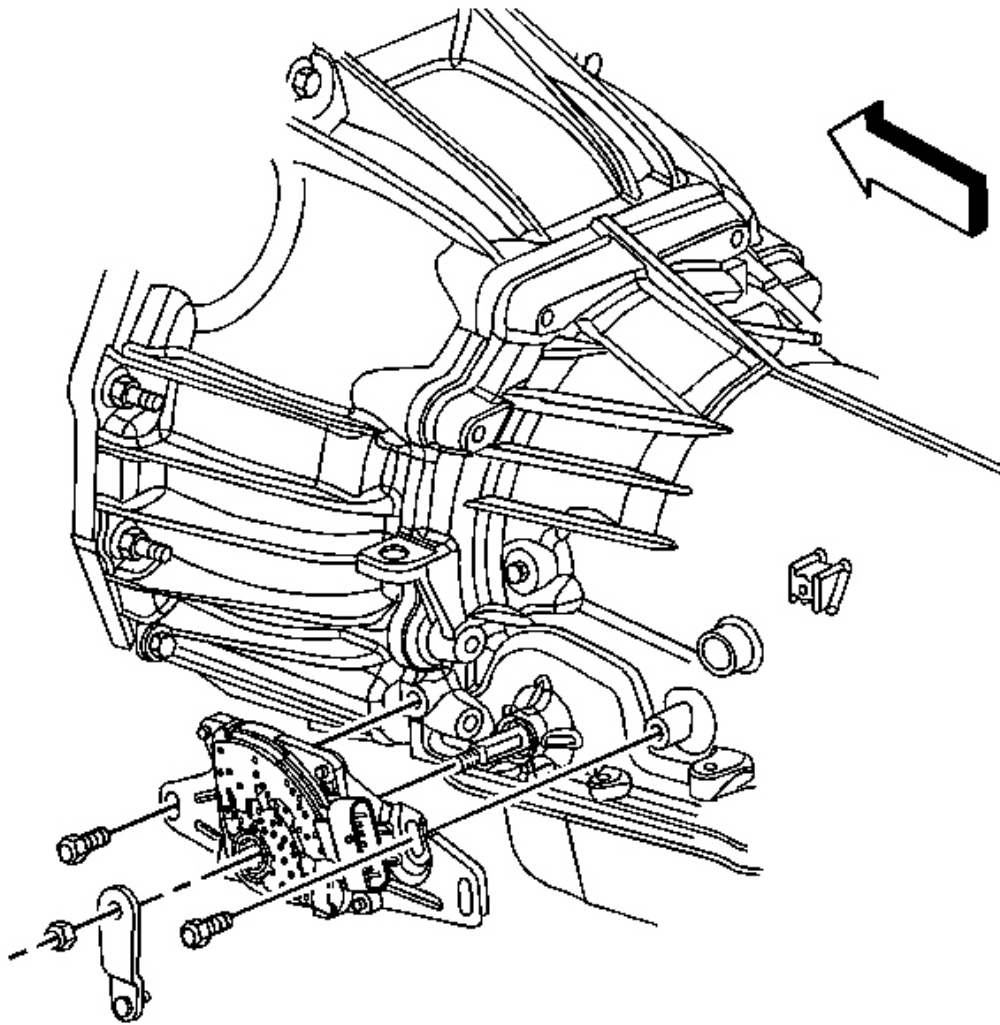

Fig. 53: View Of Park/Neutral Back Up Switch
Courtesy of GENERAL MOTORS CORP.

7. Remove the bolts securing the park/neutral back up switch to the transmission.

IMPORTANT: If the switch does not slide off the manual shaft, the outer edge of the manual shift shaft may need to be filed to remove any burrs.

8. Remove the park/neutral back up switch from the manual shaft.

Installation Procedure

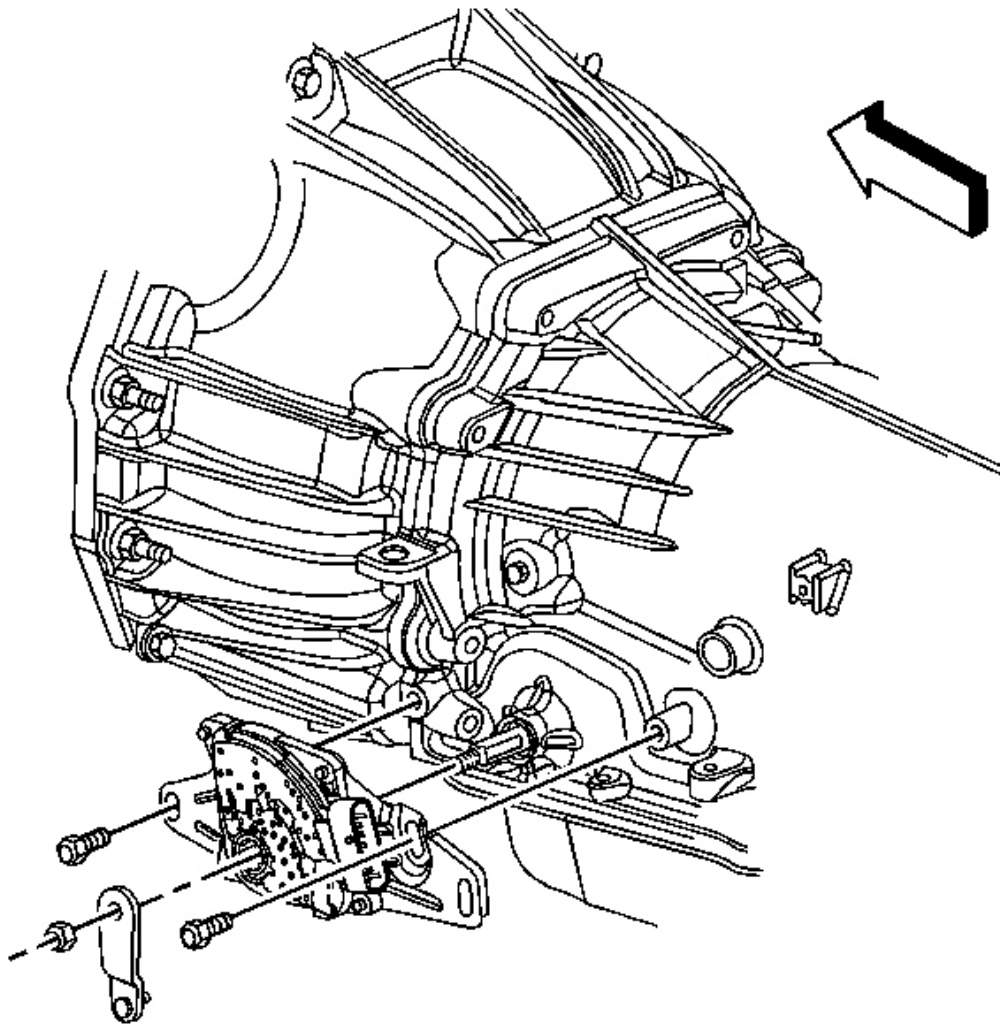

Fig. 54: View Of Park/Neutral Back Up Switch
Courtesy of GENERAL MOTORS CORP.

1. Install the park/neutral back up switch to the transmission manual shaft by aligning the switch hub flats with the manual shaft flats.
2. Slide the switch onto the transmission manual shaft until the switch mounting bracket

contacts the mounting bosses on the transmission.

IMPORTANT: If a new switch is being installed, the switch will come with a positive assurance bracket. The positive assurance bracket aligns the new switch in the proper position for installation and the use of the J 41364-A will not be necessary.

3. Loosely install the 2 park/neutral back up switch bolts.

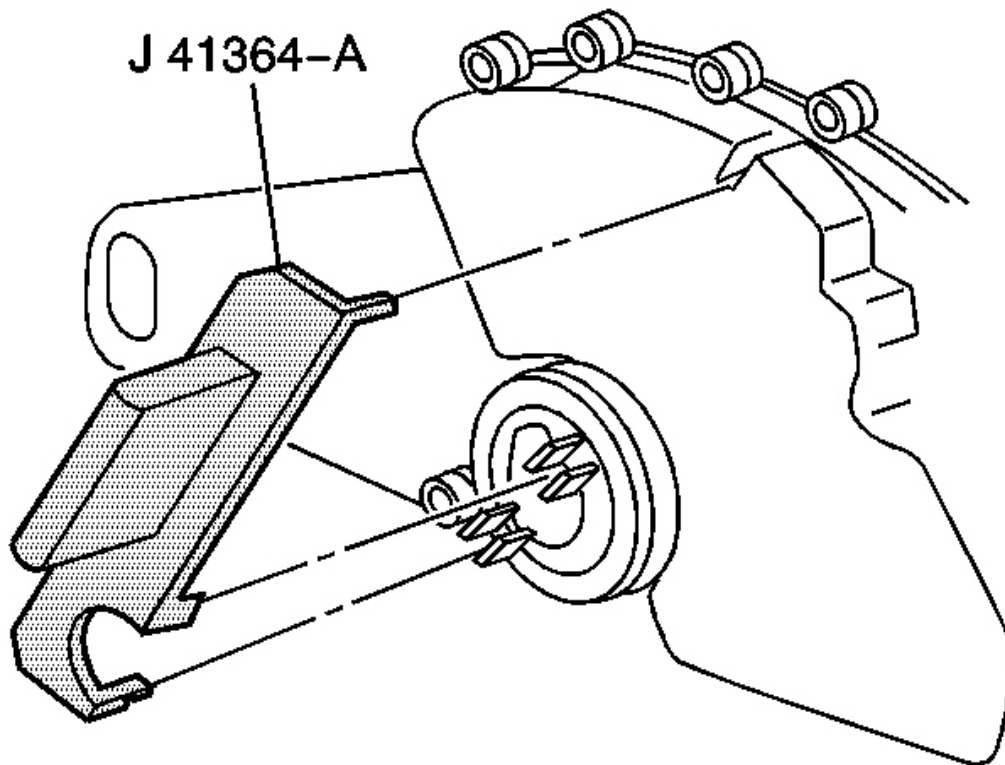

Fig. 55: Positioning The J 41364-A Onto The PNP Switch
Courtesy of GENERAL MOTORS CORP.

4. Position the J 41364-A onto the park/neutral back up switch. Ensure that the 2 slots on the switch where the manual shaft is inserted are lined up with the lower 2 tabs on the tool.

NOTE: Refer to Fastener Notice .

5. Rotate the switch until the upper locator pin on the tool is lined up with the slot on the top of the switch.

Tighten: Tighten the park/neutral back up switch bolts 27 N.m (20 lb ft).

6. Remove the **J 41364-A** from the switch. If installing a new switch, remove the positive assurance bracket at this time.

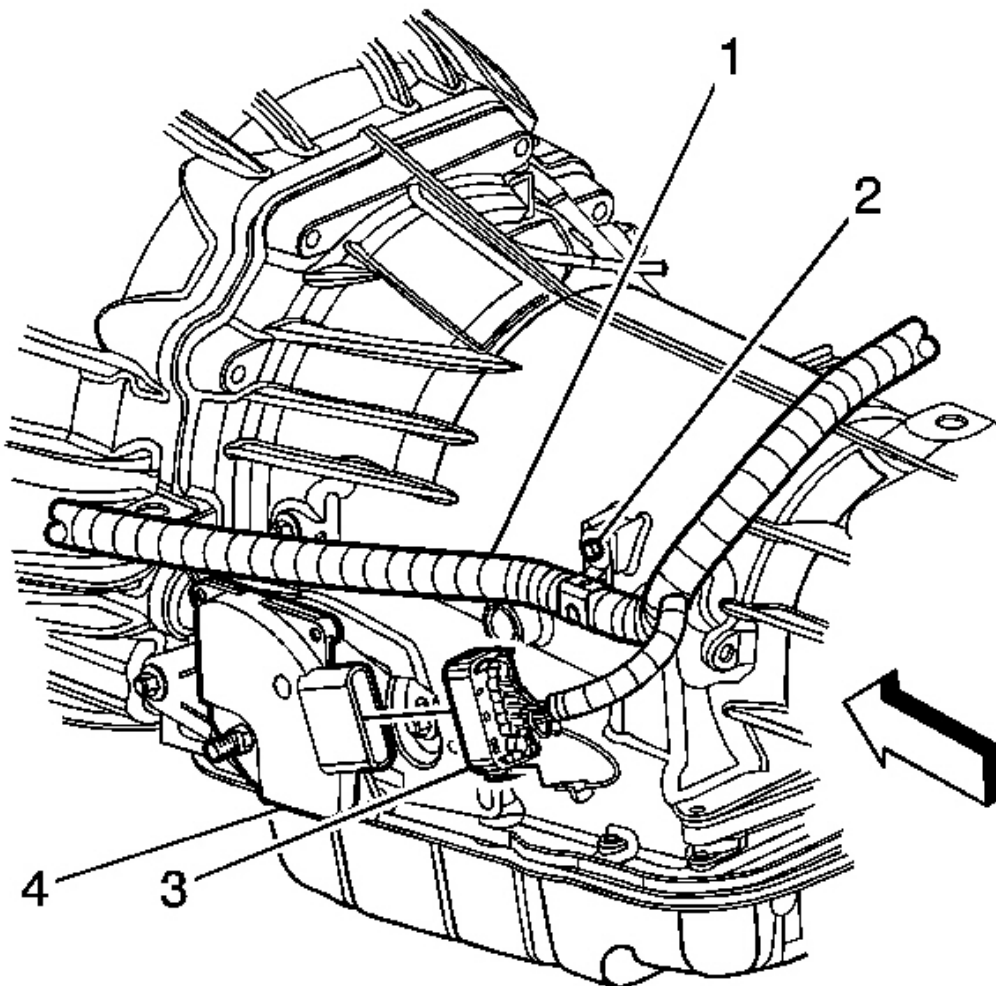

Fig. 56: View Of Park/Neutral Back Up Switch Electrical Connector
Courtesy of GENERAL MOTORS CORP.

7. Connect the electrical connector (3) to the switch (4).

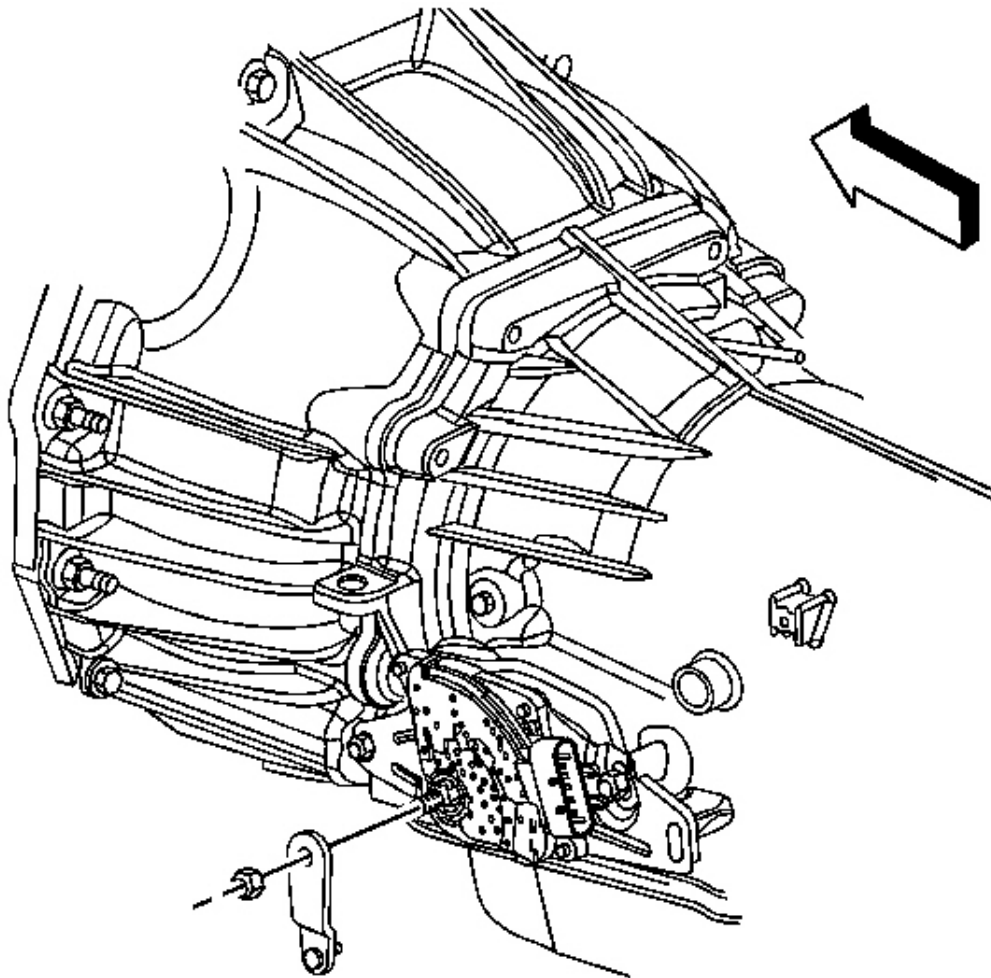

Fig. 57: View Of Transmission Control Lever
Courtesy of GENERAL MOTORS CORP.

8. Install the transmission control lever to the manual shaft with the nut.

Tighten: Tighten the control lever nut to 20 N.m (15 lb ft).

9. Lower the vehicle.

10. Adjust the automatic transmission range selector cable. Refer to **Range Selector Lever Cable Adjustment**.
11. Check the switch for proper operation. The engine must start in the P (PARK) or N (NEUTRAL) positions only. If proper operation of the switch can not be obtained, replace the switch.

PARK/NEUTRAL BACKUP SWITCH ADJUSTMENT

- IMPORTANT:**
- The following procedure is for vehicles that have not had the switch removed or replaced. If the switch has been removed or replaced, refer to **Park/Neutral Backup Switch Replacement** for the proper adjustment procedure.
 - Apply the parking brake.
 - The engine must start in the P (PARK) or N (NEUTRAL) positions only.
 - Check the switch for proper operation. If adjustment is required, proceed as follows:

1. Place the transmission range selector in the N (NEUTRAL) position.
2. With an assistant in the drivers seat, raise and support the vehicle. Refer to **Lifting and Jacking the Vehicle** .
3. Loosen the park/neutral position switch mounting bolts.
4. With the vehicle in the N (NEUTRAL) position, rotate the switch while the assistant attempts to start the engine.
5. Following a successful start, turn the engine OFF.

NOTE: Refer to **Fastener Notice** .

6. Tighten the bolts securing the park/neutral back up switch to the transmission.

Tighten: Tighten the park/neutral back up switch bolts to 27 N.m (20 lb ft).

7. Lower the vehicle.
8. Check the switch for proper operation. The engine must start in the P (PARK) or N (NEUTRAL) positions only.
9. Replace the park/neutral position switch if proper operation can not be achieved. Refer to **Park/Neutral Backup Switch Replacement**.

AUTOMATIC TRANSMISSION FLUID AND FILTER REPLACEMENT**Removal Procedure**

1. Raise and support the vehicle. Refer to Lifting and Jacking the Vehicle .

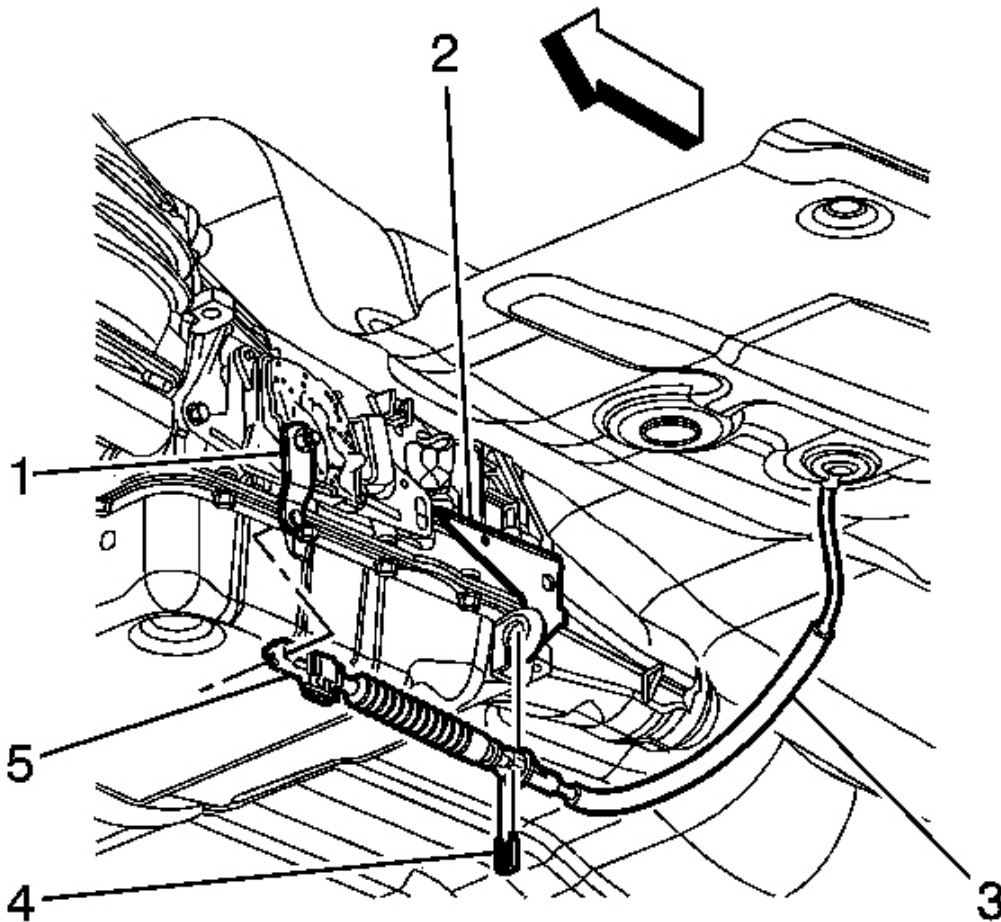

Fig. 58: View Of Range Selector Cable & Components
Courtesy of GENERAL MOTORS CORP.

IMPORTANT: Do not pull on the boot portion of the cable.

2. Complete the following in order to disconnect the range selector cable (3) from the

transmission range selector lever ball stud:

1. Insert a flat-bladed tool between the range selector cable end (5) and the range selector lever (1).
2. Pry the range selector cable end (5) away from the range selector lever (1).

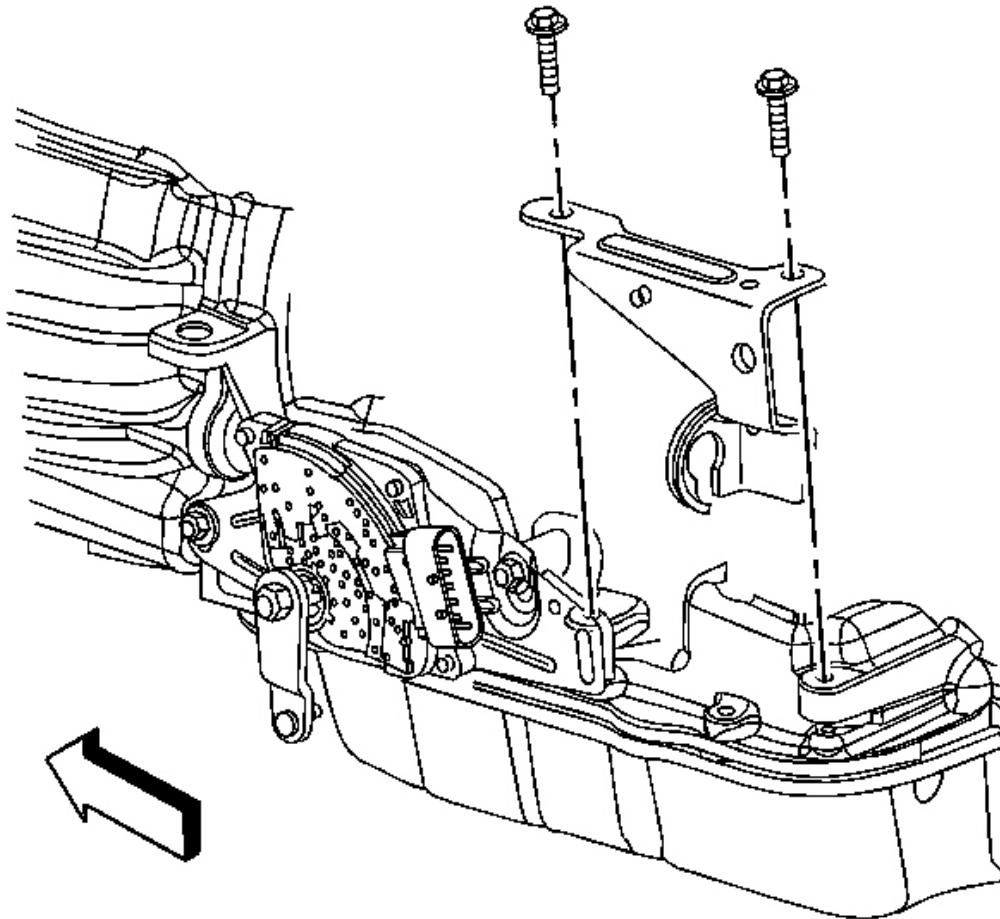

Fig. 59: View Of Transmission Range Selector Cable Bracket
Courtesy of GENERAL MOTORS CORP.

3. Remove the bolts securing the transmission range selector cable bracket to the transmission.
4. Position the transmission range selector cable bracket aside for clearance while lowering the pan.

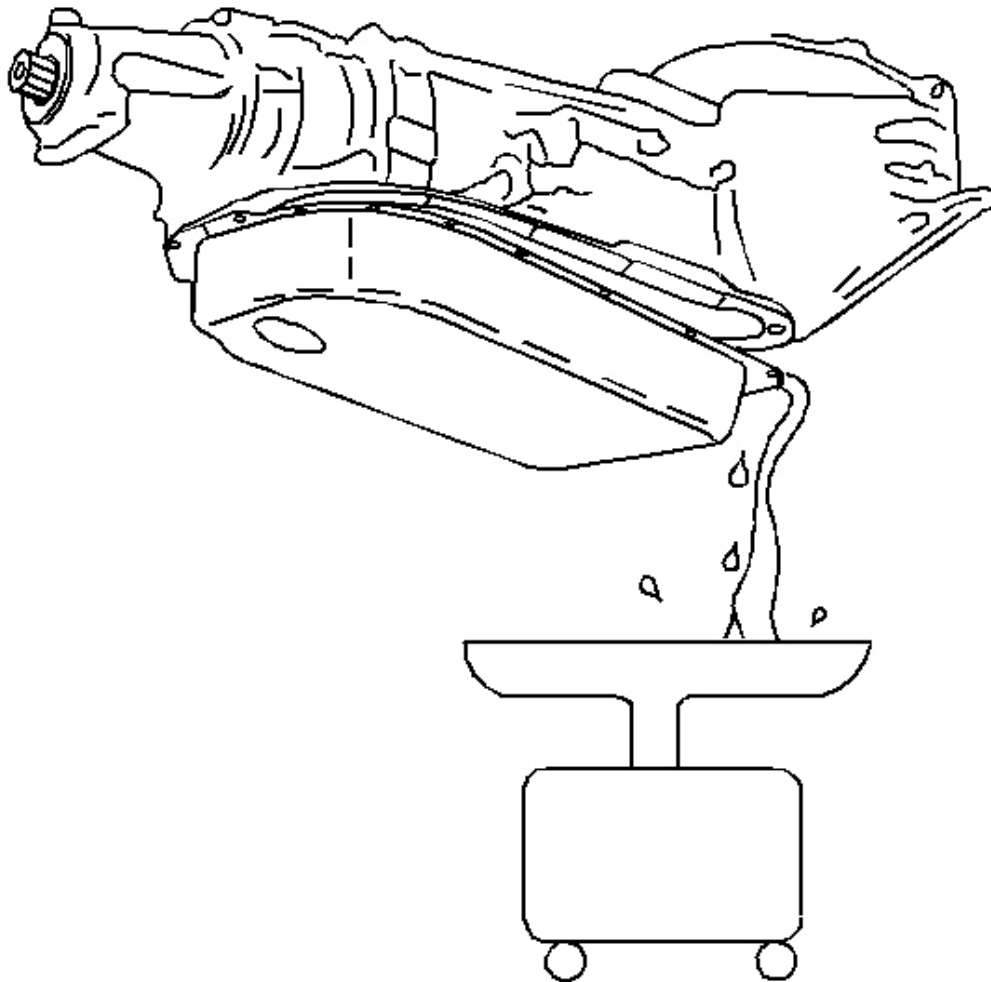

Fig. 60: Draining Transmission
Courtesy of GENERAL MOTORS CORP.

5. Position an appropriate container under the transmission oil pan.
6. Remove the oil pan bolts from the front and sides of the pan only.
7. Loosen the rear oil pan bolts approximately 4 turns.
8. Lightly tap the oil pan with a rubber mallet in order to loosen the pan, allow the transmission fluid to drain into the container.

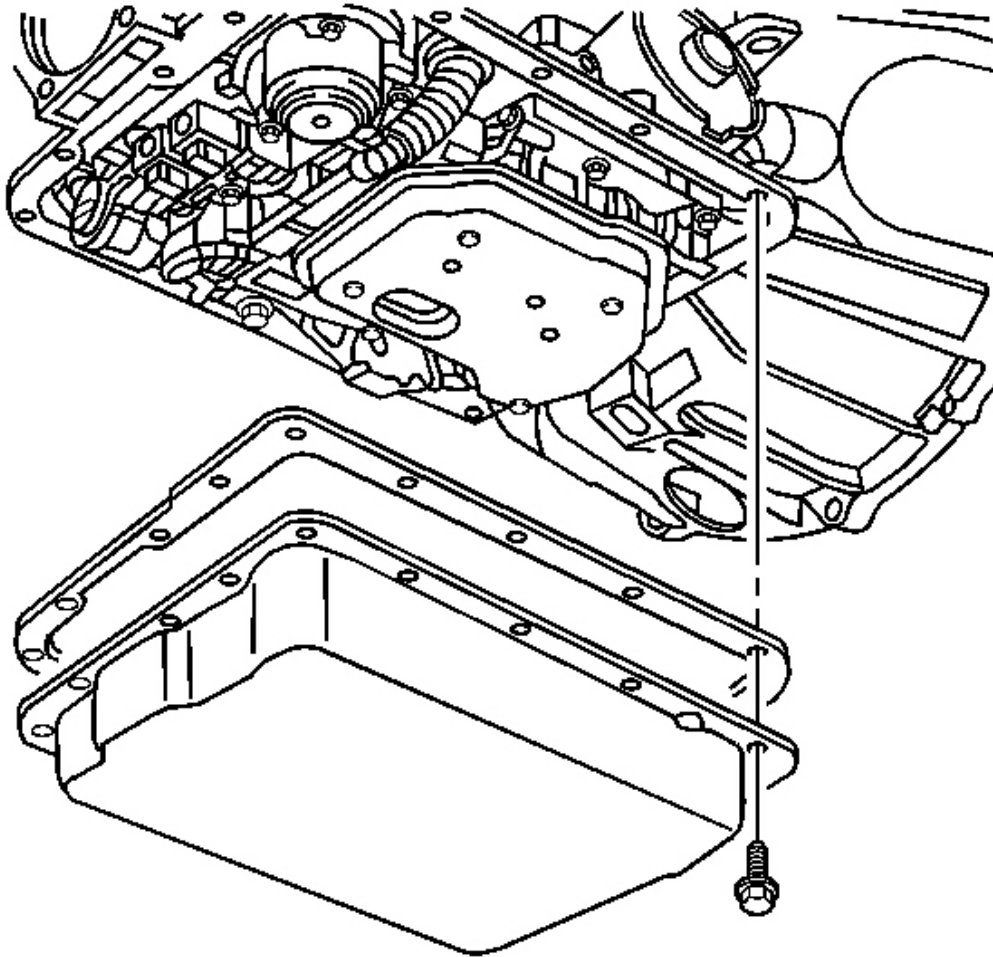

Fig. 61: View Of Oil Pan & Gasket
Courtesy of GENERAL MOTORS CORP.

9. Remove the remaining oil pan bolts.
10. Remove the oil pan and the gasket.

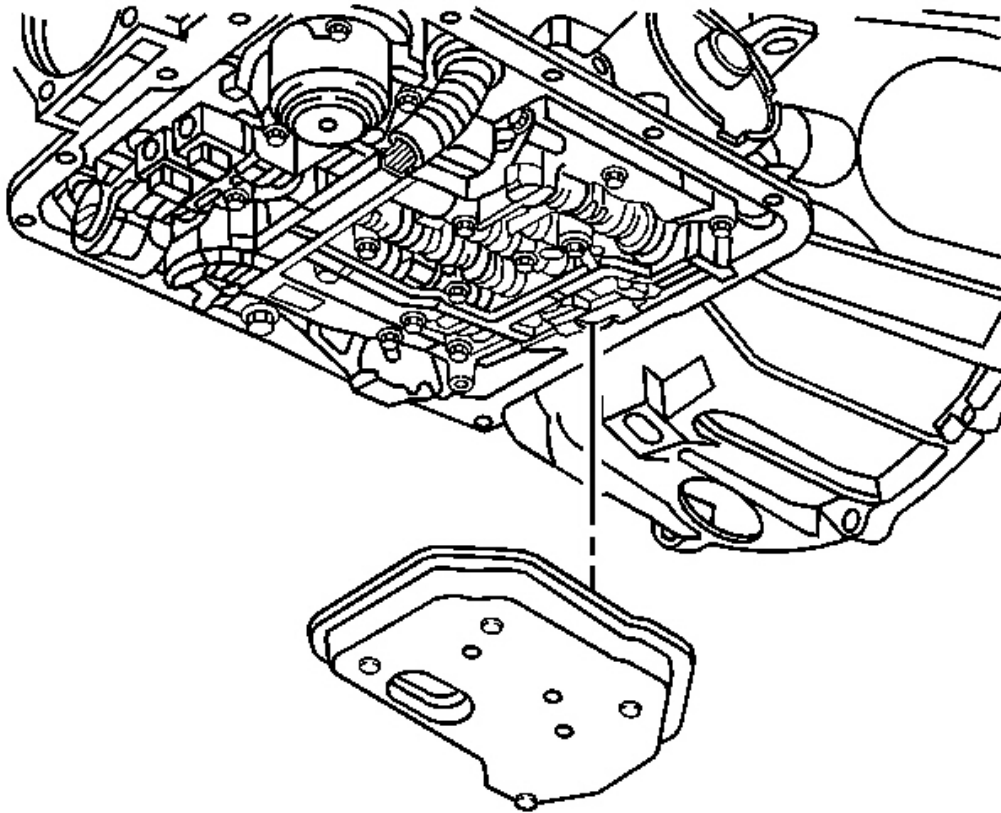

Fig. 62: View Of Filter

Courtesy of GENERAL MOTORS CORP.

11. Grasp firmly while pulling down with a twisting motion in order to remove the filter.

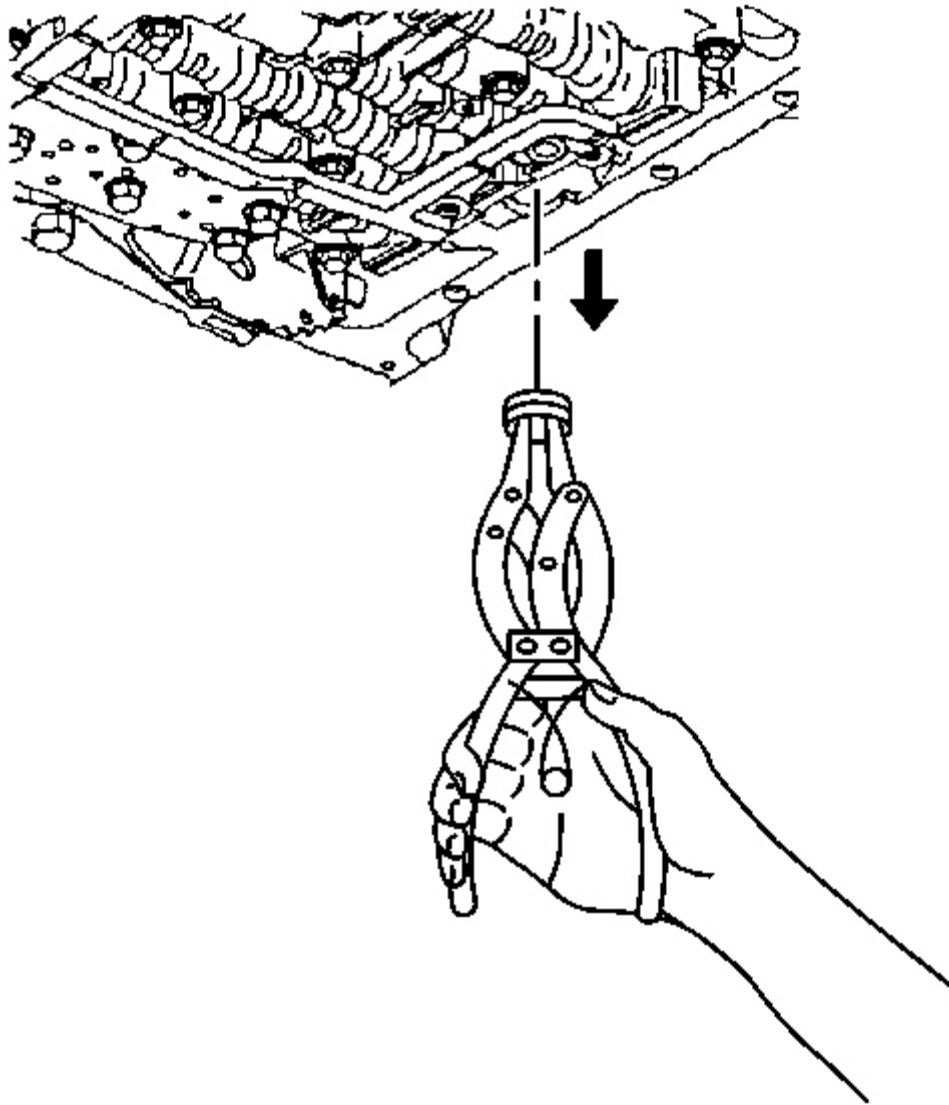

Fig. 63: A/T Filter Seal
Courtesy of GENERAL MOTORS CORP.

12. Remove the filter seal. The filter seal may be stuck in the pump; if necessary, carefully use pliers or another suitable tool to remove the seal.

Discard the seal.

2007 Hummer H3

2007 TRANSMISSION Automatic Transmission - 4L60-E/4L65-E/4L70-E - H3

13. Inspect the fluid color.
14. Inspect the filter. The filter may contain the following evidence for root cause diagnosis:
 - Bronze slivers indicating bushing wear
 - Clutch material
 - Steel particles
15. Clean the transmission case and the oil pan gasket surfaces with solvent and air dry. All traces of the old gasket material must be removed.

Installation Procedure

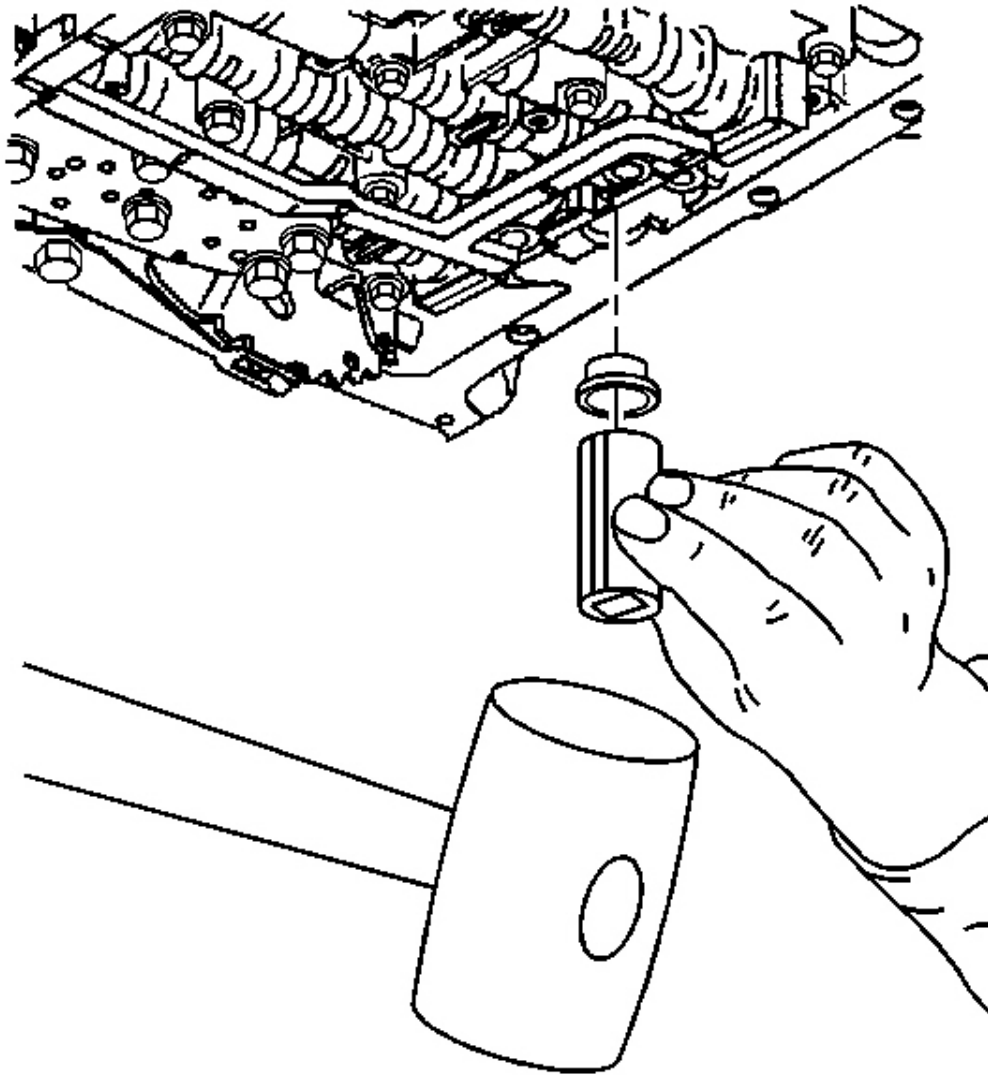

Fig. 64: Installing New Filter Seal Into Transmission Case
Courtesy of GENERAL MOTORS CORP.

1. Coat the new filter seal with clean automatic transmission fluid.
2. Install the new filter seal into the transmission case. Tap the seal into place using a suitable size socket.

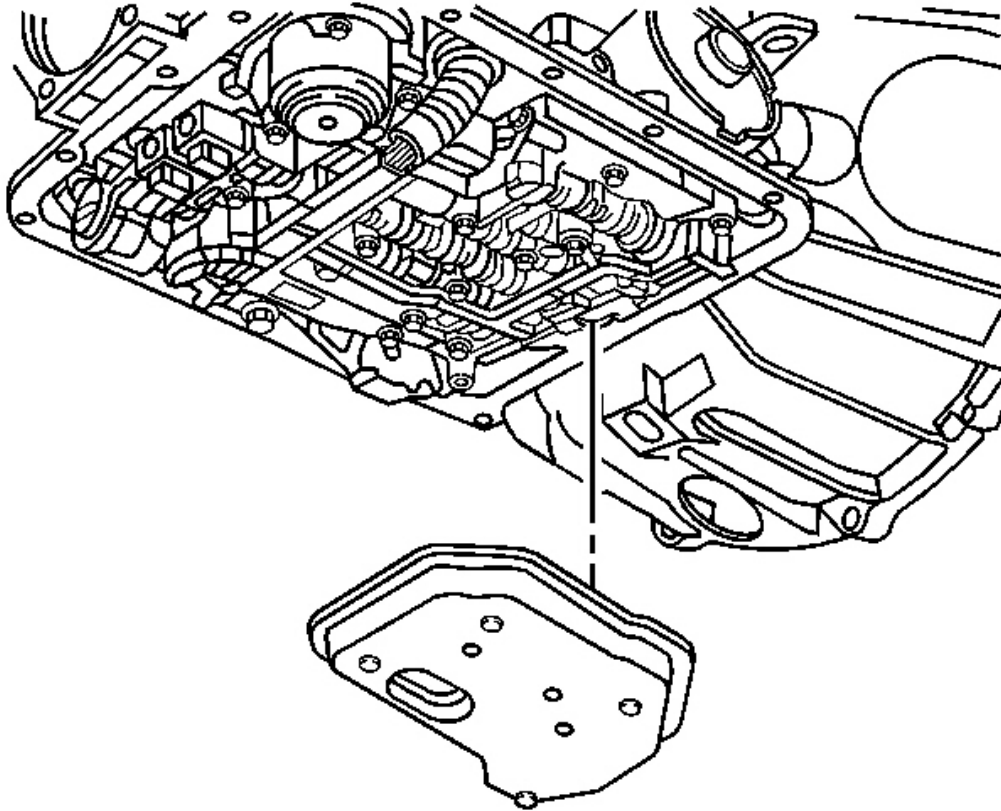

Fig. 65: View Of Filter
Courtesy of GENERAL MOTORS CORP.

3. Install the new filter into the case.

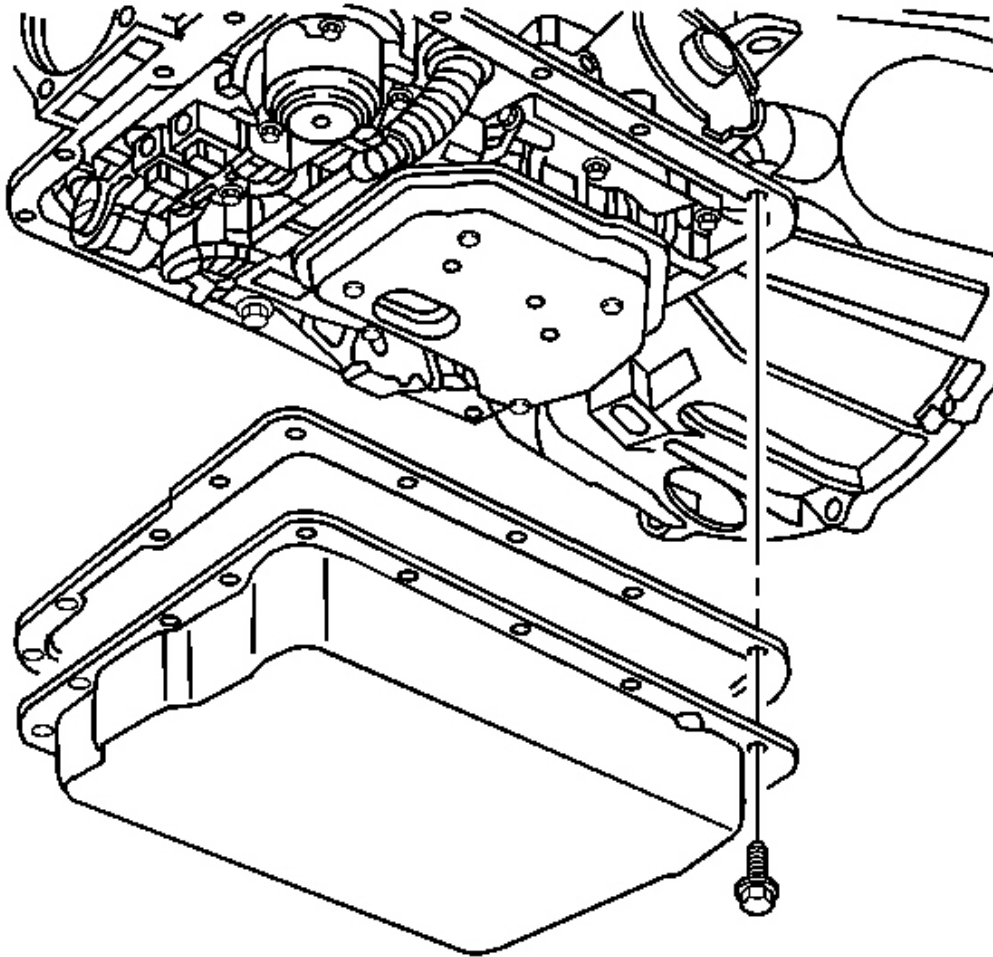

Fig. 66: View Of Oil Pan & Gasket
Courtesy of GENERAL MOTORS CORP.

4. Install the oil pan and a new gasket.

NOTE: Refer to Fastener Notice .

5. Install the oil pan bolts.

Tighten: Tighten the oil pan to transmission case bolts alternately and evenly to 16 N.m (12 lb ft).

6. Remove the container used to catch the used transmission fluid from under the vehicle.

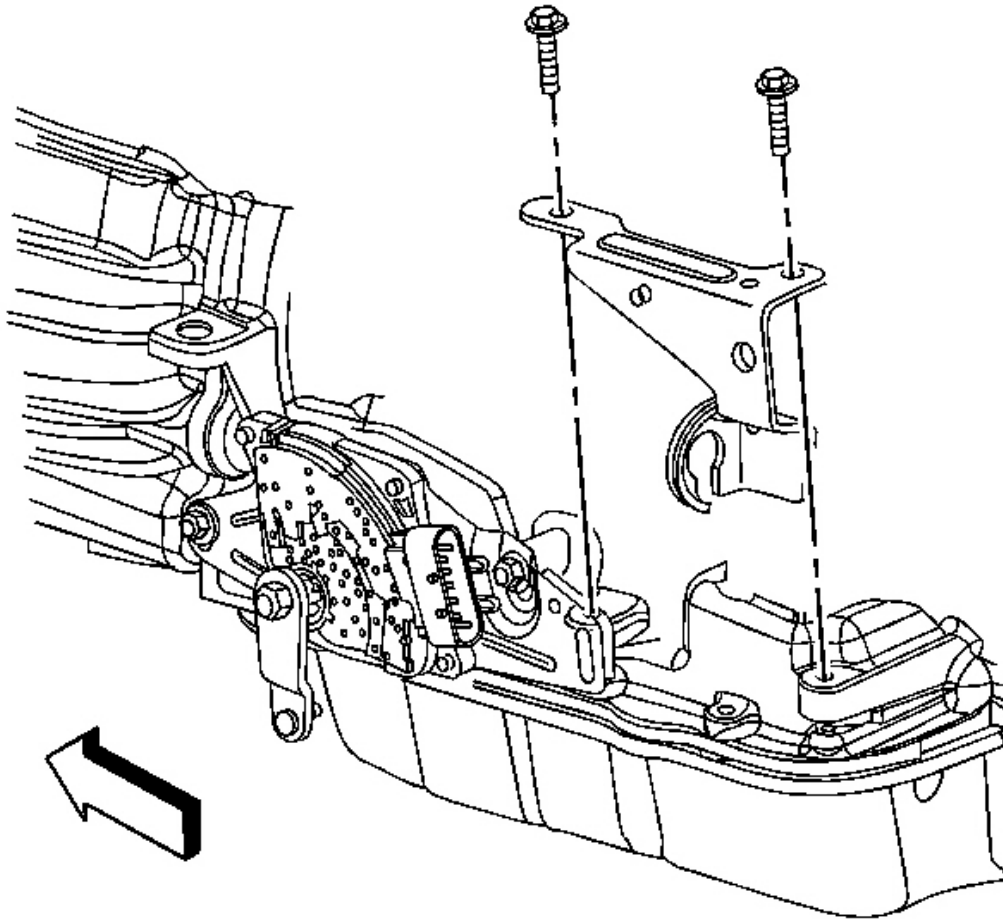

Fig. 67: View Of Transmission Range Selector Cable Bracket
Courtesy of GENERAL MOTORS CORP.

7. Position the transmission range selector cable bracket to the transmission.
8. Install the transmission range selector cable bracket bolts.

Tighten: Tighten the transmission range selector cable bracket bolts to 25 N.m (18 lb ft).

9. Adjust the automatic transmission range selector cable. Refer to **Range Selector Lever Cable Adjustment**.

10. Lower the vehicle.
11. Fill the transmission to the proper level with DEXRON® VI transmission fluid. Refer to **Transmission Fluid Check** and **Fluid Capacity Specifications** .
12. Check the COLD fluid level reading for initial fill only.
13. Inspect the oil pan gasket for leaks.

TORQUE CONVERTER CLUTCH/CRUISE CONTROL RELEASE SWITCH REPLACEMENT

Removal Procedure

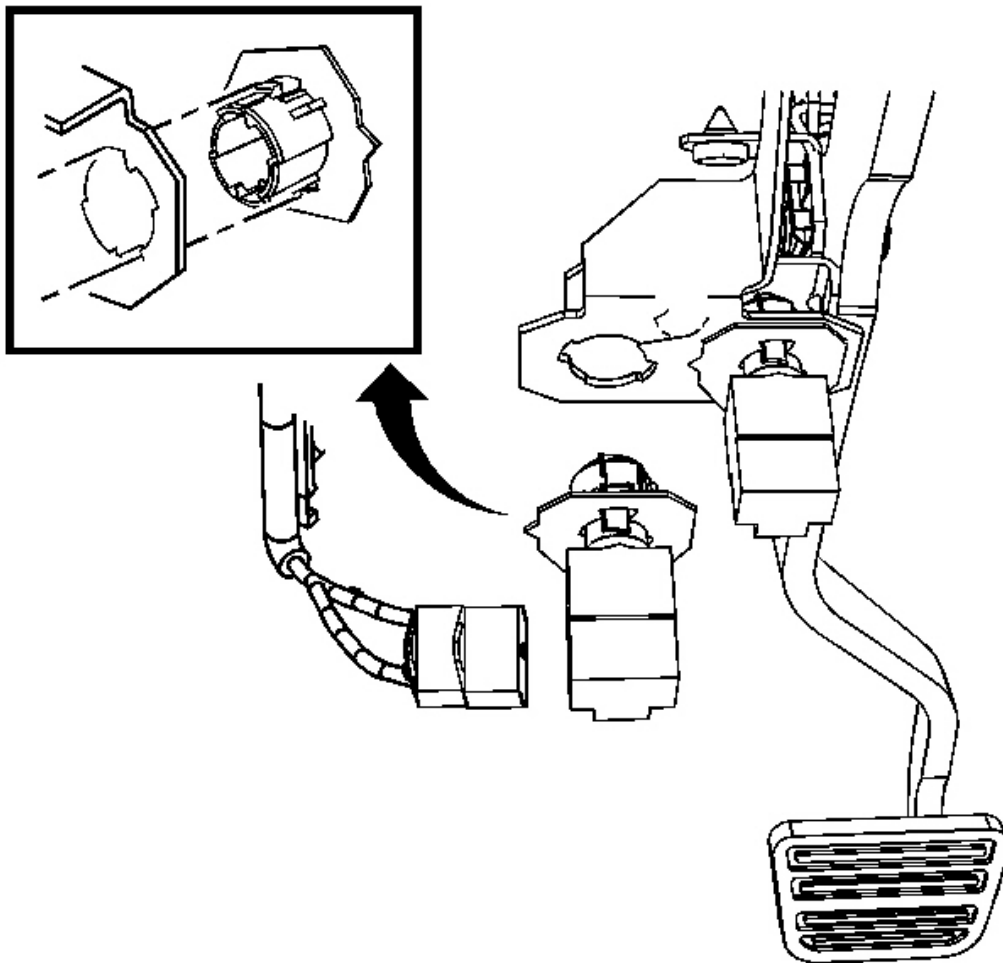

Fig. 68: View Of Cruise Release Switch

2007 Hummer H3

2007 TRANSMISSION Automatic Transmission - 4L60-E/4L65-E/4L70-E - H3

Courtesy of GENERAL MOTORS CORP.

1. Disconnect the electrical connector from the torque converter clutch/cruise control release switch.
2. Complete the following in order to remove the torque converter clutch/cruise control release switch from the brake pedal bracket:
 1. Rotate the switch counter clockwise.
 2. Pull the switch from the retainer.
 3. Push the locking tabs inward to release the retainer.

Installation Procedure

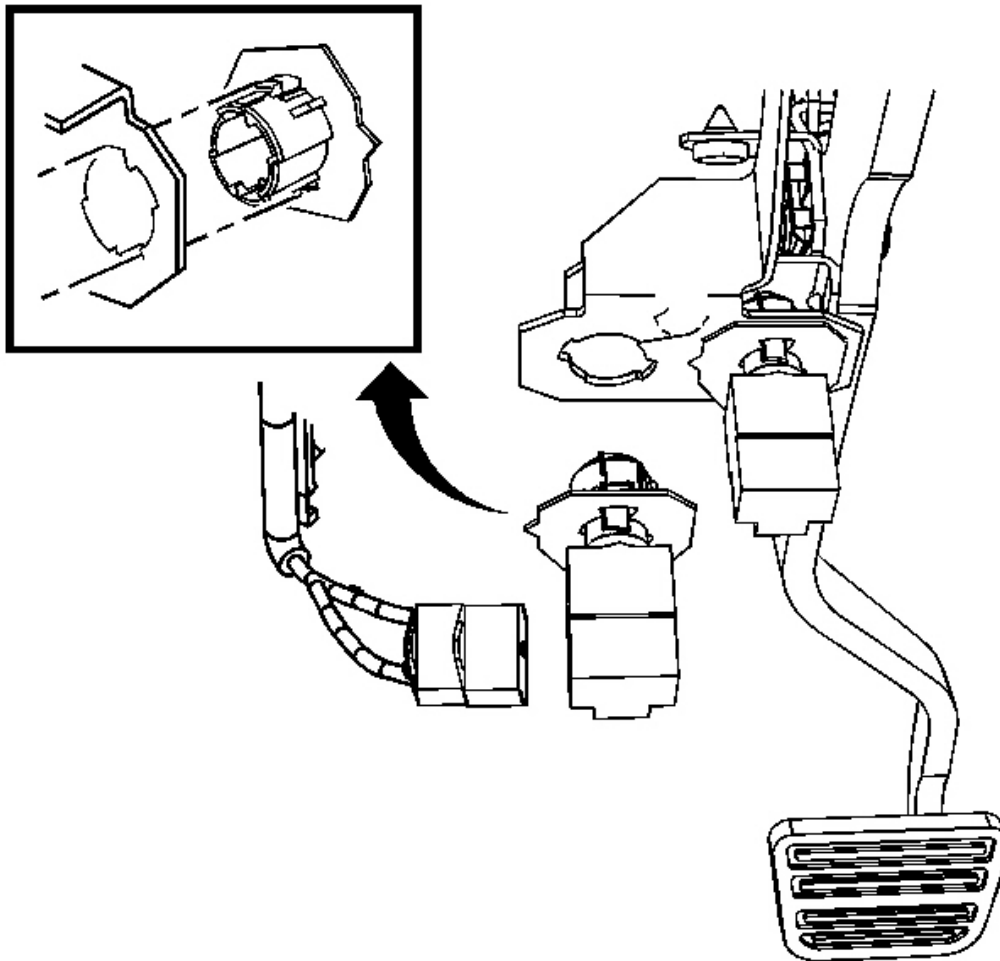

Fig. 69: View Of Cruise Release Switch
Courtesy of GENERAL MOTORS CORP.

1. Slide only the torque converter clutch/cruise control release switch retainer into the brake pedal bracket, until the locking tabs are fully engaged.
2. Connect the electrical connector to the torque converter clutch/cruise control release switch.
3. Adjust the torque converter clutch/cruise control release switch. Refer to **Torque Converter Clutch/Cruise Control Release Switch Adjustment**.

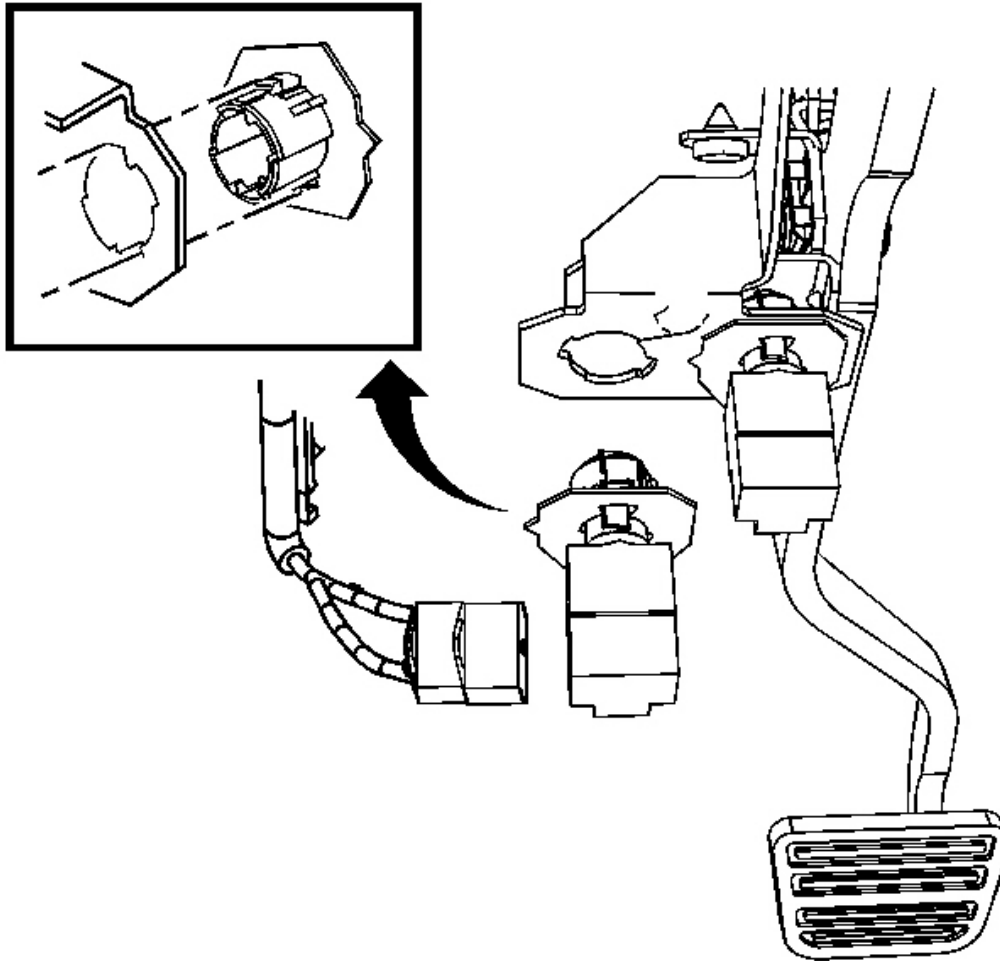

Fig. 70: View Of Cruise Release Switch
Courtesy of GENERAL MOTORS CORP.

1. Rotate the torque converter clutch/cruise control release switch counter clockwise, allowing the retainer to release.
2. Pull the brake pedal rearward to full stop.
3. While holding the brake pedal in position rearward, push the switch inward fully until the switch body contacts the brake pedal arm.

At this point the plunger in the switch should be pushed in.

4. Rotate the switch clockwise until a "click" is heard.

TRANSMISSION FLUID COOLER HOSE/PIPE REPLACEMENT

Removal Procedure

1. Raise the vehicle. Refer to Lifting and Jacking the Vehicle .
2. Disconnect the transmission fluid cooler lines from the radiator. Refer to Transmission Fluid Cooler Hose/Pipe Quick-Connect Fitting Disconnection and Connection.
3. Remove the transmission fluid cooler lines from the retainer located on the radiator.

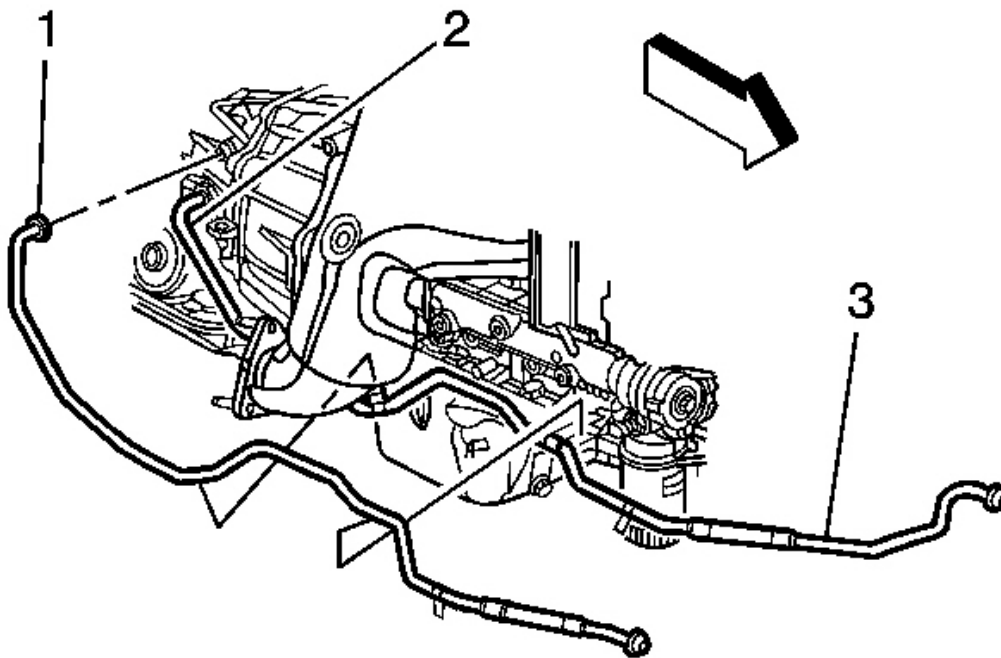

Fig. 71: View Of Transmission Fluid Cooler Lines
Courtesy of GENERAL MOTORS CORP.

4. Remove the transmission fluid cooler lines from the retainer located on the right side of the engine.
5. Support the transmission with a transmission jack.
6. Remove the transmission support. Refer to Transmission Support Crossmember

Replacement .

7. Remove the front exhaust pipe assembly. Refer to **Catalytic Converter Replacement .**
8. Carefully lower the transmission to gain access to the transmission fluid cooler line fittings.
9. Disconnect the transmission fluid cooler lines from the transmission. Refer to **Transmission Fluid Cooler Hose/Pipe Quick-Connect Fitting Disconnection and Connection.**
10. Remove the transmission fluid cooler lines from the vehicle.

Installation Procedure

1. Install the transmission fluid cooler lines to the vehicle.
2. Install the transmission fluid cooler lines to the transmission. Refer to **Transmission Fluid Cooler Hose/Pipe Quick-Connect Fitting Disconnection and Connection.**

NOTE: **Ensure that the cooler line being installed has a plastic cap on each end that connects to a quick connect fitting. If no plastic cap exists or the plastic cap is damaged, obtain a new plastic cap and position on to the cooler line prior to the cooler line installation.**

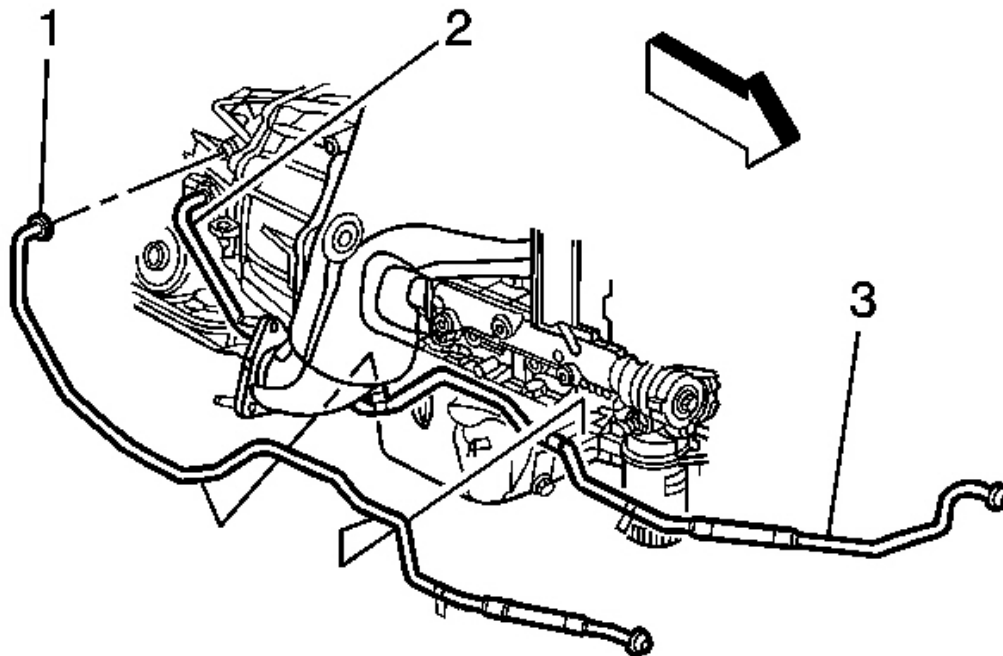

Fig. 72: View Of Transmission Fluid Cooler Lines
Courtesy of GENERAL MOTORS CORP.

3. Raise the transmission into position.
4. Install the front exhaust pipe assembly. Refer to **Catalytic Converter Replacement** .
5. Install the transmission support. Refer to **Transmission Support Crossmember Replacement** .
6. Remove the transmission jack.
7. Install the clip (2) that holds the transmission fluid cooler lines together.
8. Install the transmission fluid cooler lines to the right side of the engine.
9. Install the transmission fluid cooler line to the retainer located on the radiator.
10. Install the transmission fluid cooler lines to the radiator. Refer to **Transmission Fluid Cooler Hose/Pipe Quick-Connect Fitting Disconnection and Connection**.
11. Lower the vehicle.
12. Fill the transmission to the proper level with DEXRON® III transmission fluid. Refer to **Transmission Fluid Check**.

TRANSMISSION FLUID COOLER HOSE/PIPE QUICK-CONNECT FITTING DISCONNECTION DISCONNECTION AND CONNECTION

Removal Procedure

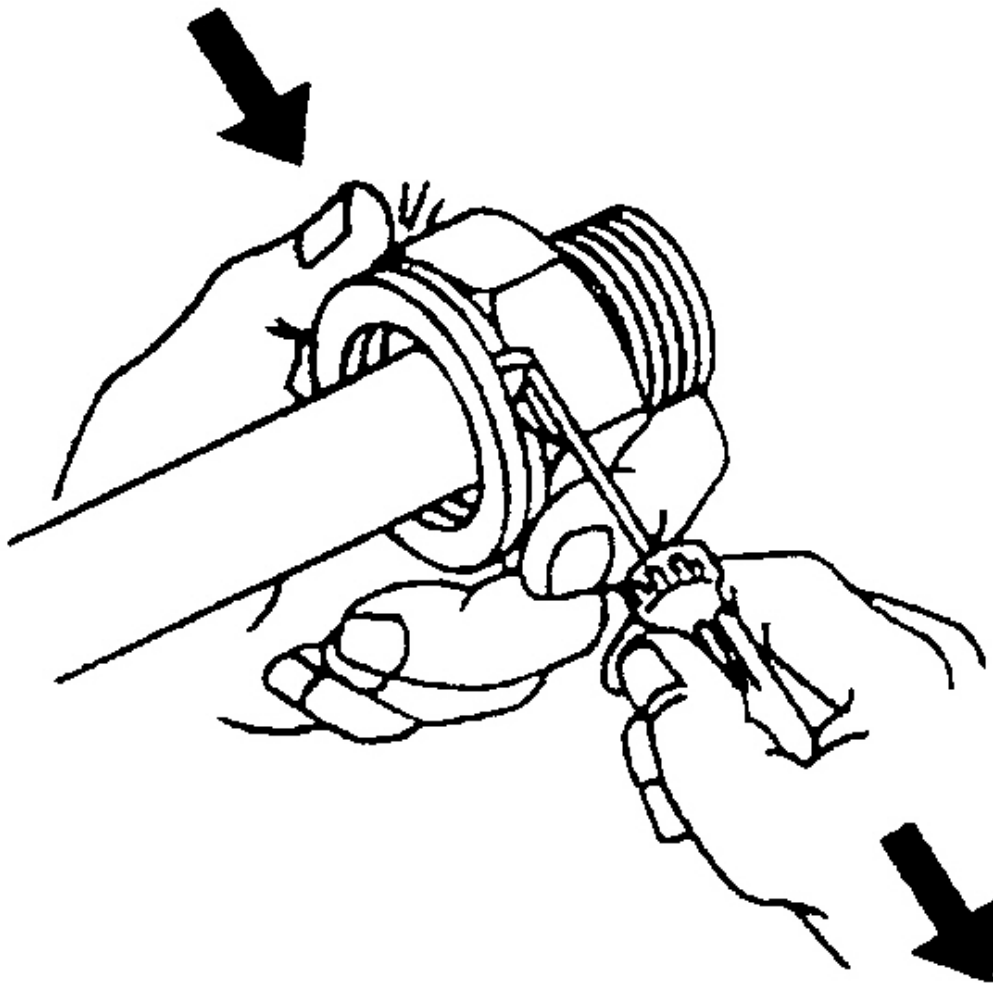

Fig. 73: Removing Retaining Ring For The Quick Connect Fitting
Courtesy of GENERAL MOTORS CORP.

IMPORTANT: Perform the following procedure when removing the retaining rings and cooler lines from the quick connect fittings located on the radiator and/or the transmission.

1. Pull the plastic cap back from the quick connect fitting and down along the cooler line about 5 cm (2 in).
2. Using a bent-tip screwdriver, pull on one of the open ends of the retaining ring in order to rotate the retaining ring around the quick connect fitting until the retaining ring is out of position and can be completely removed.
3. Remove the retaining ring from the quick connect fitting.
4. Discard the retaining ring.

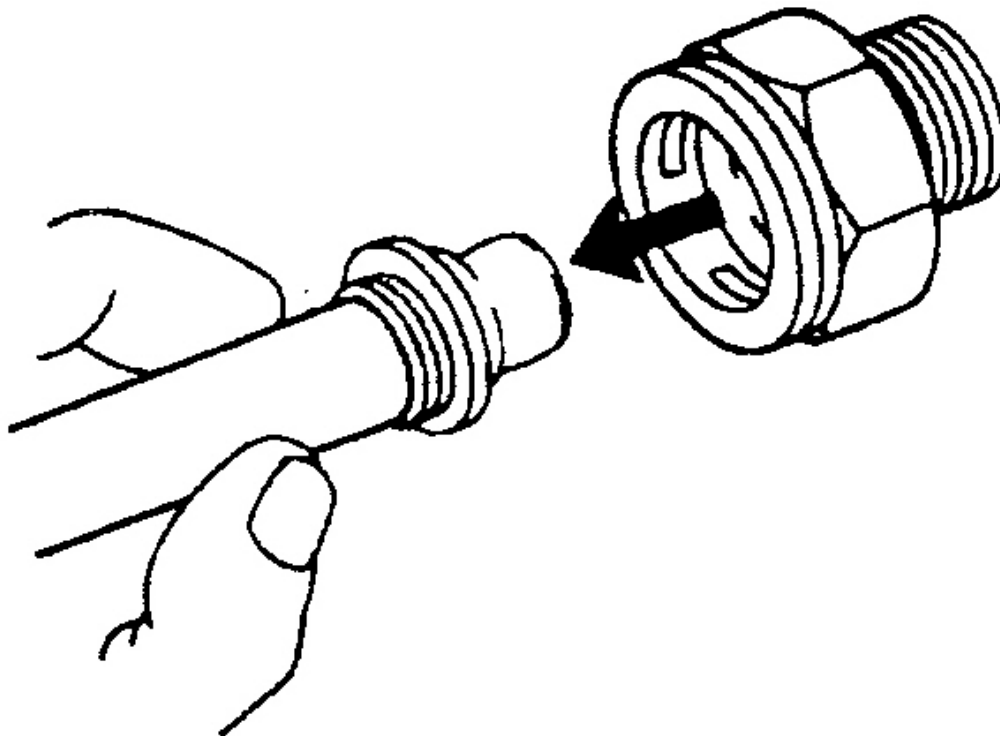

Fig. 74: Cooler Line & Quick Connect Fitting
Courtesy of GENERAL MOTORS CORP.

5. Pull the cooler line straight out from the quick connect fitting.

Installation Procedure

IMPORTANT:

- Do not reuse any of the existing oil lines or oil line fittings if there is excessive corrosion.
- Do not reuse any of the existing retaining rings that were removed from the existing quick connect fittings. Install new retaining rings.
- Ensure the following procedures are performed when installing the new retaining rings onto the fittings.

1. Install a new retaining ring into the quick connect fitting using the following procedure:

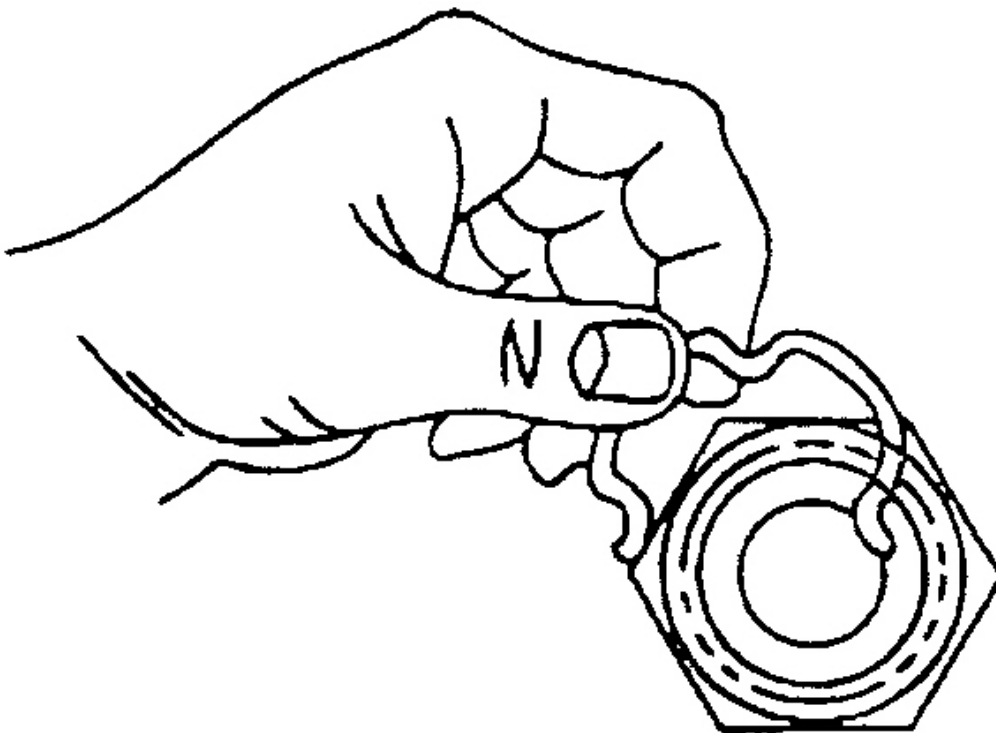

Fig. 75: Hooking Retaining Ring Into Quick Connect Fitting
Courtesy of GENERAL MOTORS CORP.

2. Hook one of the open ends of the retaining ring in one of the slots in the quick connect fitting.

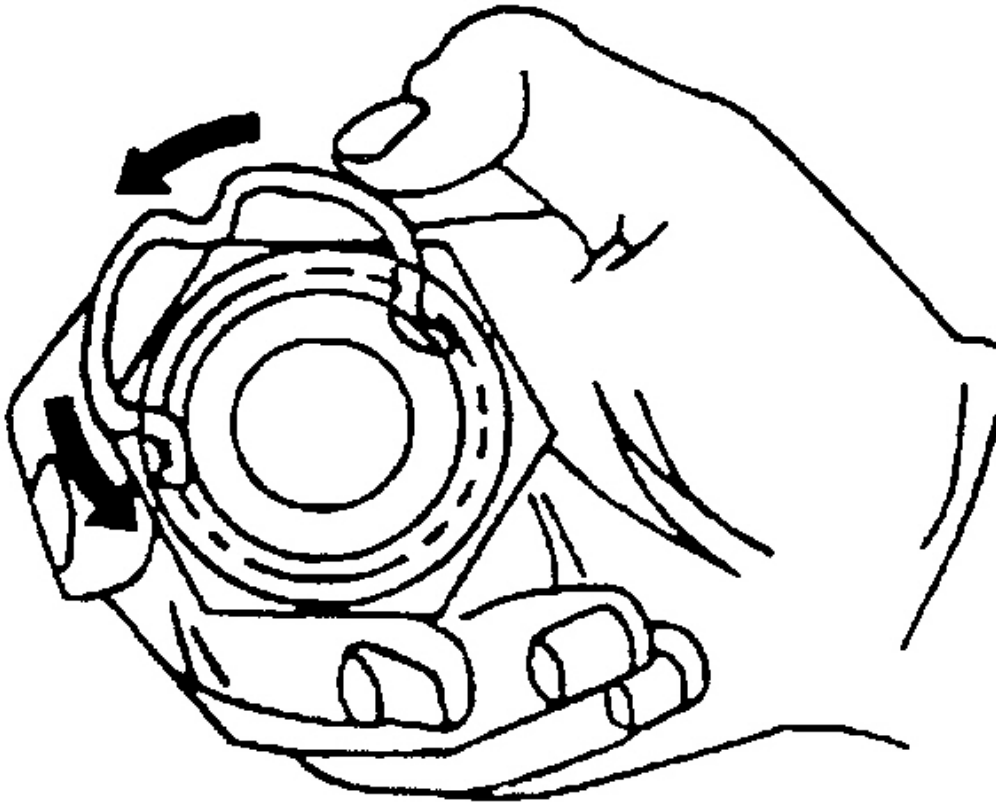

Fig. 76: Rotating Retaining Ring Around Fitting
Courtesy of GENERAL MOTORS CORP.

3. Rotate the retaining ring around the fitting until the retaining ring is positioned with all three ears through the three slots on the fitting.

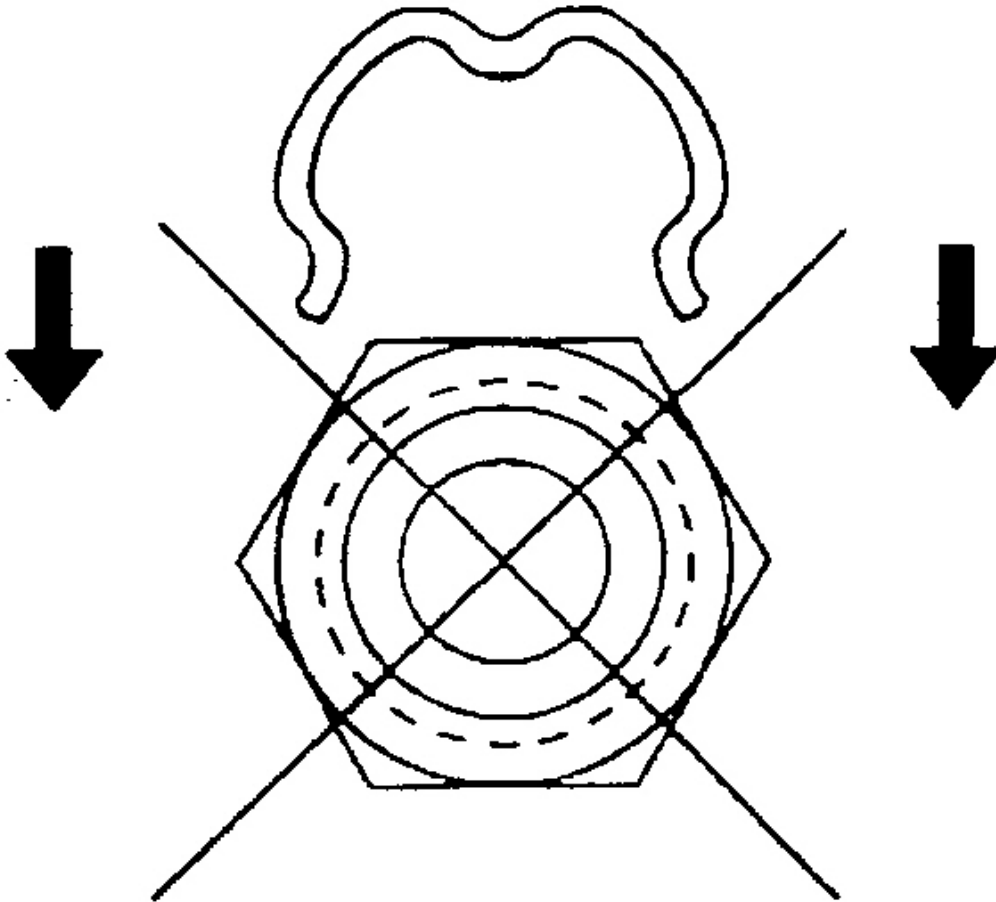

Fig. 77: Identifying Improper Engine Oil Cooler Hose/Pipe Retaining Ring Installation

Courtesy of GENERAL MOTORS CORP.

4. Do not install the new retaining ring onto the fitting by pushing the retaining ring.

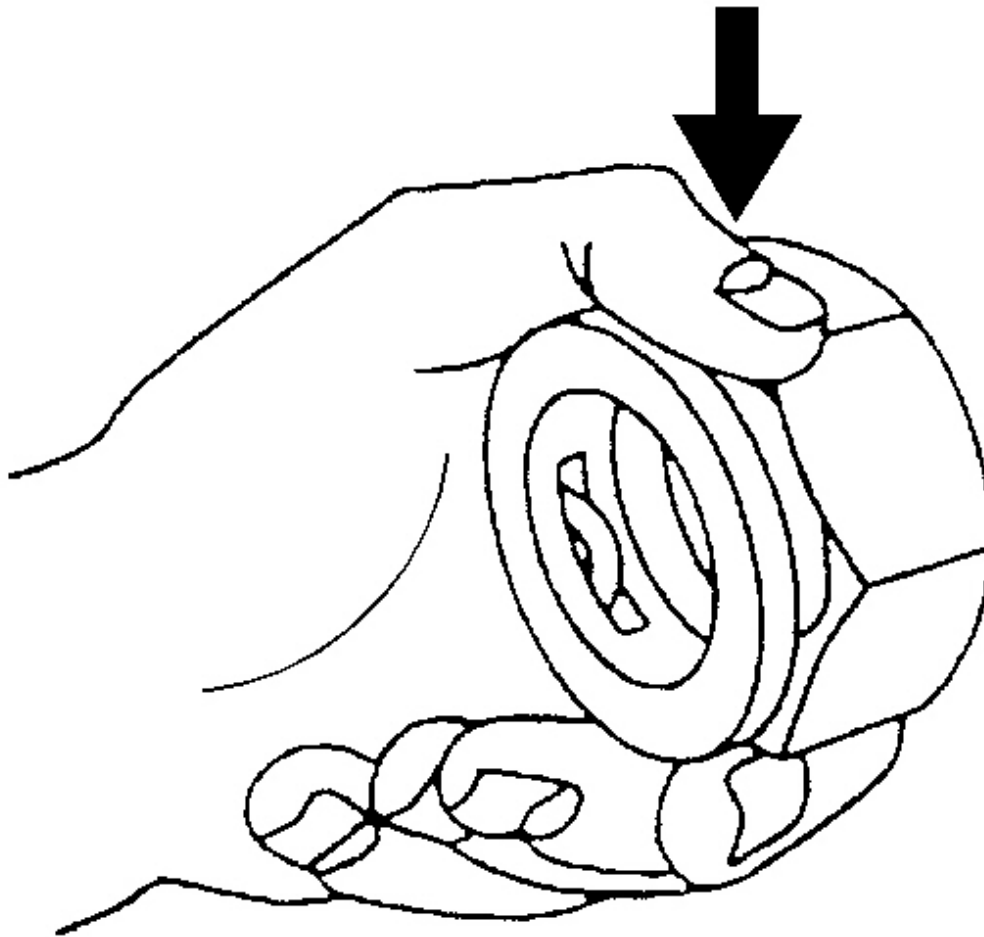

Fig. 78: Ensuring Retaining Ring Is Seated Correctly
Courtesy of GENERAL MOTORS CORP.

5. Ensure that the three retaining ring ears are seen from inside the fitting and that the retaining ring moves freely in the fitting slots.

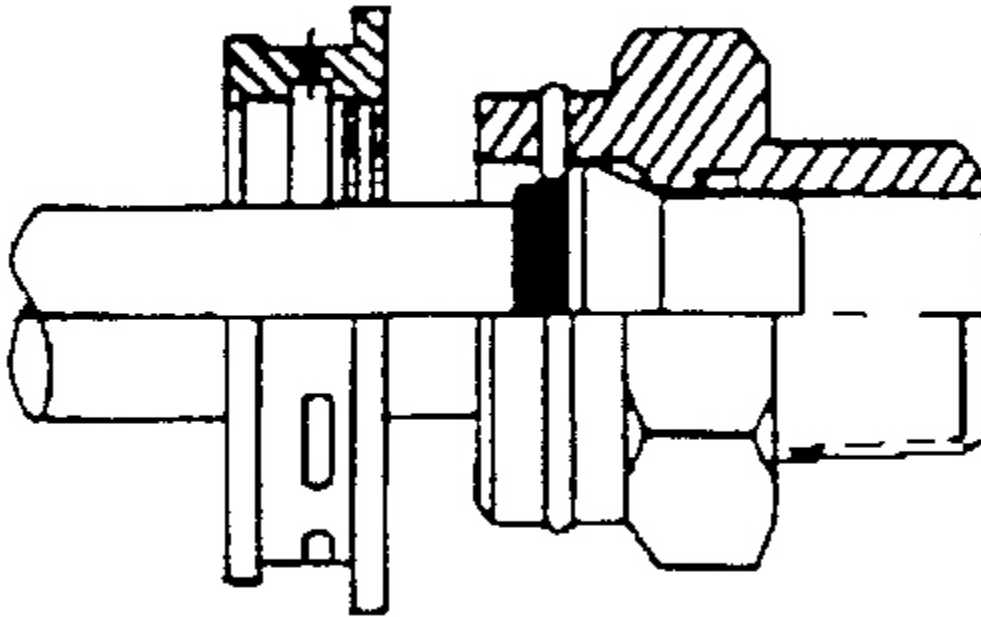

Fig. 79: View Of Cooler Line Quick Connect Fitting
Courtesy of GENERAL MOTORS CORP.

6. Install the cooler line into the quick connect fitting.
7. Insert the cooler line end into the quick connect fitting until a click is either heard or felt.

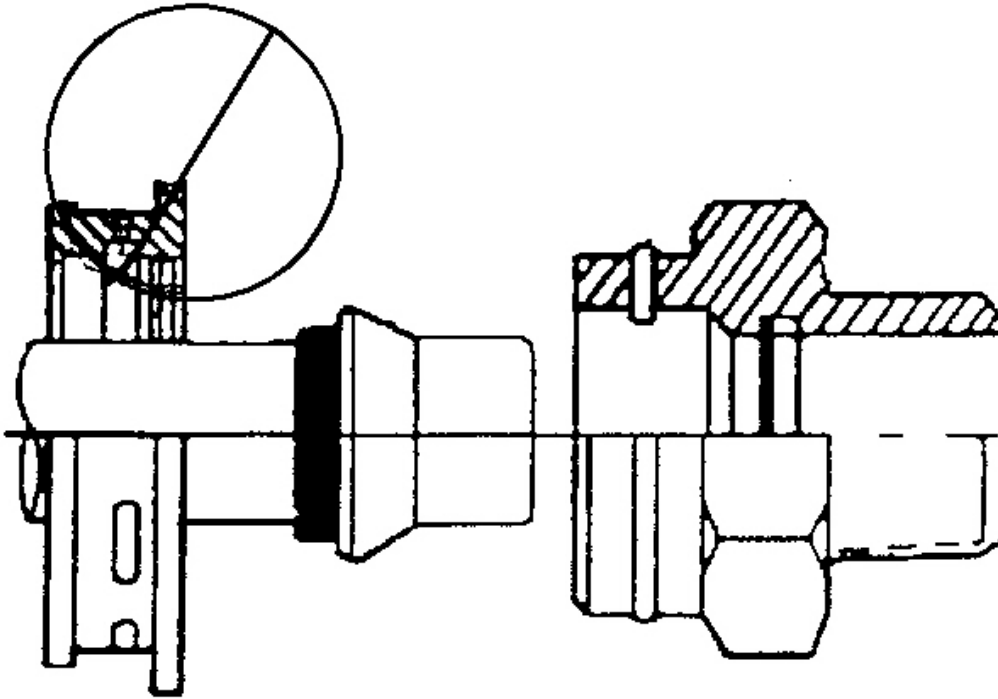

Fig. 80: Do Not Use Plastic Cap On Cooler Line In Order To Install Cooler Line Into The Fitting

Courtesy of GENERAL MOTORS CORP.

8. Do not use the plastic cap on the cooler line in order to install the cooler line into the fitting.
9. Pull back sharply on the cooler line in order to ensure that the cooler line is fastened into the quick connect fitting.

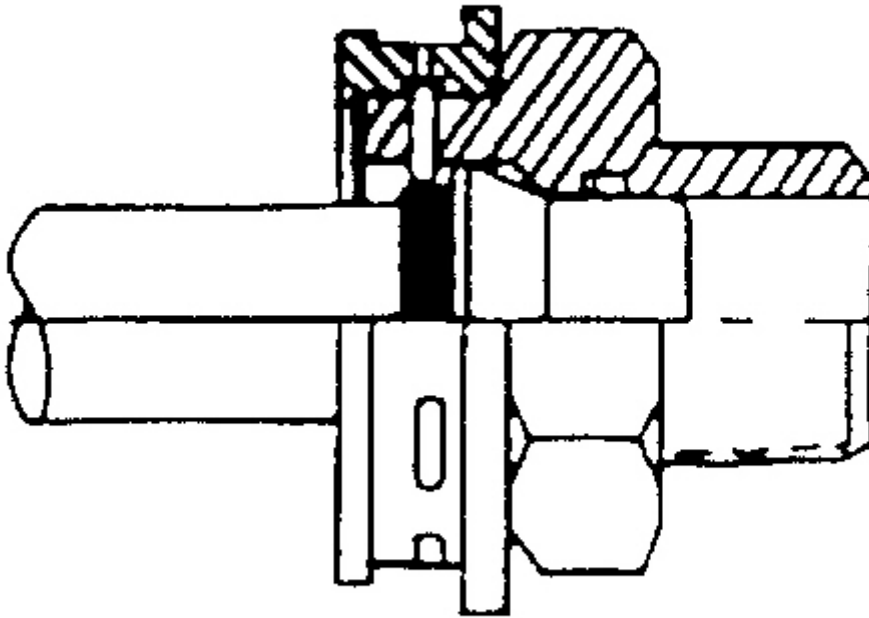

Fig. 81: View Of Cooler Line & Plastic Cap
Courtesy of GENERAL MOTORS CORP.

IMPORTANT: Do not manually depress the retaining clip when installing the plastic cap.

10. Position (snap) the plastic cap onto the fitting. Do not manually depress the retaining ring when installing the plastic cap onto the quick connect fitting.
11. Ensure that the plastic cap is fully seated against the fitting.

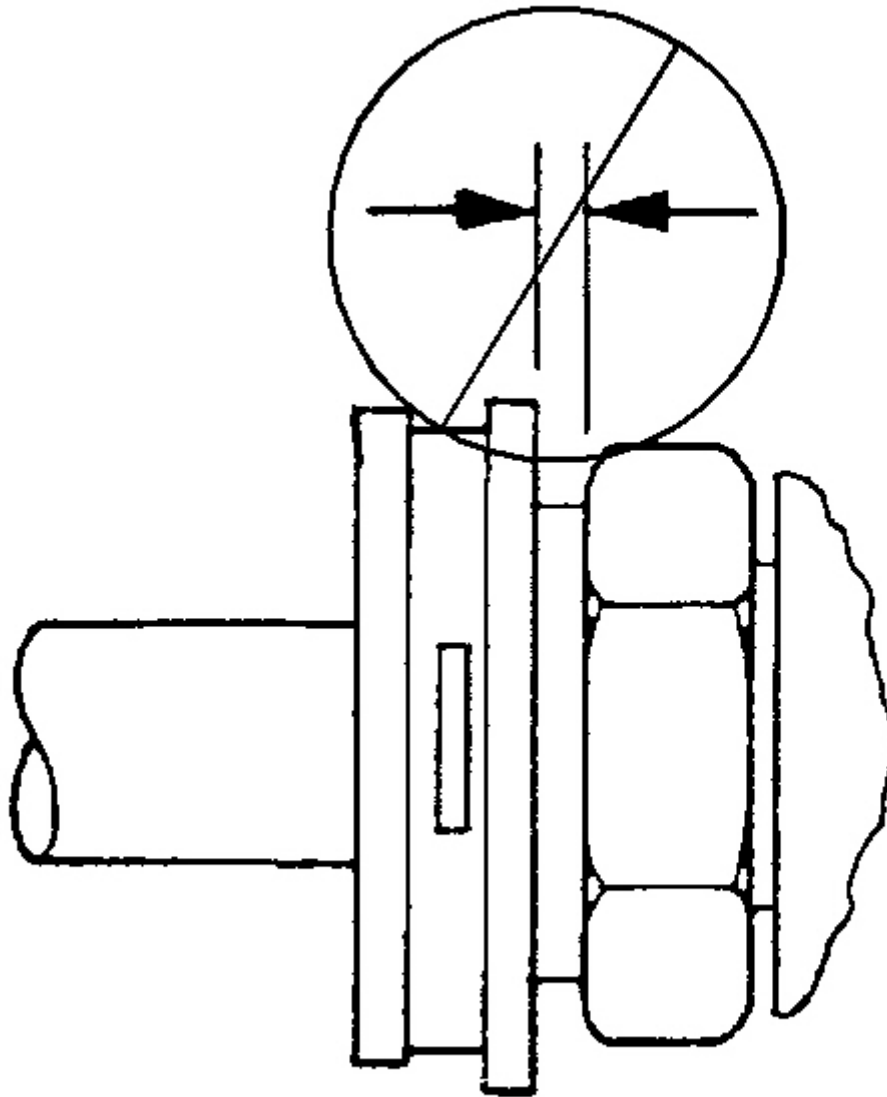

Fig. 82: Checking For Gap Between Cap & Fitting
Courtesy of GENERAL MOTORS CORP.

12. Ensure that no gap is present between the cap and the fitting.

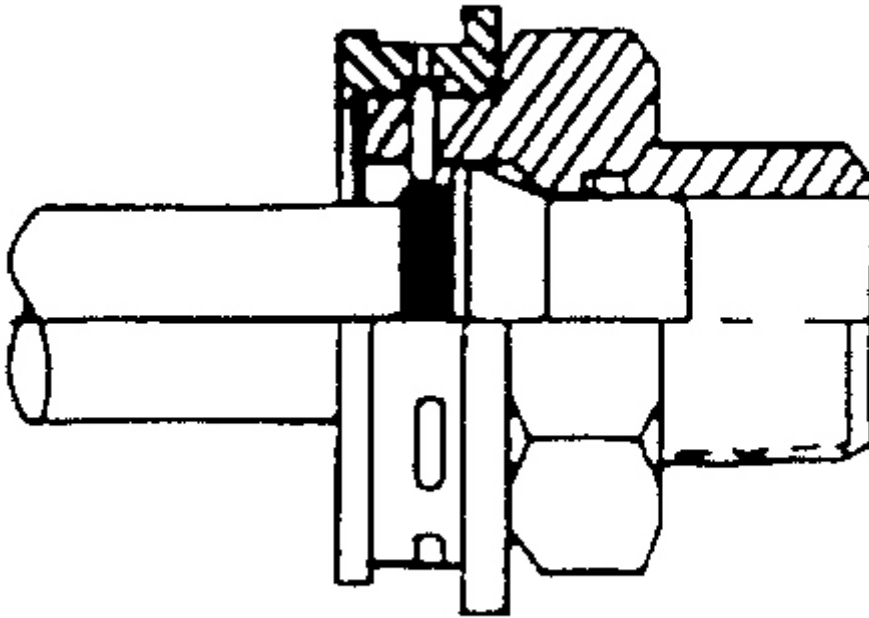

Fig. 83: View Of Cooler Line & Plastic Cap
Courtesy of GENERAL MOTORS CORP.

13. Ensure that the yellow identification band on the tube is hidden within the quick connect fitting.

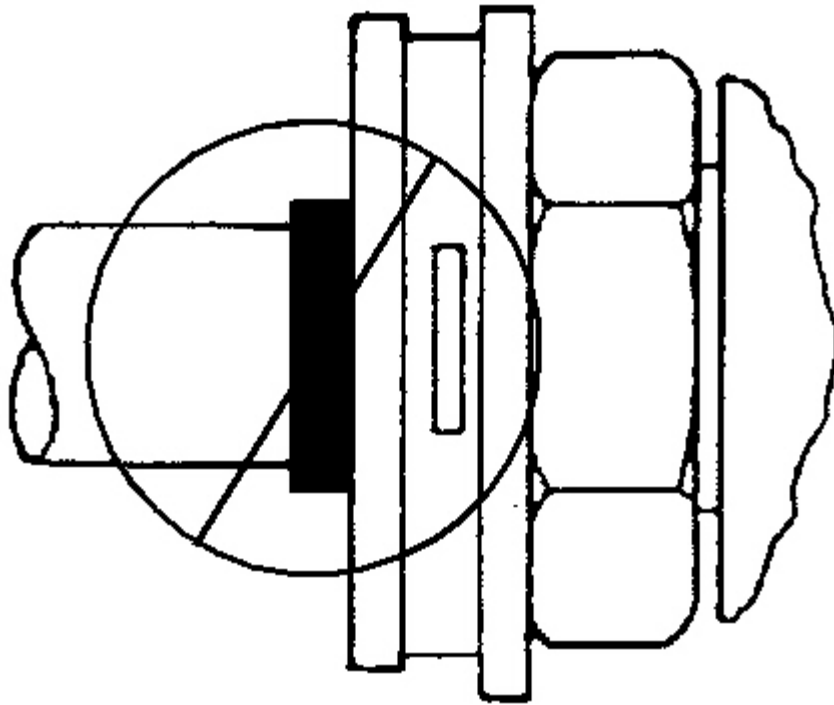

Fig. 84: Identifying Improper Joint Seating
Courtesy of GENERAL MOTORS CORP.

14. A hidden yellow identification band indicates proper joint seating.
15. Fill the transmission to the proper level with DEXRON® VI transmission fluid. Refer to **Transmission Fluid Check**.

AUTOMATIC TRANSMISSION FLUID PRESSURE TEST HOLE PLUG REPLACEMENT

Removal Procedure

1. Raise and support the vehicle. Refer to **Lifting and Jacking the Vehicle** .

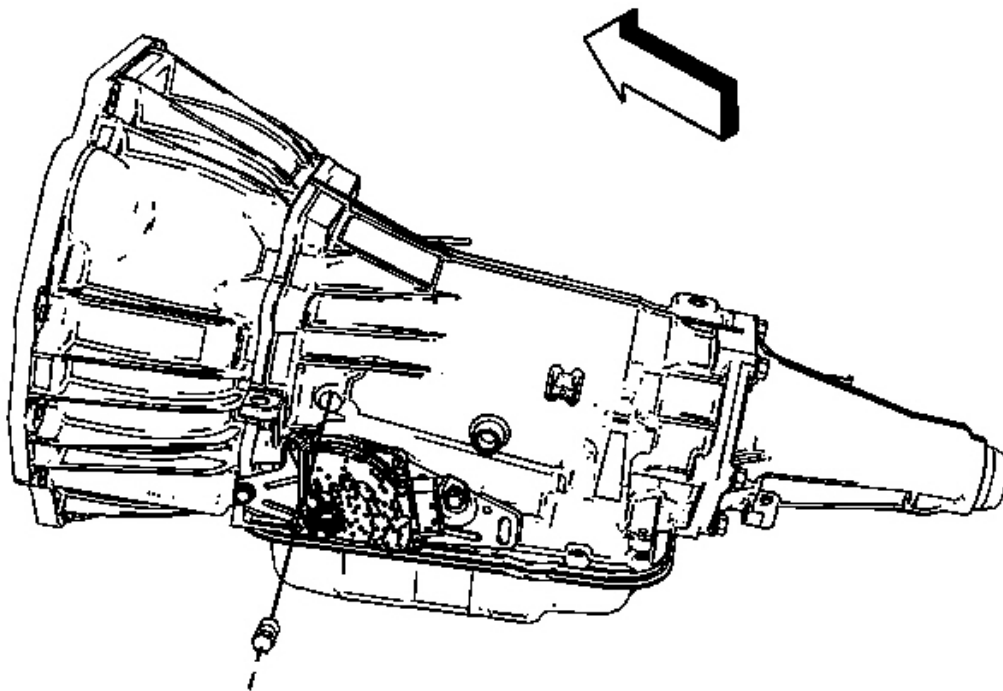

Fig. 85: View Of Oil Pressure Test Plug
Courtesy of GENERAL MOTORS CORP.

2. Remove the oil pressure test plug.

Installation Procedure

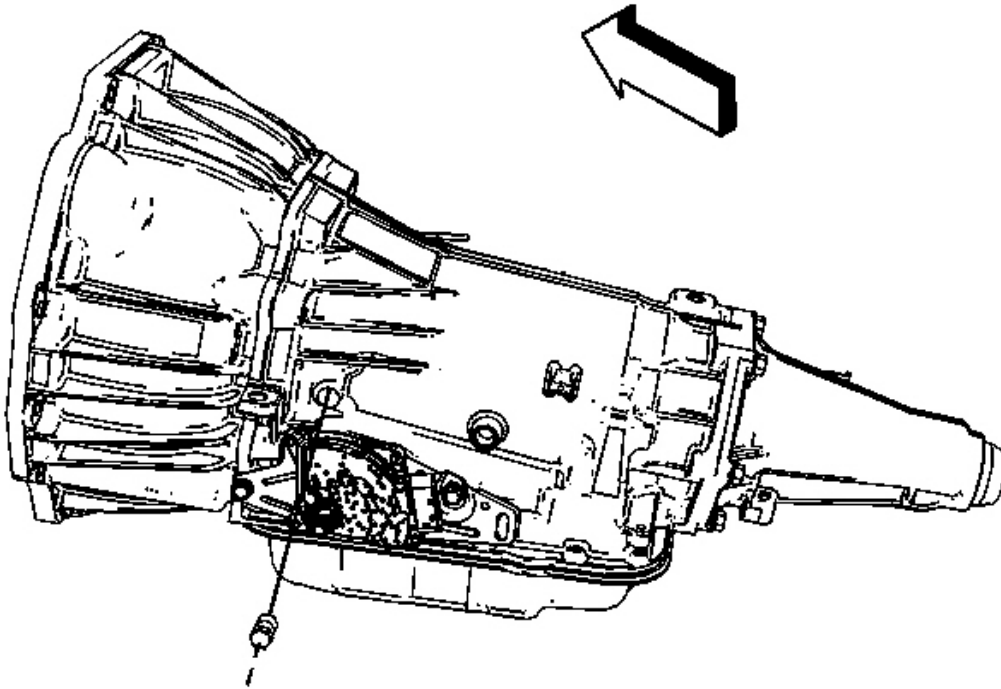

Fig. 86: View Of Oil Pressure Test Plug
Courtesy of GENERAL MOTORS CORP.

NOTE: Refer to Component Fastener Tightening Notice .

1. Install an oil pressure test plug.

Tighten: Tighten the oil pressure test plug to 8 N.m (71 lb in).

2. Check the transmission fluid level, fill if necessary. Refer to Transmission Fluid Check.
3. Lower the vehicle.

VENT HOSE REPLACEMENT

Removal Procedure

1. Raise and support the vehicle. Refer to Lifting and Jacking the Vehicle .

IMPORTANT: Make a note of the routing in order to aid during reassembly.

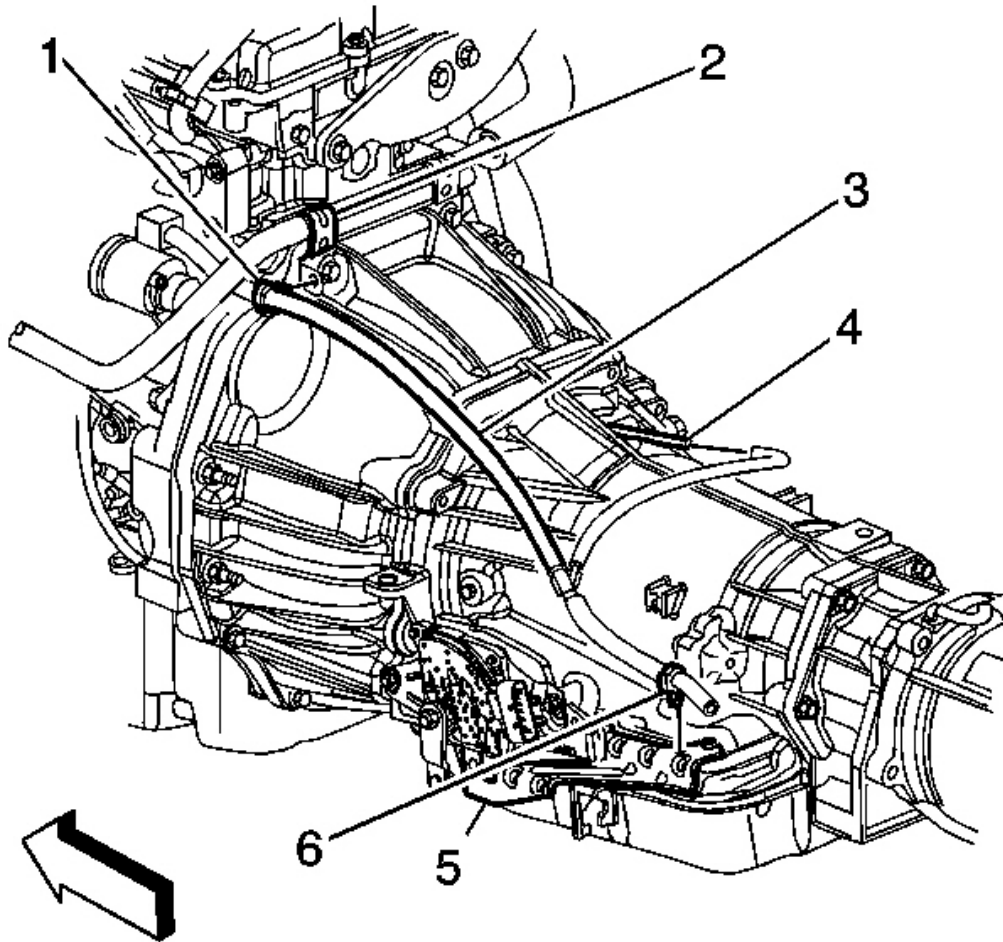

Fig. 87: View Of Transmission Vent Hose & Retainers
Courtesy of GENERAL MOTORS CORP.

2. Disconnect the transmission vent hose retainer (1, 6) from the following:
 - The heater pipe bracket (2)
 - The transmission range selector cable bracket (5)
3. Disconnect the transmission vent hose (3) from the transmission vent tube (4).
4. Remove the transmission vent hose (3).

Installation Procedure

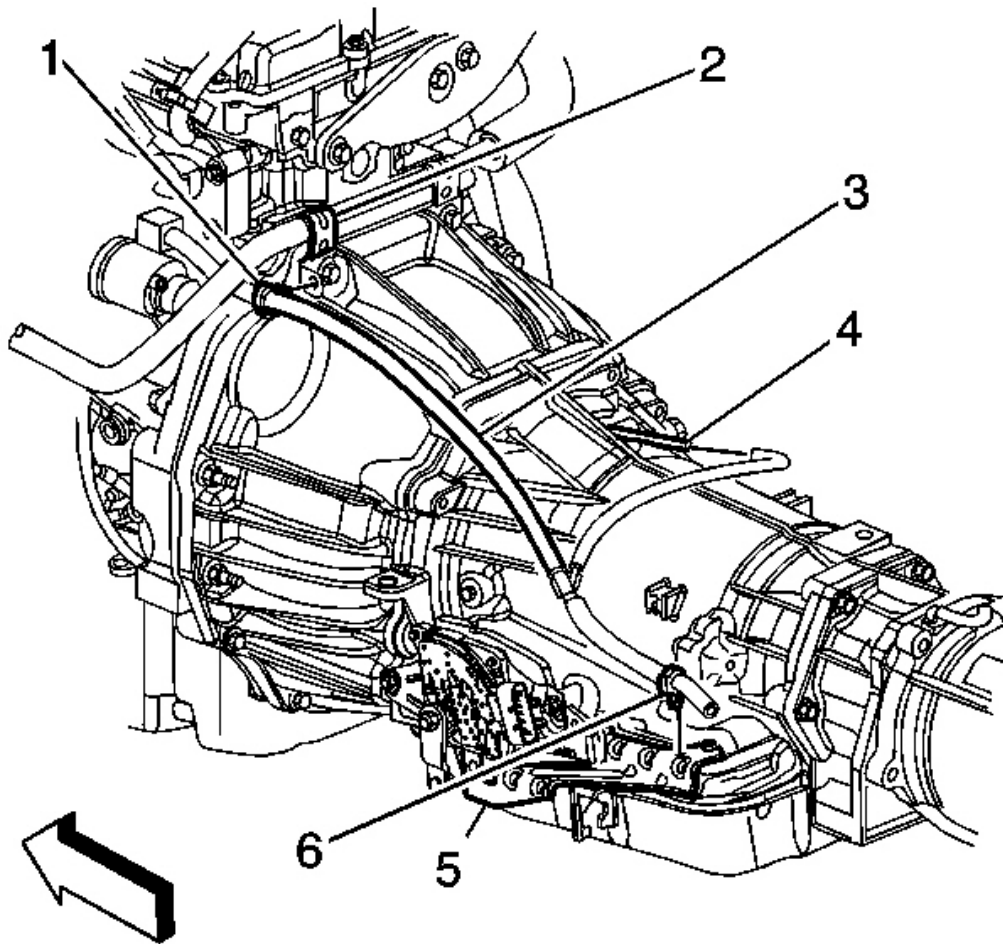

Fig. 88: View Of Transmission Vent Hose & Retainers
Courtesy of GENERAL MOTORS CORP.

IMPORTANT:

- Ensure the vent is not plugged.
- Route the vent hose the same way as removed.
- Ensure the vent hose is free of kinks and is routed clear of sharp objects.

1. Connect the transmission vent hose (3) to the transmission vent tube (4).

2007 Hummer H3

2007 TRANSMISSION Automatic Transmission - 4L60-E/4L65-E/4L70-E - H3

2. Connect the transmission vent hose retainer (1, 6) to the following:
 - The heater pipe bracket (2)
 - The transmission range selector cable bracket (5)
3. Lower the vehicle.

2-4 SERVO

Tools Required

J 29714-A Servo Cover Depressor. See **Special Tools**.

Removal Procedure

1. Raise and support the vehicle. Refer to **Lifting and Jacking the Vehicle** .
2. Remove the front propeller shaft (4WD only). Refer to **Front Propeller Shaft Replacement** .
3. Clean away all dirt and debris from the 2-4 servo cover area.
4. Remove a single transmission oil pan bolt.

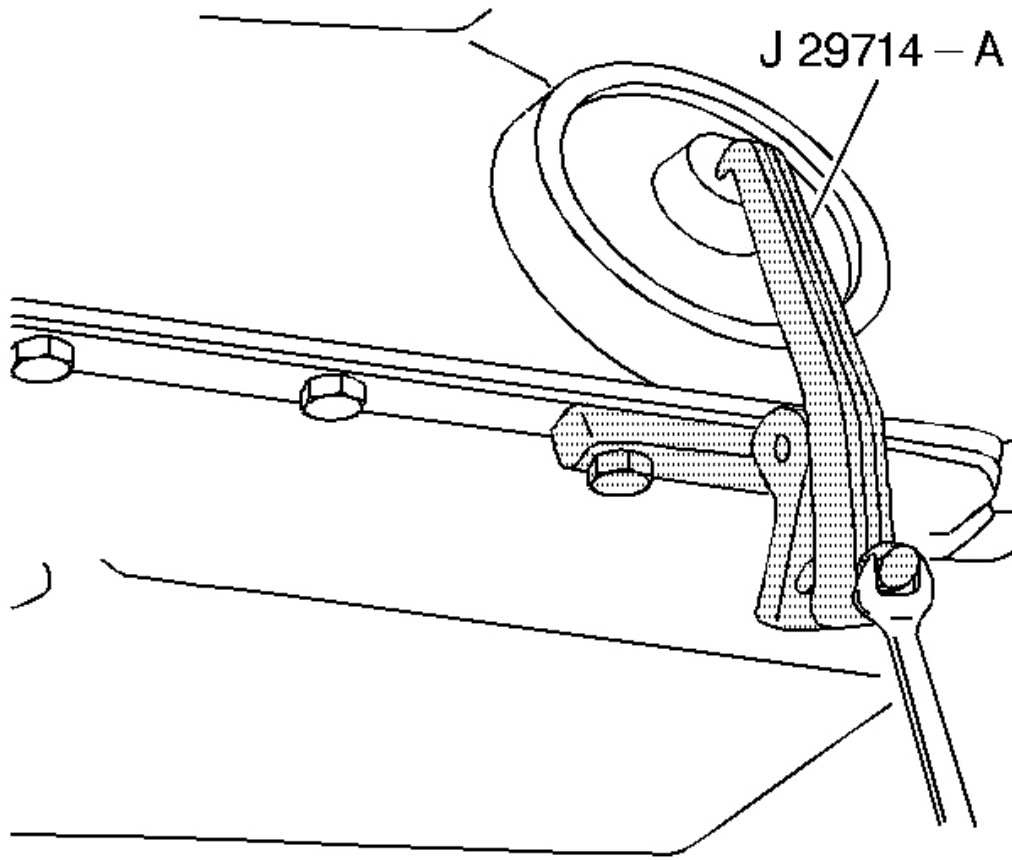

Fig. 89: Compressing The Servo Cover Using J 29714-A
Courtesy of GENERAL MOTORS CORP.

5. Install the **J 29714-A** in place of the transmission oil pan bolt. See **Special Tools**.
6. Tighten the bolt in order to compress the servo cover.

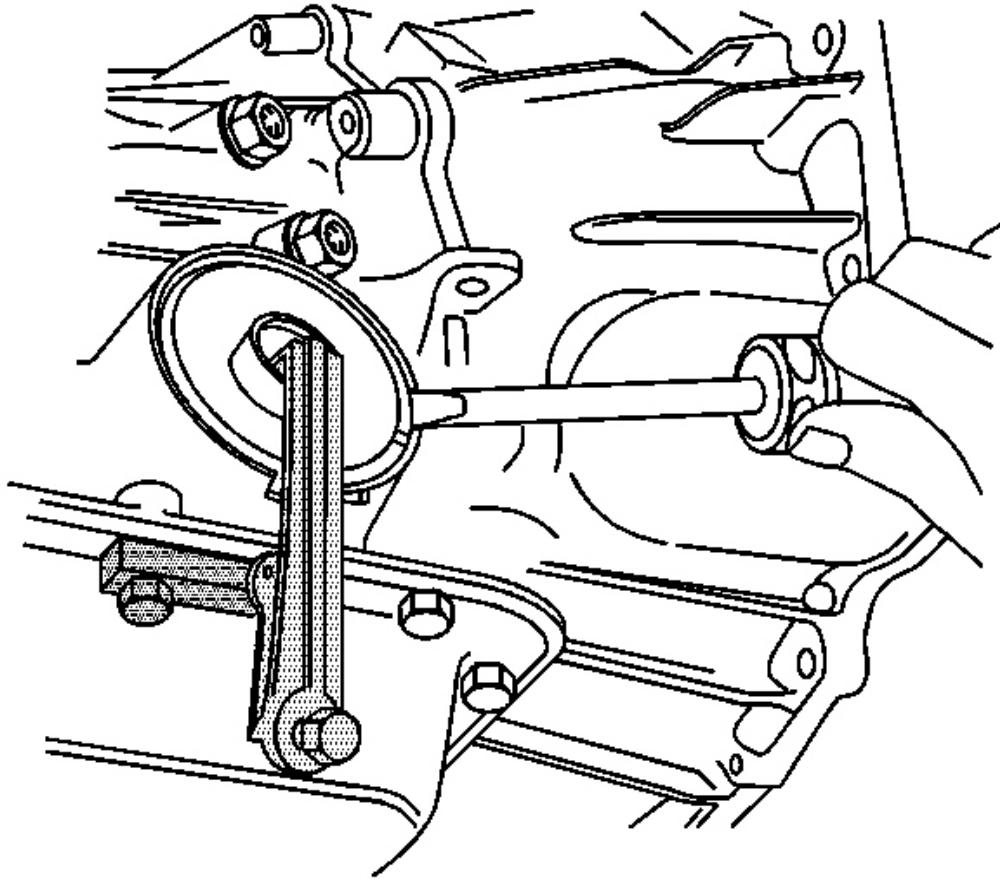

Fig. 90: Removing The Servo Cover Ring
Courtesy of GENERAL MOTORS CORP.

7. Remove the servo cover retaining ring.
8. Remove the J 29714-A . See **Special Tools**.

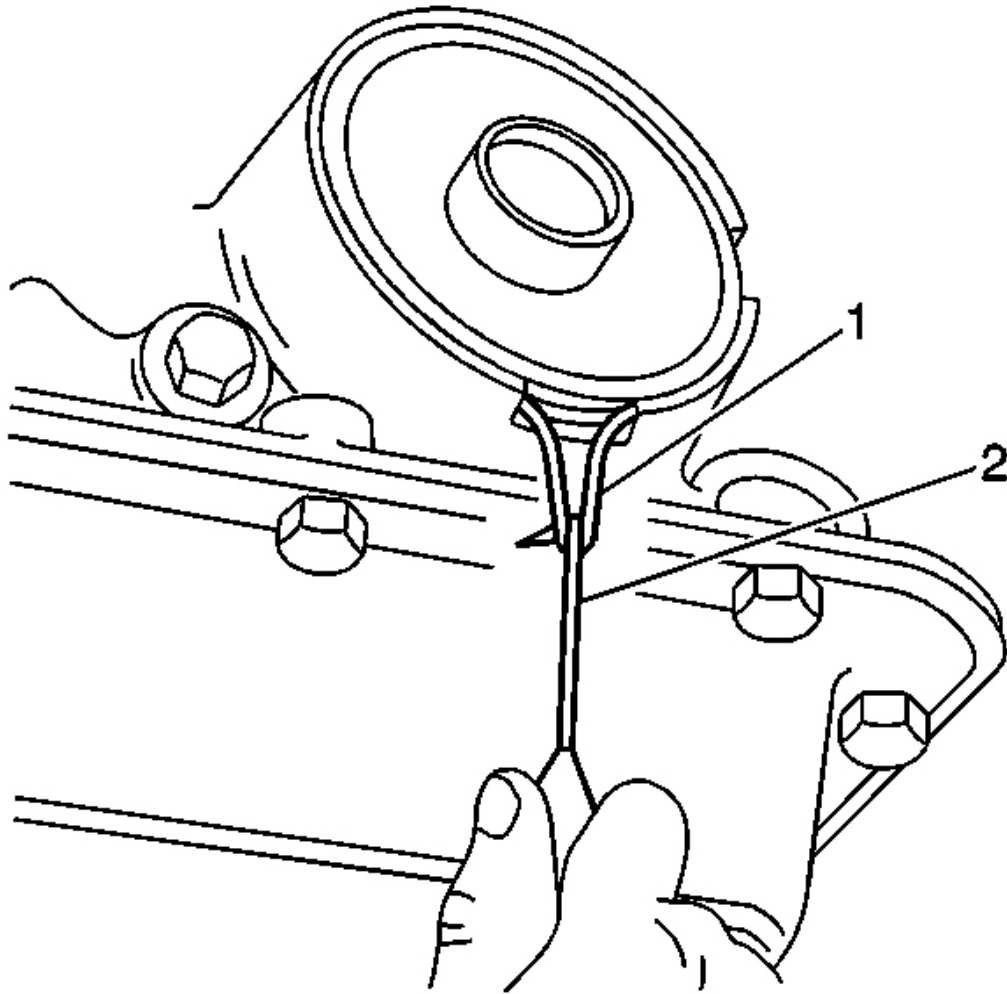

Fig. 91: Removing The Servo Cover And O-Ring Seal
Courtesy of GENERAL MOTORS CORP.

9. Remove the servo cover and the O-ring seal. If the cover is hung up on the seal, use a pick (2) to pull and stretch the seal (1) out of the groove. Cut and remove the O-ring seal before removing the cover.

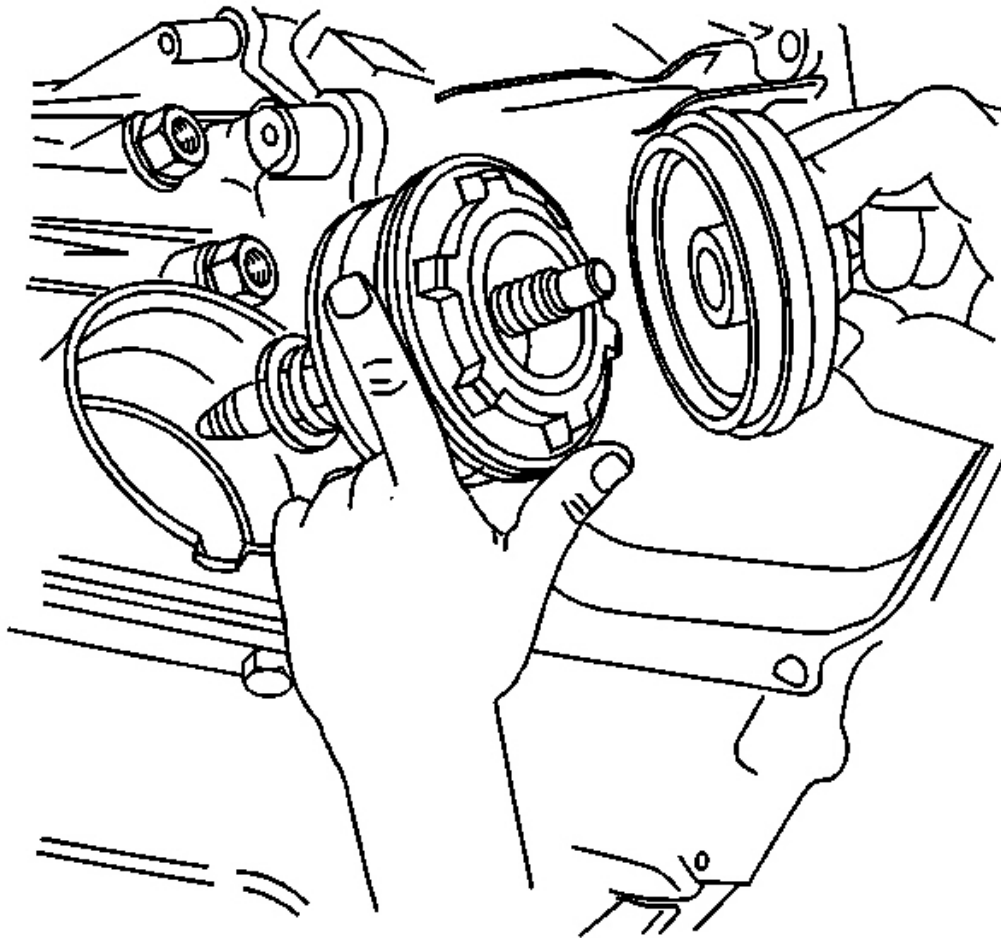

Fig. 92: View Of 2-4 Servo
Courtesy of GENERAL MOTORS CORP.

10. Remove the 2-4 servo from the transmission.
11. Inspect the 4th apply piston, 2-4 servo converter, 2nd apply piston and the servo piston inner housing for the following defects.
 - Cracks
 - Scoring
 - Burrs and nicks
12. Disassemble the 2-4 servo if necessary. Refer to **2-4 Servo Disassemble**.

13. Clean and inspect the 2-4 servo. Refer to 2-4 Servo Pin Length Check.

Installation Procedure

1. Assemble the 2-4 servo if previously disassembled. Refer to 2-4 Servo Assembly Installation.
2. Lightly lubricate the seals with clean transmission fluid.
3. Install new seals on the servo pistons and the servo cover.

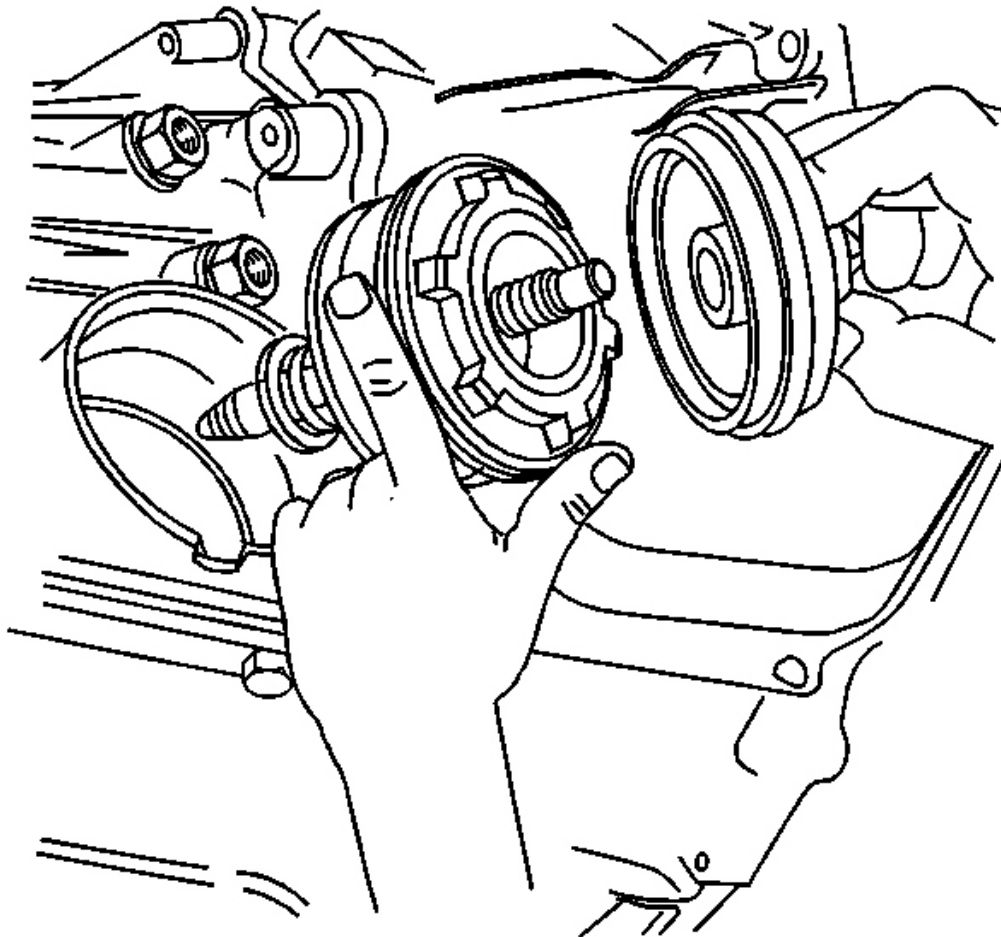

Fig. 93: View Of 2-4 Servo
Courtesy of GENERAL MOTORS CORP.

4. Install the 2-4 servo assembly into the transmission.
5. Install the **J 29714-A** to the transmission oil pan flange. See **Special Tools**.

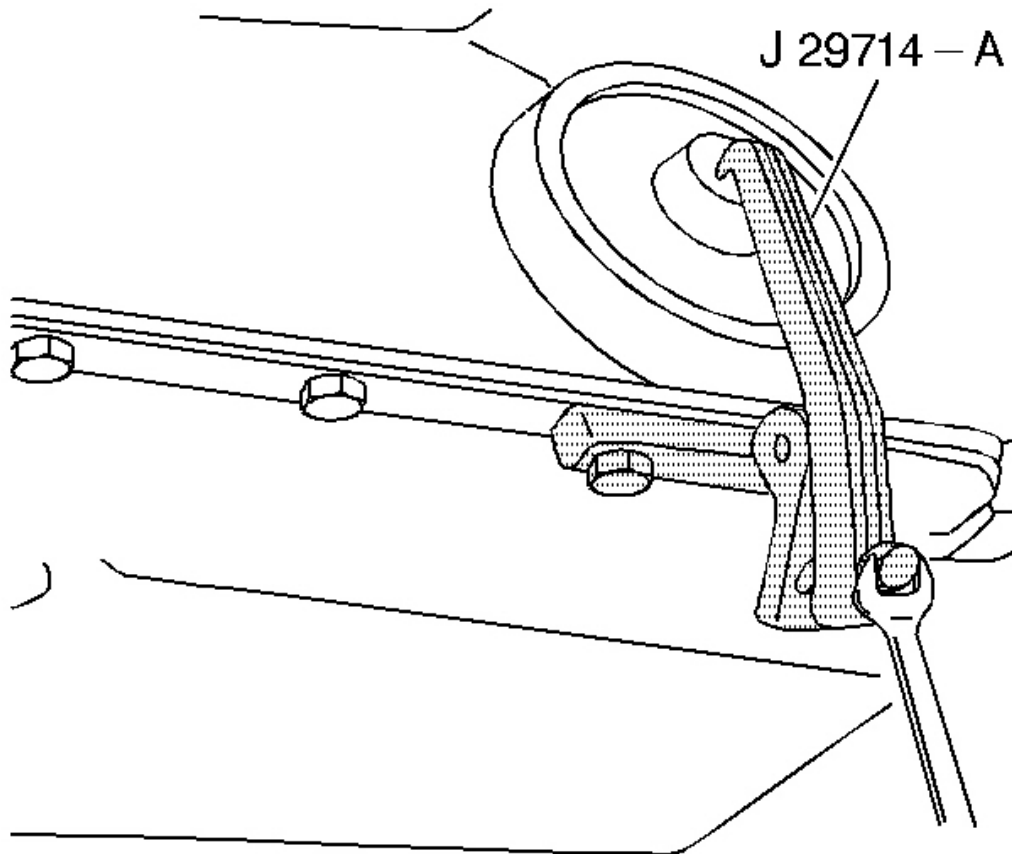

Fig. 94: Compressing The Servo Cover Using J 29714-A
Courtesy of GENERAL MOTORS CORP.

6. Tighten the bolt in order to compress the servo cover.
7. Install the servo cover retaining ring.
8. Remove the **J 29714-A** . See **Special Tools**.

NOTE: Refer to **Fastener Notice** .

9. Install the oil pan bolt.

Tighten: Tighten the oil pan bolt to 11 N.m (97 lb in).

10. Install the front propeller shaft (4WD only). Refer to **Front Propeller Shaft Replacement** .
11. Lower the vehicle.
12. Fill the transmission to the proper level with DEXRON® VI transmission fluid. Refer to **Transmission Fluid Check**.

IMPORTANT: It is recommended that transmission adaptive pressure (TAP) information be reset.

Resetting the TAP values using a scan tool will erase all learned values in all cells. As a result, The ECM, PCM or TCM will need to relearn TAP values. Transmission performance may be affected as new TAP values are learned.

13. Reset the TAP values. Refer to **Transmission Adaptive Functions**.

TORQUE CONVERTER CLUTCH VALVE AND SPRING REPLACEMENT

Removal Procedure

1. Remove the transmission filter. Refer to **Automatic Transmission Fluid and Filter Replacement**.

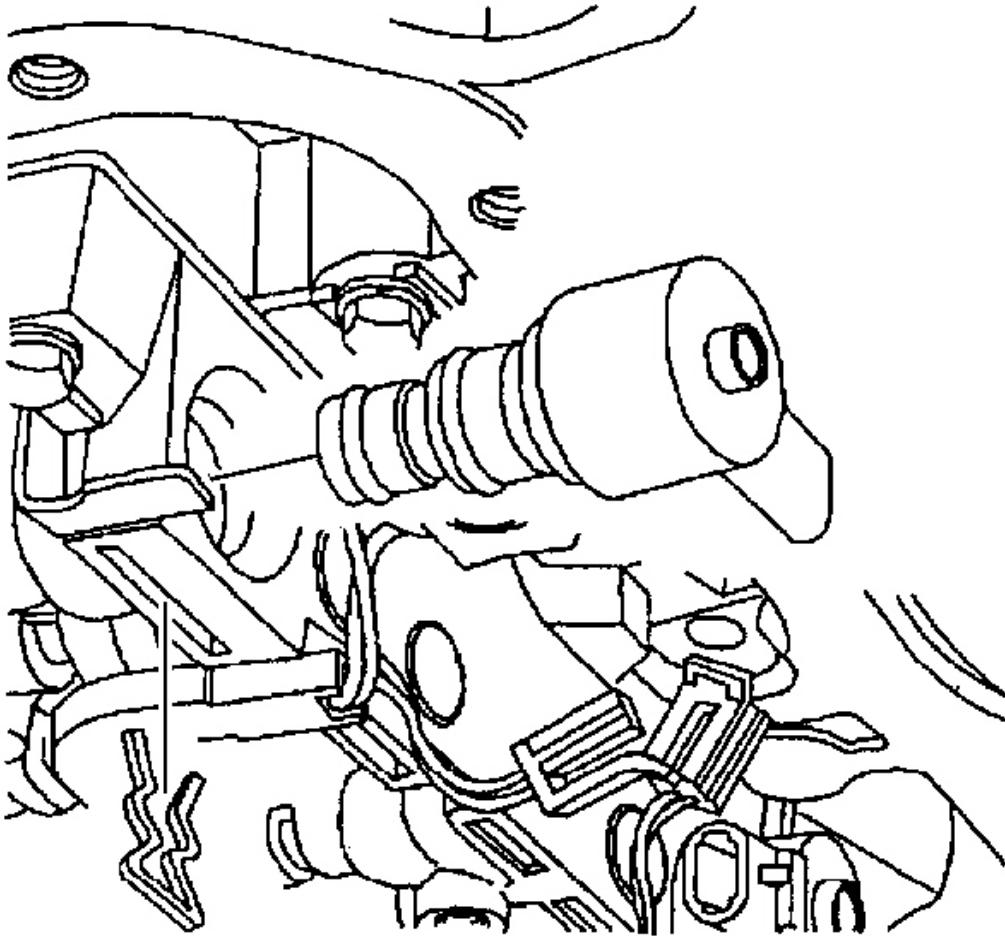

Fig. 95: View Of TCC PWM Solenoid & Retainer
Courtesy of GENERAL MOTORS CORP.

2. Disconnect the torque converter clutch (TCC) pulse width modulation (PWM) solenoid electrical connector.
3. Remove the TCC PWM solenoid retainer.
4. Remove the TCC PWM solenoid in order to access the TCC control solenoid bolts.

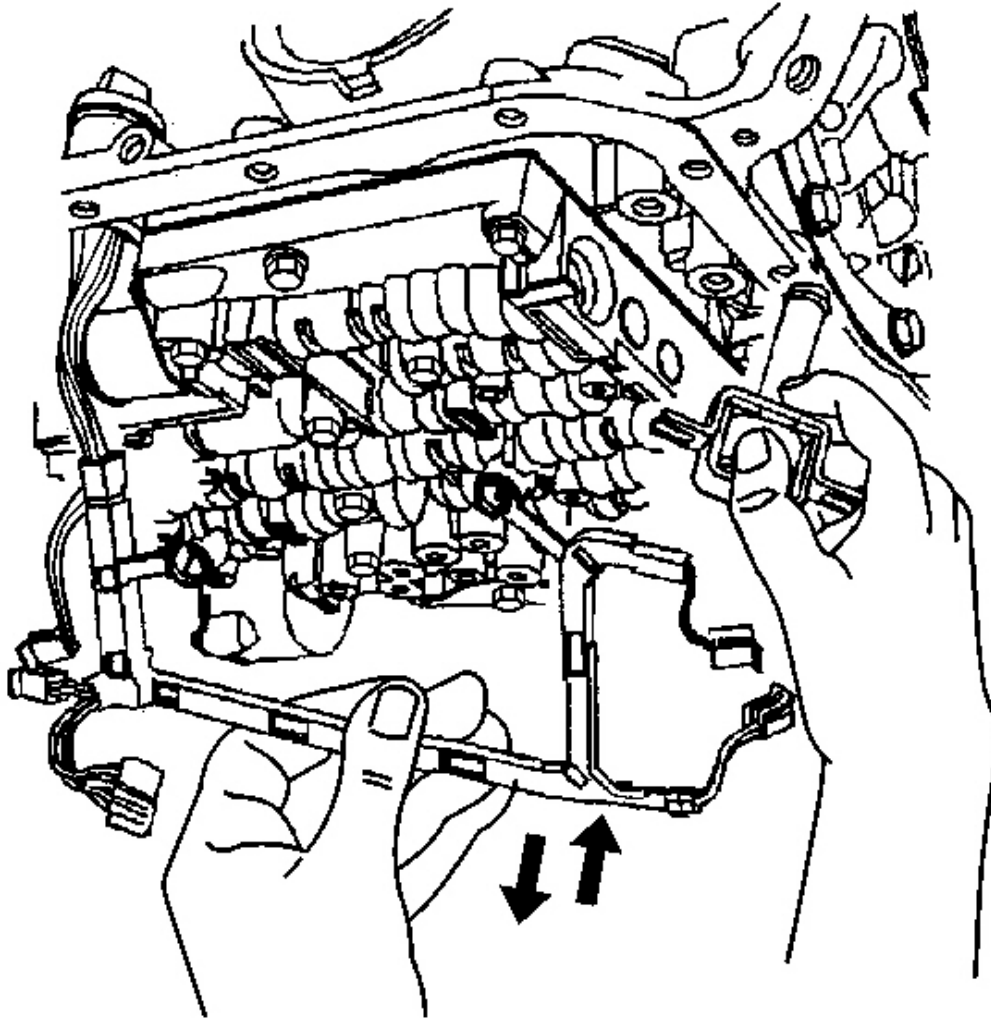

Fig. 96: View Of TCC Solenoid & Wiring Harness
Courtesy of GENERAL MOTORS CORP.

5. Disconnect the TCC control solenoid connector.
6. Remove the TCC control solenoid retaining bolts.
7. Remove the TCC control solenoid.

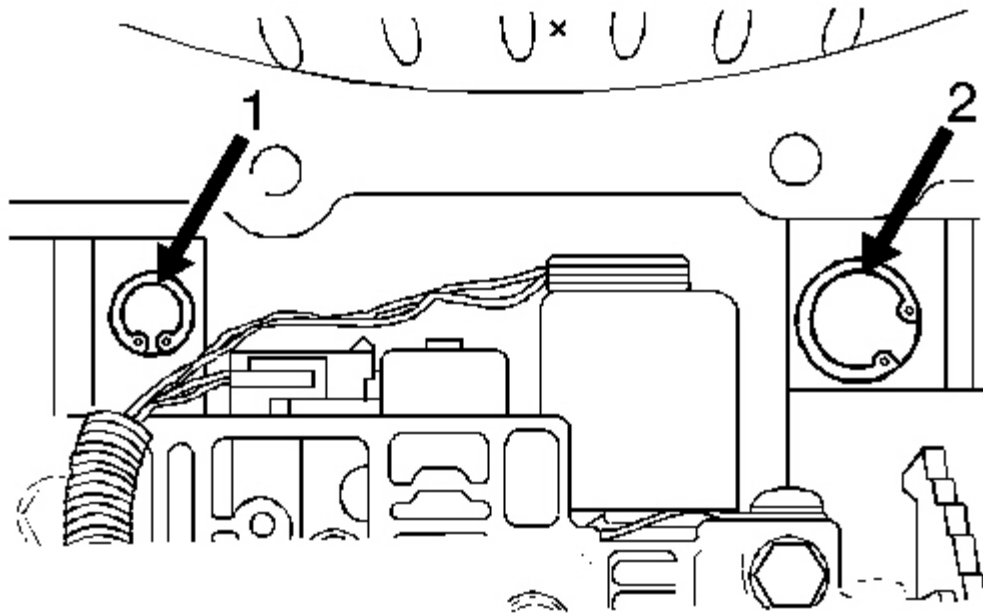

Fig. 97: View Of Valve Bore Plug Retainer Ring & Reverse Boost Valve Bushing Retainer Ring

Courtesy of GENERAL MOTORS CORP.

CAUTION: Valve springs can be tightly compressed. Use care when removing retainers and plugs. Personal injury could result.

8. Remove the TCC valve retainer ring (1).

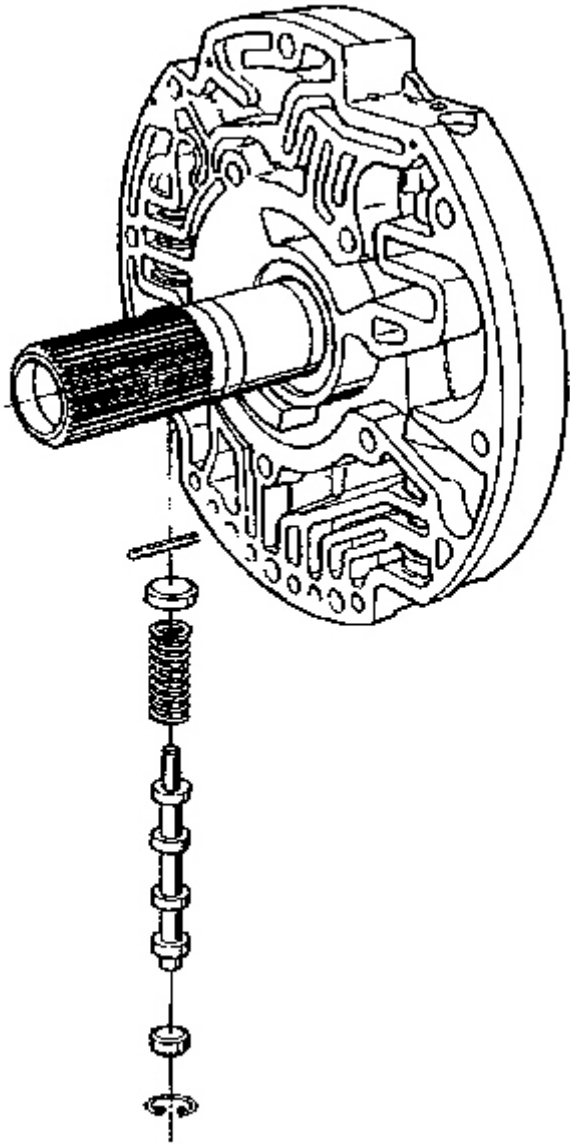

Fig. 98: TCC Valve Assembly
Courtesy of GENERAL MOTORS CORP.

9. Remove the following parts:
 - The valve bore plug

- The TCC valve
- The TCC valve spring(s)

Installation Procedure

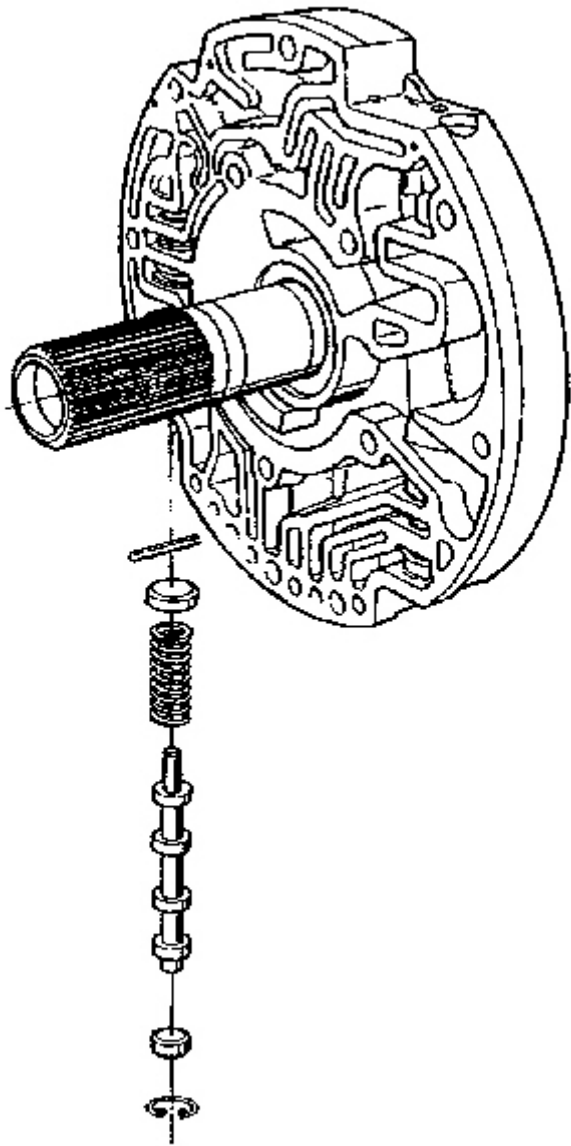

Fig. 99: TCC Valve Assembly

Courtesy of GENERAL MOTORS CORP.

IMPORTANT:

- Clean and inspect the TCC solenoid O-ring for cuts, nicks and damage. Replace if necessary.
- Inspect the TCC bore for sediment and debris. Flush the bore if necessary.
- Clean and inspect the TCC valve for binding, scoring and damage.
- Inspect the TCC spring for cracks and deformed or broken coils.

1. Install the following parts:

- The TCC valve spring
- The TCC valve
- The valve bore plug

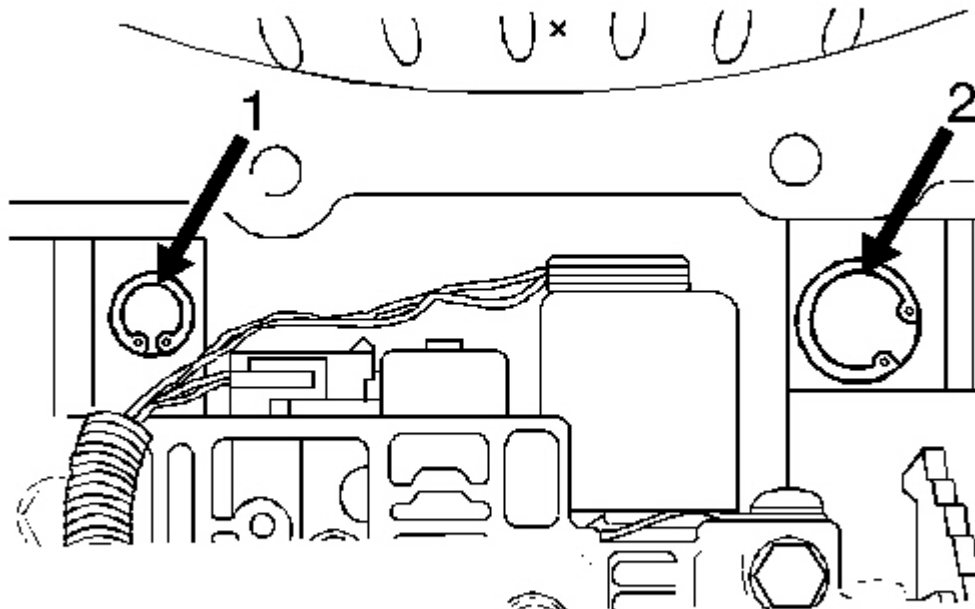

Fig. 100: View Of Valve Bore Plug Retainer Ring & Reverse Boost Valve Bushing

Retainer Ring

Courtesy of GENERAL MOTORS CORP.

2. Install the TCC valve retainer ring (1).
3. Install the TCC control solenoid.
4. Install the TCC control solenoid retaining bolts.

Tighten: Tighten the bolts to 8-14 N.m (71-124 lb in).

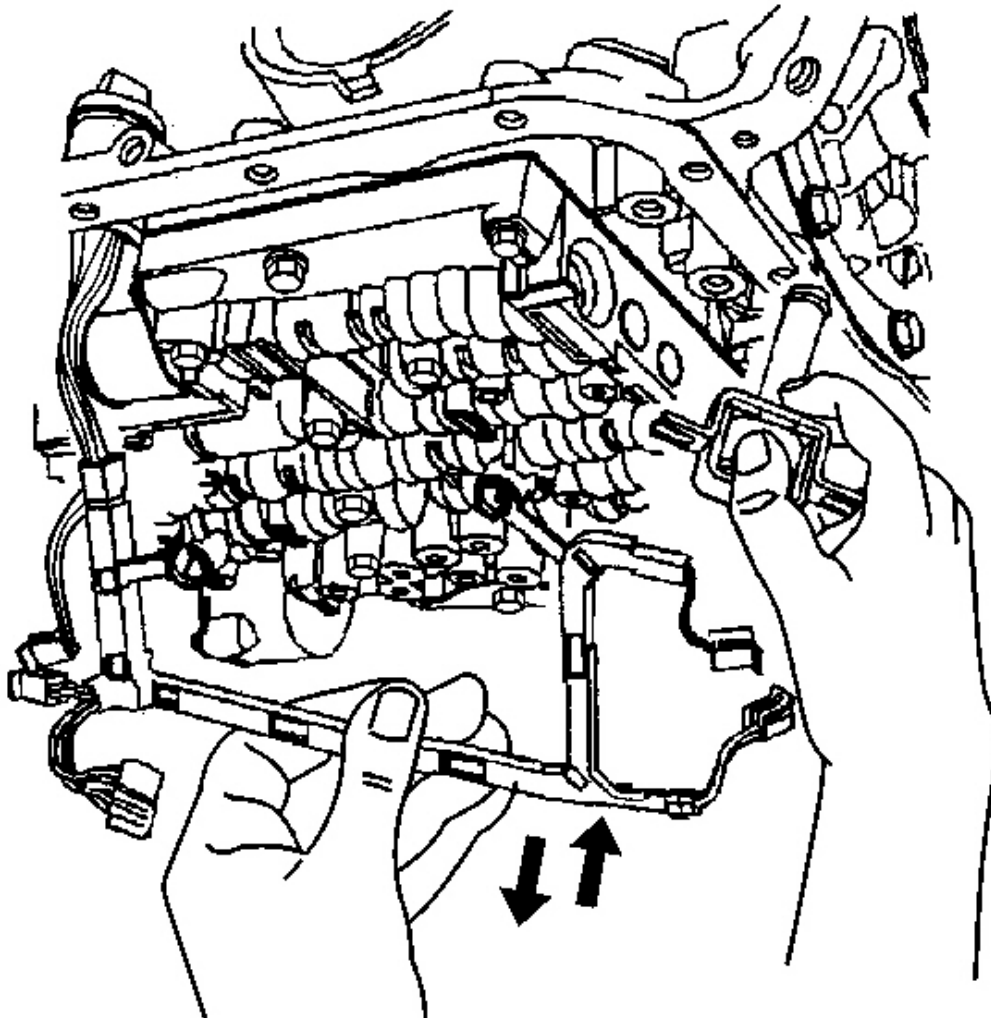

Fig. 101: View Of TCC Solenoid & Wiring Harness
Courtesy of GENERAL MOTORS CORP.

5. Connect the TCC control solenoid connector.
6. Install the TCC PWM solenoid.
7. Install the TCC PWM solenoid retainer.

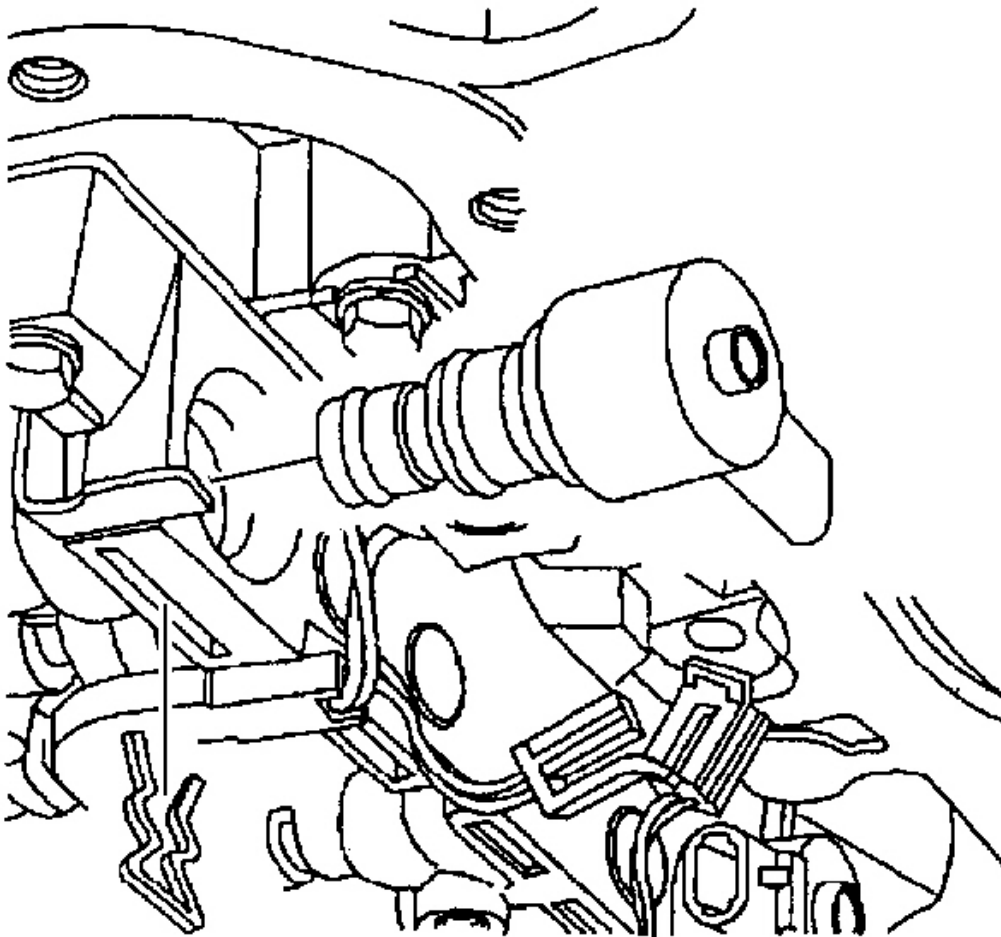

Fig. 102: View Of TCC PWM Solenoid & Retainer
Courtesy of GENERAL MOTORS CORP.

8. Connect the TCC PWM Solenoid electrical connector.

9. Install the transmission filter. Refer to Automatic Transmission Fluid and Filter Replacement.

TRANSMISSION FLUID FILLER TUBE AND SEAL REPLACEMENT

Removal Procedure

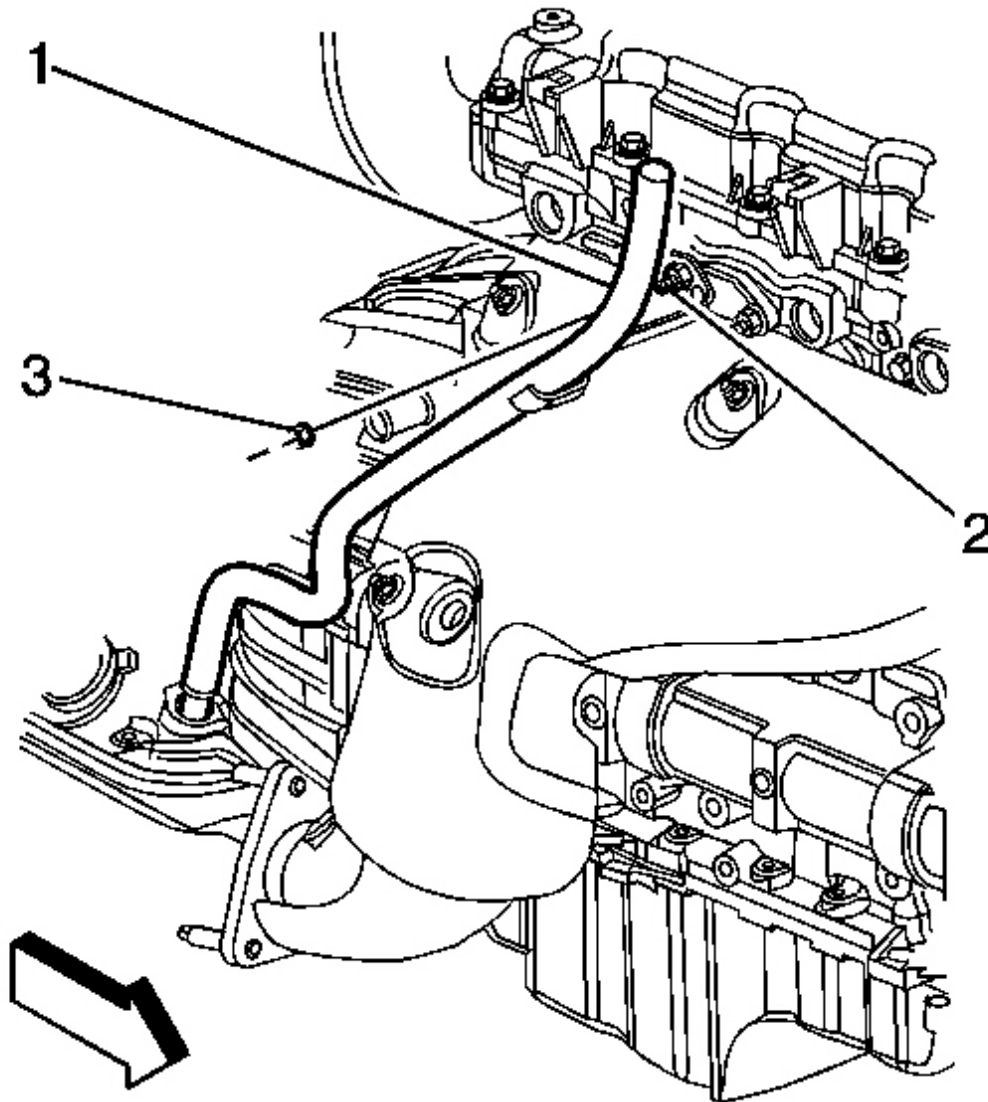

Fig. 103: View Of Filler Tube
Courtesy of GENERAL MOTORS CORP.

1. Remove the filler tube indicator.
2. Remove the nut (3) securing the filler tube to the secondary air injection (AIR) stud (2).
3. Raise and support the vehicle. Refer to **Lifting and Jacking the Vehicle** .
4. Clean away all dirt and debris from the transmission filler tube area.
5. Position an appropriate container under the transmission.
6. Remove the filler tube (1) and seal (2) from the transmission.

Allow the transmission fluid to drain into the container.

Installation Procedure

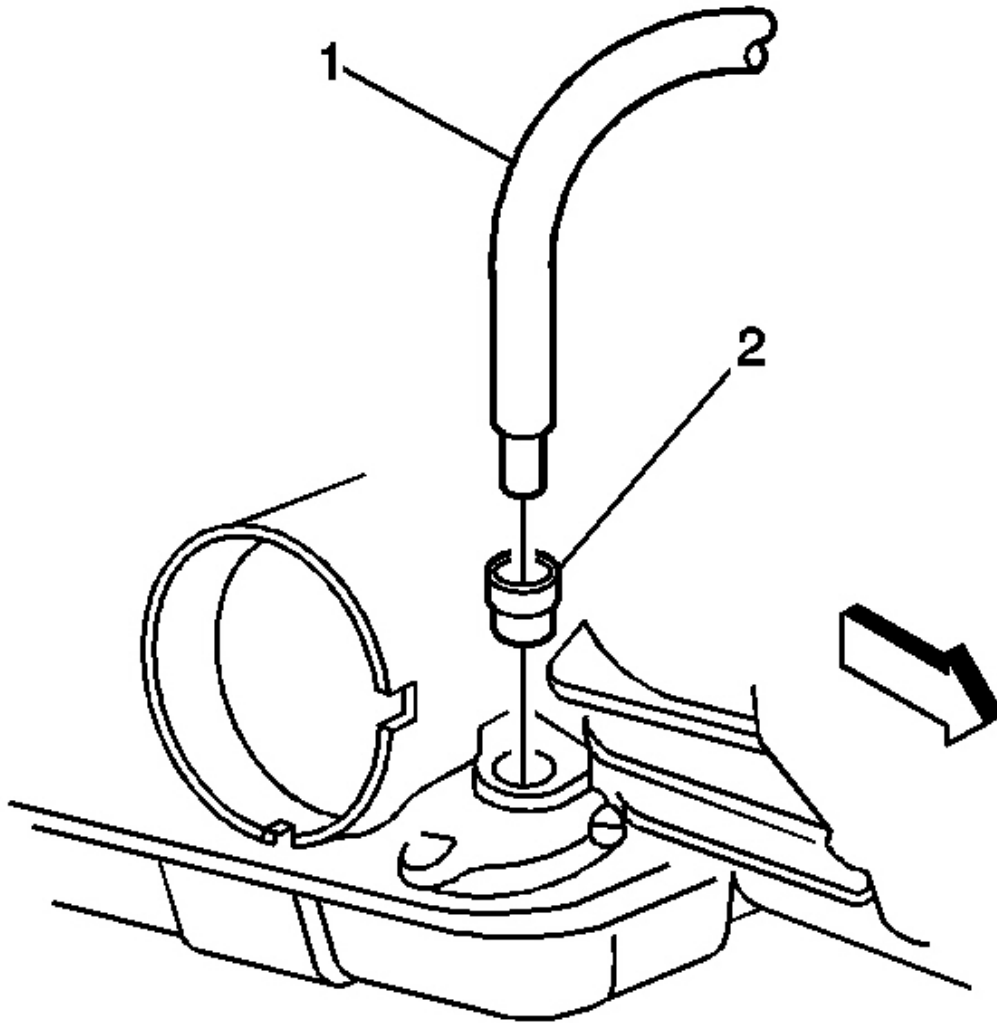

Fig. 104: Removing/Installing Filler Tube & Seal
Courtesy of GENERAL MOTORS CORP.

1. Install a new seal (2) into the transmission case.
2. Remove the container used to catch the used transmission fluid from under the vehicle.
3. Lightly lubricate the filler tube (1) and seal (2) with clean DEXRON® VI transmission fluid to ease installation.
4. Install the filler tube (1) into the seal (2).

5. Lower the vehicle.

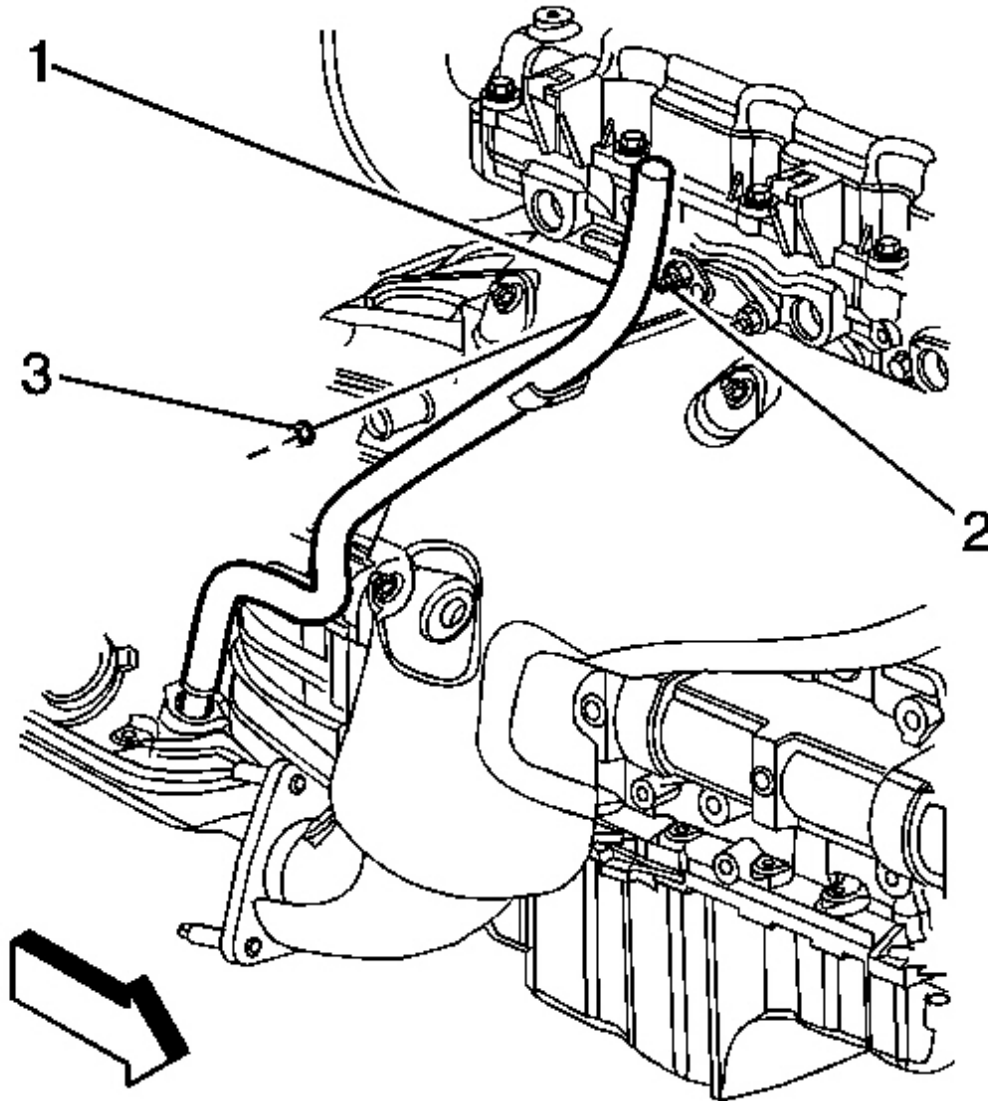

Fig. 105: View Of Filler Tube
Courtesy of GENERAL MOTORS CORP.

NOTE: Refer to Fastener Notice .

2007 Hummer H3

2007 TRANSMISSION Automatic Transmission - 4L60-E/4L65-E/4L70-E - H3

6. Install the nut (3) securing the filler tube (1) to the AIR stud (2).

Tighten: Tighten the filler tube nut to 12.5 N.m (111 lb in).

7. Install the filler tube indicator.

8. Fill the transmission to the proper level with DEXRON® VI transmission fluid. Refer to **Transmission Fluid Check**.

MANUAL SHIFT SHAFT SEAL REPLACEMENT

Tools Required

- **J 43909** Selector Shaft Seal Installer. See **Special Tools**.
- **J 43911** Selector Shaft Seal Remover. See **Special Tools**.

Removal Procedure

1. Remove the park/neutral back up switch. Refer to **Park/Neutral Backup Switch Replacement**.

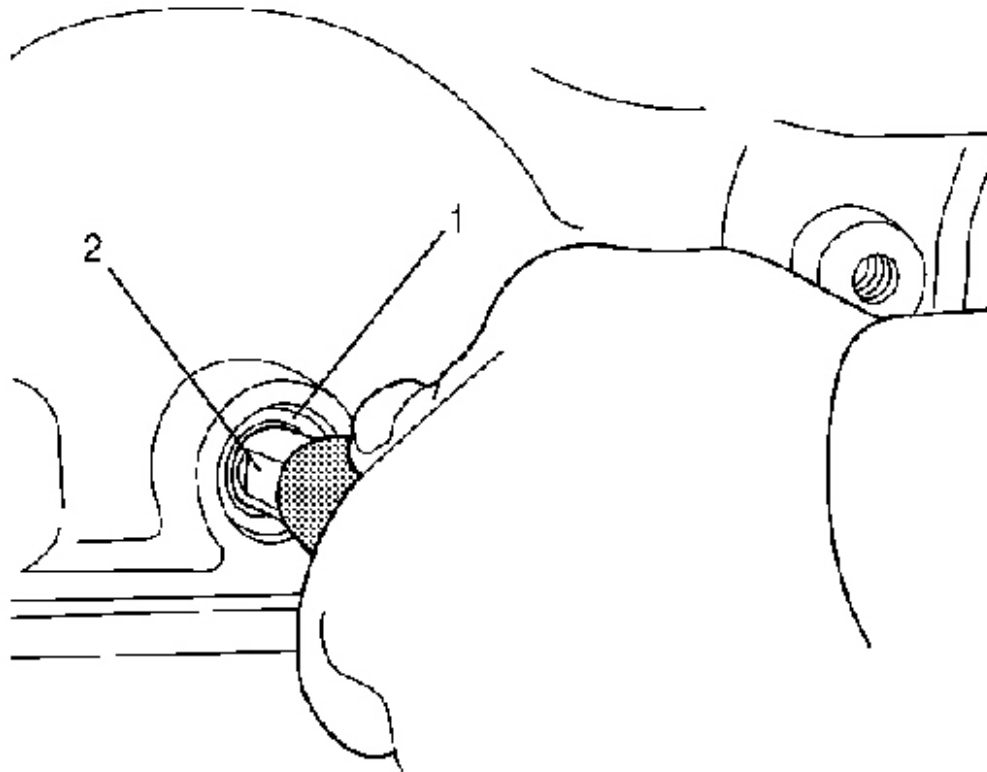

Fig. 106: Sliding Seal Remover Tool Over Selector Shaft
Courtesy of GENERAL MOTORS CORP.

2. Be sure that the jackscrew for the **J 43911** is backed off and will not interfere with installation of the removal tool. See **Special Tools**. Slide the seal remover tool over the selector shaft (2) with the threaded end of the tool towards the seal.
3. Rotate the removal tool so that the threads on the end of the tool engage the steel shell (1) of the seal. Use a wrench to be sure that the removal tool is firmly attached to the seal shell.
4. Rotate the jackscrew in the clockwise direction to remove the seal from the bore. Discard the seal that was removed.

Installation Procedure

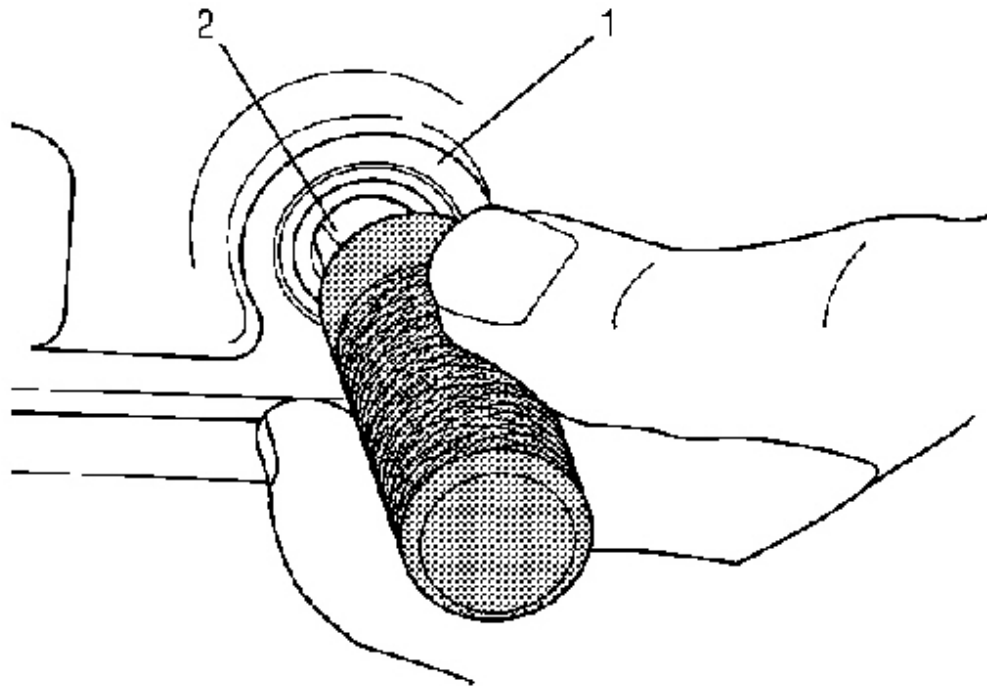

Fig. 107: Sliding New Selector Shaft Seal Over Selector Shaft
Courtesy of GENERAL MOTORS CORP.

1. Carefully slide a new selector shaft seal (1) over the selector shaft (2) with the wide face of the steel case facing outward. Position the seal so that it is starting to enter the seal bore.
2. Obtain the **J 43909** and remove the inner sleeve so that the tool will slide over the selector shaft. See **Special Tools**.
3. Slide the **J 43909** into position so that the end of the tool contacts the seal being installed. See **Special Tools**. Use a mallet to strike the **J 43909** and drive the new seal into the seal bore until it is seated at the bottom of the bore.
4. Install the park/neutral back up switch. Refer to **Park/Neutral Backup Switch Replacement**.
5. Fill the transmission to the proper level with DEXRON® VI transmission fluid. Refer to **Transmission Fluid Check**.

Removal Procedure

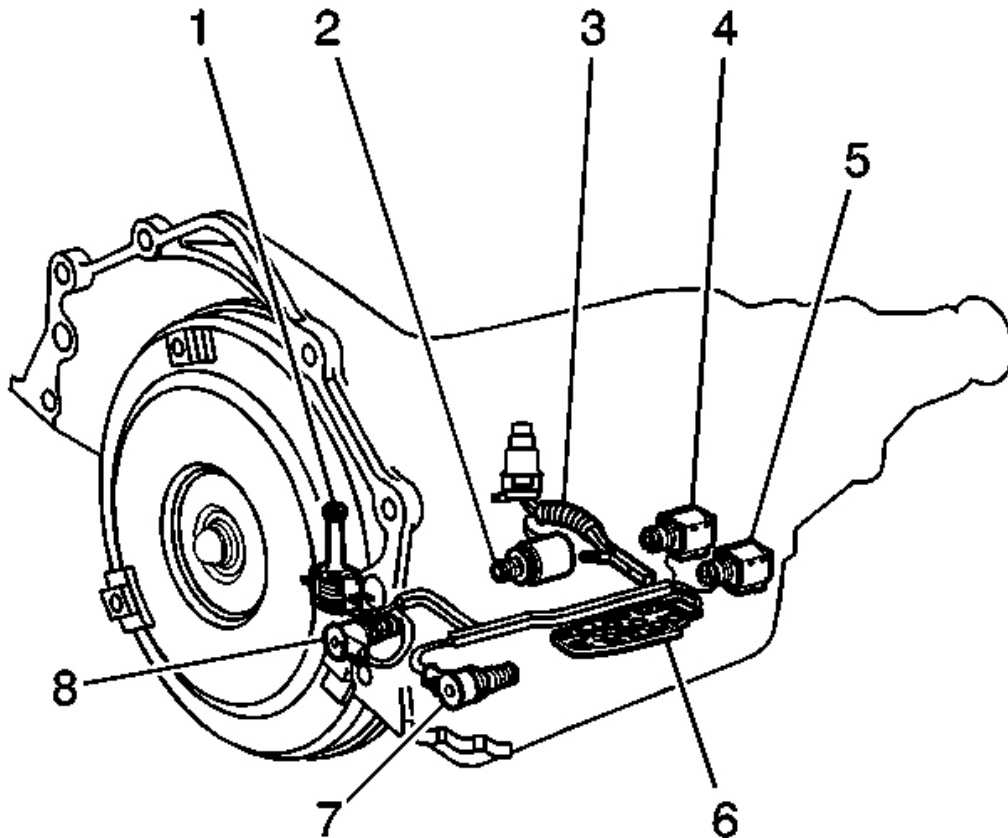

Fig. 108: Identifying Valve Body Electrical Components
Courtesy of GENERAL MOTORS CORP.

1. Ensure that removal of the valve body is necessary before proceeding.

IMPORTANT: The following components can be serviced without removing the valve body from the transmission:

- The torque converter clutch (TCC) solenoid (1)
- The pressure control solenoid (2)
- The internal wiring harness (3)
- The 2-3 shift solenoid (4)

- The 1-2 shift solenoid (5)
 - The transmission fluid pressure (TFP) manual valve position switch (6)
 - The 3-2 shift solenoid (7)
 - The torque converter clutch pulse width modulation (TCC/PWM) solenoid (8)
2. Remove the fluid level indicator.
 3. Remove the oil pan and filter. Refer to **Automatic Transmission Fluid and Filter Replacement**.

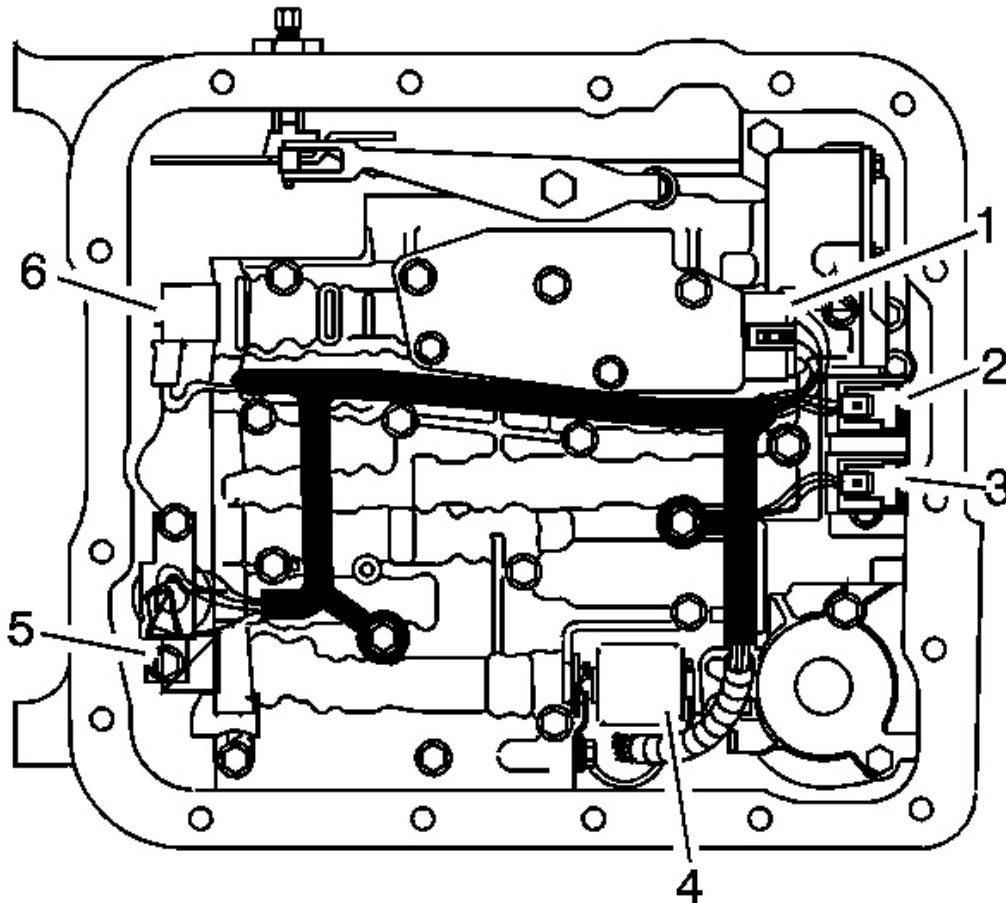

Fig. 109: Identifying Electrical Components In Valve Body
Courtesy of GENERAL MOTORS CORP.

4. Disconnect the internal wiring harness electrical connectors from the following components:

- The TFP manual valve position switch (1)
- The 1-2 shift solenoid (2)
- The 2-3 shift solenoid (3)
- The pressure control solenoid (4)
- The TCC/PWM solenoid (5)
- The 3-2 shift solenoid (6)

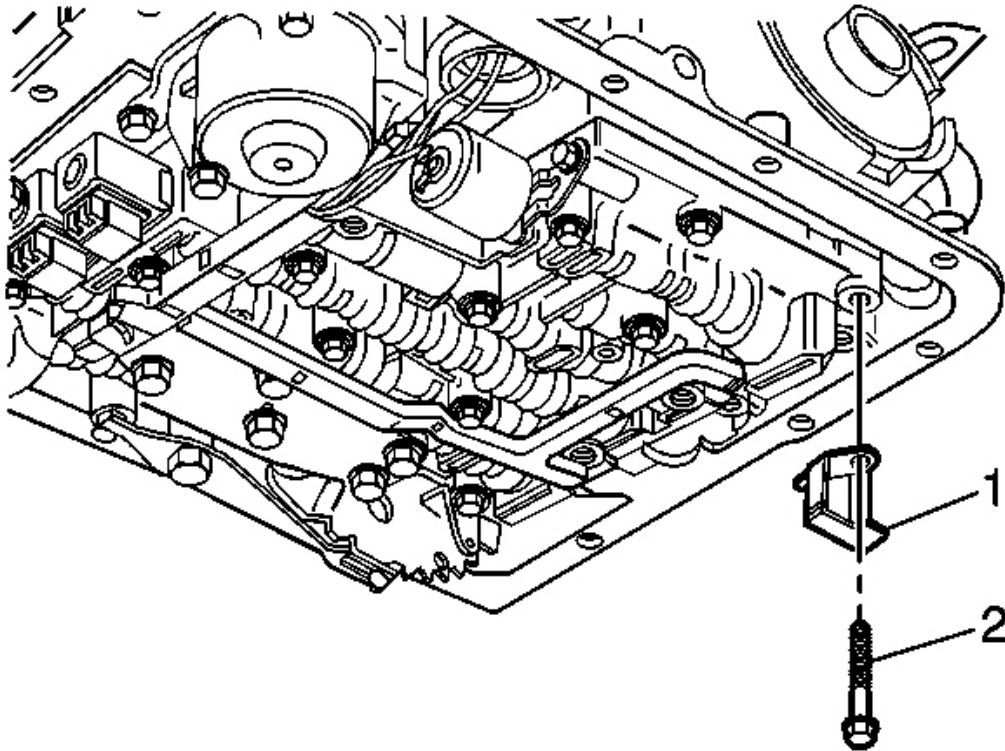

Fig. 110: Fluid Indicator Stop Bracket & Bolt
Courtesy of GENERAL MOTORS CORP.

5. RWD ONLY:

1. Remove the fluid indicator stop bracket bolt (2).
2. Remove the fluid indicator bracket (1).

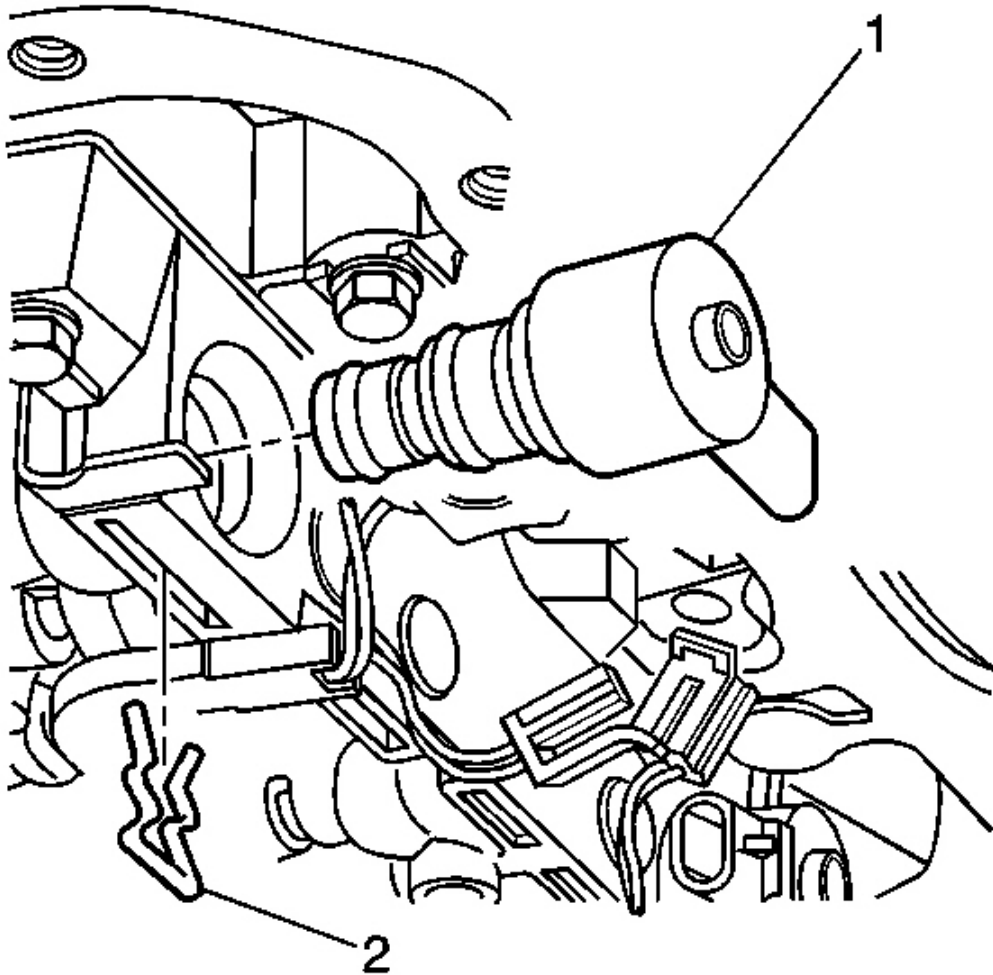

Fig. 111: View Of TCC PWM Solenoid & Retainer
Courtesy of GENERAL MOTORS CORP.

6. Remove the TCC/PWM solenoid retainer (2) with a small screwdriver. Rotate the solenoid (1) in the bore, if necessary, until the flat part of the retainer (2) is visible.
7. Remove the TCC/PWM solenoid (1) in order to access the TCC solenoid retaining bolts.

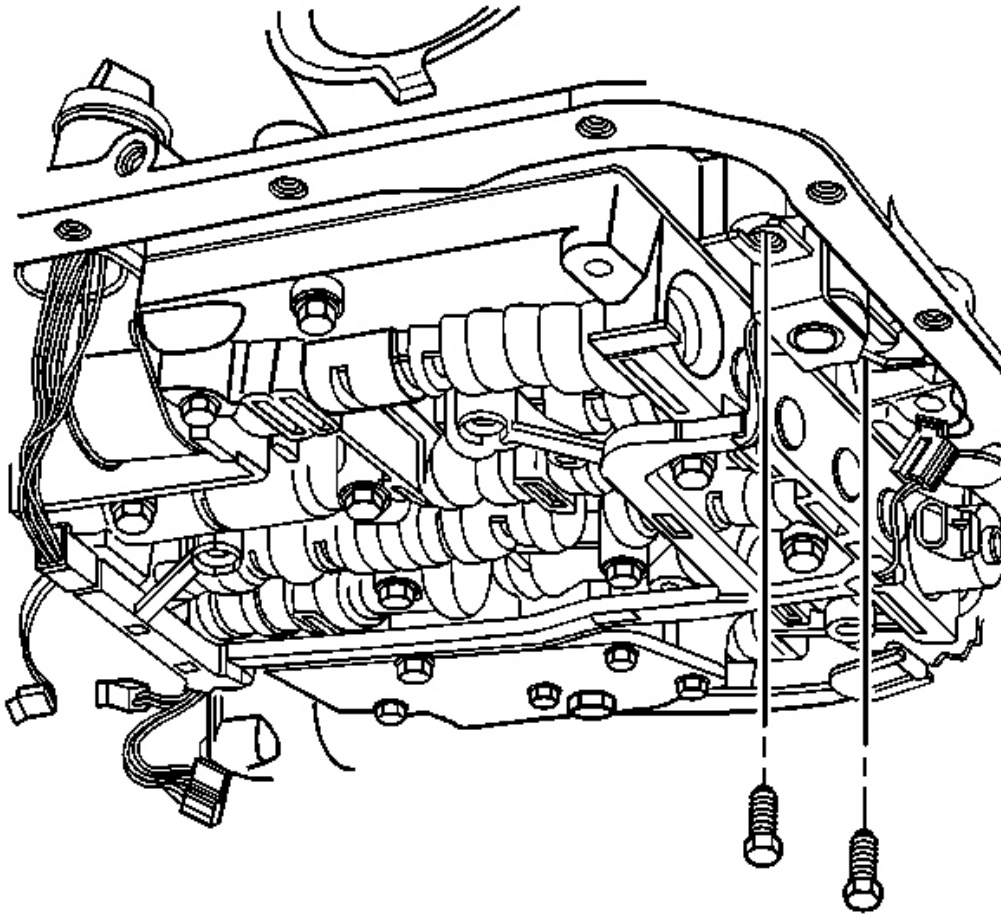

Fig. 112: View Of TCC Solenoid Retaining Bolts
Courtesy of GENERAL MOTORS CORP.

8. Remove the TCC solenoid retaining bolts.

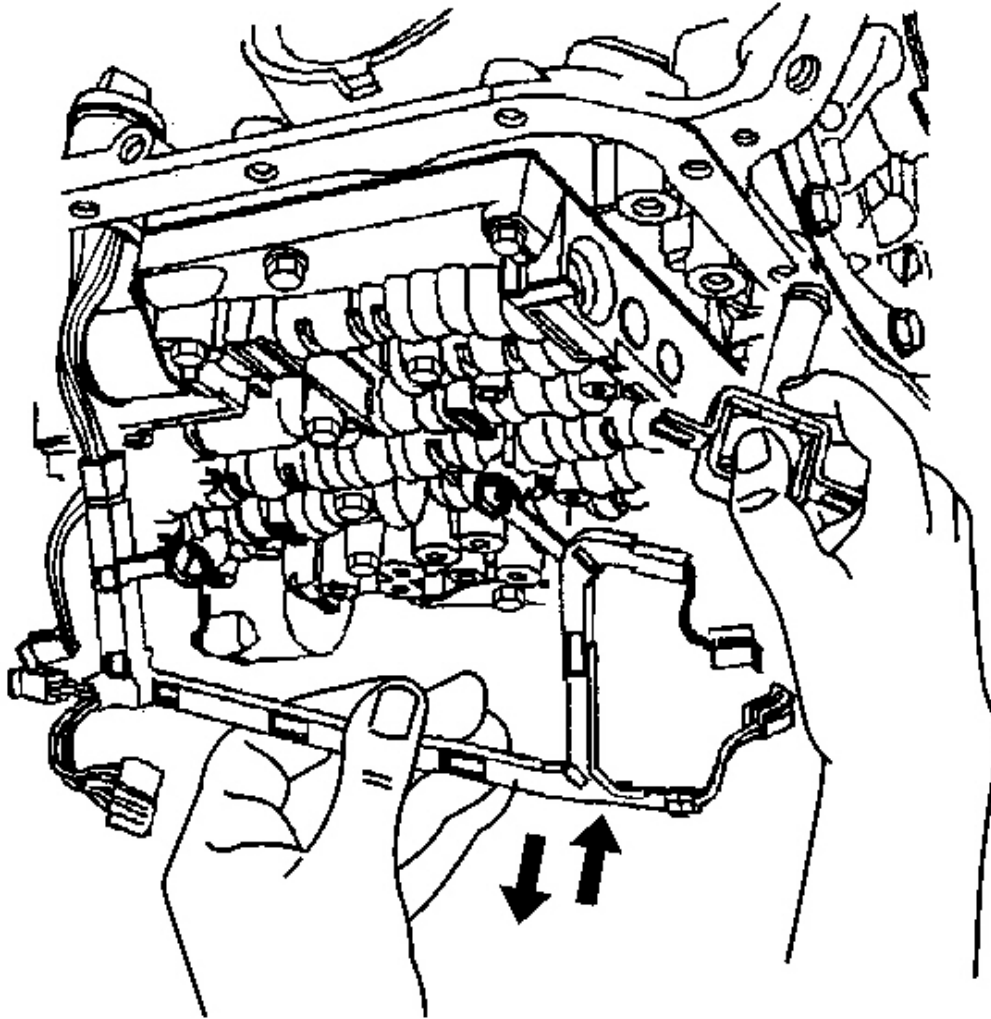

Fig. 113: View Of TCC Solenoid & Wiring Harness
Courtesy of GENERAL MOTORS CORP.

9. Remove the TCC solenoid with O-ring seal and wiring harness from the control valve body.
10. Reposition the harness to the side of the transmission case.

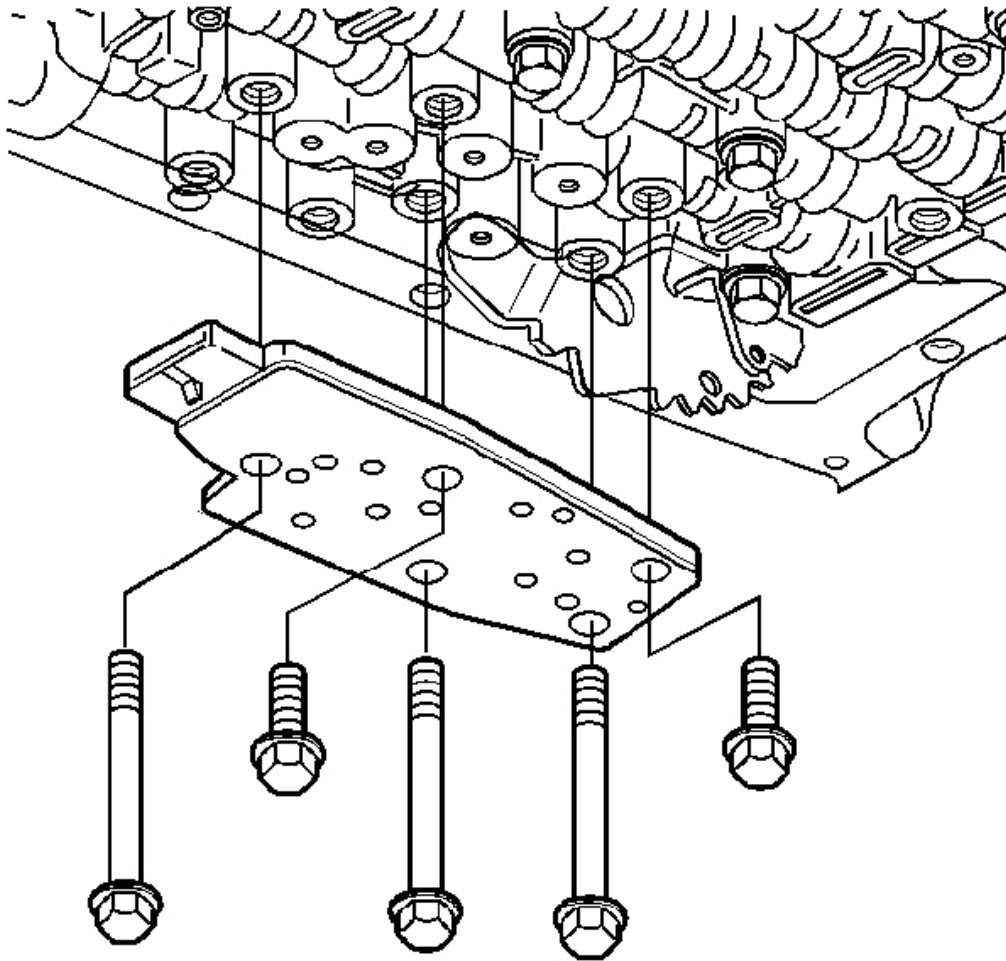

Fig. 114: View Of Transmission Fluid Pressure Switch & Bolts
Courtesy of GENERAL MOTORS CORP.

11. Remove the control valve body bolts securing the TFP manual valve position switch to the control valve body.
12. Remove the TFP manual valve position switch.

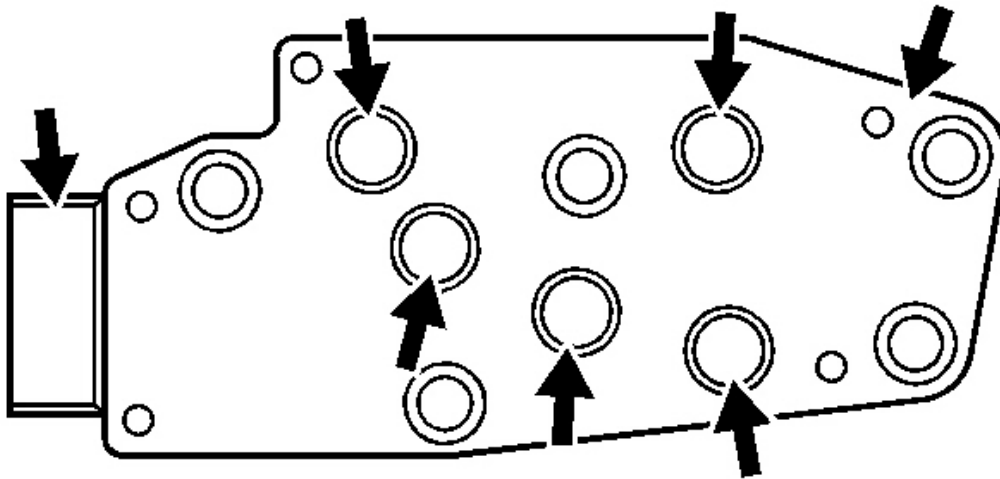

Fig. 115: Inspection Areas On Transmission Fluid Pressure (TFP) Manual Valve Position Switch Assembly
Courtesy of GENERAL MOTORS CORP.

13. Inspect the TFP manual valve position switch for the following conditions:
- Damage
 - Debris
 - Damaged or missing O-rings
 - Cracked connector
 - Loose electrical terminals
 - Poor terminal retention
 - Sediment in switch membrane

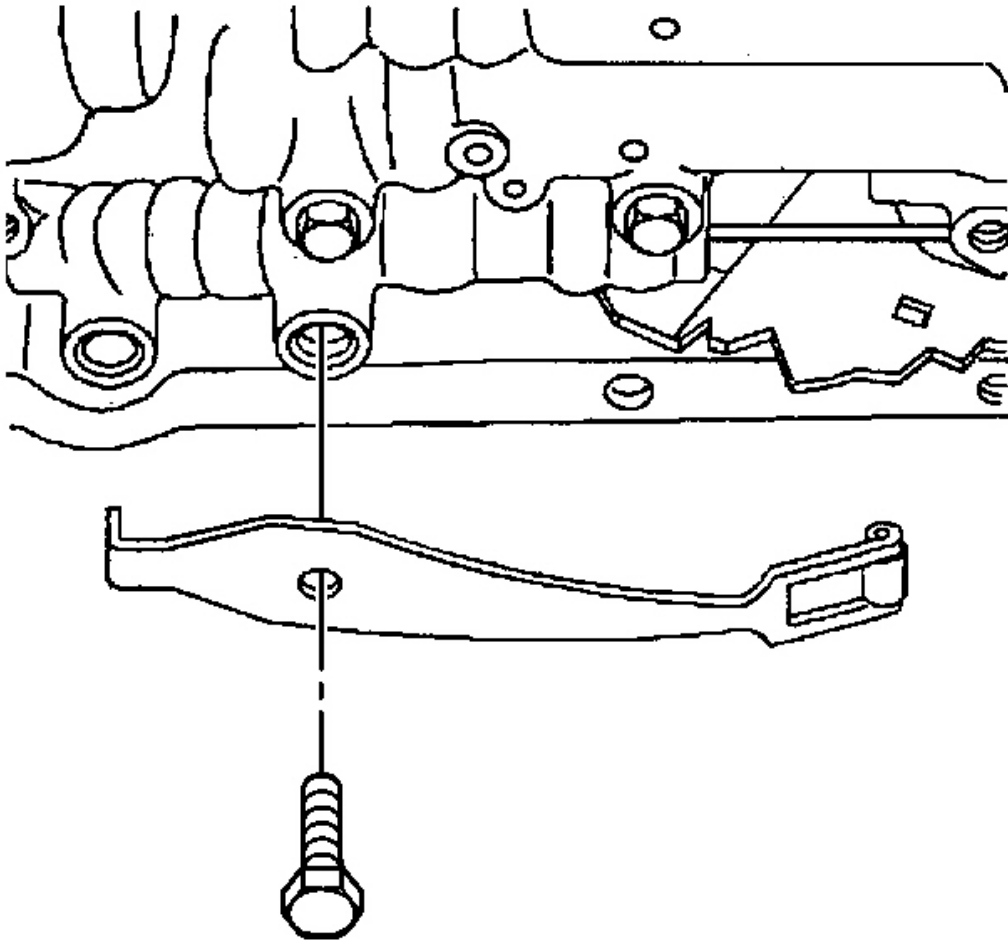

Fig. 116: Identifying Manual Detent Spring
Courtesy of GENERAL MOTORS CORP.

14. Remove the manual detent spring bolt.
15. Remove the manual detent spring.
16. Inspect the manual detent spring for cracks or damage.
17. Remove the remaining control valve body bolts.

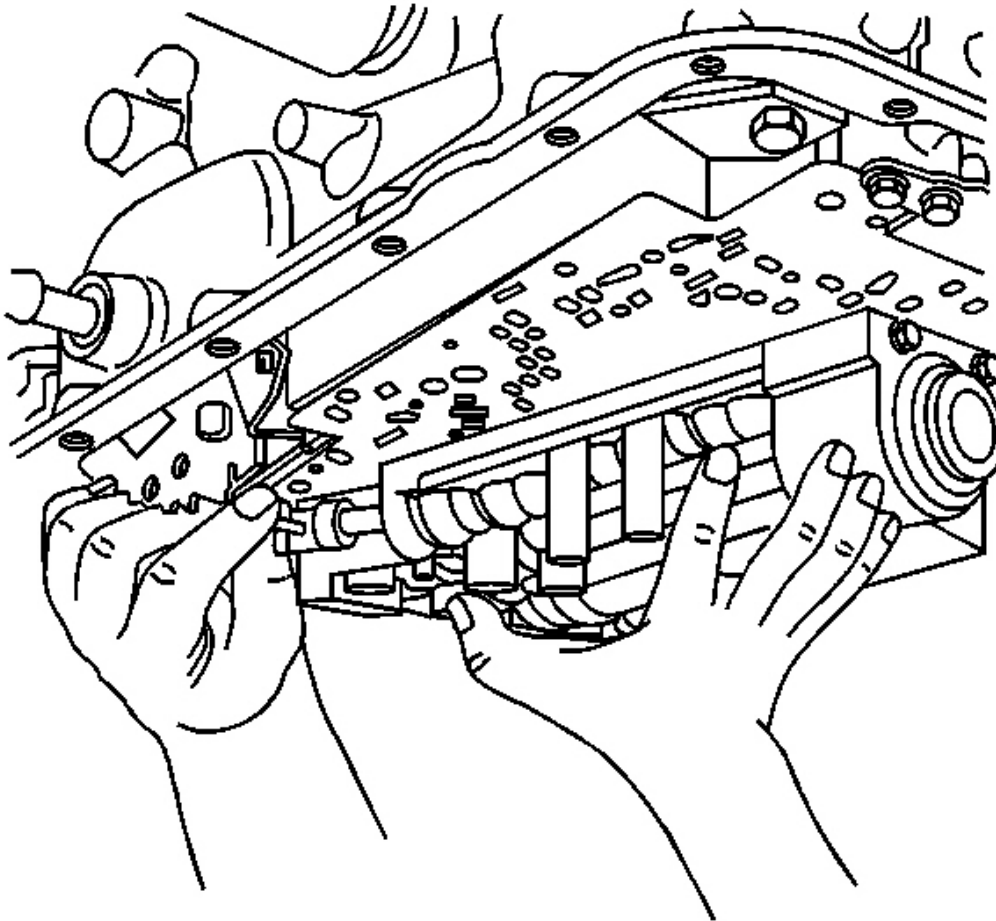

Fig. 117: View Of Valve Body To Transmission Case
Courtesy of GENERAL MOTORS CORP.

IMPORTANT: Keep the control valve body level when lowering it from the transmission case. This will prevent the loss of checkballs located in the control valve body passages.

18. Carefully begin to lower the control valve body down from the transmission case while simultaneously disconnecting the manual valve link from the manual valve.

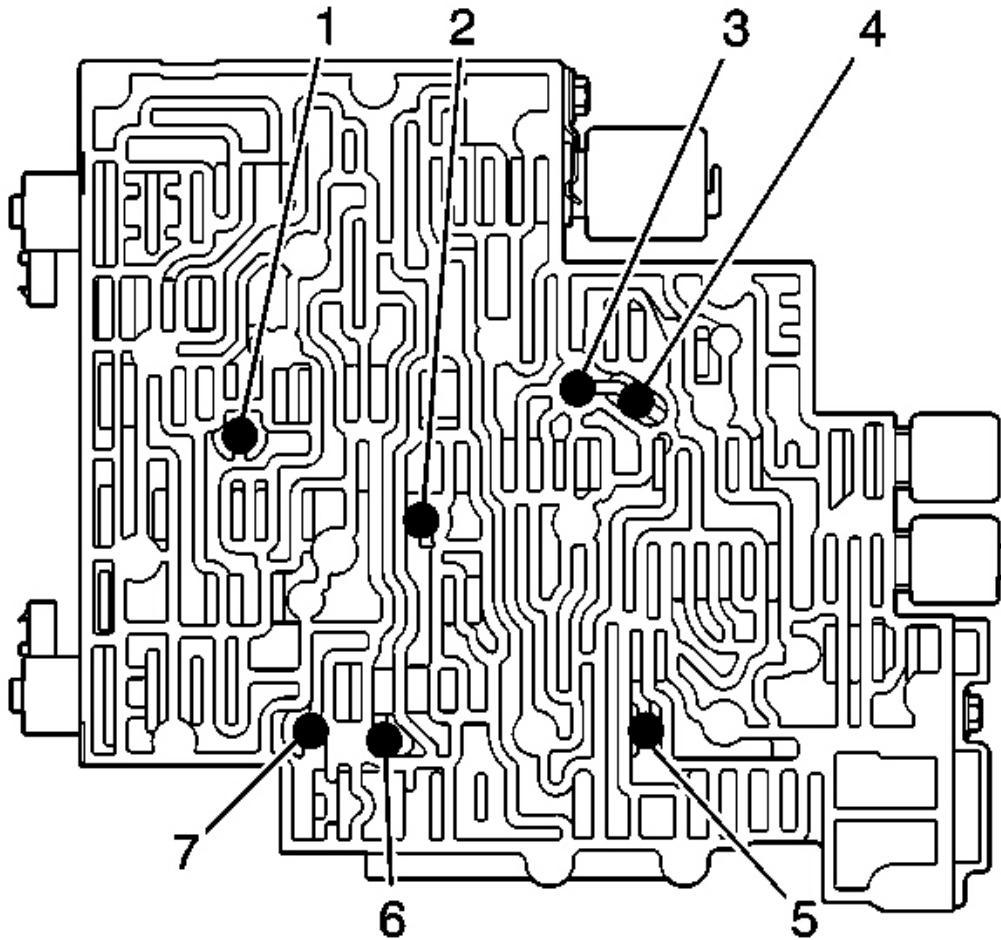

Fig. 118: Locating Valve Body Check Balls
Courtesy of GENERAL MOTORS CORP.

1. Install the checkballs (1-7) in the valve body.

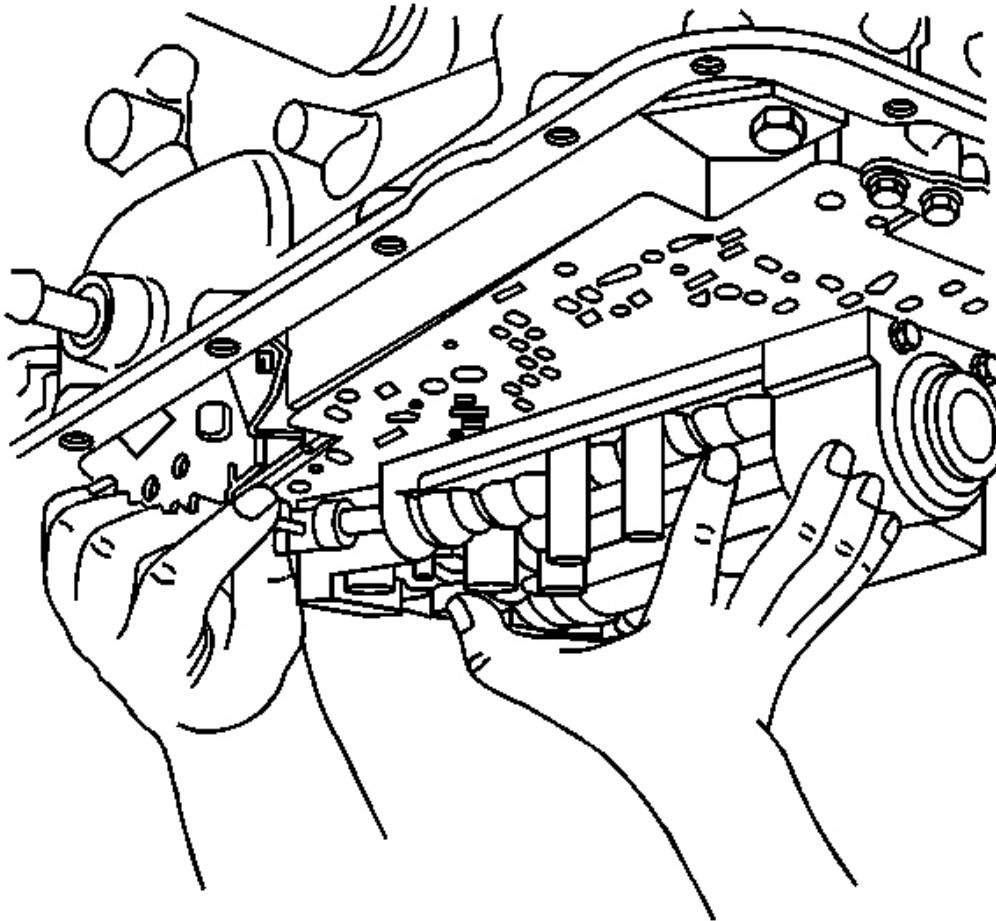

Fig. 119: View Of Valve Body To Transmission Case
Courtesy of GENERAL MOTORS CORP.

IMPORTANT: Keep the control valve body level when raising it to the transmission case. This will prevent the loss of checkballs located in the control valve body passages.

2. Install the control valve body to the transmission case while simultaneously connecting the manual valve link to the manual valve.

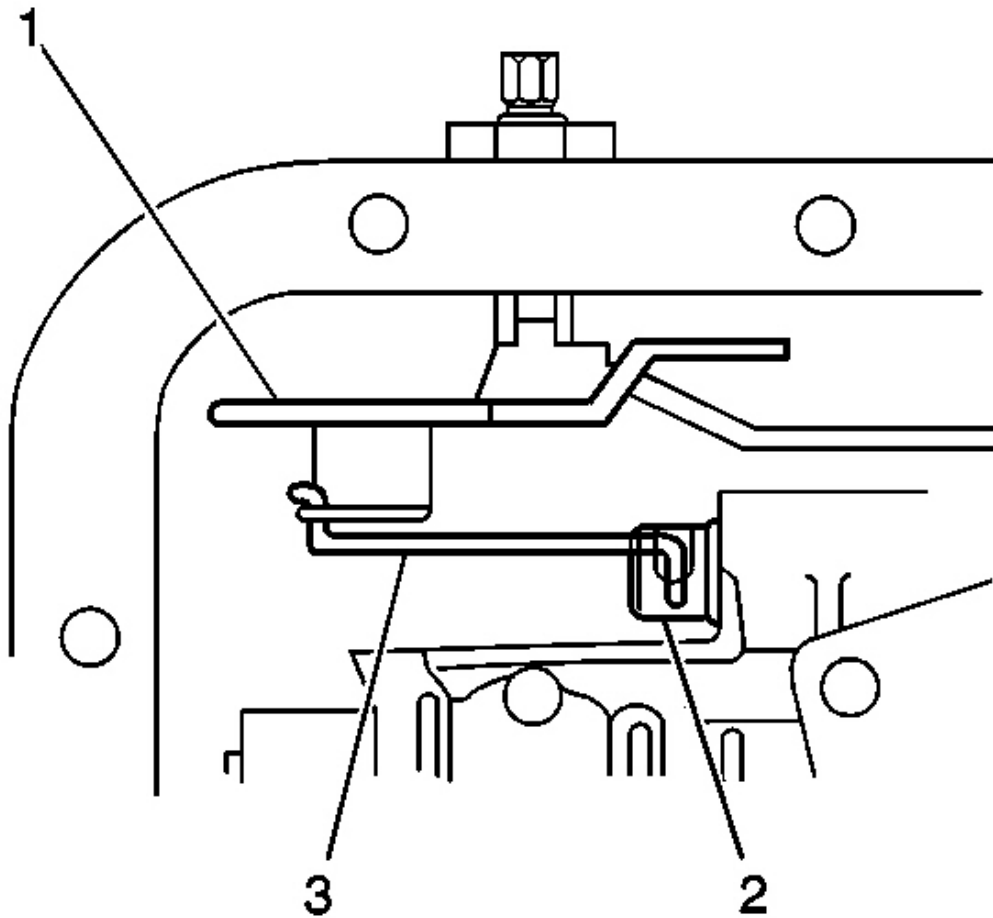

Fig. 120: Verifying Manual Valve Link Is Installed Properly To Inside Detent Lever & Manual Valve

Courtesy of GENERAL MOTORS CORP.

3. Verify that the manual valve link (3) is installed properly to the inside detent lever (1) and the manual valve (2).
4. Install one bolt (M6 X 1.0 X 47.5) hand tight in the center of the valve body to hold it in place.

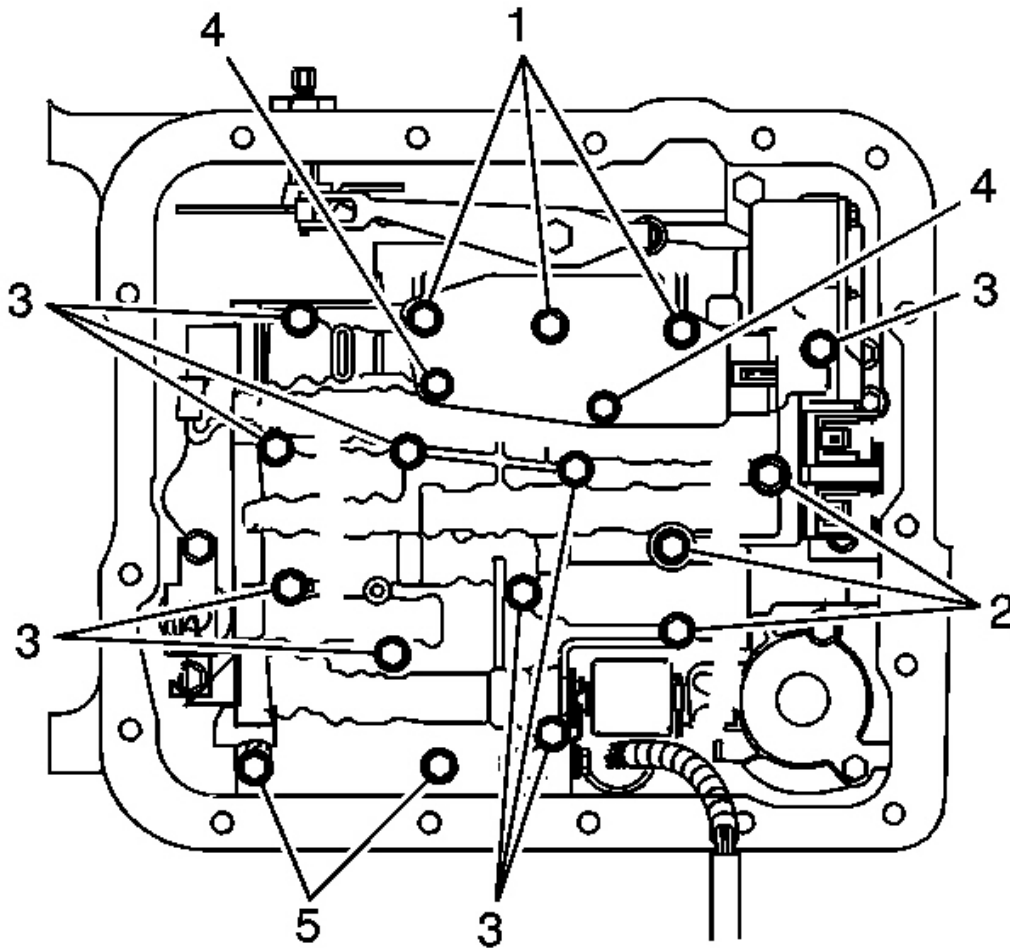

Fig. 121: Locating Valve Body Bolts
Courtesy of GENERAL MOTORS CORP.

IMPORTANT: When installing bolts throughout this procedure, be sure to use the correct bolt size and length in the correct location as specified.

5. Do not install the transmission fluid indicator stop bracket and bolt at this time, if equipped. Install but do not tighten the control valve body bolts securing only the valve body directly. Each numbered bolt location corresponds to a specific bolt size and length, as indicated by

the following:

- M6 X 1.0 X 65.0 (1)
- M6 X 1.0 X 54.4 (2)
- M6 X 1.0 X 47.5 (3)
- M6 X 1.0 X 17.7 (4)
- M6 X 1.0 X 35.0 (5)

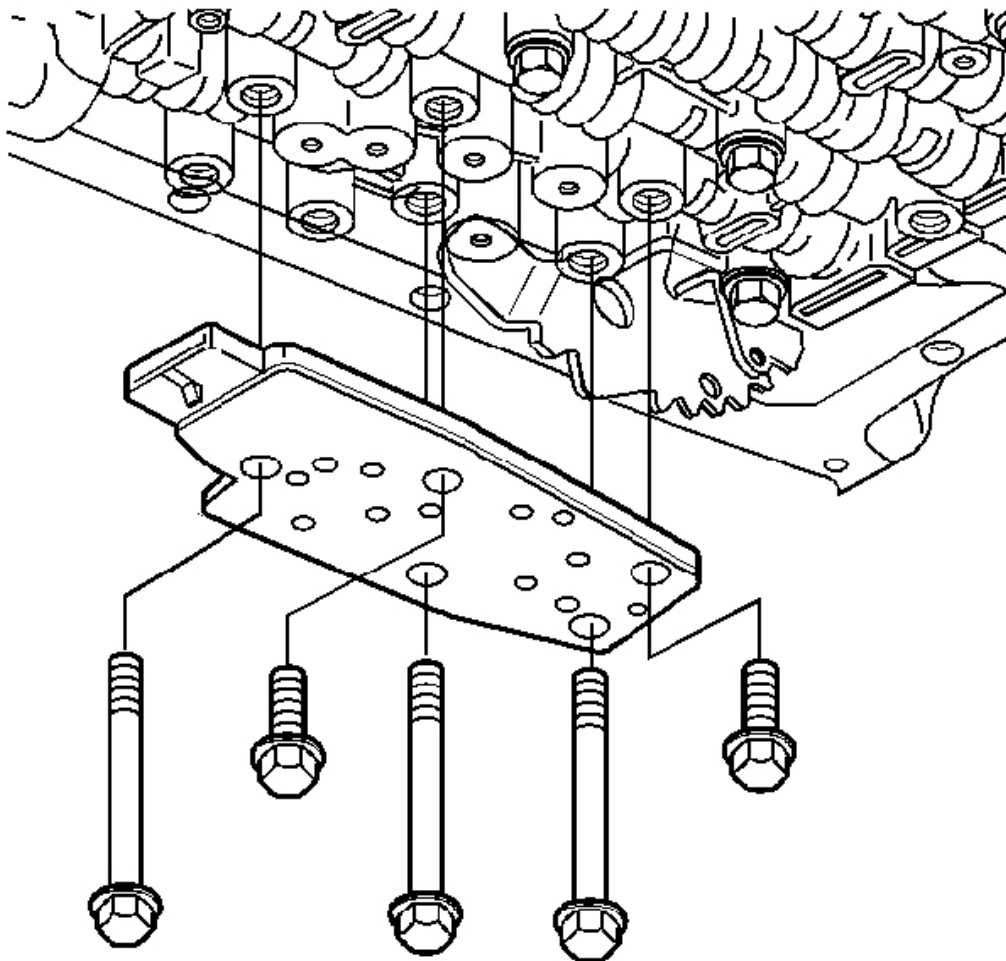

Fig. 122: View Of Transmission Fluid Pressure Switch & Bolts
Courtesy of GENERAL MOTORS CORP.

2007 Hummer H3

2007 TRANSMISSION Automatic Transmission - 4L60-E/4L65-E/4L70-E - H3

6. Install the TFP manual valve position switch.
7. Install but do not tighten the control valve body bolts securing the TFP manual valve position switch to the control valve body.

NOTE: Refer to Fastener Notice .

NOTE: Do not over-tighten the bolts. Over-tightening the bolts will distort the valve bores. Begin tightening from the center of the valve body tighten the bolts in a outward direction.

8. Tighten the control valve body bolts in a spiral pattern starting from the center and working outward.

Tighten: Tighten the control valve body bolts to 11 N.m (97 lb in).

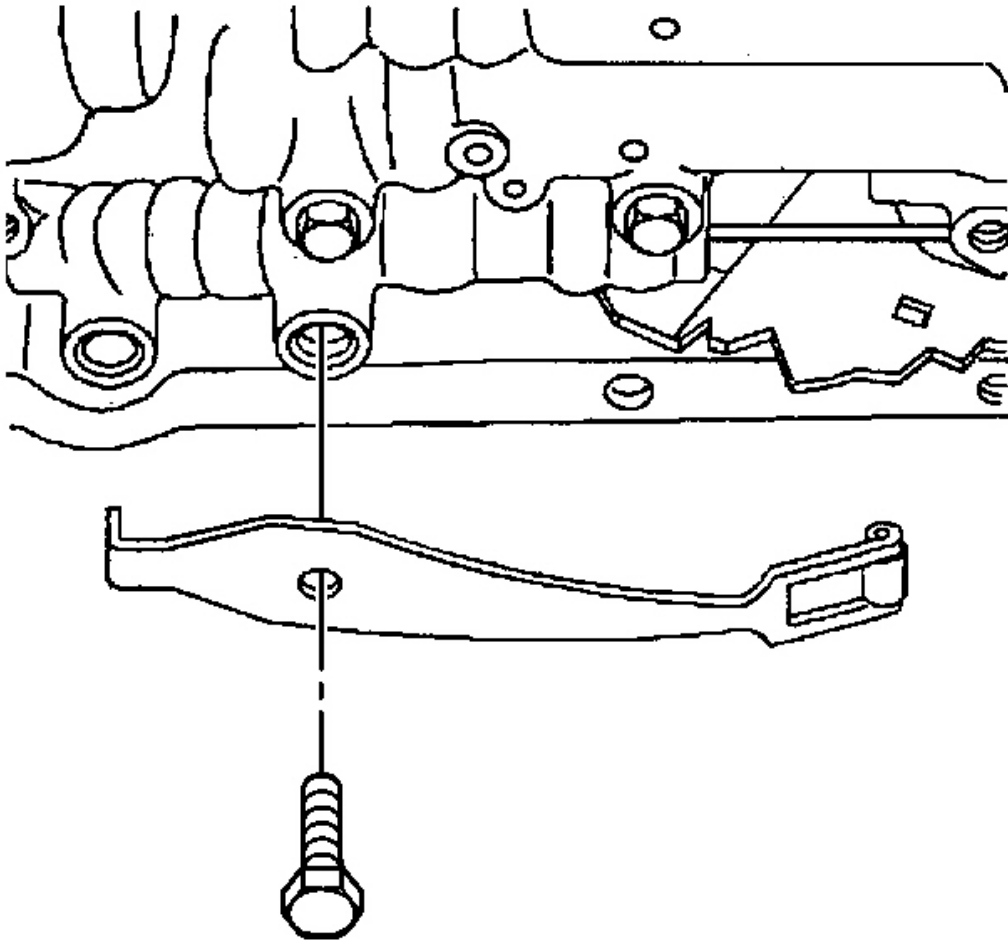

Fig. 123: Identifying Manual Detent Spring
Courtesy of GENERAL MOTORS CORP.

9. Install the manual detent spring and bolt.
10. Ensure that the manual detent spring is aligned properly with the detent lever.

Tighten: Tighten the manual detent spring bolt to 31 N.m (23 lb ft).

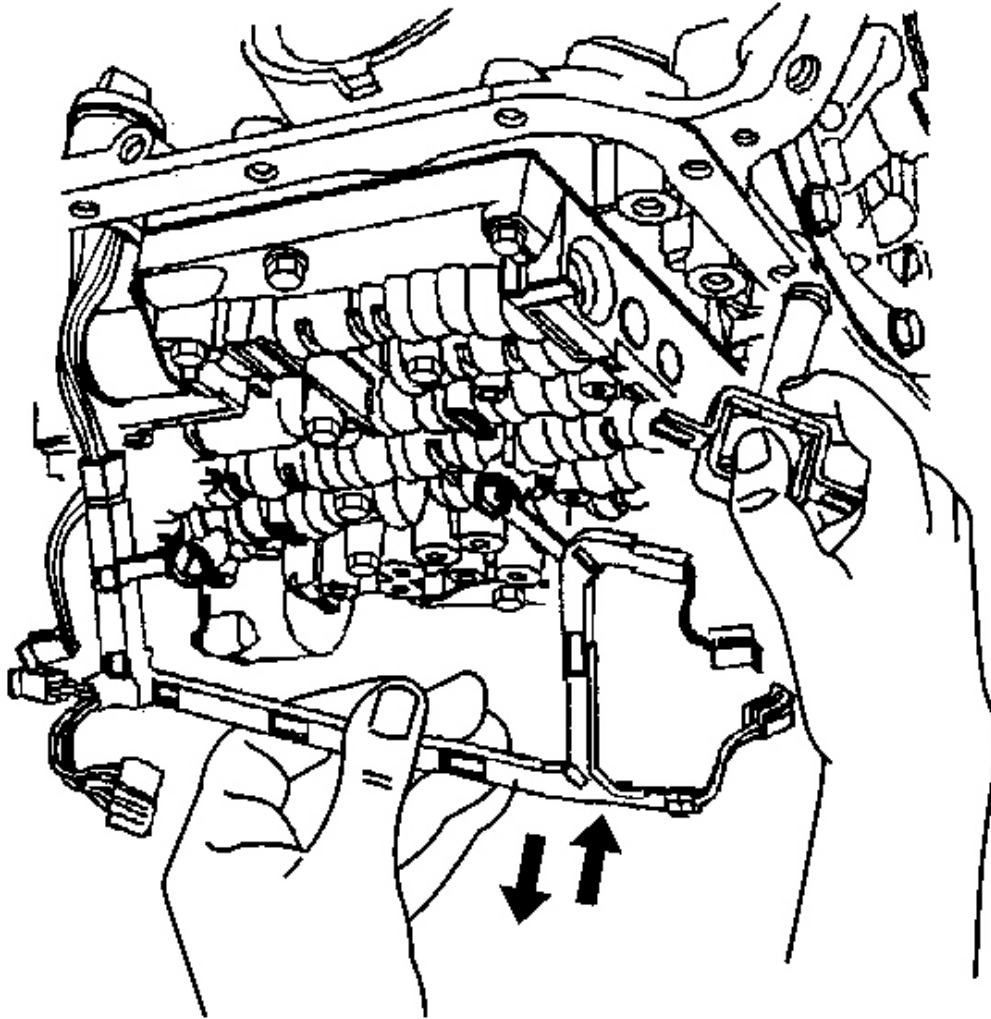

Fig. 124: View Of TCC Solenoid & Wiring Harness
Courtesy of GENERAL MOTORS CORP.

11. Install the TCC solenoid with a new O-ring seal to the valve body.

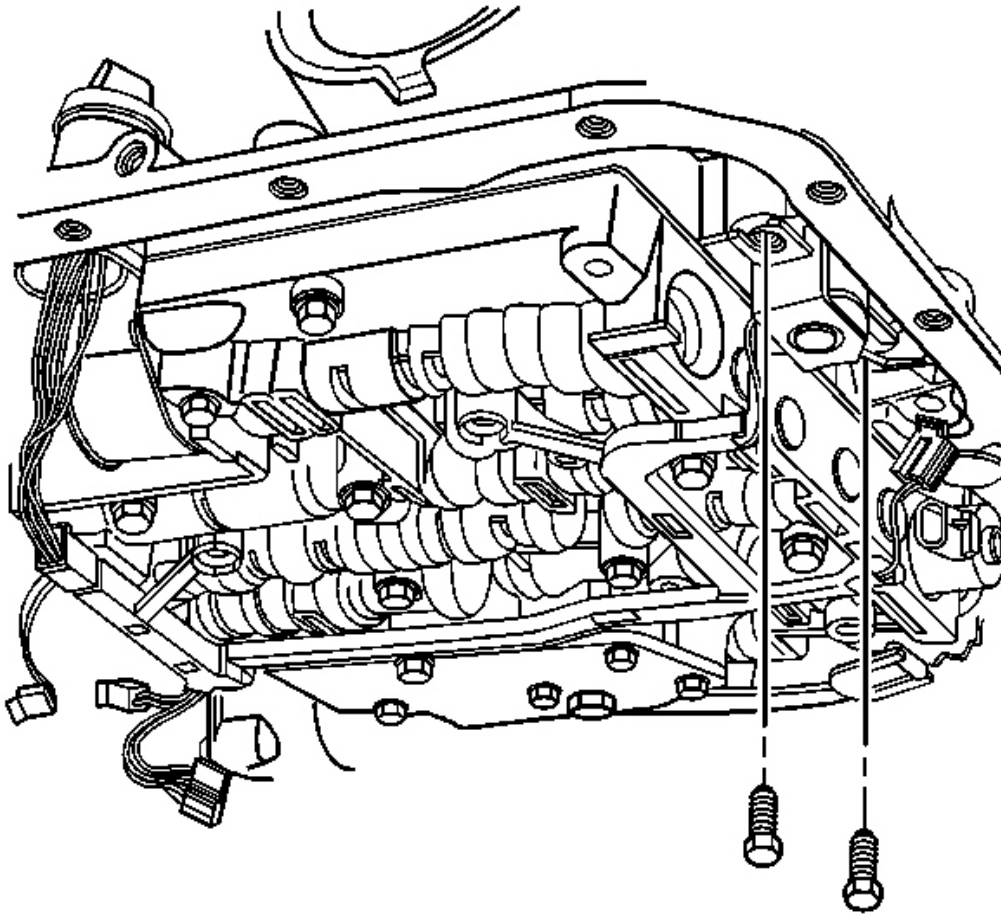

Fig. 125: View Of TCC Solenoid Retaining Bolts
Courtesy of GENERAL MOTORS CORP.

12. Install the TCC solenoid bolts.

Tighten: Tighten the TCC solenoid retaining bolts to 11 N.m (97 lb in).

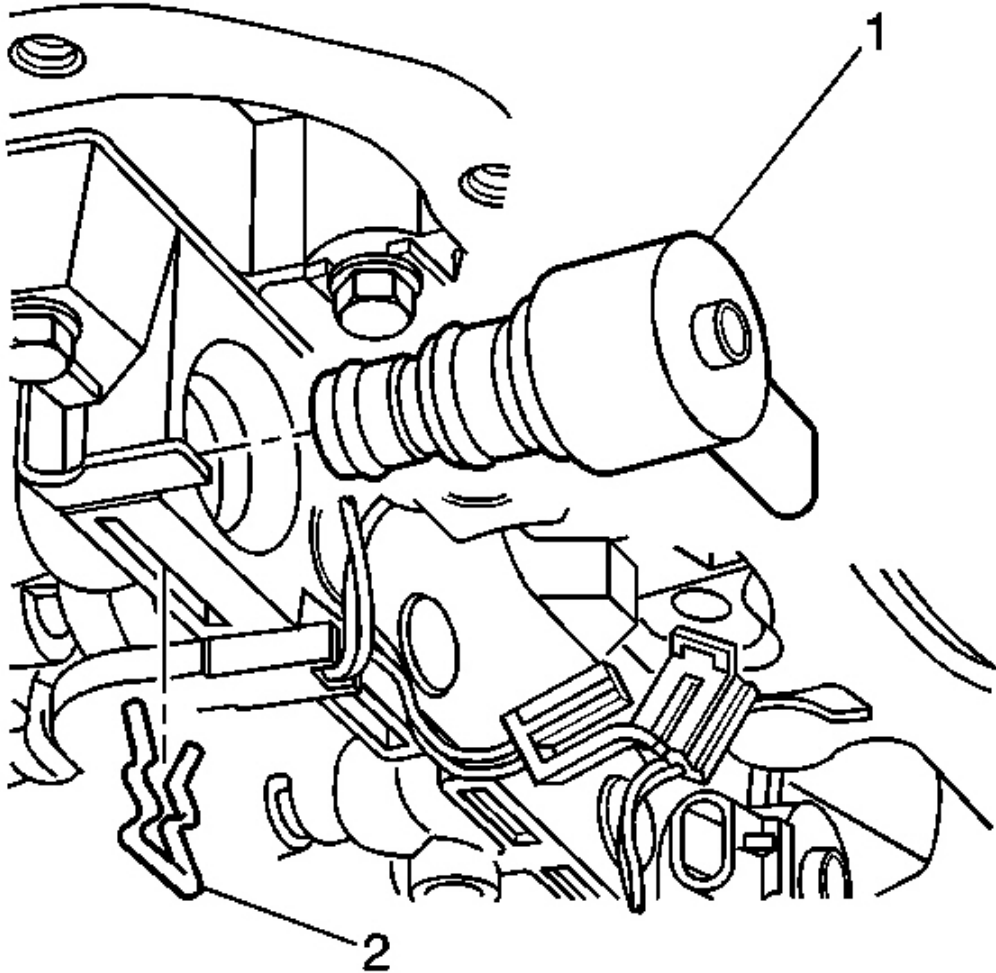

Fig. 126: View Of TCC PWM Solenoid & Retainer
Courtesy of GENERAL MOTORS CORP.

13. Install the TCC/PWM solenoid (1) to the control valve body.
14. Install the TCC/PWM solenoid retainer (2).

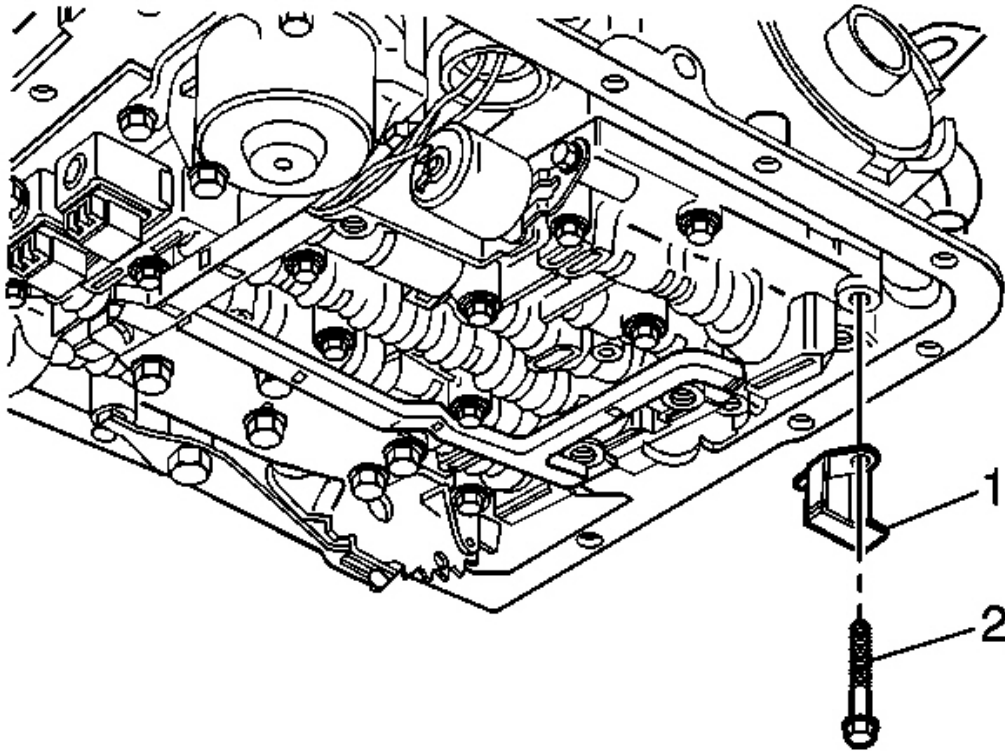

Fig. 127: Fluid Indicator Stop Bracket & Bolt
Courtesy of GENERAL MOTORS CORP.

15. RWD ONLY:

Install the transmission fluid indicator stop bracket (1) and bolt (2).

Tighten: Tighten the transmission fluid indicator stop bracket bolt to 11 N.m (97 lb in).

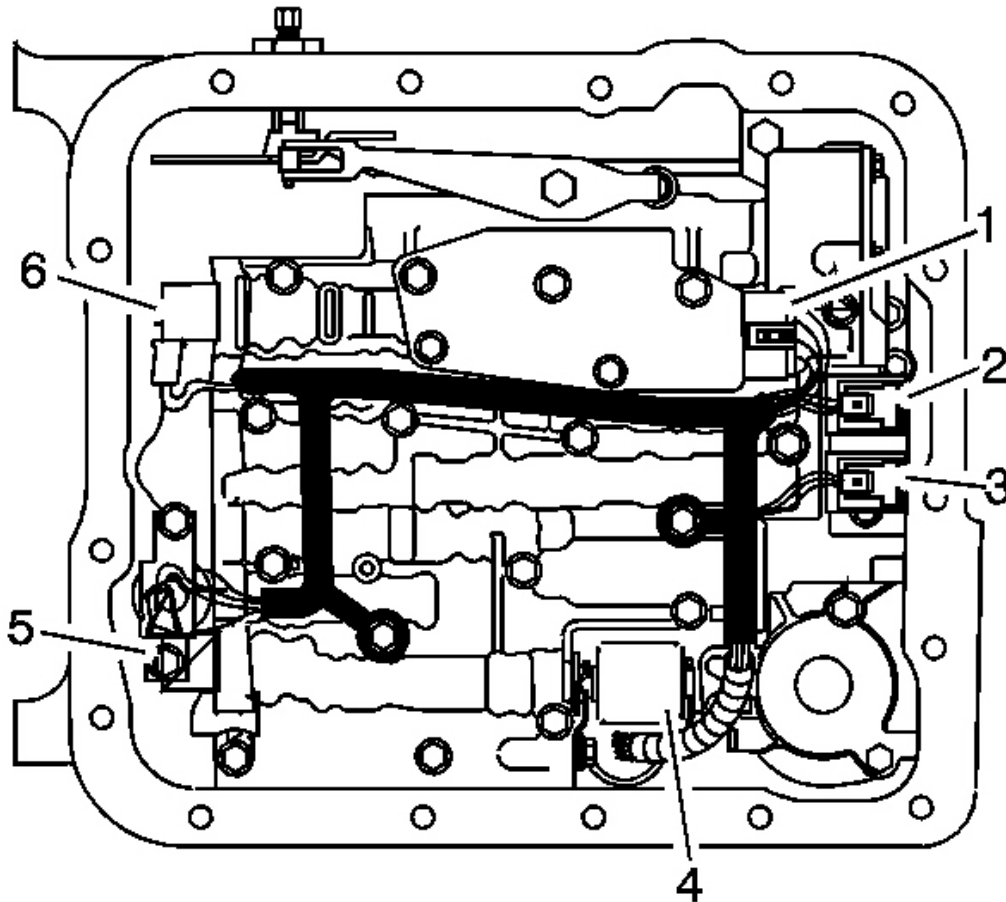

Fig. 128: Identifying Electrical Components In Valve Body
Courtesy of GENERAL MOTORS CORP.

16. Snap the wiring harness in place on the valve body bolts. Ensure the harness loom tab is located under the TFP switch.
17. Connect the internal wiring harness electrical connectors to the following components:
 - The TFP manual valve position switch (1)
 - The 1-2 shift solenoid (2)
 - The 2-3 shift solenoid (3)
 - The pressure control solenoid (4)
 - The TCC/PWM solenoid (5)

- The 3-2 shift solenoid (6)
18. Install the transmission filter and oil pan. Refer to **Automatic Transmission Fluid and Filter Replacement**.

IMPORTANT: It is recommended that transmission adaptive pressure (TAP) information be reset.

Resetting the TAP values using a scan tool will erase all learned values in all cells. As a result, The ECM, PCM or TCM will need to relearn TAP values. Transmission performance may be affected as new TAP values are learned.

19. Reset the TAP values. Refer to **Transmission Adaptive Functions**.

CONTROL AND SHIFT SOLENOIDS REPLACEMENT

Removal Procedure

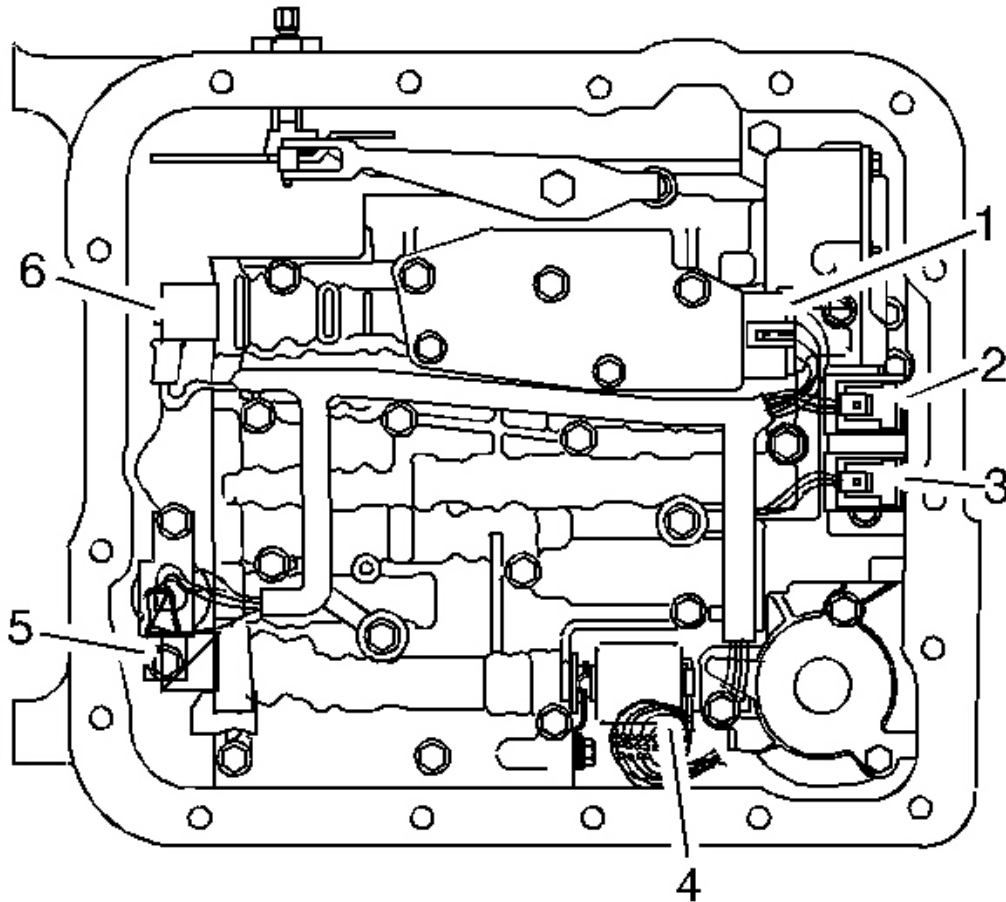

Fig. 129: Identifying Valve Body Electrical Connections
Courtesy of GENERAL MOTORS CORP.

1. Remove the transmission oil pan and filter. Refer to **Automatic Transmission Fluid and Filter Replacement**.

IMPORTANT: Do not remove the valve body for the following procedures. Removal of the 1-2 accumulator is necessary only if servicing the pressure control solenoid.

2. Remove the 1-2 accumulator if necessary. Refer to **Accumulator Assembly, Spacer Plate and Gaskets**.

3. Disconnect the internal wiring harness electrical connectors from the following components:

- Transmission fluid pressure switch (1)
- 1-2 shift control solenoid (2)
- 2-3 shift control solenoid (3)
- Pressure control solenoid (4)
- TCC PWM solenoid (5)
- 3-2 control solenoid (6)

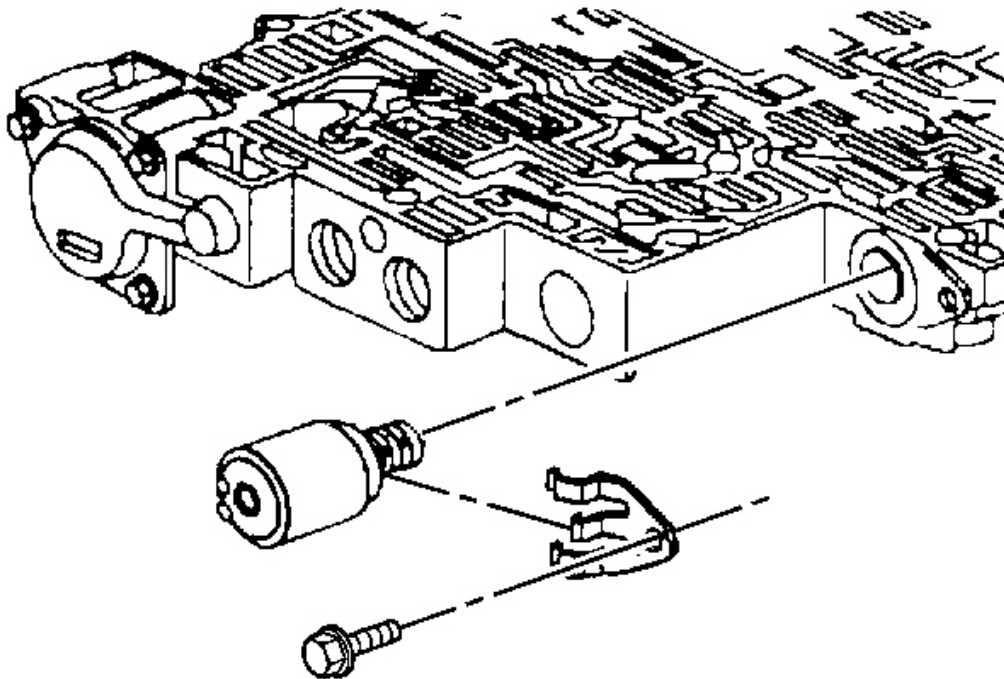

Fig. 130: Locating Pressure Control Solenoid & Retainer
Courtesy of GENERAL MOTORS CORP.

4. Remove the pressure control solenoid retainer.
5. Remove the pressure control solenoid.

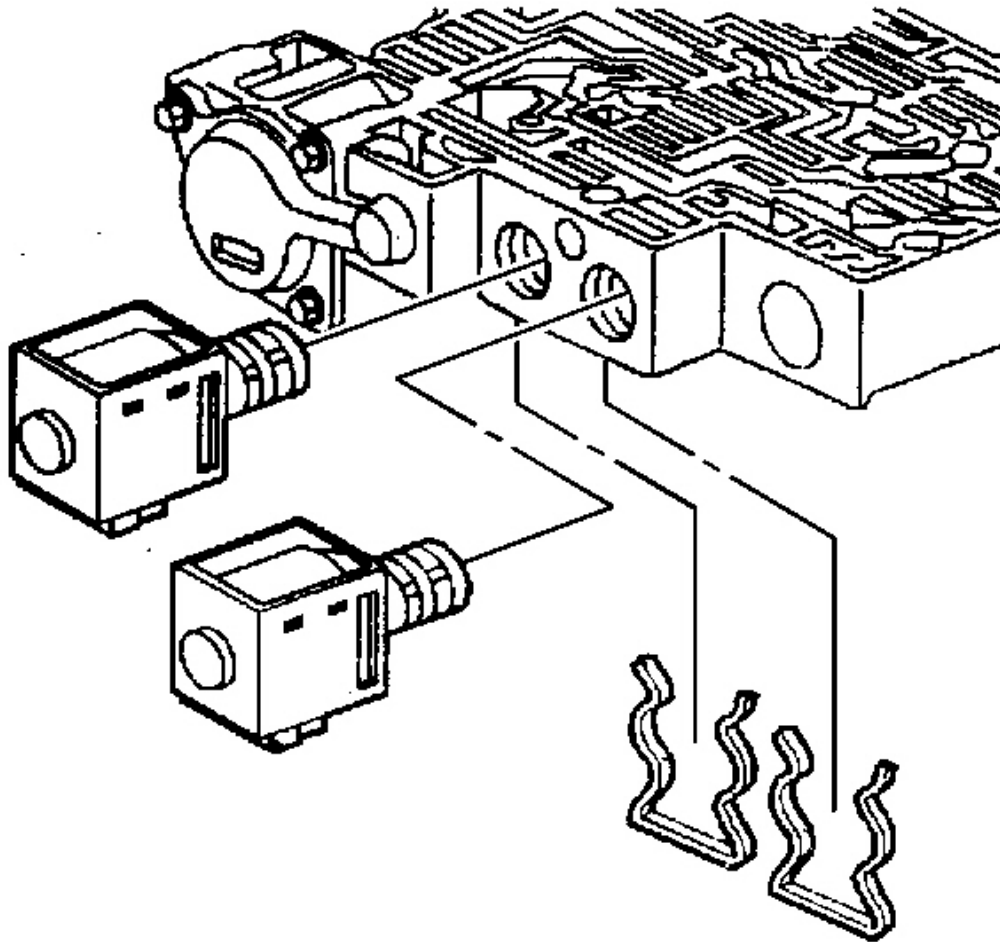

Fig. 131: View Of 1-2 & 2-3 Shift Solenoids & Retainers
Courtesy of GENERAL MOTORS CORP.

6. Remove the 1-2 and 2-3 shift solenoid retainers with a small screwdriver. Rotate the solenoids in the bores, if necessary, until the flat part of the retainers are visible.
7. Remove the 1-2 and 2-3 shift solenoids.

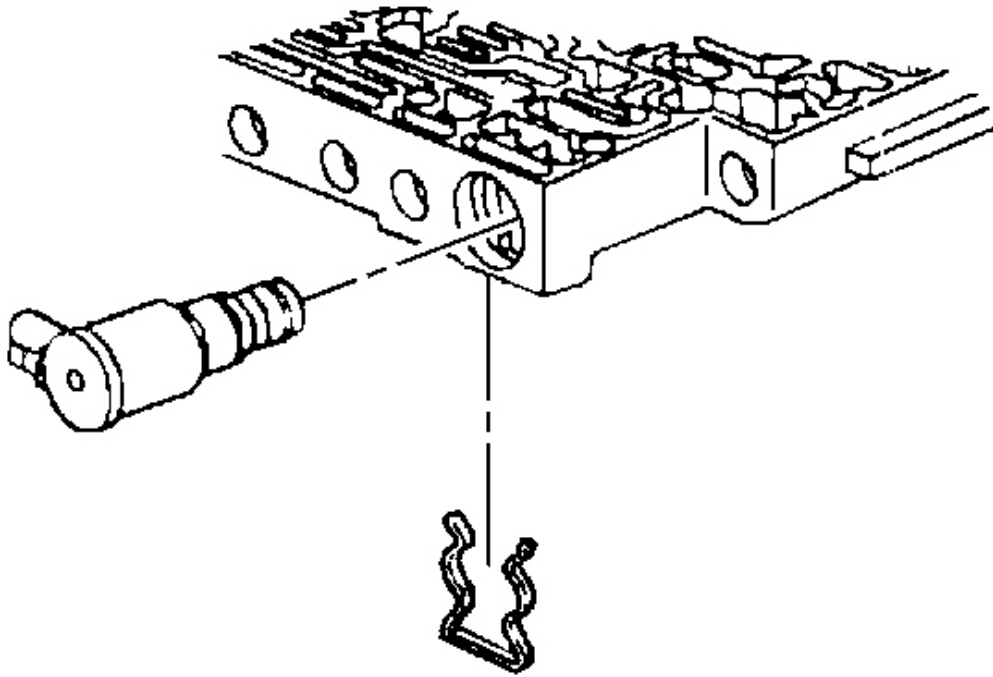

Fig. 132: View Of 3-2 Control Solenoid & Retainer
Courtesy of GENERAL MOTORS CORP.

8. Remove the 3-2 control solenoid retainer with a small screwdriver. Rotate the solenoid in the bore, if necessary, until the flat part of the retainer is visible.
9. Remove the 3-2 control solenoid.

Installation Procedure

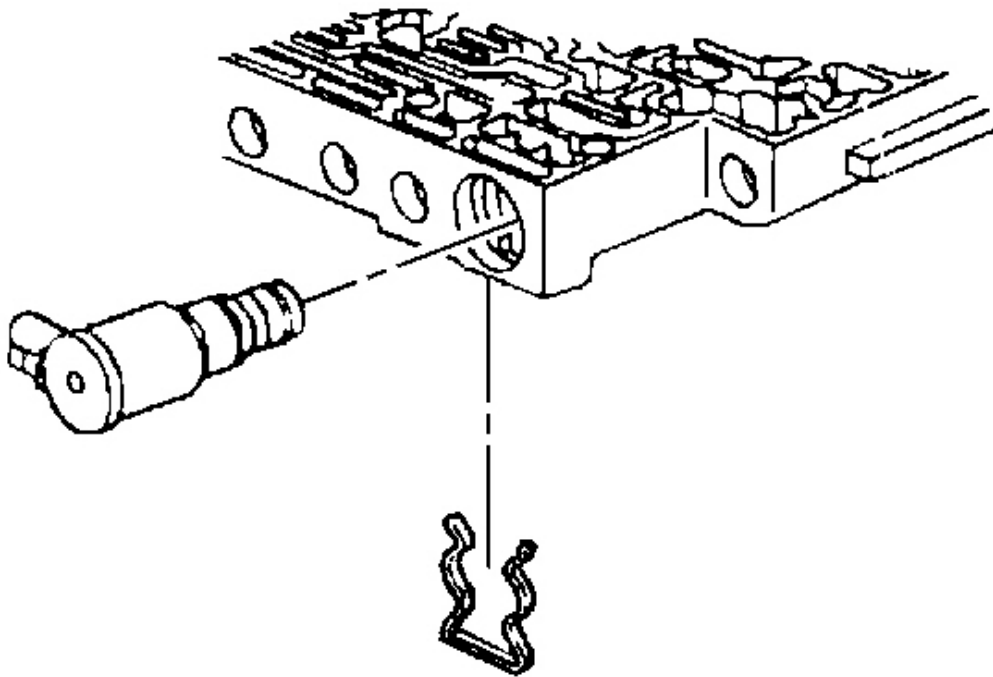

Fig. 133: View Of 3-2 Control Solenoid & Retainer
Courtesy of GENERAL MOTORS CORP.

1. Install the 3-2 control solenoid.
2. Install the 3-2 control solenoid retainer.

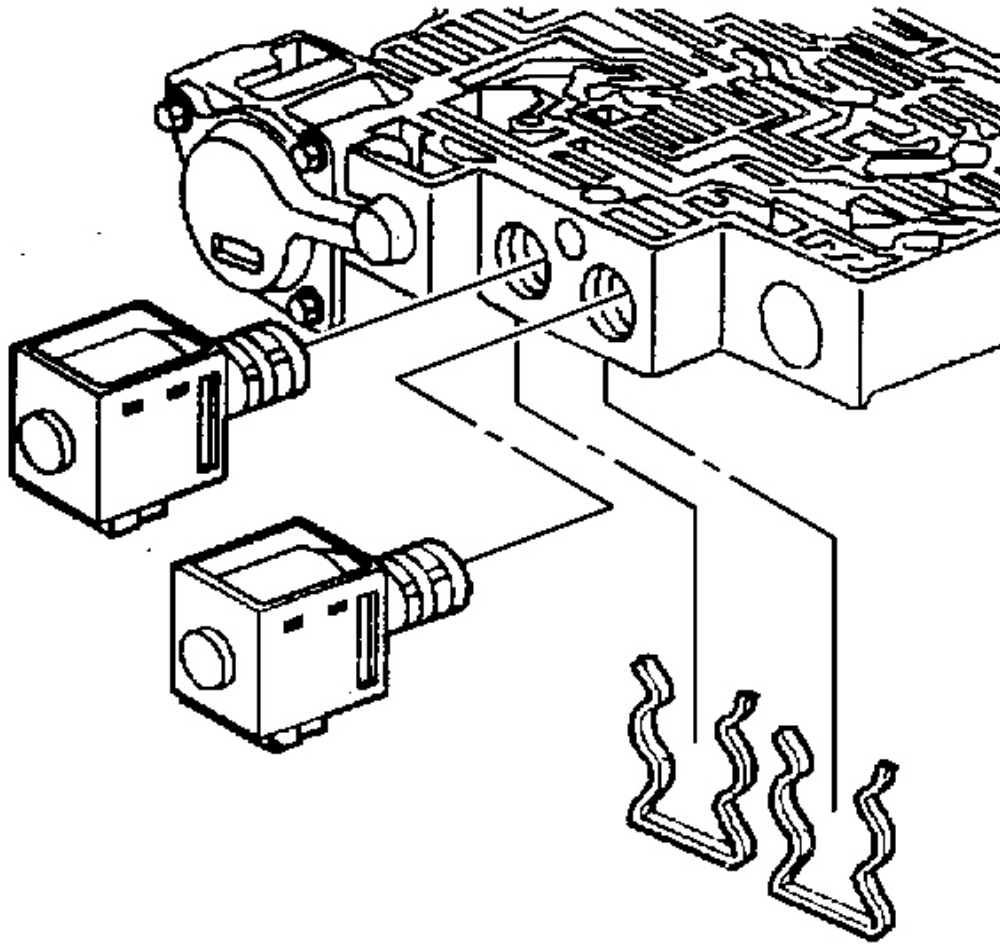

Fig. 134: View Of 1-2 & 2-3 Shift Solenoids & Retainers
Courtesy of GENERAL MOTORS CORP.

3. Install the 1-2 and 2-3 shift solenoids.
4. Install the 1-2 and 2-3 shift solenoid retainers.

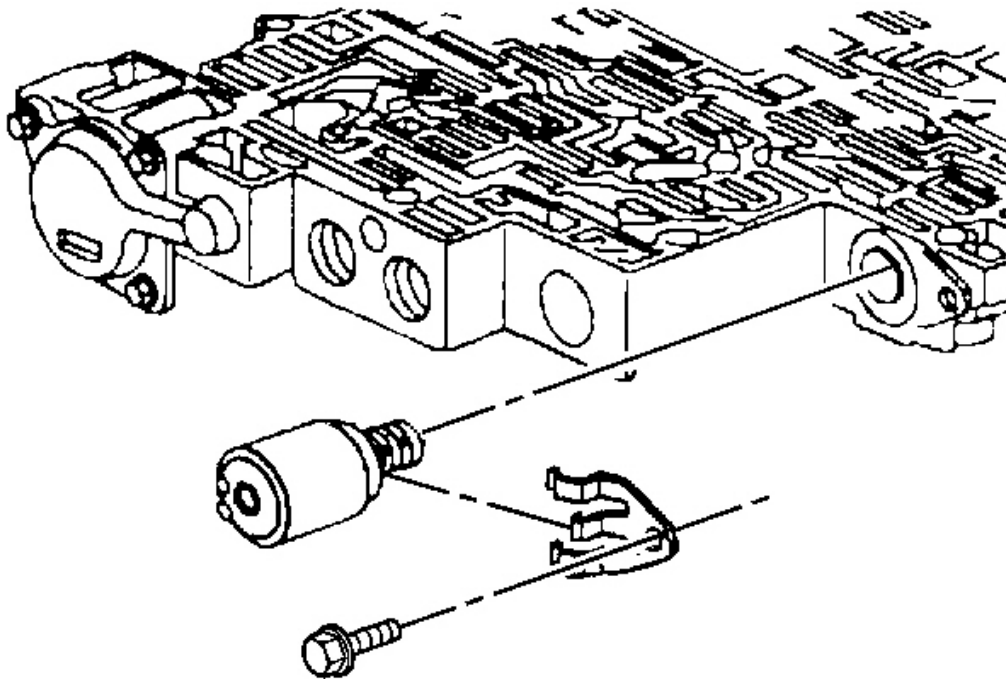

Fig. 135: Locating Pressure Control Solenoid & Retainer
Courtesy of GENERAL MOTORS CORP.

NOTE: Refer to Fastener Notice .

5. Install the pressure control solenoid.

Ensure that the electrical connection is facing downward.

6. Install the pressure control solenoid retainer and retaining bolt.

Tighten: Tighten the pressure control solenoid retaining bolt to 11 N.m (97 lb in).

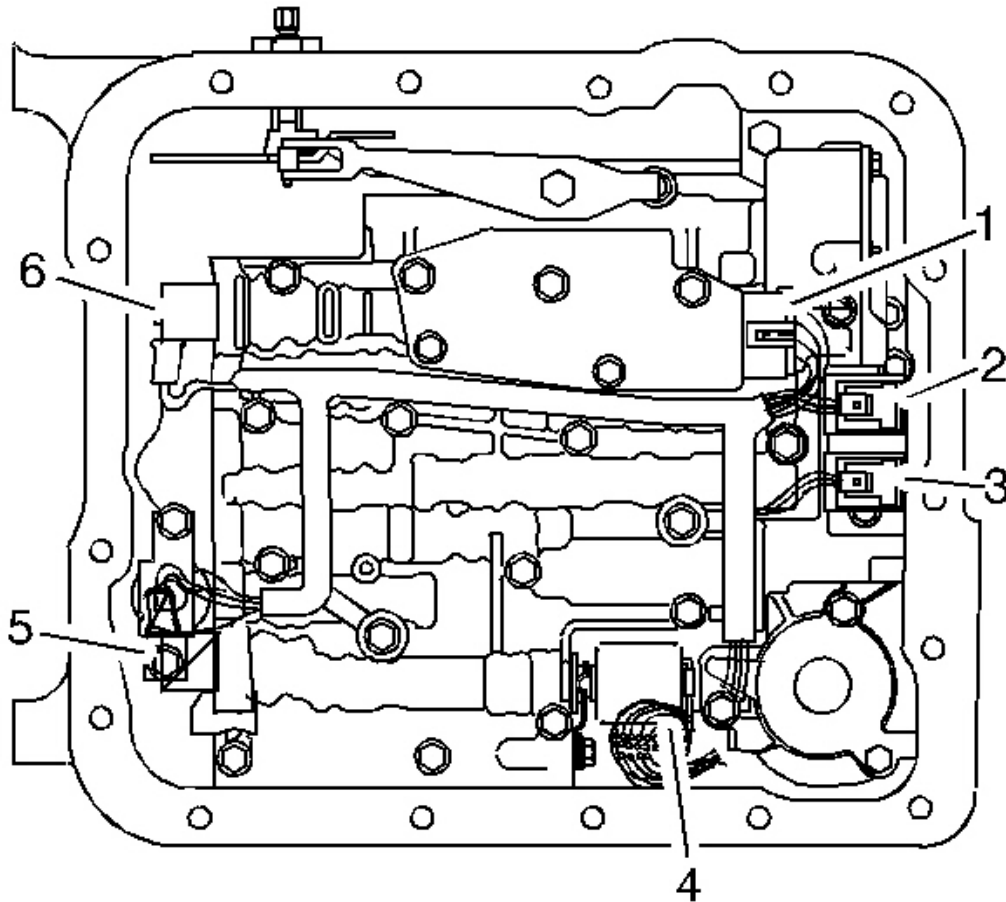

Fig. 136: Identifying Valve Body Electrical Connections
Courtesy of GENERAL MOTORS CORP.

7. Connect the internal wiring harness electrical connectors to the following components:
 - Transmission fluid pressure switch (1)
 - 1-2 shift control solenoid (2)
 - 2-3 shift control solenoid (3)
 - Pressure control solenoid (4)
 - TCC PWM solenoid (5)
 - 3-2 control solenoid (6)
8. Install the 1-2 accumulator. Refer to **Accumulator Assembly, Spacer Plate and Gaskets.**

9. Install the transmission filter and oil pan. Refer to **Automatic Transmission Fluid and Filter Replacement**.

IMPORTANT: It is recommended that transmission adaptive pressure (TAP) information be reset.

Resetting the TAP values using a scan tool will erase all learned values in all cells. As a result, The ECM, PCM or TCM will need to relearn TAP values. Transmission performance may be affected as new TAP values are learned.

10. Reset the TAP values. Refer to **Transmission Adaptive Functions**.

TORQUE CONVERTER CLUTCH PULSE WIDTH MODULATION SOLENOID, TORQUE CONVERTER CLUTCH SOLENOID AND WIRING HARNESS

Tools Required

J 28458 Seal Protector Retainer Installer. See **Special Tools**.

Removal Procedure

1. Remove the transmission oil pan and the filter. Refer to **Automatic Transmission Fluid and Filter Replacement**.

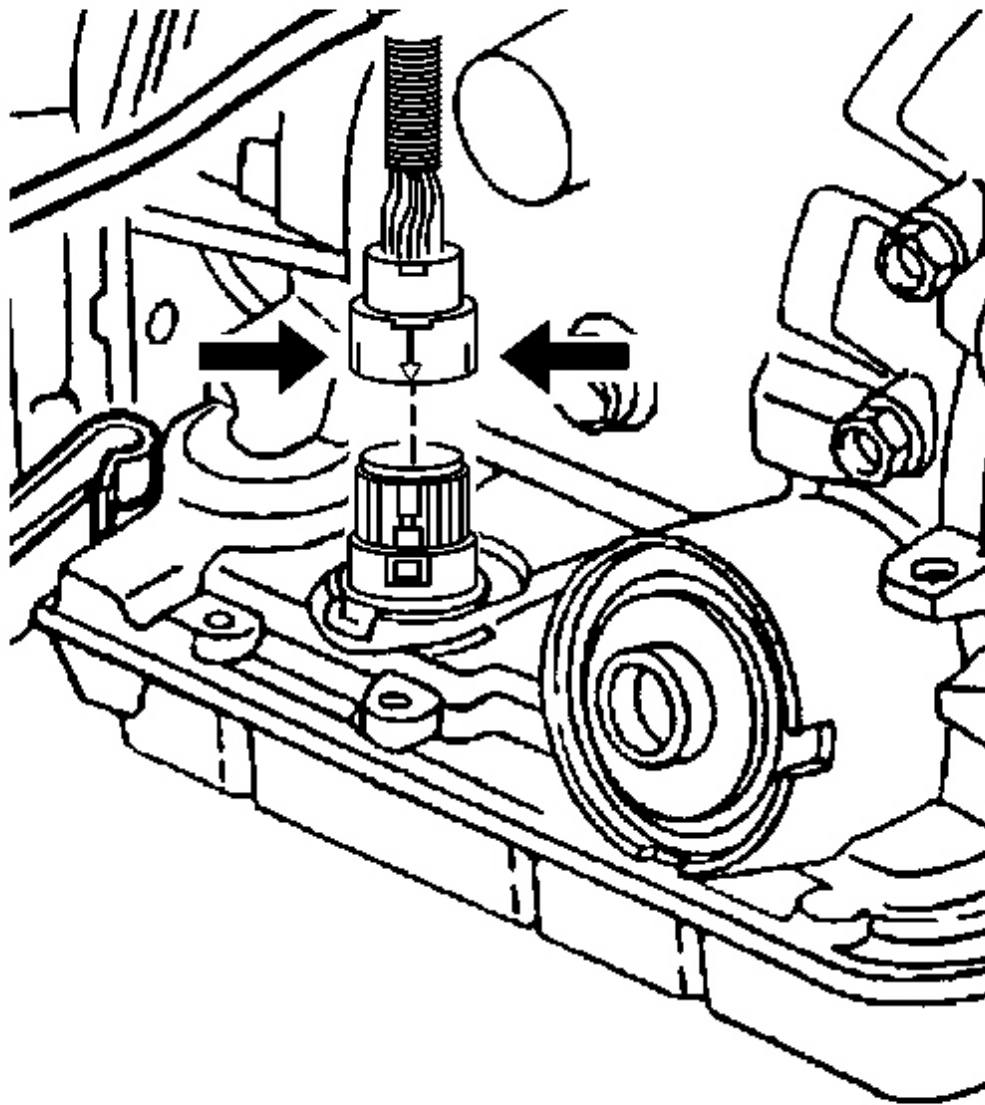

Fig. 137: View Of Transmission Harness 20-Way Connector
Courtesy of GENERAL MOTORS CORP.

2. Disconnect the transmission harness 20-way connector from the transmission internal harness pass-through connector.

Depress both tabs on the connector and pull straight up; do not pry the connector.

IMPORTANT: Removal of the valve body is not necessary for the following procedure.

3. Remove the 1-2 accumulator assembly. Do not remove the spacer plate. Refer to Accumulator Assembly, Spacer Plate and Gaskets.

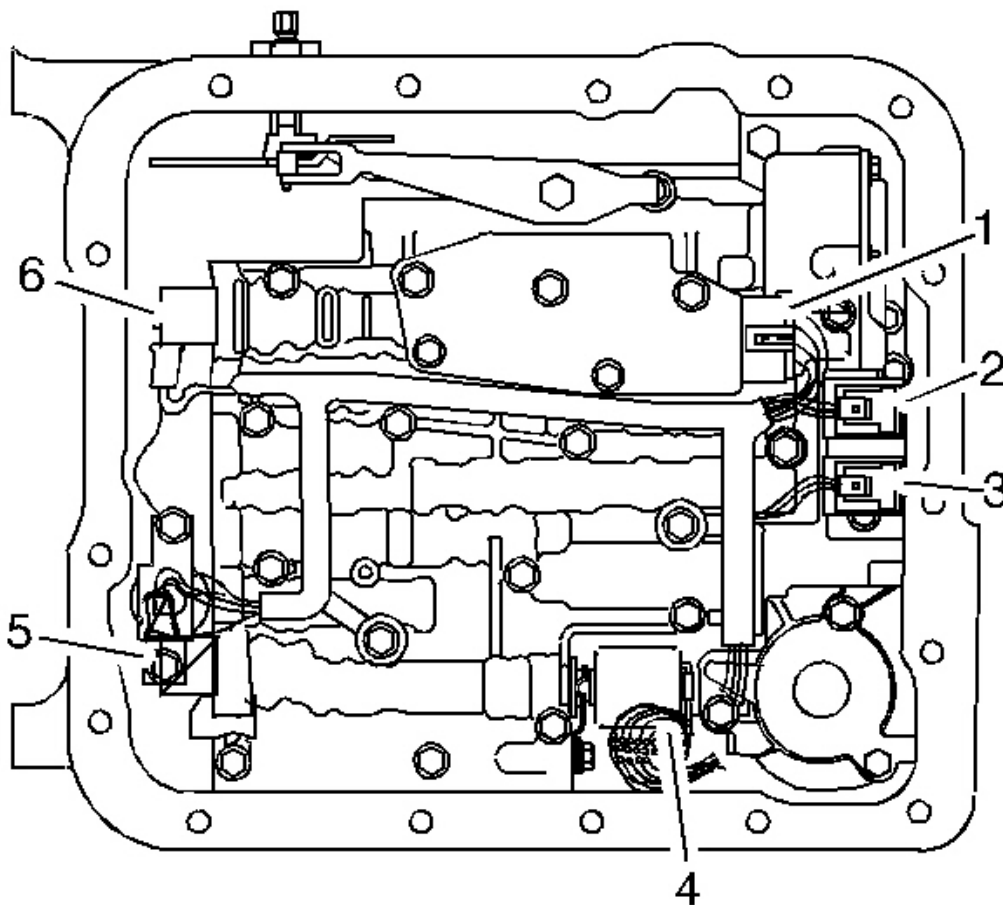

Fig. 138: Identifying Valve Body Electrical Connections
Courtesy of GENERAL MOTORS CORP.

4. Disconnect the internal wiring harness electrical connectors from the following components:
 - Transmission fluid pressure switch (1)
 - 1-2 shift control solenoid (2)

- 2-3 shift control solenoid (3)
- Pressure control solenoid (4)
- TCC PWM solenoid (5)
- 3-2 control solenoid (6)

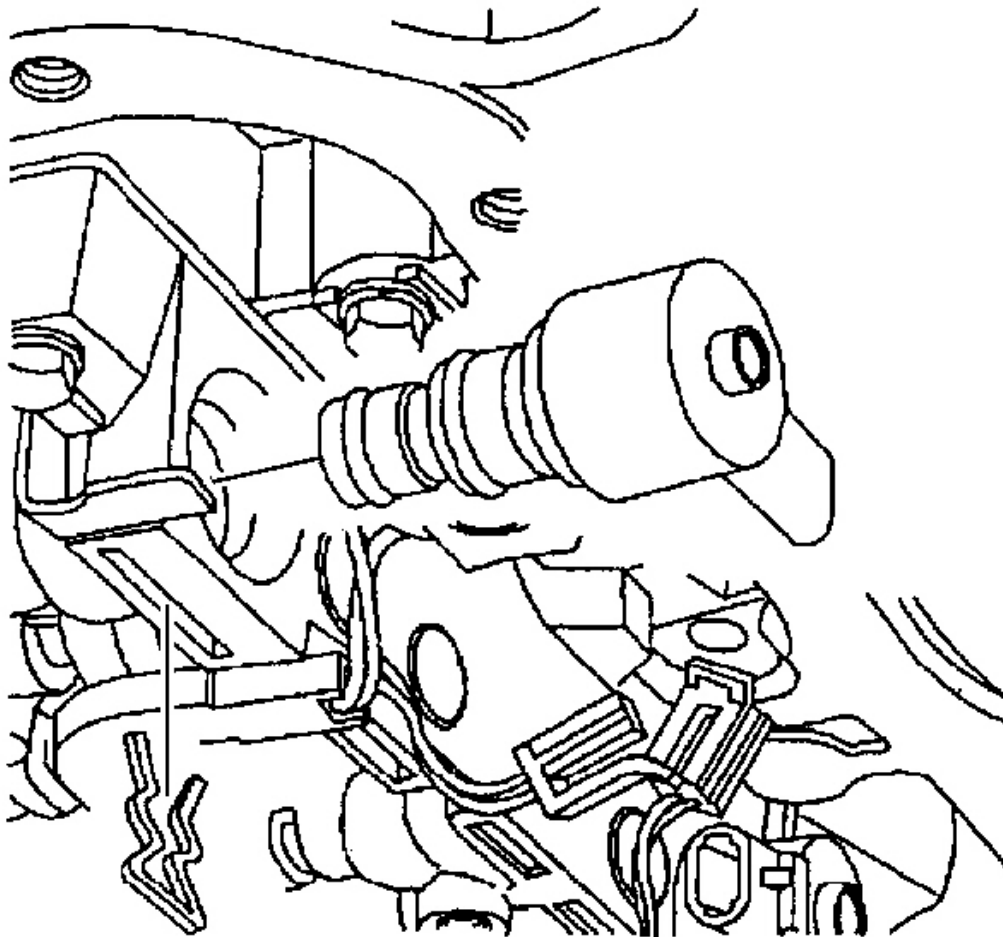

Fig. 139: View Of TCC PWM Solenoid & Retainer
Courtesy of GENERAL MOTORS CORP.

5. Remove the TCC PWM solenoid retainer with a small screwdriver. Rotate the solenoid in the bore, if necessary, until the flat part of the retainer is visible.
6. Remove the TCC PWM solenoid in order to access one of the TCC solenoid retaining bolts.

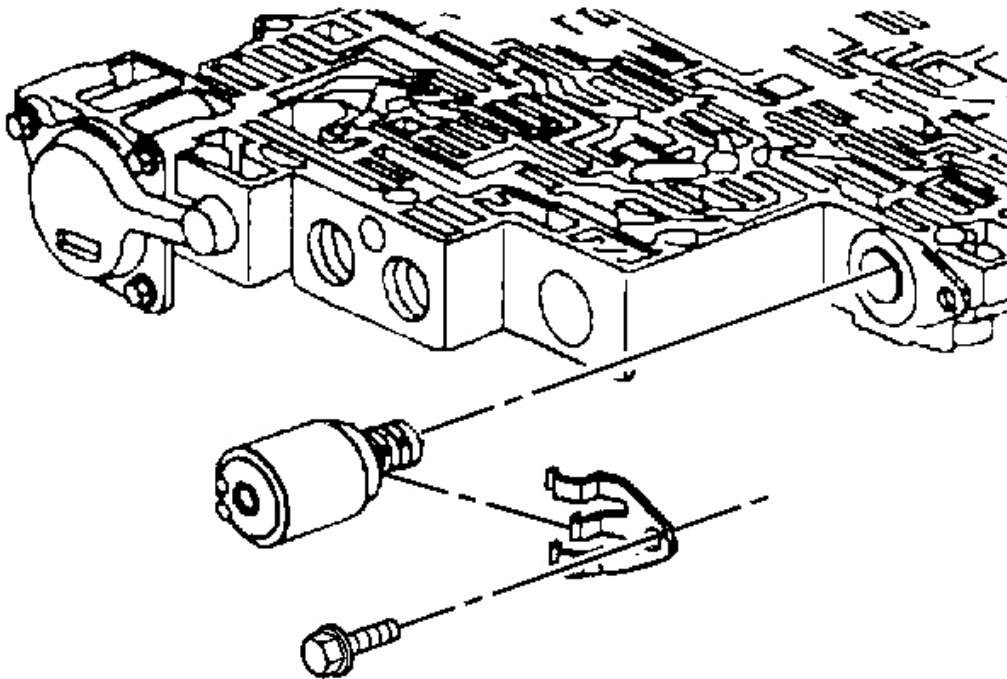

Fig. 140: Locating Pressure Control Solenoid & Retainer
Courtesy of GENERAL MOTORS CORP.

7. Remove the pressure control solenoid retainer.
8. Remove the pressure control solenoid.

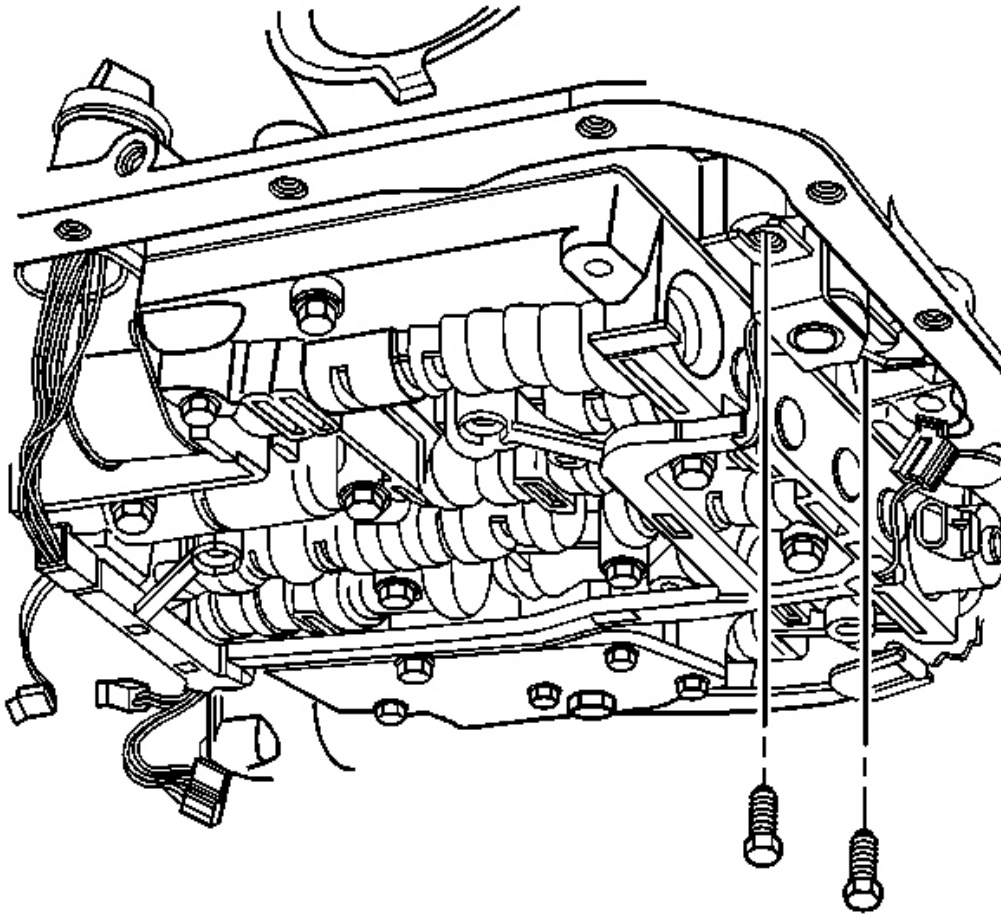

Fig. 141: View Of TCC Solenoid Retaining Bolts
Courtesy of GENERAL MOTORS CORP.

9. Remove the TCC solenoid retaining bolts.

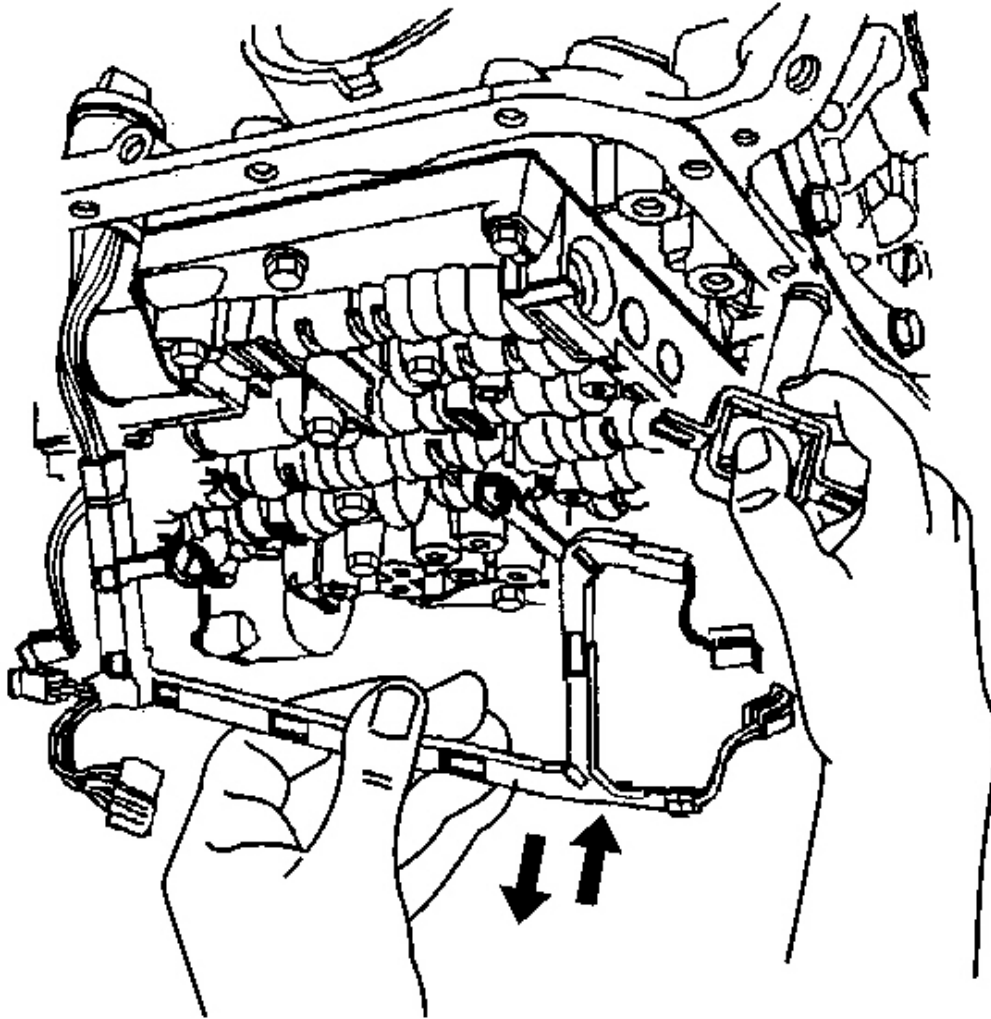

Fig. 142: View Of TCC Solenoid & Wiring Harness
Courtesy of GENERAL MOTORS CORP.

10. Using the **J 28458** , release the pass-through electrical connector from the transmission case. See **Special Tools**.
 1. Use the small end of the **J 28458** over the top of the connector. See **Special Tools**.
 2. Twist in order to release the four tabs retaining the connector.
 3. Pull the harness connector down through the transmission case.

11. Remove the TCC solenoid with O-ring seal and wiring harness assembly from the transmission case.

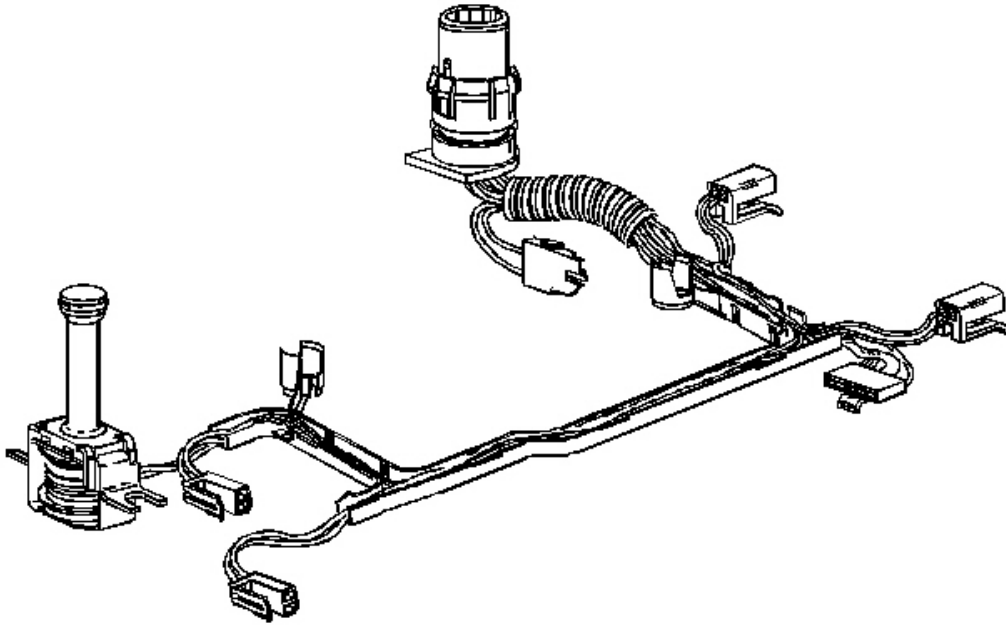

Fig. 143: View Of TCC Solenoid & Wiring Harness
Courtesy of GENERAL MOTORS CORP.

12. Inspect the TCC solenoid and wiring harness assembly for the following defects:
 - Damage
 - Cracked connectors
 - Exposed wires
 - Loose pins

Installation Procedure

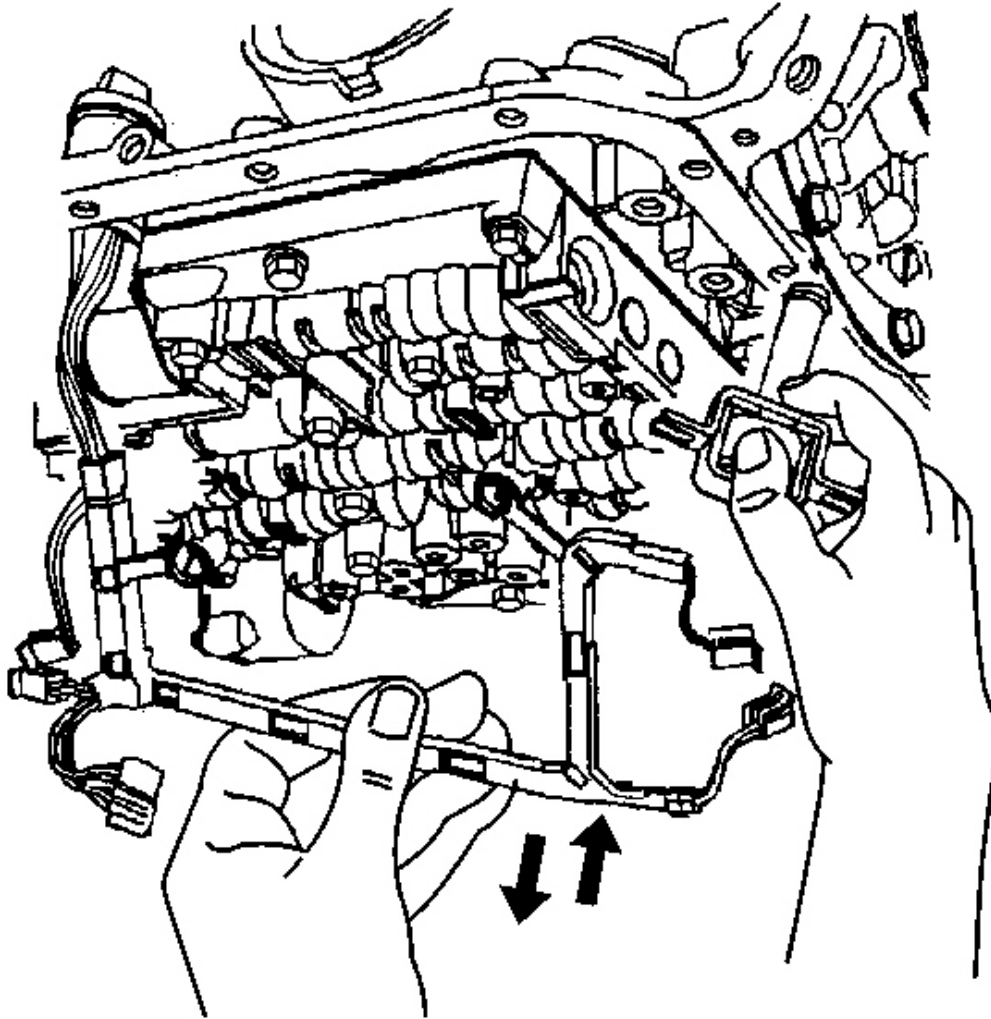

Fig. 144: View Of TCC Solenoid & Wiring Harness
Courtesy of GENERAL MOTORS CORP.

1. Install the wiring harness and TCC solenoid assembly with a new O-ring seal to the transmission.
2. Install the pass-through electrical connector to the transmission case.

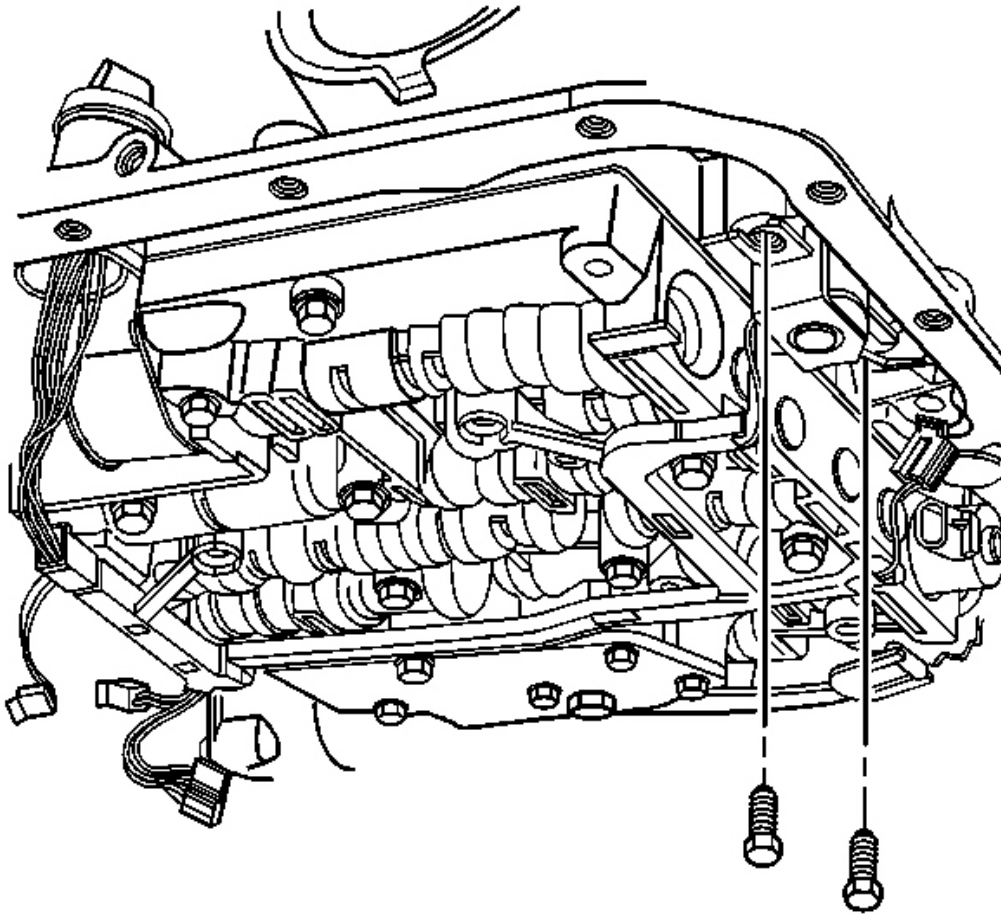

Fig. 145: View Of TCC Solenoid Retaining Bolts
Courtesy of GENERAL MOTORS CORP.

NOTE: Refer to Fastener Notice .

3. Install the TCC solenoid retaining bolts.

Tighten: Tighten the TCC solenoid retaining bolts to 11 N.m (97 lb in).

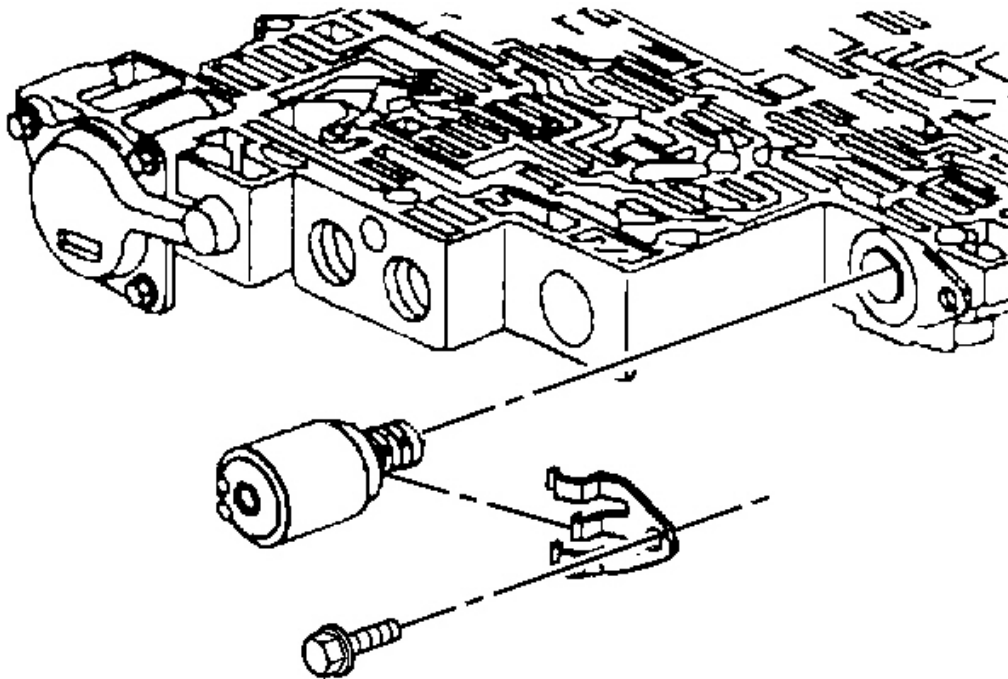

Fig. 146: Locating Pressure Control Solenoid & Retainer
Courtesy of GENERAL MOTORS CORP.

4. Install the pressure control solenoid.

Ensure that the electrical connection is facing downward.

5. Install the pressure control solenoid retainer and retaining bolt.

Tighten: Tighten the pressure control solenoid retaining bolt to 11 N.m (97 lb in).

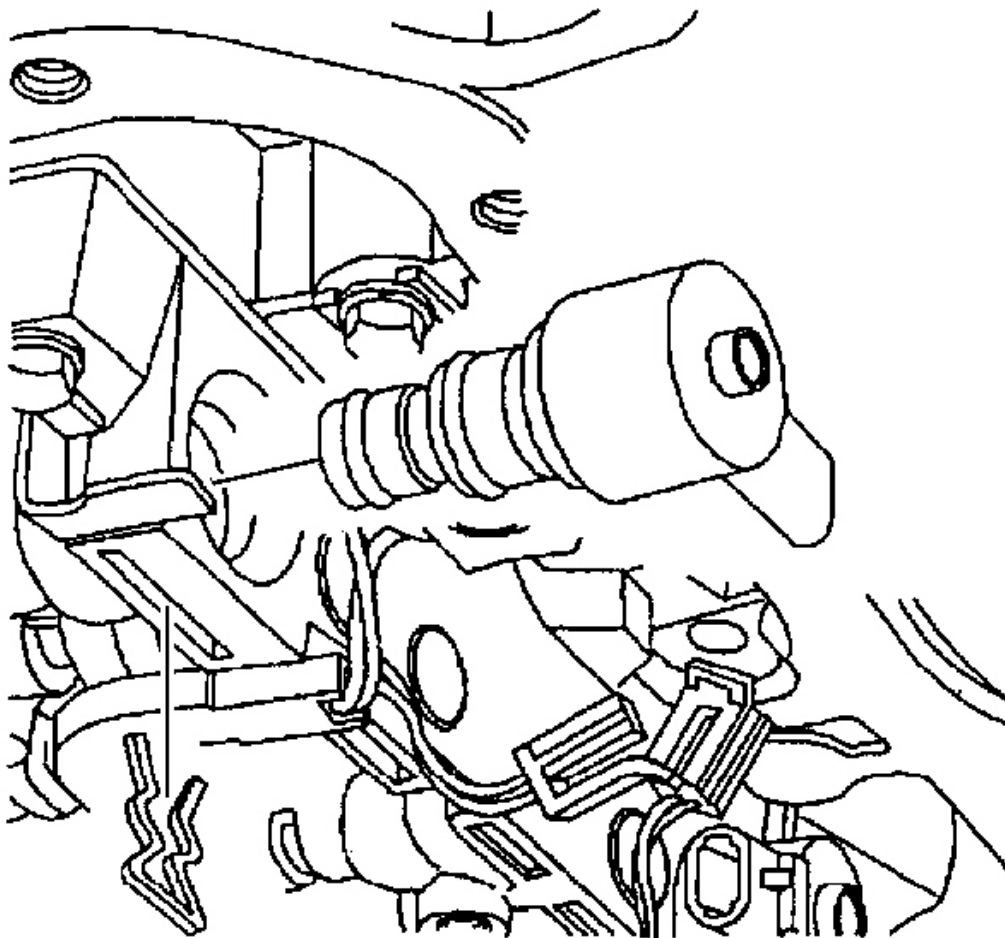

Fig. 147: View Of TCC PWM Solenoid & Retainer
Courtesy of GENERAL MOTORS CORP.

6. Install the TCC PWM solenoid to the control valve body.
7. Install the TCC PWM solenoid retainer.

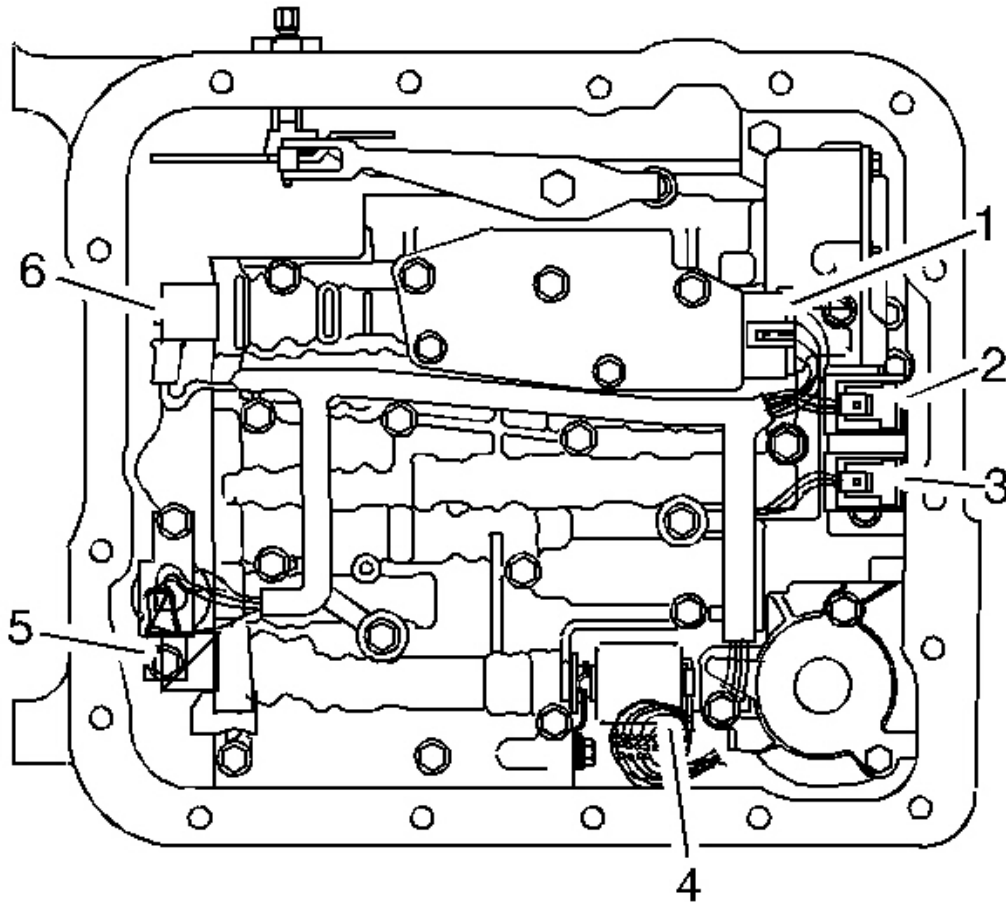

Fig. 148: Identifying Valve Body Electrical Connections
Courtesy of GENERAL MOTORS CORP.

8. Connect the internal wiring harness electrical connectors to the following components:
 - Transmission fluid pressure switch (1)
 - 1-2 shift control solenoid (2)
 - 2-3 shift control solenoid (3)
 - Pressure control solenoid (4)
 - TCC PWM solenoid (5)
 - 3-2 control solenoid (6)
9. Install the 1-2 accumulator. Refer to **Accumulator Assembly, Spacer Plate and Gaskets.**

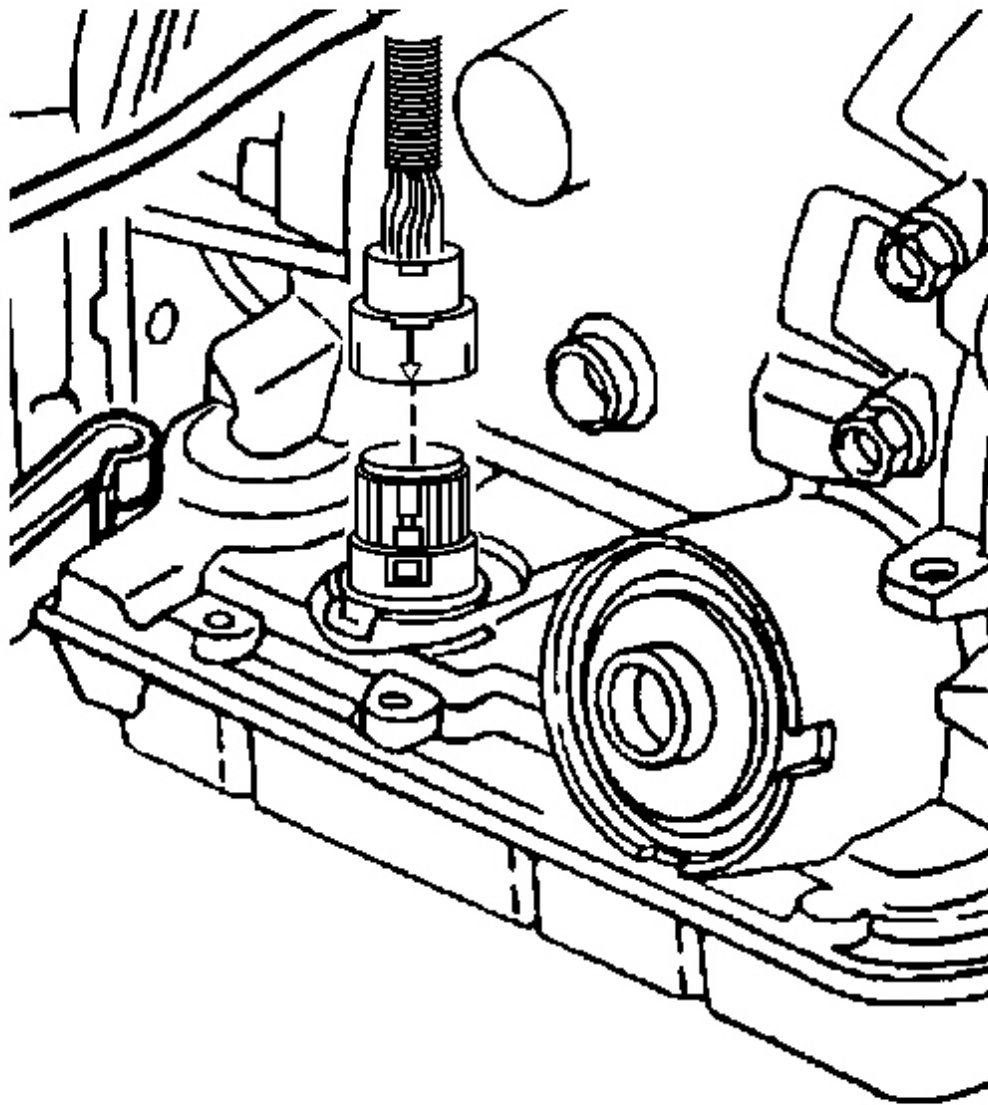

Fig. 149: View Of Transmission Harness 20-Way Connector
Courtesy of GENERAL MOTORS CORP.

10. Connect the transmission harness 20-way connector to the transmission pass-through connector.

Align the arrows on each half of the connector and insert straight down.

11. Install the transmission filter and oil pan. Refer to Automatic Transmission Fluid and Filter Replacement.

IMPORTANT: It is recommended that transmission adaptive pressure (TAP) information be reset.

Resetting the TAP values using a scan tool will erase all learned values in all cells. As a result, The ECM, PCM or TCM will need to relearn TAP values. Transmission performance may be affected as new TAP values are learned.

12. Reset the TAP values. Refer to Transmission Adaptive Functions.

ACCUMULATOR ASSEMBLY, SPACER PLATE AND GASKETS

Tools Required

- **J 25025-B** Pump and Valve Body Alignment Pin Set. See Special Tools.
- **J 36850** Transjel Lubricant

Removal Procedure

1. Remove the transmission oil pan and filter. Refer to Automatic Transmission Fluid and Filter Replacement.

IMPORTANT: The 1-2 accumulator can be removed without removing the control valve assembly.

2. Remove the control valve body. Refer to Valve Body and Pressure Switch Replacement.

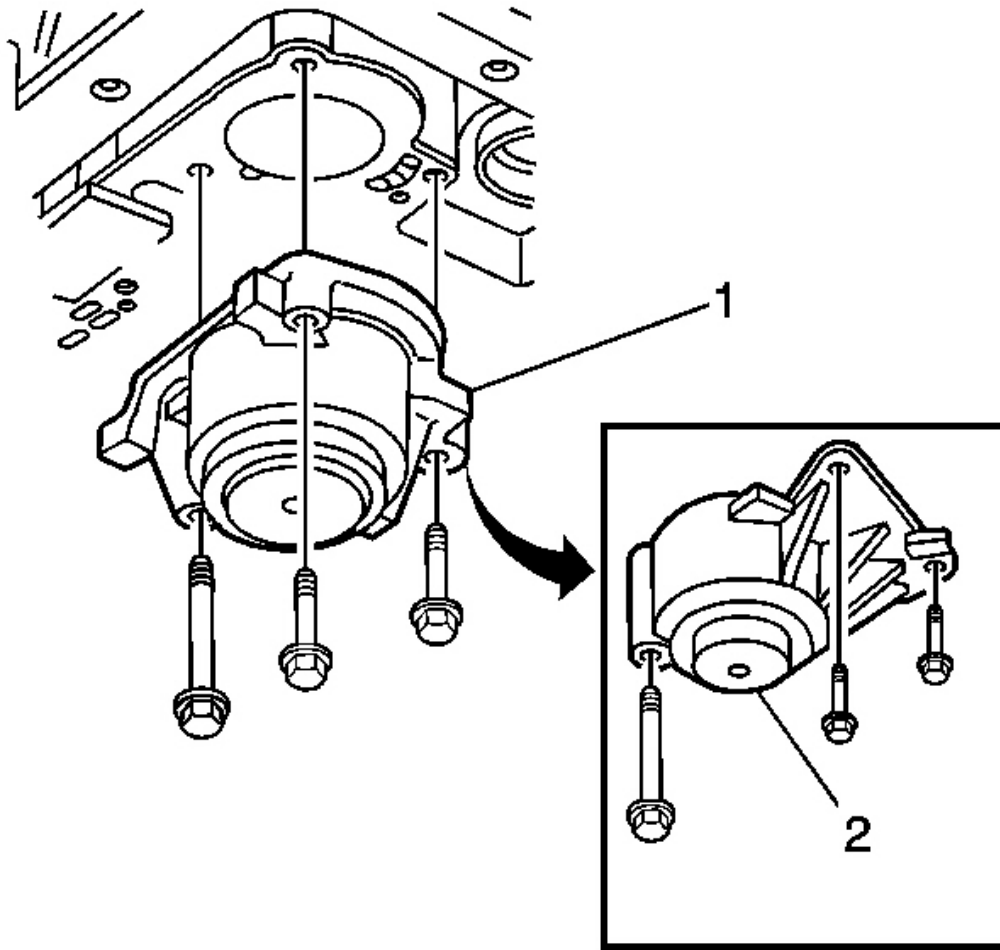

Fig. 150: View Of 1-2 Accumulator Cover Retaining Bolts
Courtesy of GENERAL MOTORS CORP.

3. Remove the accumulator cover retaining bolts.
4. Remove the 1-2 accumulator cover assembly.
 - RWD (1)
 - 4WD (2)

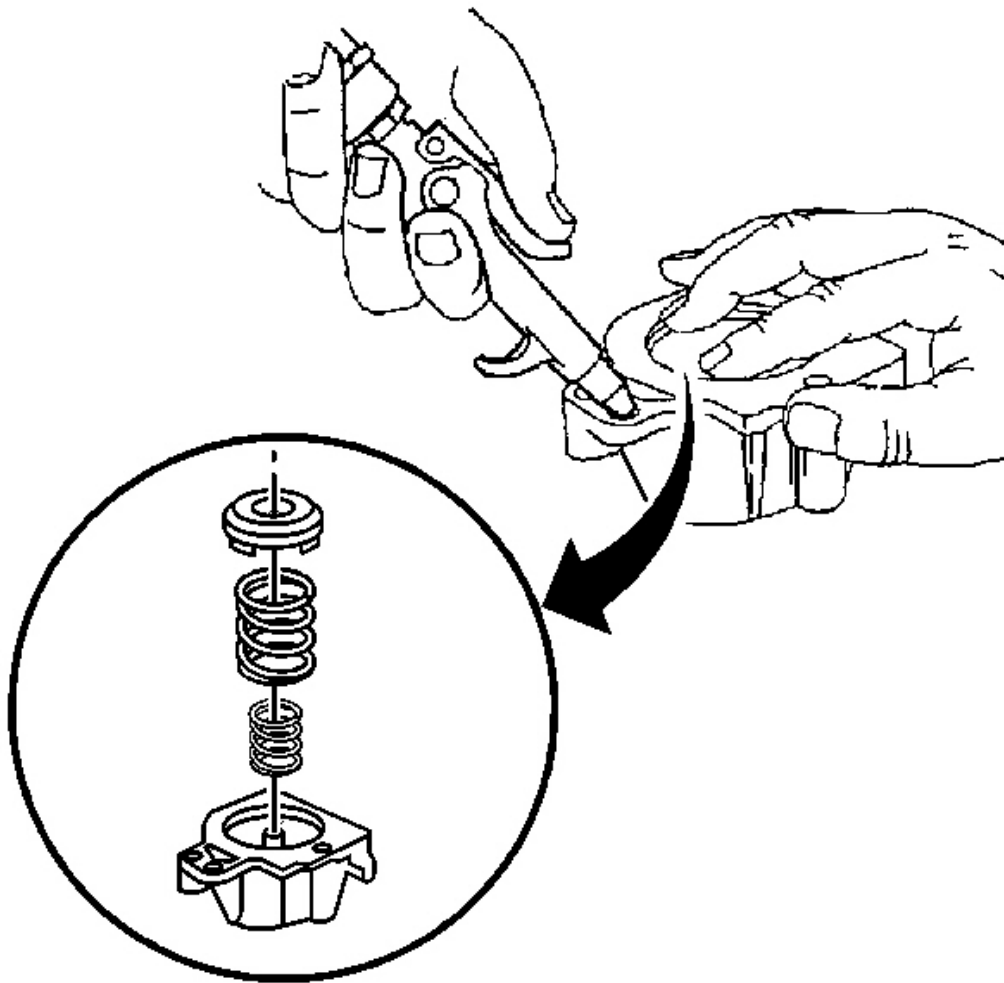

Fig. 151: Disassembling 1-2 Accumulator
Courtesy of GENERAL MOTORS CORP.

5. Disassemble the 1-2 accumulator.
 1. Blow compressed air into the 1-2 accumulator cover, as shown, to remove the 1-2 accumulator piston.
 2. Remove the 1-2 accumulator inner and outer springs.
6. Inspect the 1-2 accumulator inner and outer springs for cracks.

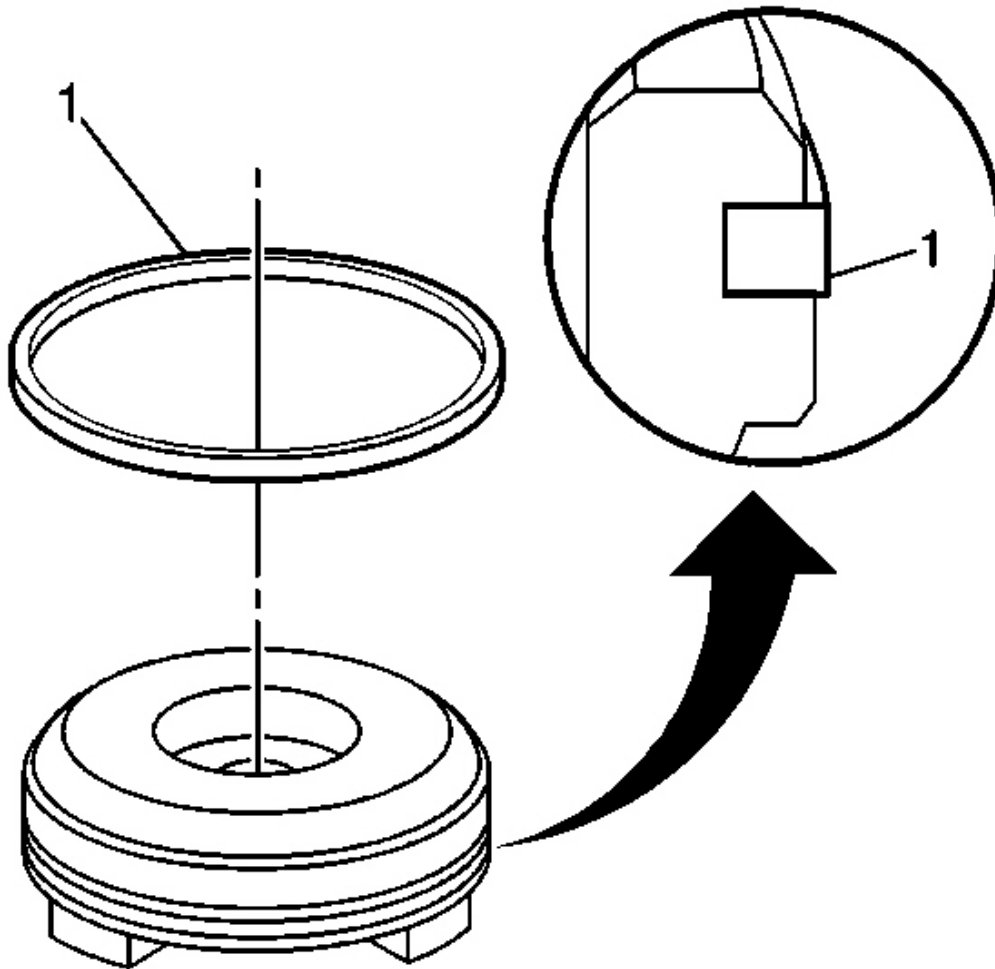

Fig. 152: View Of Accumulator Piston Seal & Accumulator Piston
Courtesy of GENERAL MOTORS CORP.

7. Remove the 1-2 accumulator piston seal (1) from the 1-2 accumulator piston.
8. Inspect the 1-2 accumulator piston for the following defects:
 - Porosity
 - Cracks
 - Scoring
 - Nicks and scratches

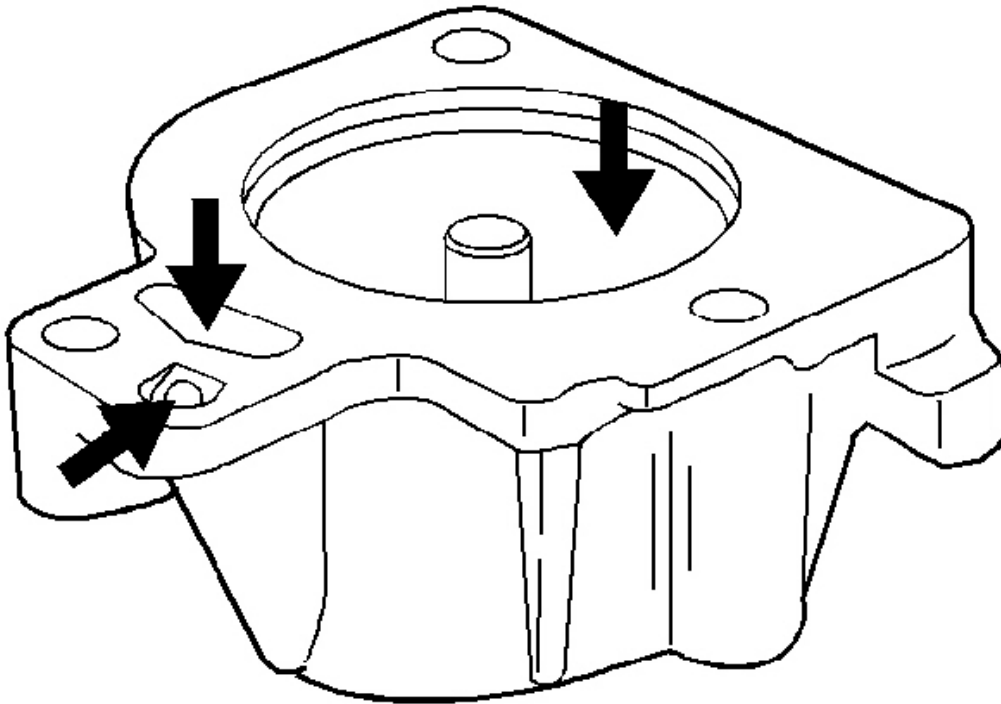

Fig. 153: Inspecting 1-2 Accumulator Cover
Courtesy of GENERAL MOTORS CORP.

9. Inspect the 1-2 accumulator cover for the following defects:
 - Porosity
 - Cracks
 - Scoring
 - Nicks and scratches

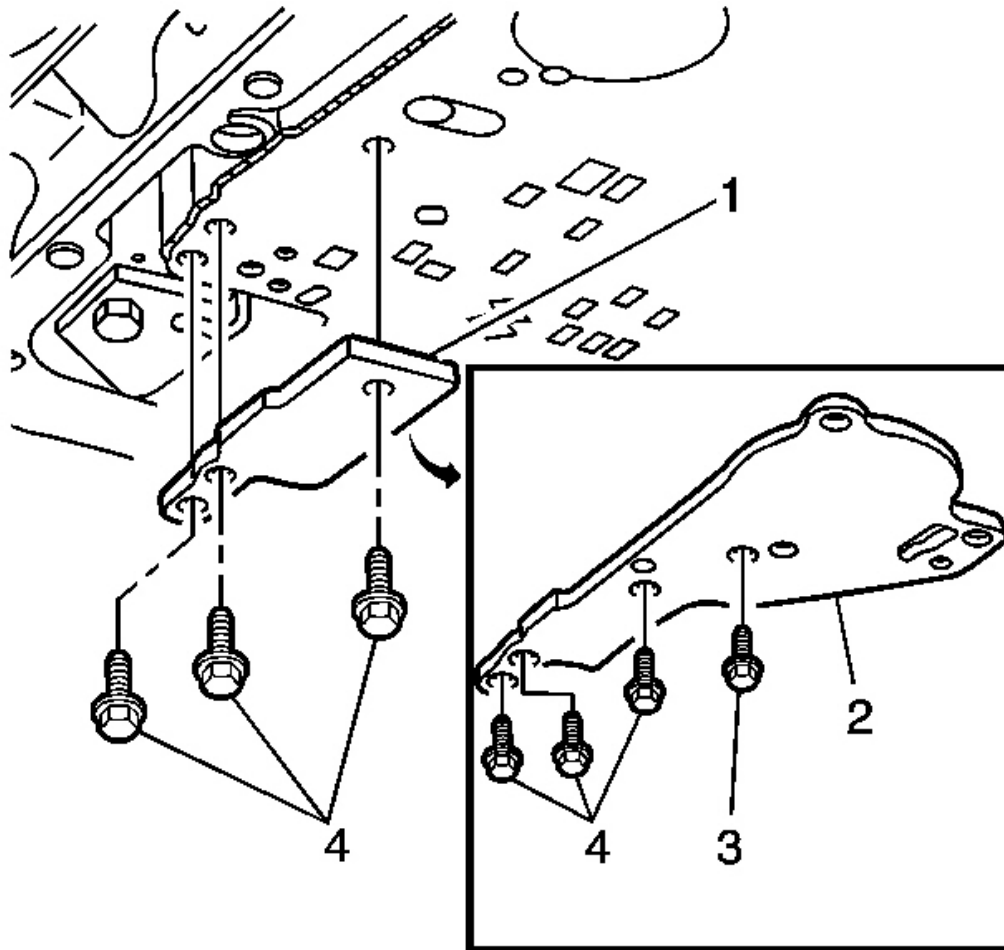

Fig. 154: View Of Spacer Plate Support Retaining Bolts
Courtesy of GENERAL MOTORS CORP.

10. Remove the spacer plate support retaining bolts.
 - RWD (4)
 - 4WD (3, 4)

IMPORTANT: Use care not to drop the following items that will be removed along with the spacer plate:

- The number 1 checkball

- **The 3-4 accumulator spring**

11. Remove the spacer plate support.

- RWD (1)
- 4WD (2)

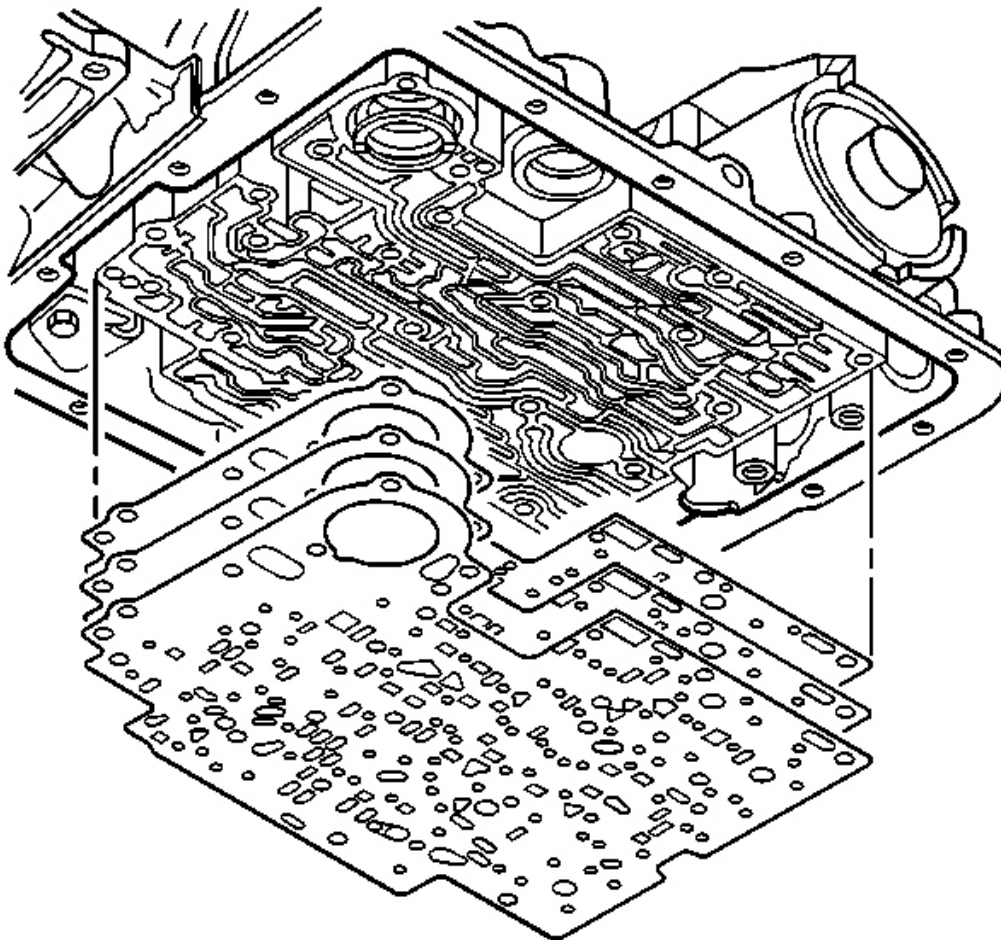

Fig. 155: View Of Spacer Plates And Spacer Plate Body Gasket
Courtesy of GENERAL MOTORS CORP.

12. Remove the following:

- The spacer plate to valve body gasket

- The spacer plate
- The spacer plate to transmission case gasket

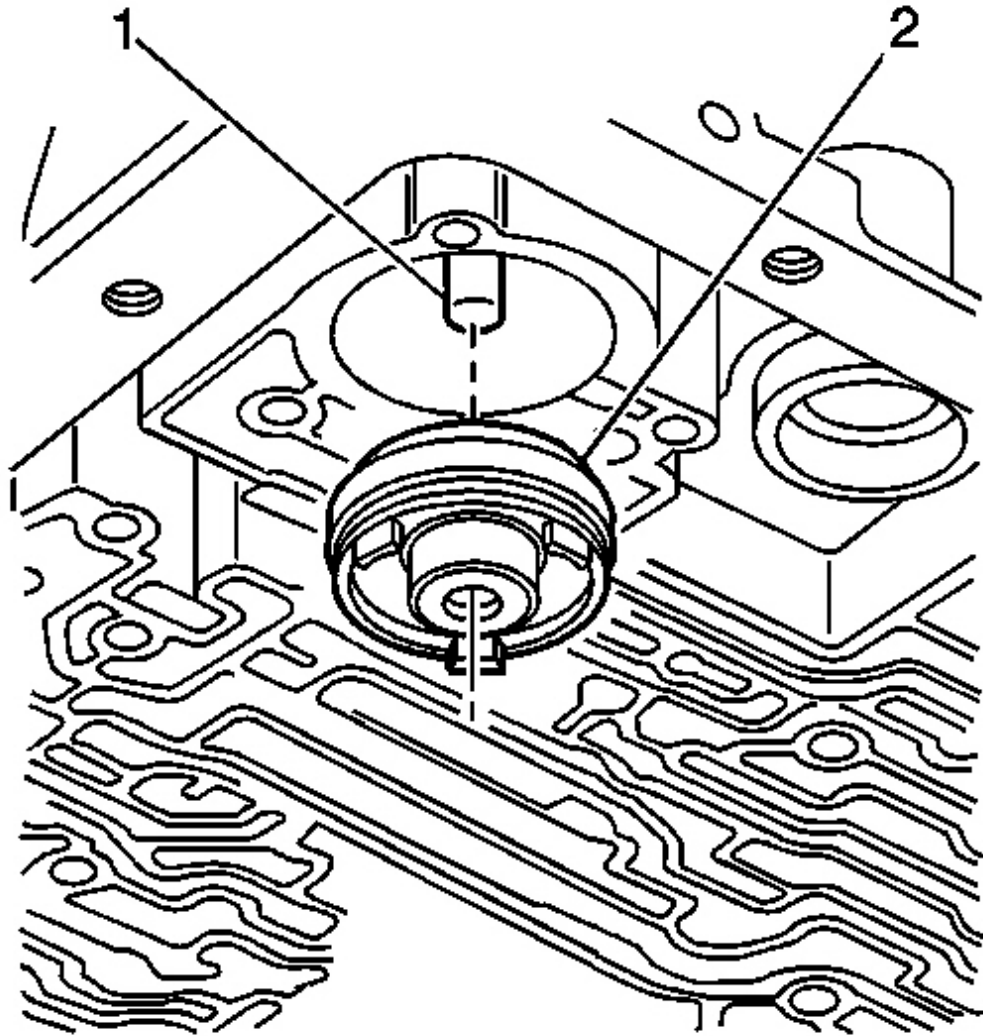

Fig. 156: Identifying 3-4 Accumulator Piston
Courtesy of GENERAL MOTORS CORP.

13. Remove the 3-4 accumulator piston (2).
14. Inspect the 3-4 accumulator spring for cracks.

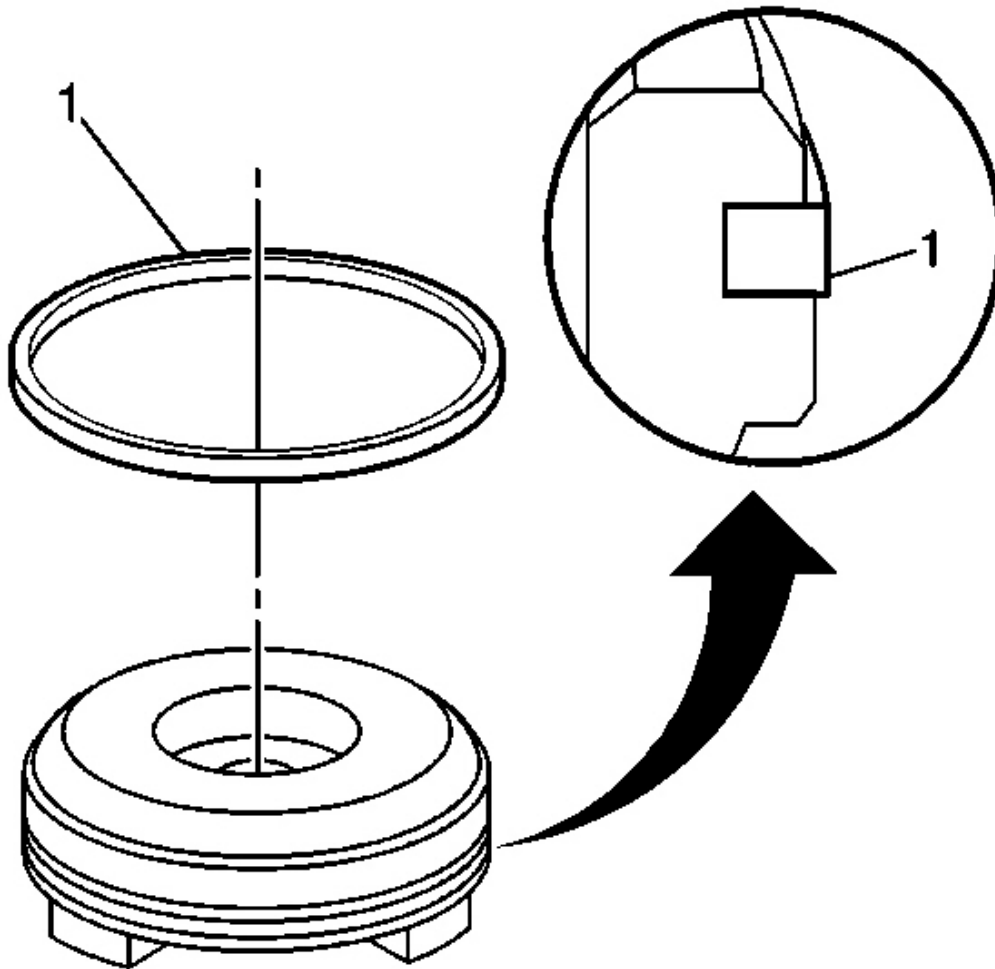

Fig. 157: View Of Accumulator Piston Seal & Accumulator Piston
Courtesy of GENERAL MOTORS CORP.

15. Remove the 3-4 accumulator piston seal (1) from the 3-4 accumulator piston.
16. Inspect the 3-4 accumulator piston for the following defects:
 - Porosity
 - Cracks
 - Scoring
 - Nicks and scratches

Installation Procedure

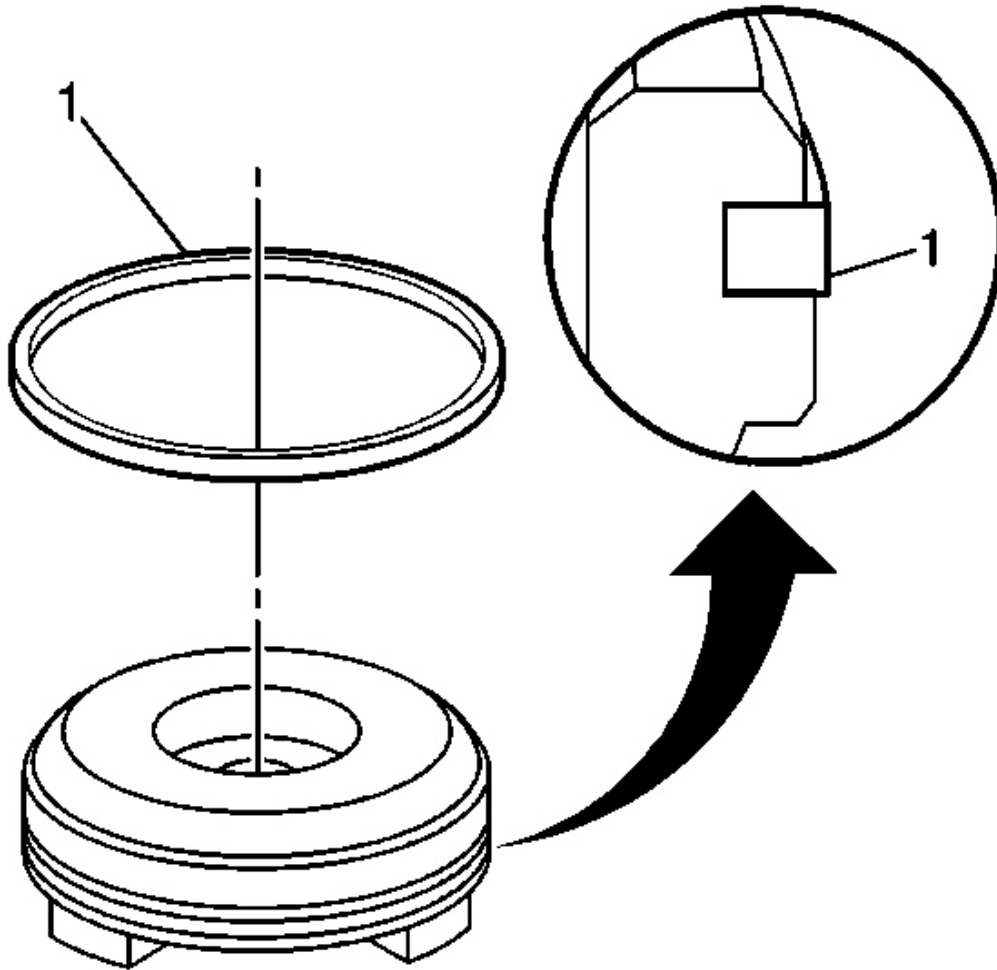

Fig. 158: View Of Accumulator Piston Seal & Accumulator Piston
Courtesy of GENERAL MOTORS CORP.

1. Install a new 3-4 accumulator piston seal (1) to the 3-4 accumulator piston.

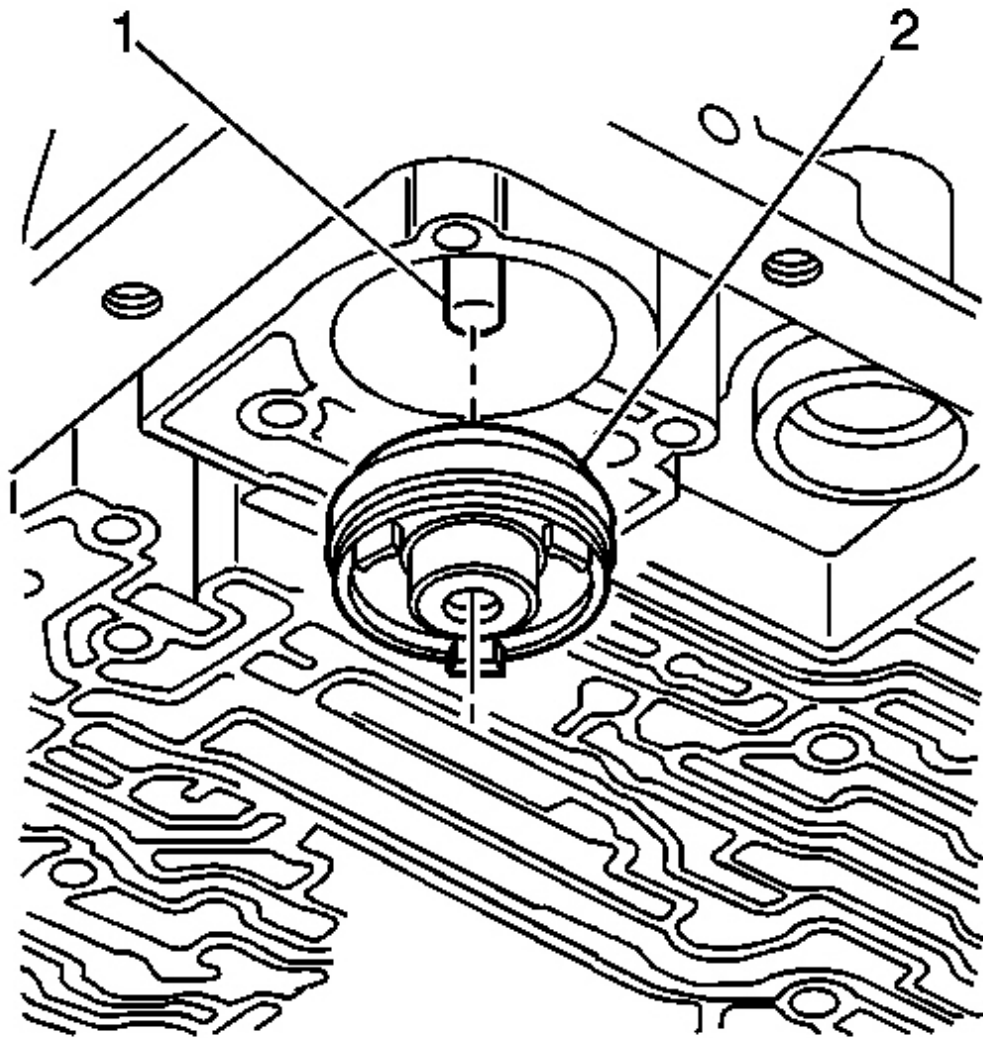

Fig. 159: Identifying 3-4 Accumulator Piston
Courtesy of GENERAL MOTORS CORP.

2. Install the 3-4 accumulator piston (2) onto the pin (1) in the transmission case.
Ensure that the 3-4 accumulator piston legs face away from the transmission case.

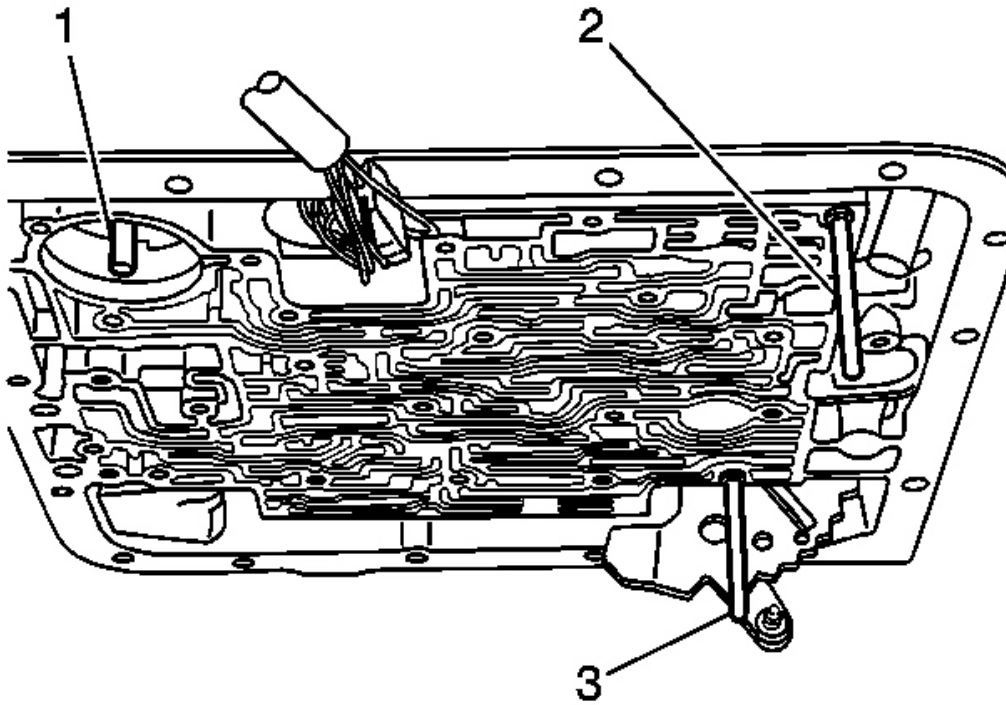

Fig. 160: Locating Transmission Case Components
Courtesy of GENERAL MOTORS CORP.

3. Install the **J 25025-B** (2, 3) to the transmission case. See **Special Tools**.

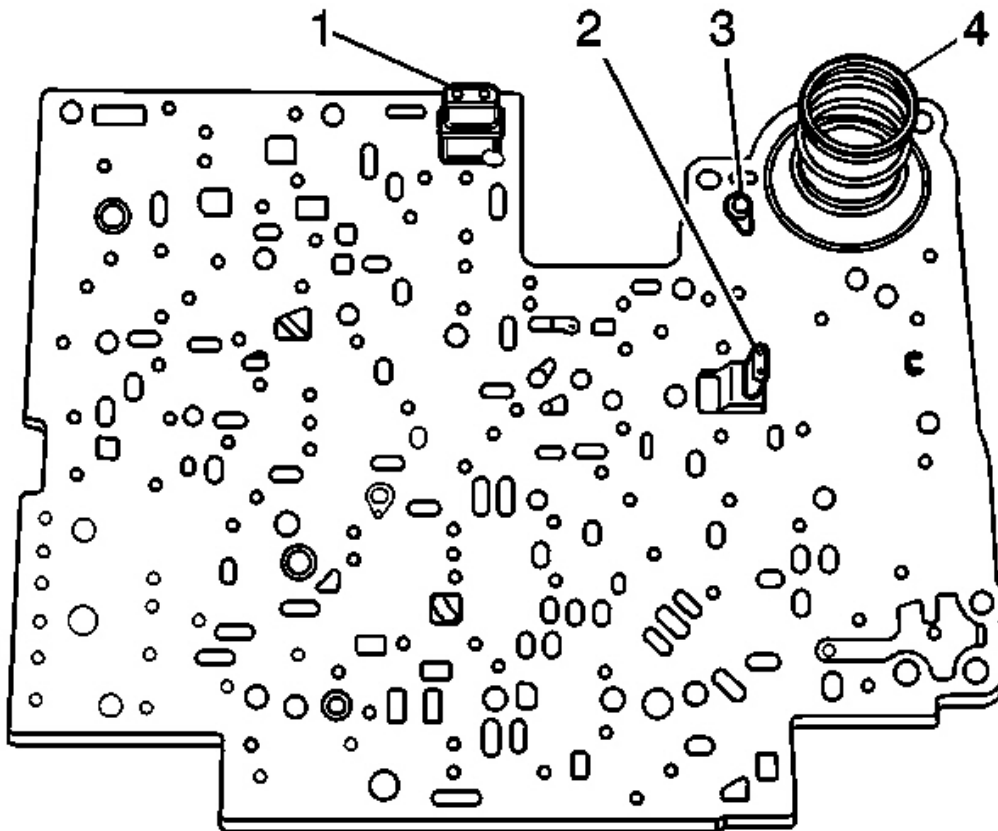

Fig. 161: Installing Spacer Plate Components
Courtesy of GENERAL MOTORS CORP.

4. Install the spacer plate to transmission case gasket and the spacer plate to valve body gasket to the spacer plate; use **J 36850** in order to retain the gaskets to the spacer plate.
 - The case gasket is identified by a C.

Be sure to place the case gasket on the transmission case side of the spacer plate.
 - The valve body gasket is identified by a V.

Be sure to place the valve body gasket on the valve body side of the spacer plate.
5. Ensure that the solenoid screens (1, 2) are in place on the spacer plate.

6. Use a small amount of **J 36850** in order to retain the checkball (3) on the spacer plate in the location shown.
7. Place the 3-4 accumulator spring (4) on the spacer plate.
8. Install the spacer plate and related components to the transmission.
9. Look through the hole in the spacer plate to ensure that the checkball has remained in the proper location (4WD only).

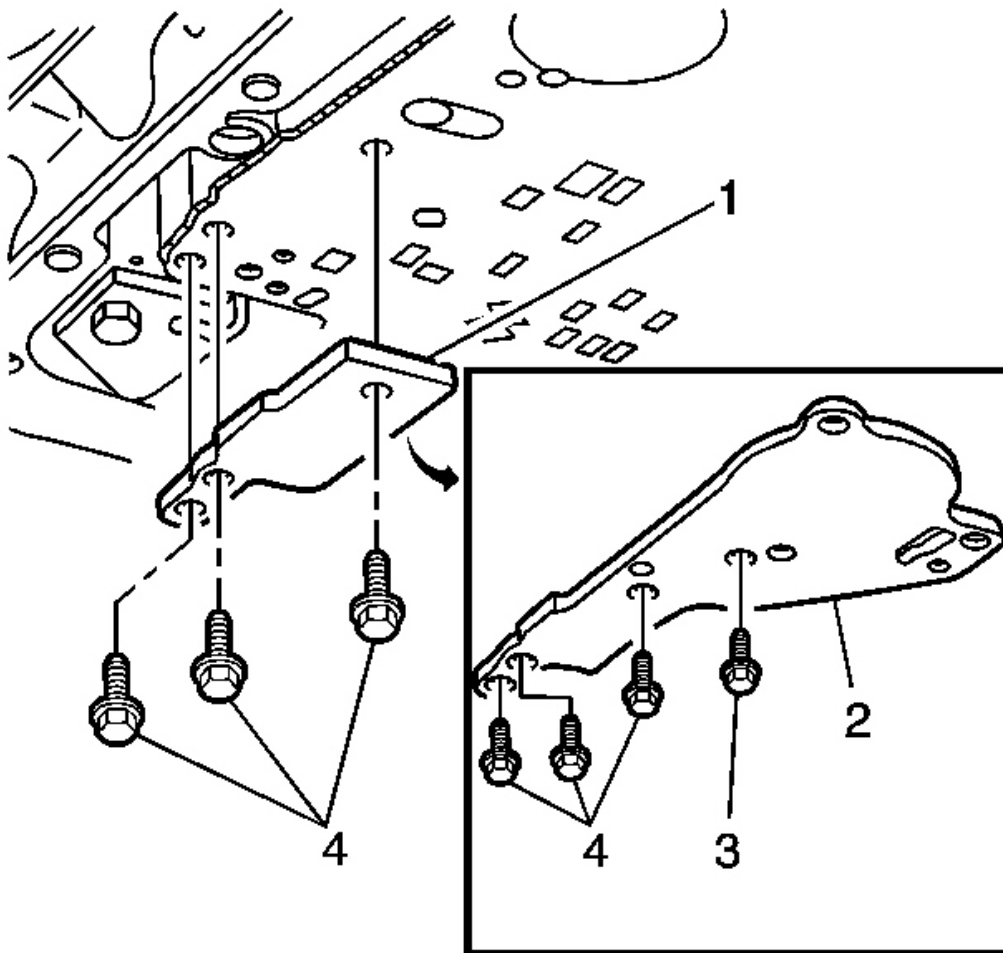

Fig. 162: View Of Spacer Plate Support Retaining Bolts
Courtesy of GENERAL MOTORS CORP.

NOTE: Refer to Fastener Notice .

10. Install the spacer plate support and the spacer plate support retaining bolts.

Tighten: Tighten the spacer plate support retaining bolts to 11 N.m (97 lb in).

- RWD (1)
- 4WD (2)

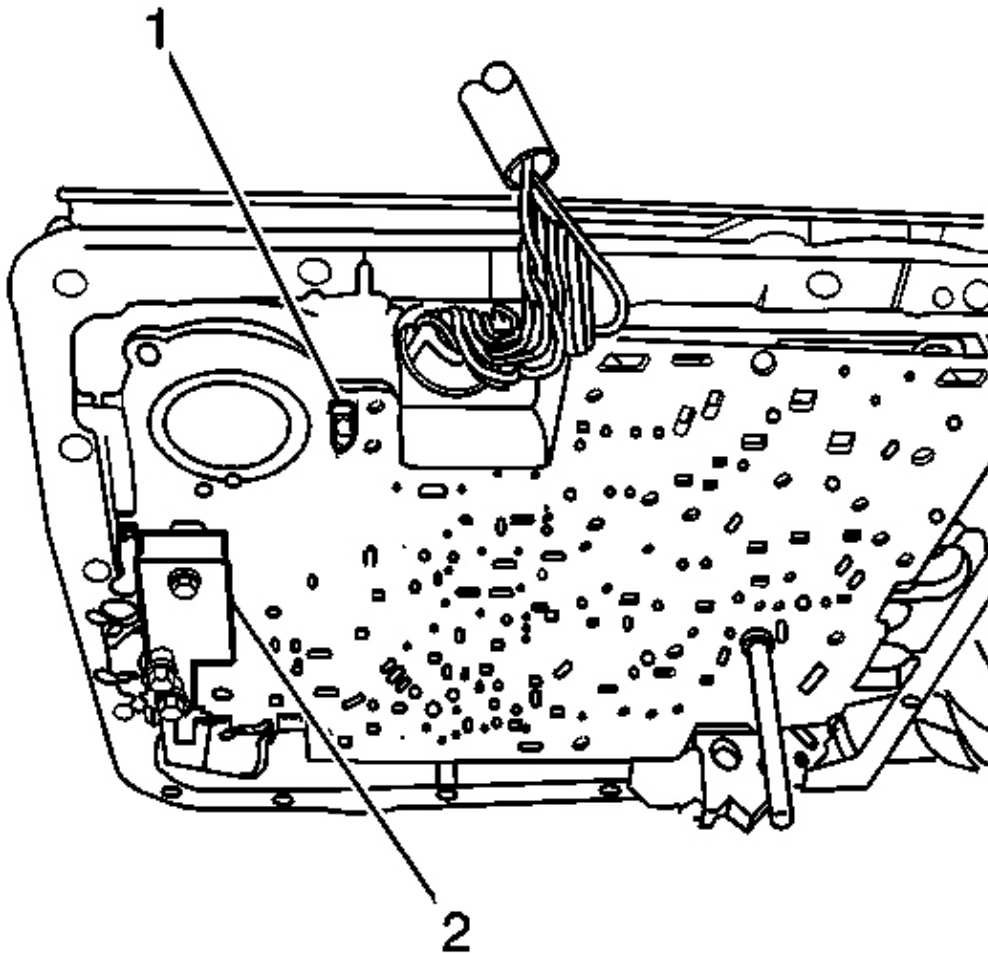

Fig. 163: View Of Spacer Plate Support And Checkball Location
Courtesy of GENERAL MOTORS CORP.

11. After installing the spacer plate support (2), look through the hole in the spacer plate to ensure that the checkball (1) has remained in the proper location (RWD only).

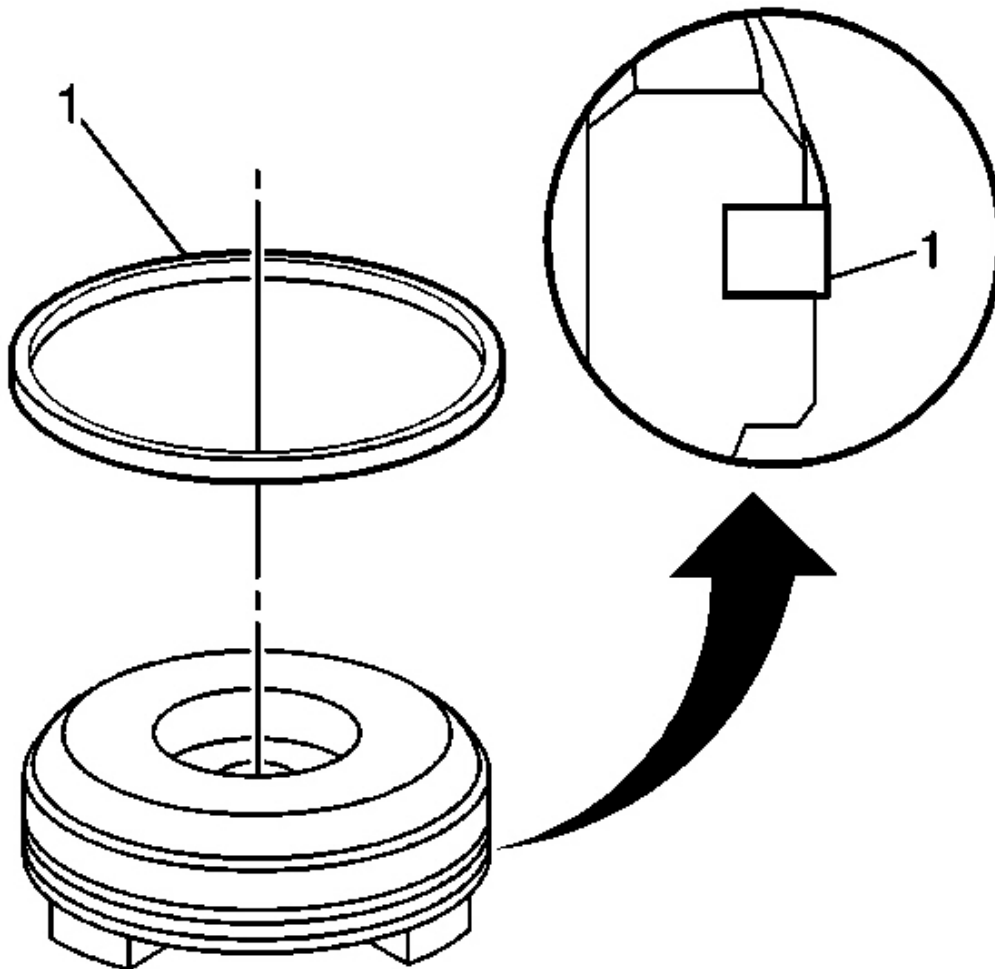

Fig. 164: View Of Accumulator Piston Seal & Accumulator Piston
Courtesy of GENERAL MOTORS CORP.

12. Install a new 1-2 accumulator piston seal (1) to the 1-2 accumulator piston.

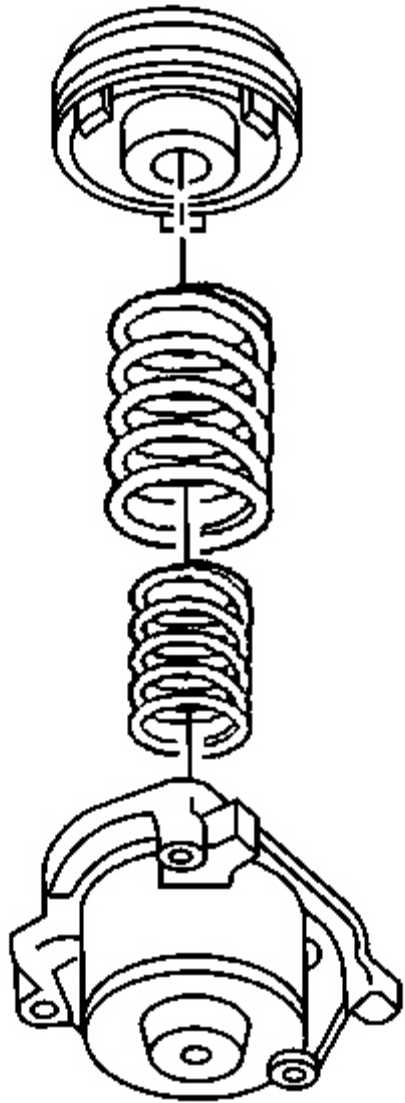

Fig. 165: 1-2 Accumulator, Inner And Outer Springs
Courtesy of GENERAL MOTORS CORP.

13. Install the 1-2 accumulator inner and outer springs to the 1-2 accumulator cover.
14. Install the 1-2 accumulator piston onto the pin in the 1-2 accumulator cover.

Ensure that the piston legs face the accumulator cover.

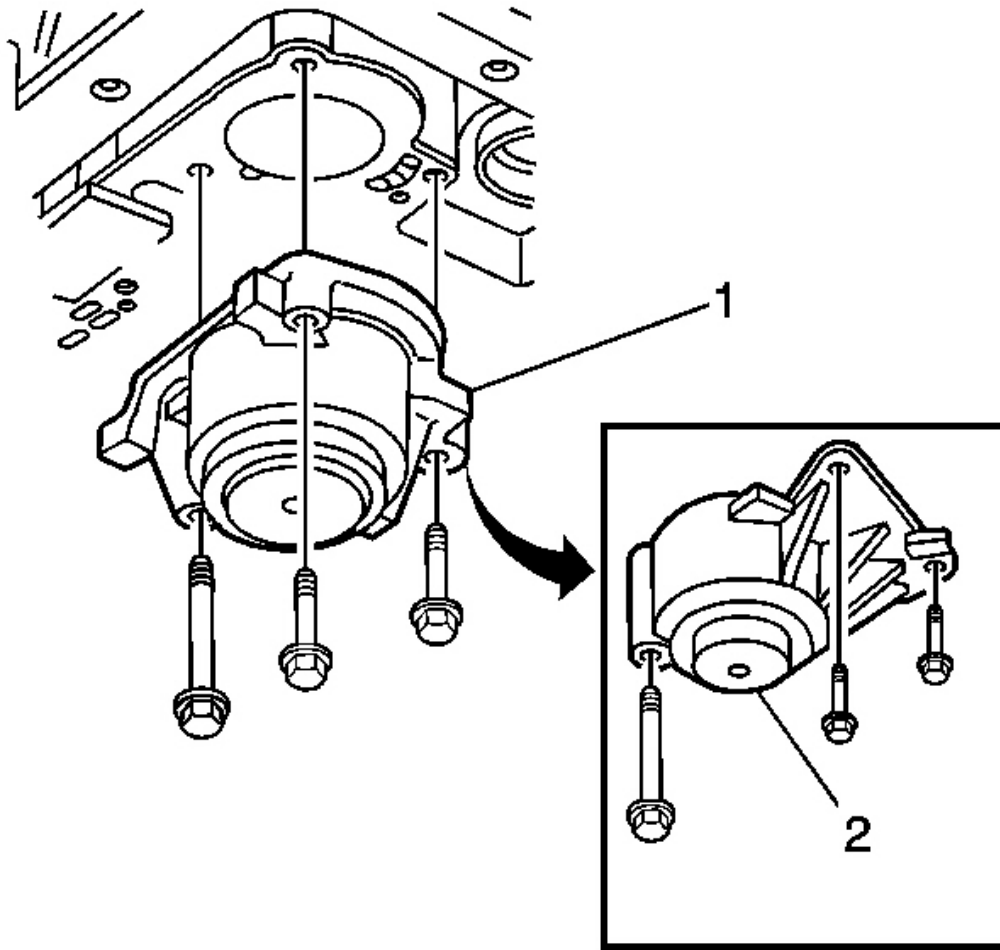

Fig. 166: View Of 1-2 Accumulator Cover Retaining Bolts
 Courtesy of GENERAL MOTORS CORP.

15. Install the 1-2 accumulator cover and the accumulator cover retaining bolts.

Tighten: Tighten the accumulator cover retaining bolts to 11 N.m (97 lb in).

- RWD (1)
- 4WD (2)

16. Remove the **J 25025-B** from the transmission case. See **Special Tools**.

17. Install the control valve body. Refer to **Valve Body and Pressure Switch Replacement**.

18. Install the transmission filter and oil pan. Refer to Automatic Transmission Fluid and Filter Replacement.

IMPORTANT: It is recommended that transmission adaptive pressure (TAP) information be reset.

Resetting the TAP values using a scan tool will erase all learned values in all cells. As a result, The ECM, PCM or TCM will need to relearn TAP values. Transmission performance may be affected as new TAP values are learned.

19. Reset the TAP values. Refer to Transmission Adaptive Functions.

VEHICLE SPEED SENSOR REPLACEMENT

Removal Procedure

1. Raise and support the vehicle. Refer to Lifting and Jacking the Vehicle .
2. Disconnect the wiring harness electrical connector from the vehicle speed sensor.

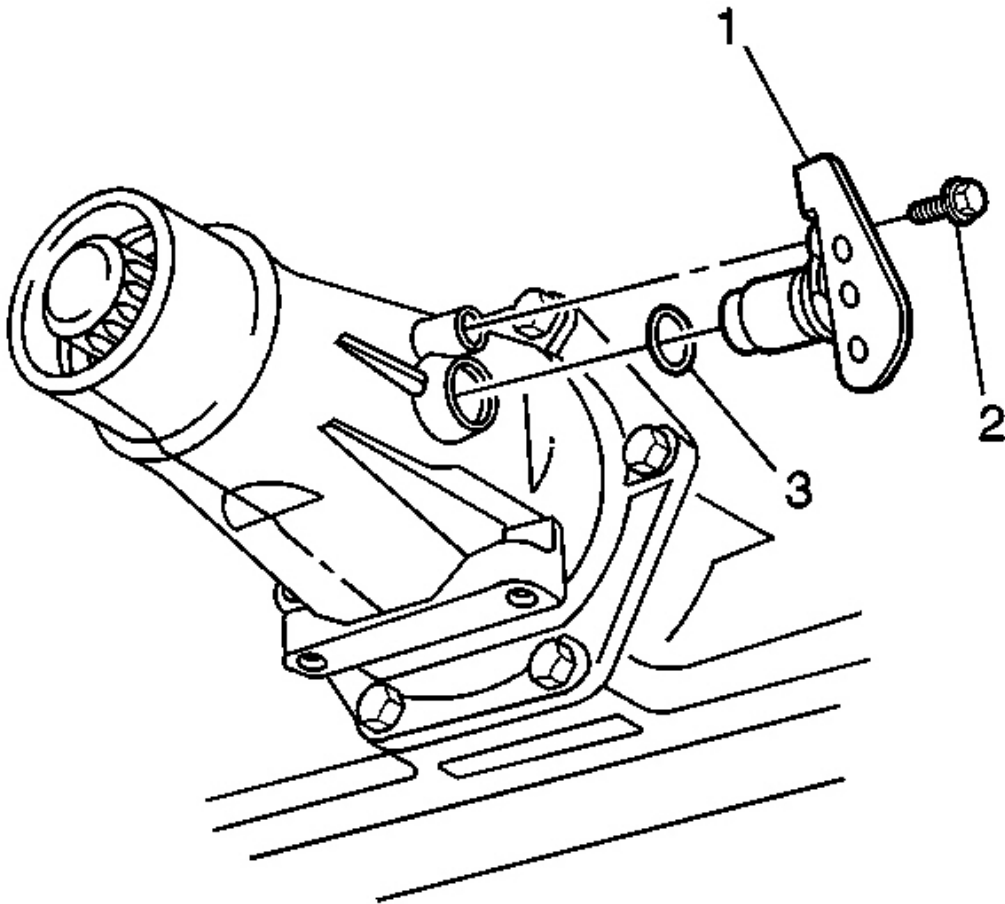

Fig. 167: View Of VSS, Bolt & O-Ring Seal
Courtesy of GENERAL MOTORS CORP.

3. Remove the harness connector.
4. Remove the bolt (2).
5. Remove the vehicle speed sensor (1).
6. Remove the O-ring seal (3).

Installation Procedure

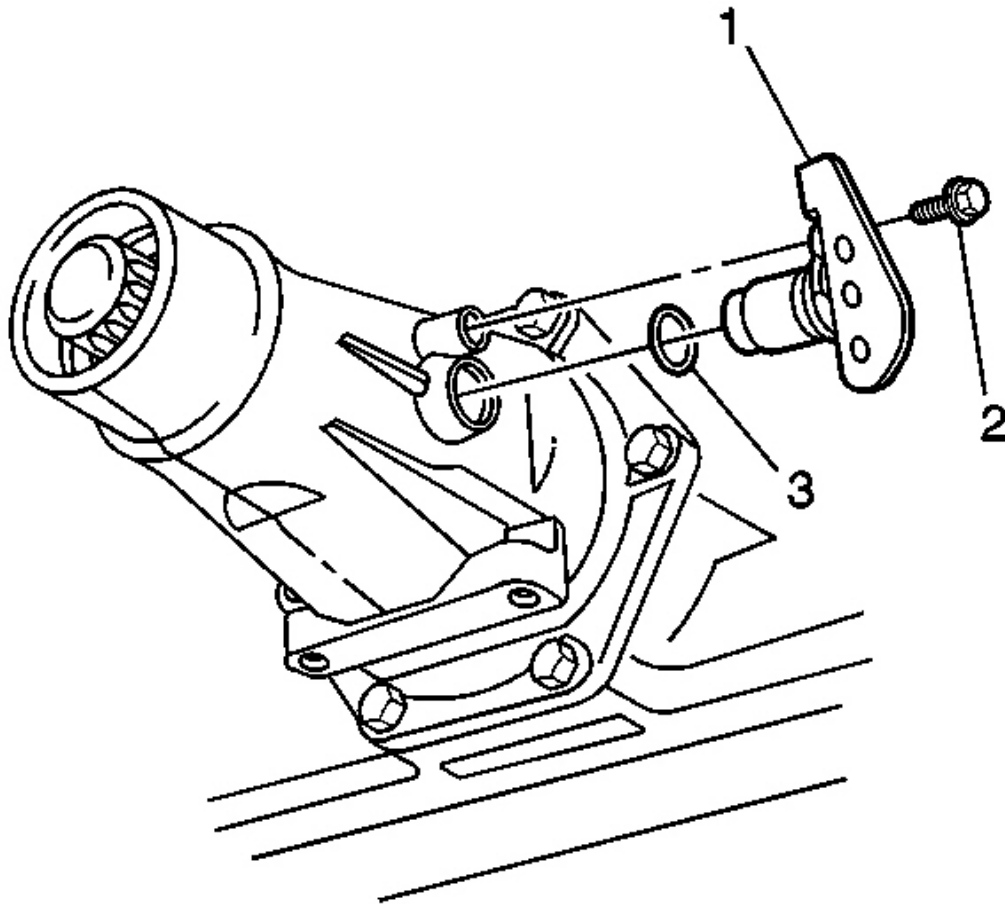

Fig. 168: View Of VSS, Bolt & O-Ring Seal
Courtesy of GENERAL MOTORS CORP.

1. Install the O-ring seal (3) on the vehicle speed sensor (1).
2. Coat the O-ring seal (3) with a thin film of transmission fluid.
3. Install the vehicle speed sensor (1) into the transmission case.

NOTE: Refer to Fastener Notice .

4. Install the bolt (2).

Tighten: Tighten the bolt to 11 N.m (97 lb in).

5. Connect the wiring harness electrical connector to the vehicle speed sensor.
6. Lower the vehicle.
7. Refill the fluid as required.

TRANSMISSION MOUNT REPLACEMENT

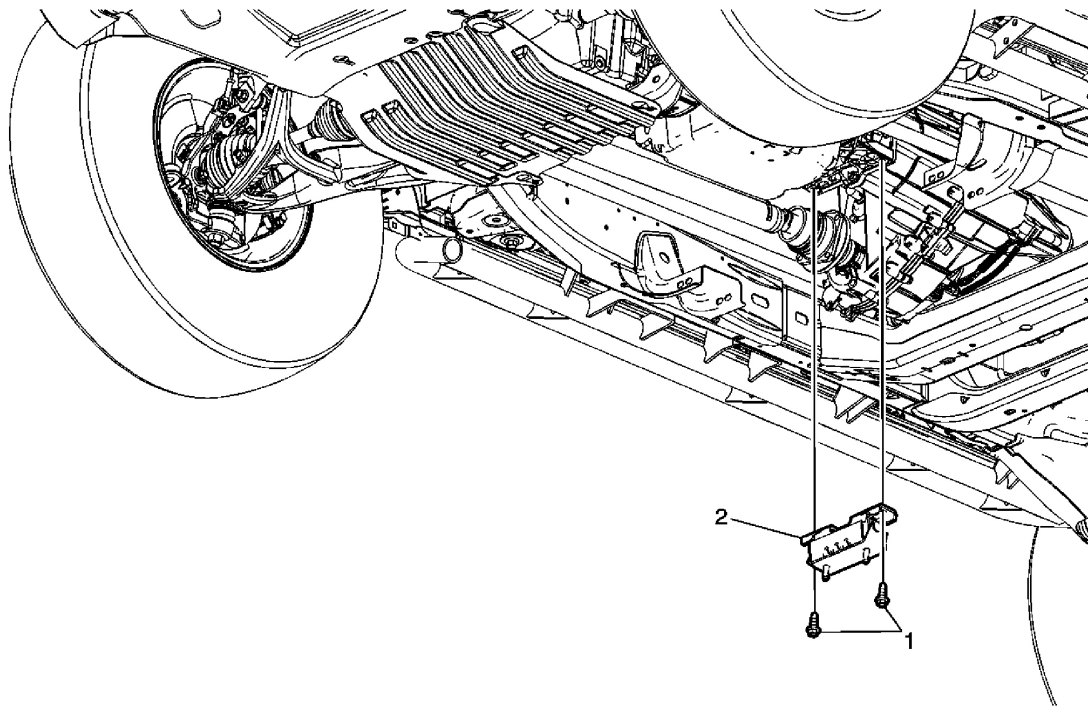

Fig. 169: Transmission Mount Replacement
 Courtesy of GENERAL MOTORS CORP.

Transmission Mount Replacement

Callout	Component Name
Preliminary Procedures	
<ol style="list-style-type: none"> 1. Raise the vehicle. Refer to <u>Lifting and Jacking the Vehicle</u> . 2. Remove the transfer case shield. Refer to <u>Transfer Case Shield Replacement</u> . 3. Remove the transmission crossmember. Refer to <u>Transmission Support Crossmember Replacement</u> . 	
1	Transmission Mount Bolt (Qty: 2) NOTE:

2007 Hummer H3

2007 TRANSMISSION Automatic Transmission - 4L60-E/4L65-E/4L70-E - H3

	Refer to <u>Fastener Notice</u> .
	Tighten: 50 N.m (37 lb ft)
2	Transmission Mount

TRANSMISSION REPLACEMENT

Tools Required

J 21366 Converter Holding Strap. See **Special Tools**.

Removal Procedure

1. Ensure the vehicle is in the park position.
2. Remove the filler tube. Refer to **Transmission Fluid Filler Tube and Seal Replacement**.
3. Drain the transmission fluid if necessary. Refer to **Automatic Transmission Fluid and Filter Replacement**.
4. Remove the transfer case assembly. Refer to **Transfer Case Assembly Replacement** .

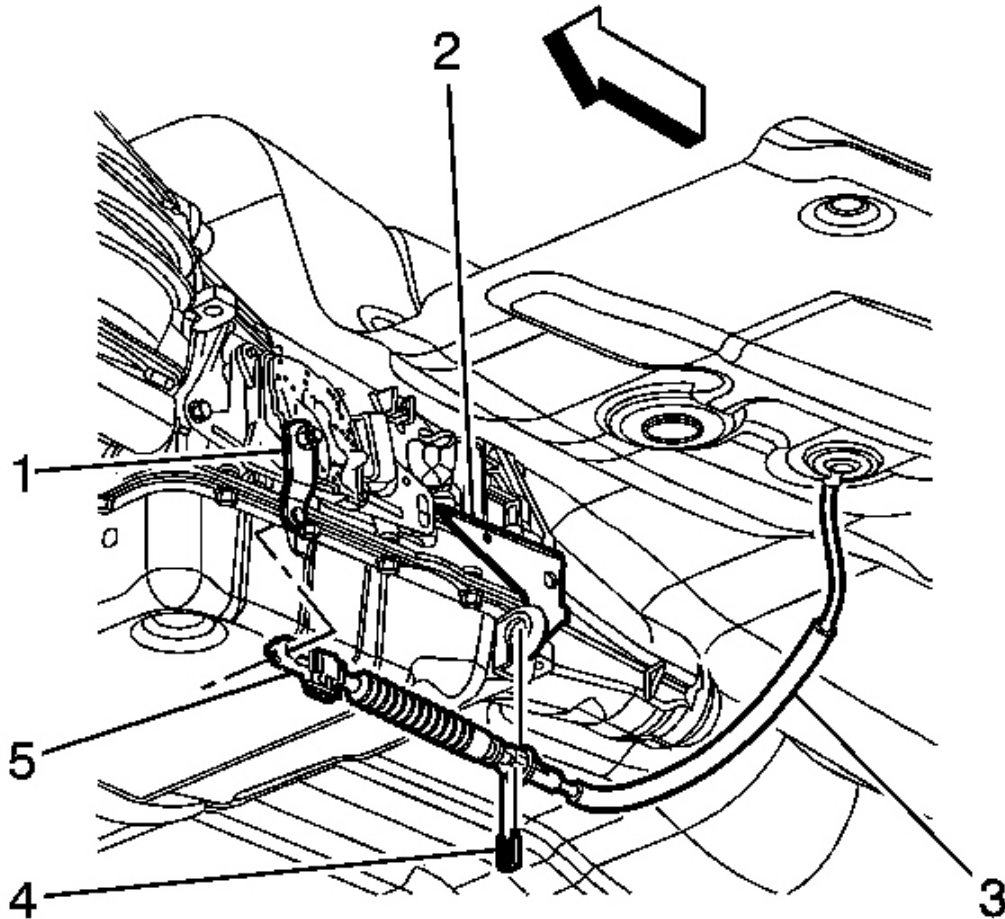

Fig. 170: View Of Range Selector Cable & Components
Courtesy of GENERAL MOTORS CORP.

IMPORTANT: Do not pull on the boot portion of the cable.

5. Complete the following in order to disconnect the range selector cable (3) from the transmission range selector lever ball stud.
 1. Insert a flat-bladed tool between the range selector cable end (5) and the range selector lever (1).
 2. Pry the range selector cable end (5) away from the range selector lever (1).
6. Remove the retainer (4) from the range selector cable (3).

7. Push the range selector cable locking tabs inward toward each other to release from the bracket (2).

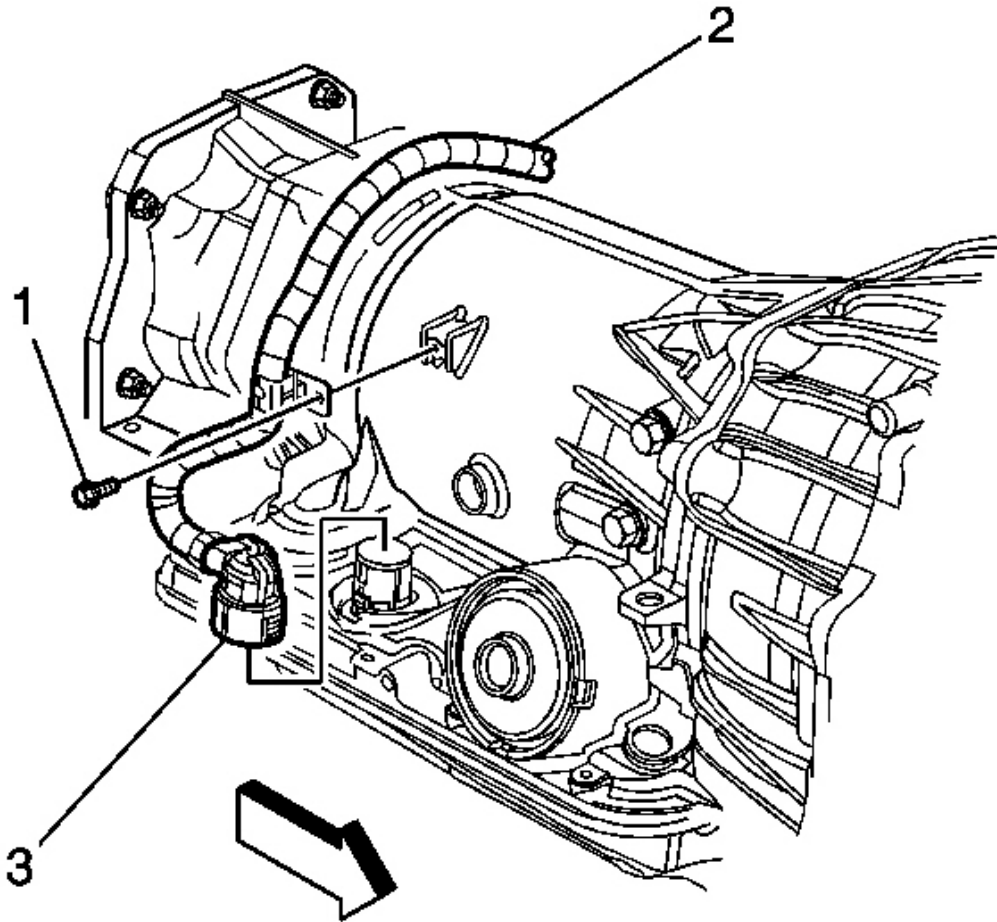

Fig. 171: View Of Screw, Engine Wiring Harness And Transmission Main Electrical Connector

Courtesy of GENERAL MOTORS CORP.

8. Disconnect the transmission main electrical connector (3).
9. Remove the screw (1) securing the engine wiring harness (2) to the right side of the transmission and position the harness over the transmission.

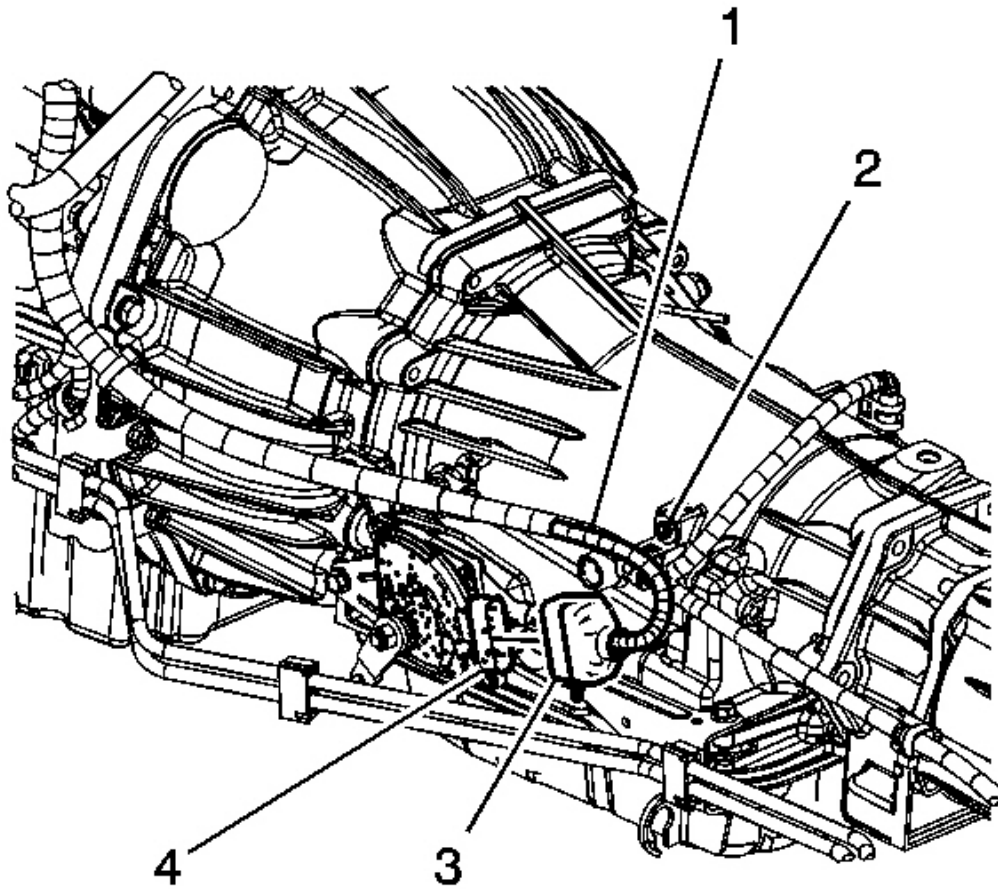

Fig. 172: View Of park/neutral back up switch, harness, electrical connector and screw

Courtesy of GENERAL MOTORS CORP.

10. Disconnect the park/neutral back up switch electrical connector (3).
11. Remove the screw (2) securing the engine wiring harness (1) to the left side of the transmission and position the wiring harness aside.

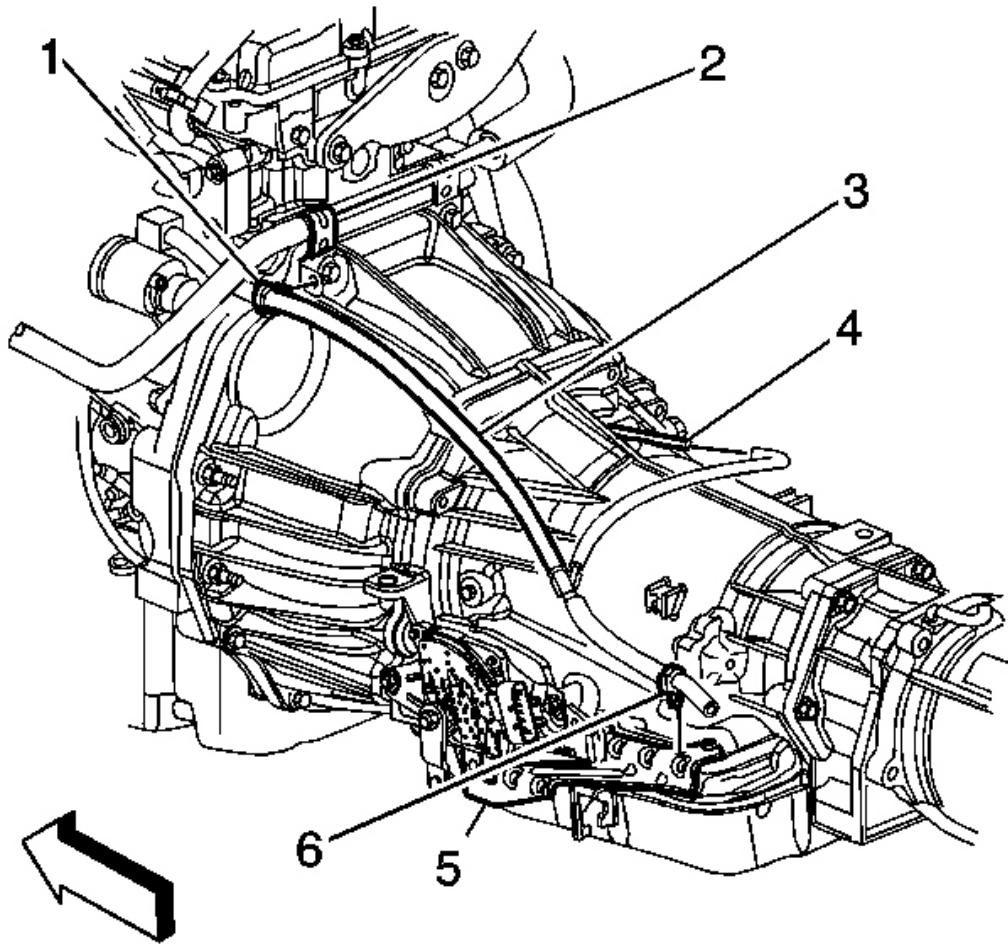

Fig. 173: View Of Transmission Vent Hose & Retainers
Courtesy of GENERAL MOTORS CORP.

12. Disconnect the transmission vent hose retainer (1) from the heater pipe bracket (2).

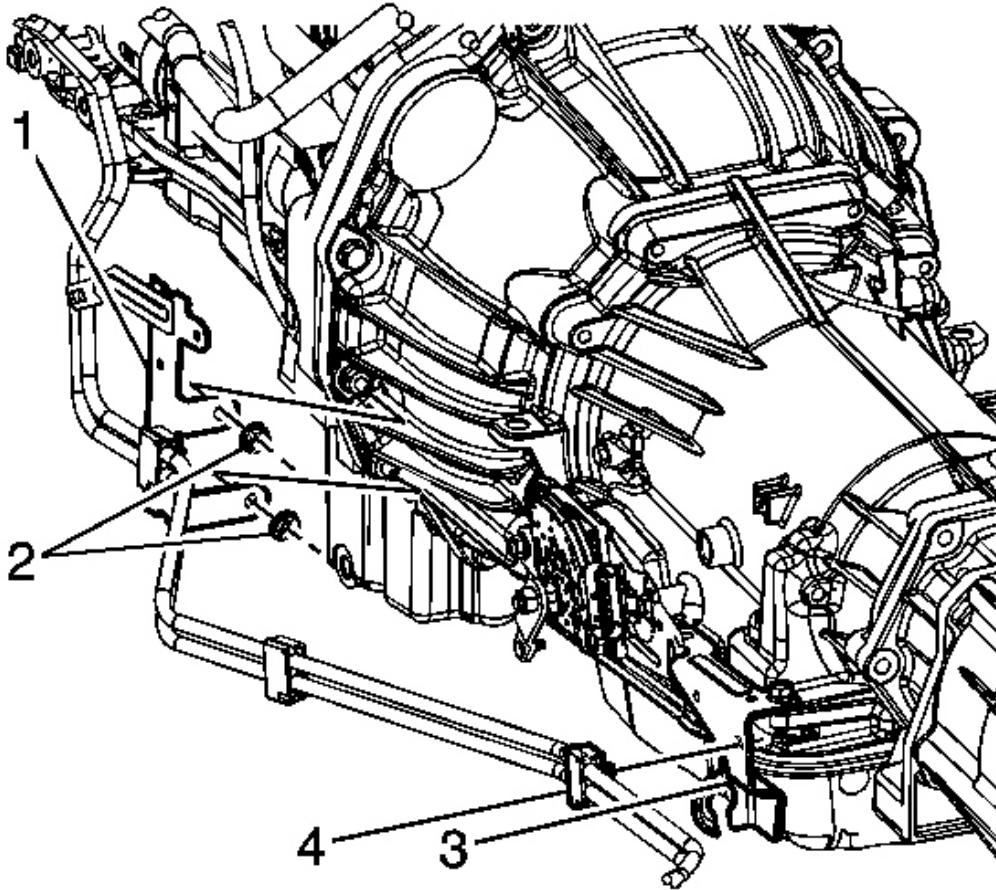

Fig. 174: Identifying Fuel Hose/Pipe Bracket & Nuts
Courtesy of GENERAL MOTORS CORP.

13. Remove the nuts (2) securing the fuel hose/pipe bracket (1) to the transmission.
14. Disconnect the fuel hose/pipe retainer (4) from the range selector cable bracket (3) and position aside the fuel hose/pipe bundle.

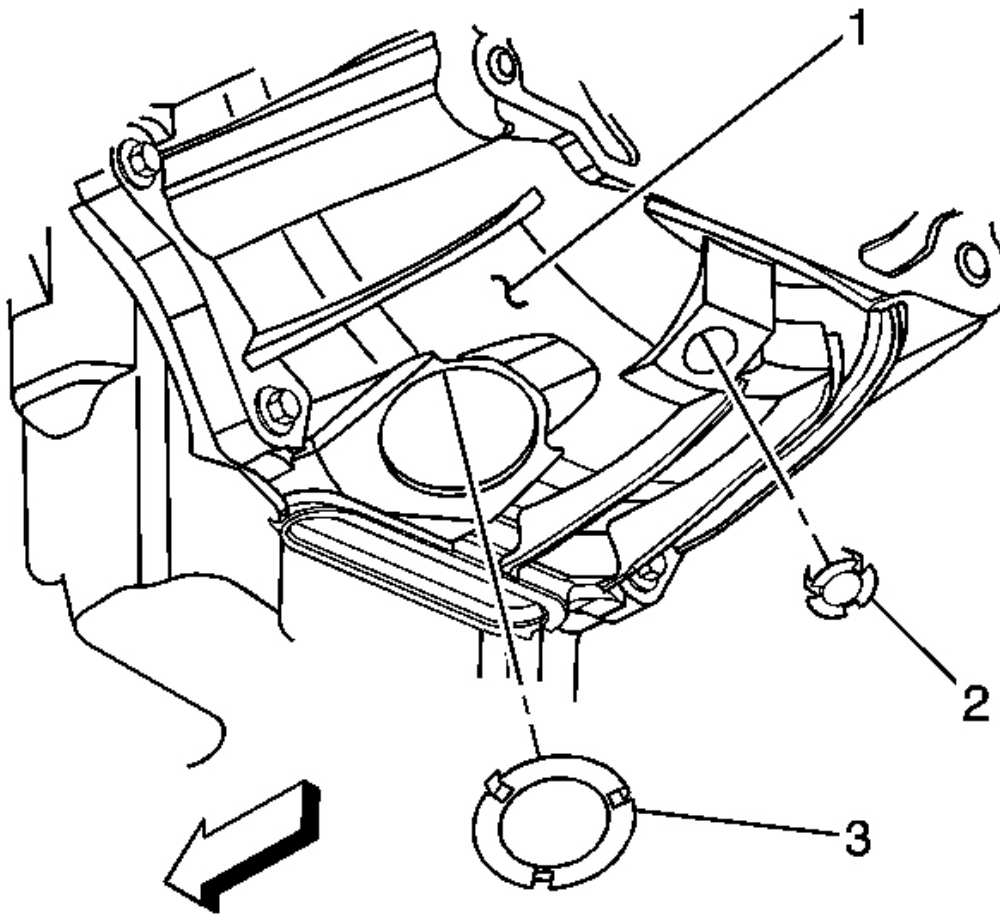

Fig. 175: View Of Inspection Plug
Courtesy of GENERAL MOTORS CORP.

15. Remove the inspection plug (3) from the transmission (1).
16. Mark the torque converter to flexplate/flywheel orientation to ensure proper realignment.
17. Remove the engine protection shield in order to access the harmonic balancer bolt. Refer to **Oil Pan Skid Plate Replacement** .

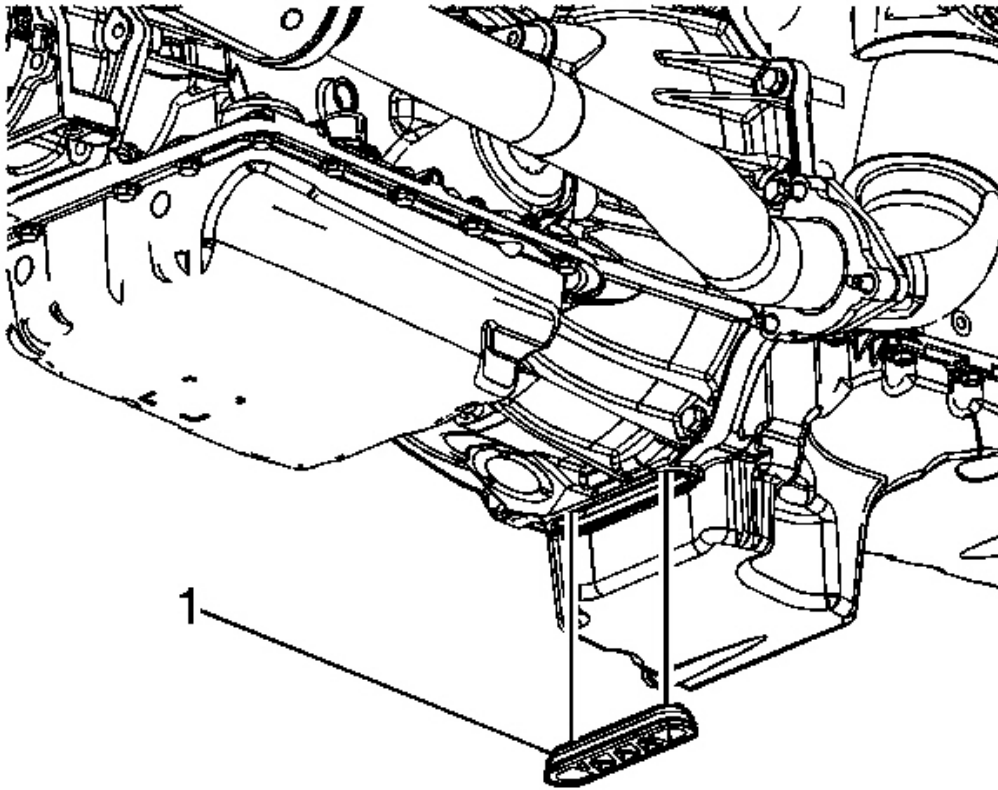

Fig. 176: Locating Service Slot Plug
Courtesy of GENERAL MOTORS CORP.

18. Remove the service slot plug (1).
19. Repeat the following steps for all 3 torque converter bolts:
 - Rotate the harmonic balancer center bolt clockwise ONLY, in order to access the torque converter bolt through the service slot.
 - Remove the torque converter bolt using one of the following:
 - 18 mm crowfoot wrench
 - Short T50 TORX bit
20. Place an oil pan under the transmission fluid cooler pipes.
21. Disconnect the transmission oil cooler pipes from the transmission ONLY. Refer to **Transmission Fluid Cooler Hose/Pipe Replacement**.

22. Plug the open outlet ports to prevent fluid loss and contamination.
23. Support and secure the transmission using a suitable transmission jack.
24. Remove the transmission crossmember. Refer to **Transmission Support Crossmember Replacement** .

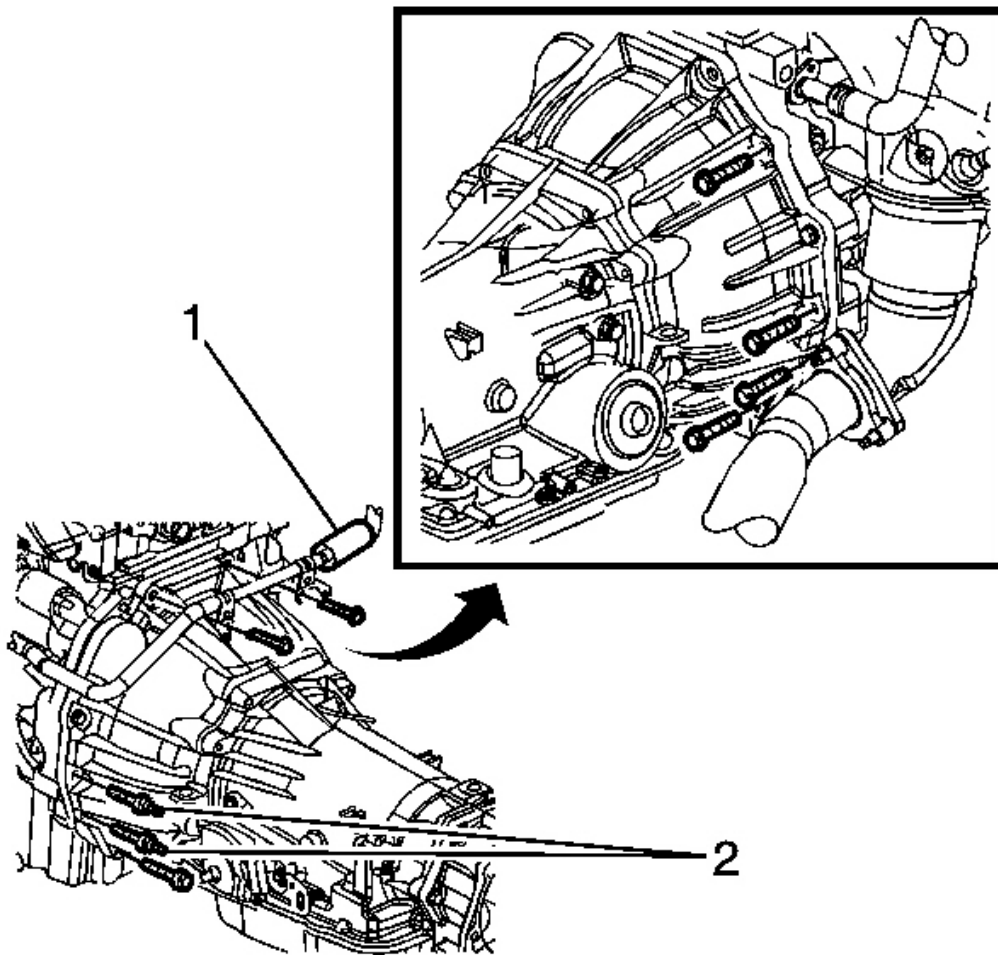

Fig. 177: Identifying Transmission Mounting Bolts
Courtesy of GENERAL MOTORS CORP.

25. Remove the 7 transmission mounting bolts and 2 studded mounting bolts (2).
26. Position the heater pipe (1) out of the way to allow clearance for the transmission.

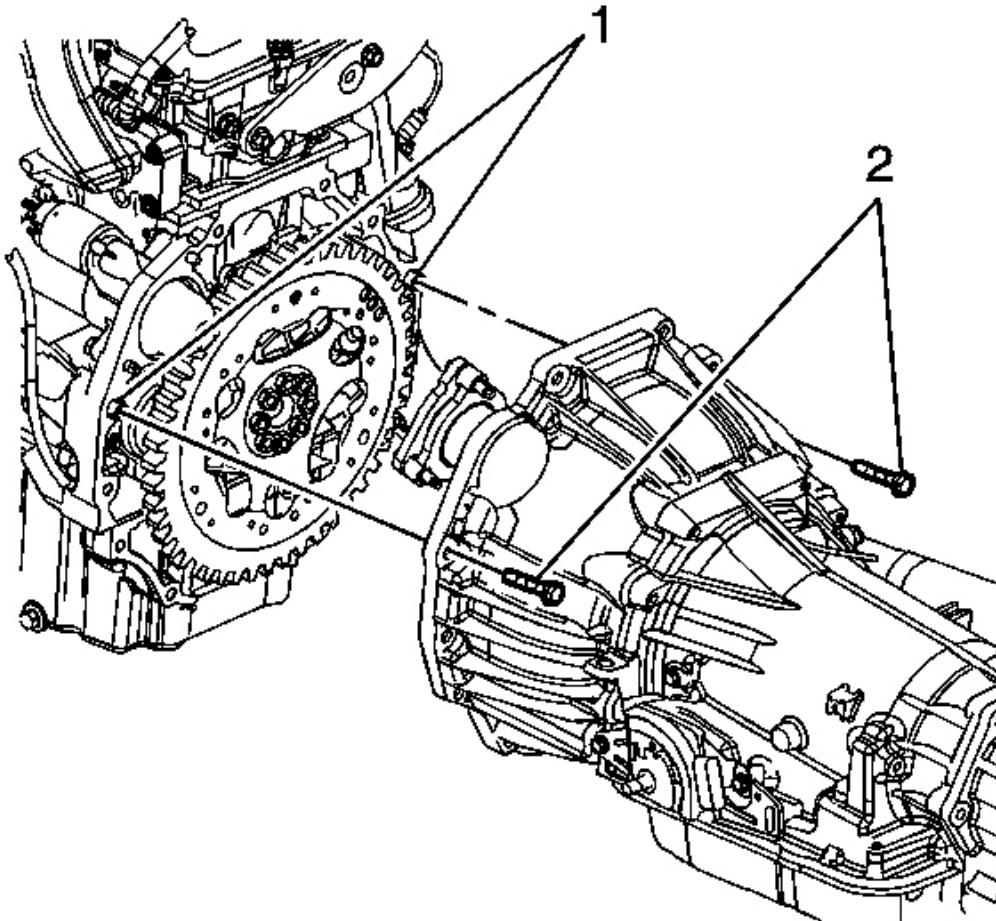

Fig. 178: Identifying Engine Alignment Dowels
Courtesy of GENERAL MOTORS CORP.

27. Remove the remaining transmission mounting bolts (2).
28. Separate the transmission from the engine alignment dowels (1).

IMPORTANT: Ensure clearance is maintained between the transmission and the following:

- The catalytic converter
- The engine wiring harness

2007 Hummer H3

2007 TRANSMISSION Automatic Transmission - 4L60-E/4L65-E/4L70-E - H3

- The fuel hose/pipe brackets
- The heater pipe
- The transmission oil cooler pipes

29. Using the transmission jack, carefully lower the transmission from the vehicle.

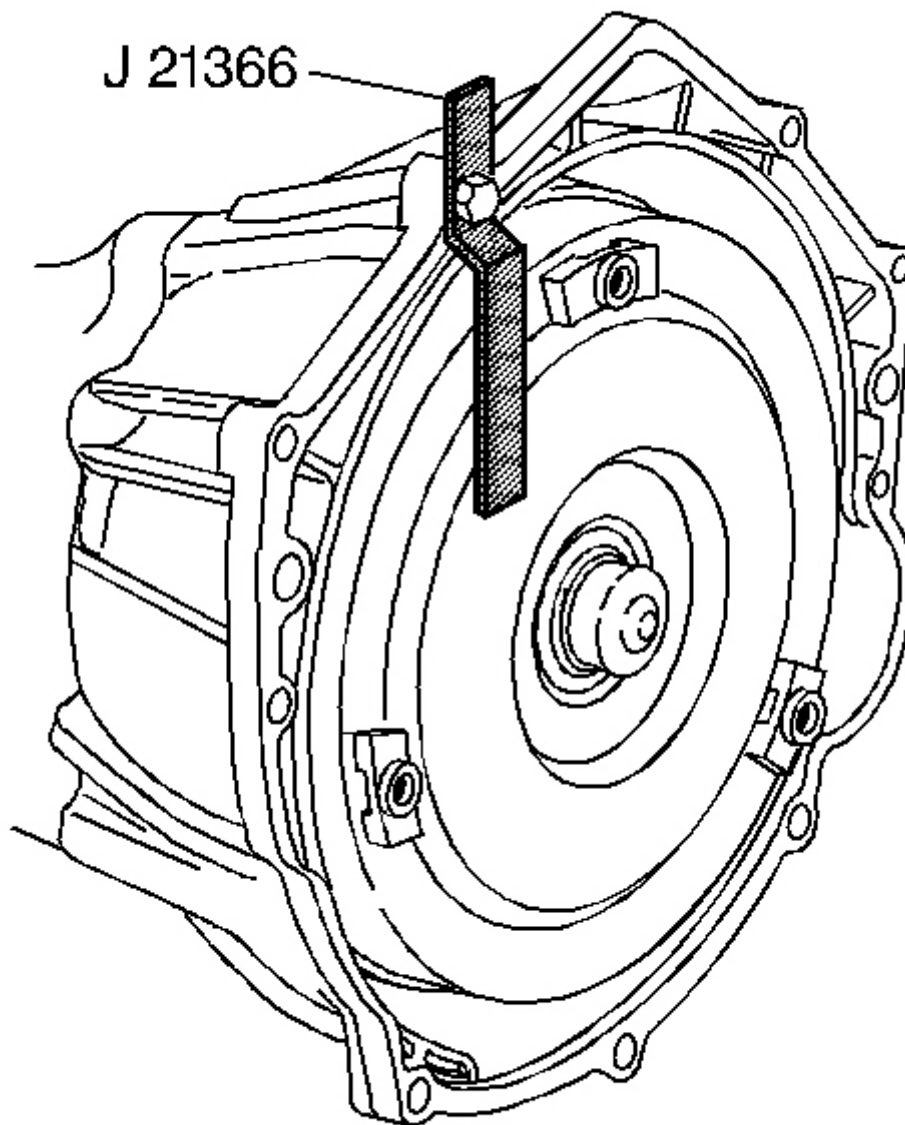

Fig. 179: View Of J 21366 Installed On Torque Converter
Courtesy of GENERAL MOTORS CORP.

30. Install the **J 21366** onto the transmission bell housing to retain the torque converter. See **Special Tools**.
31. Perform the flush and flow test on the automatic transmission oil cooler. Refer to **Transmission Fluid Cooler Flushing and Flow Test (J 45096)** or **Transmission Fluid Cooler Flushing and Flow Test (J 35944-A)**.

Installation Procedure

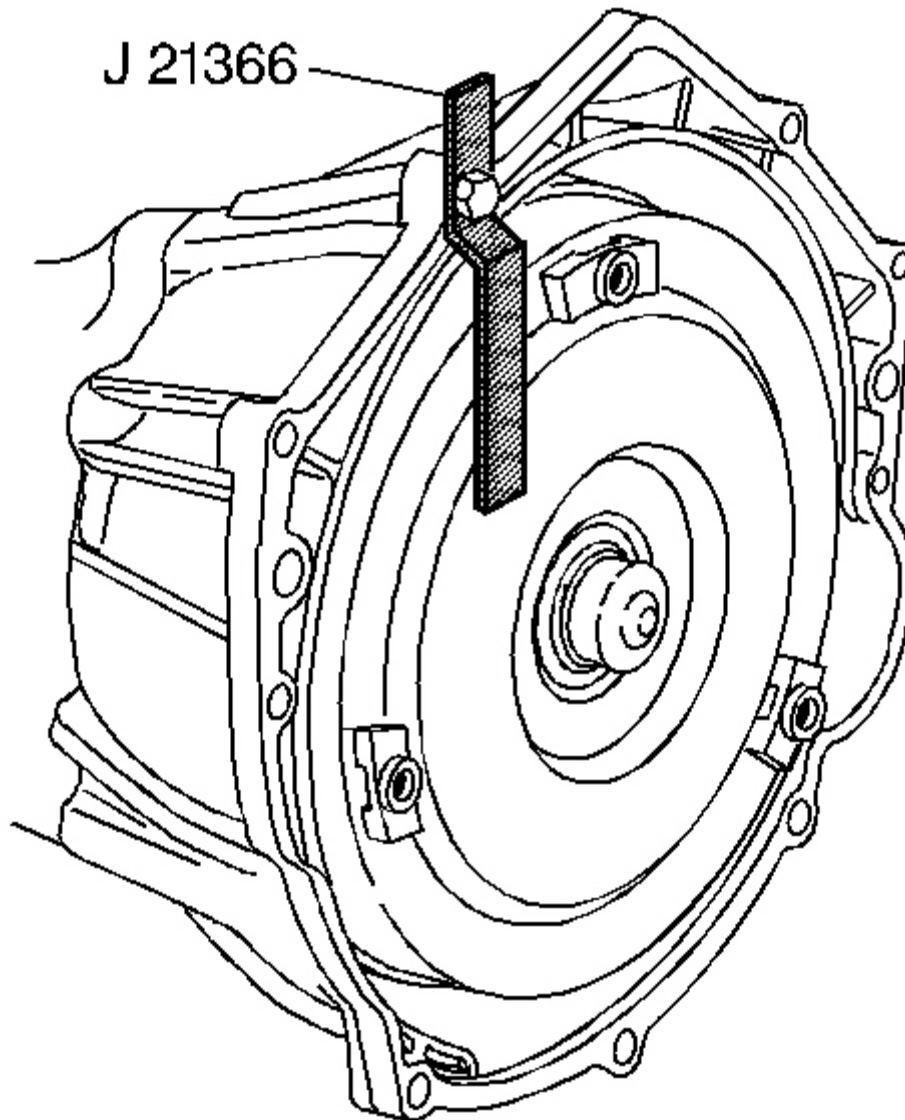

Fig. 180: View Of J 21366 Installed On Torque Converter
Courtesy of GENERAL MOTORS CORP.

1. Remove the **J 21366** from the transmission. See **Special Tools**.
2. Ensure the torque converter is fully engaged with the transmission oil pump.

IMPORTANT: Ensure clearance is maintained between the transmission and the following:

- The catalytic converter
- The engine wiring harness
- The fuel hose/pipe brackets
- The heater pipe
- The transmission oil cooler pipes

3. Using the transmission jack, carefully raise the transmission to the engine.

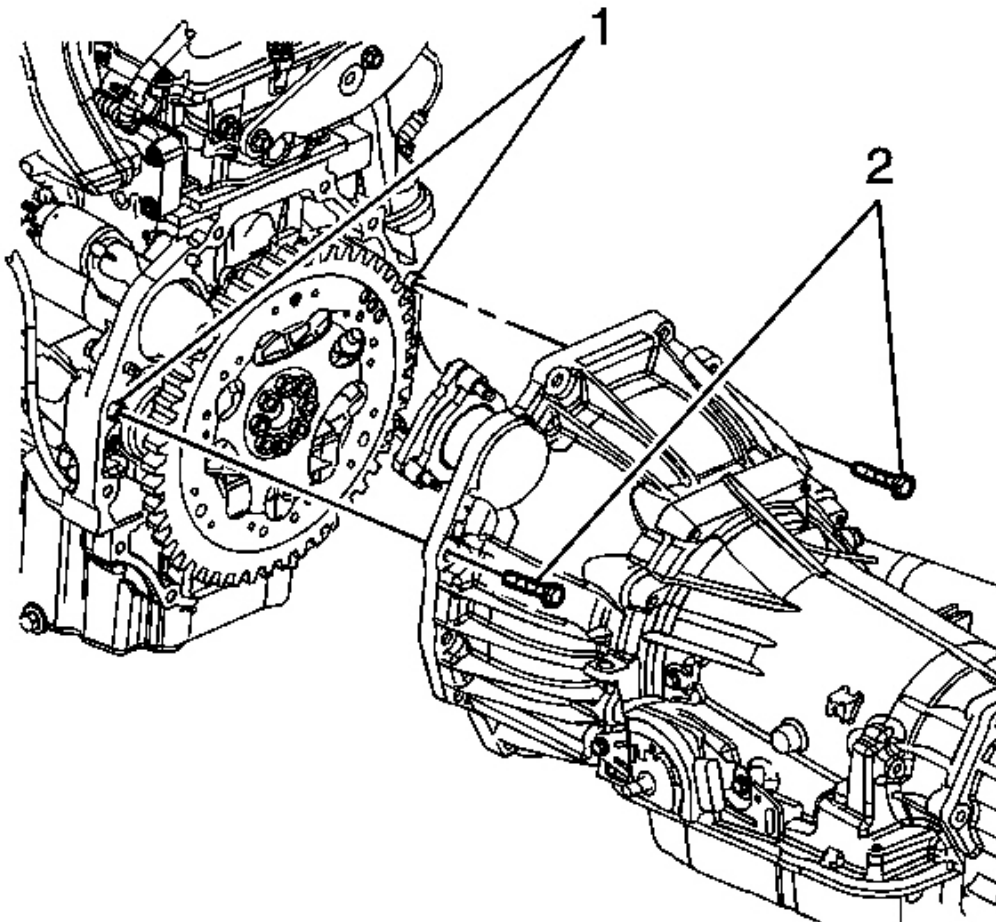

Fig. 181: Identifying Engine Alignment Dowels
Courtesy of GENERAL MOTORS CORP.

4. Align the transmission with the engine alignment dowels (1).

NOTE: Refer to Fastener Notice .

IMPORTANT: Ensure the torque converter turns freely while tightening the transmission mounting bolts.

5. Install the 2 transmission mounting bolts (2).

Tighten: Tighten the transmission mounting bolts to 50 N.m (37 lb ft).

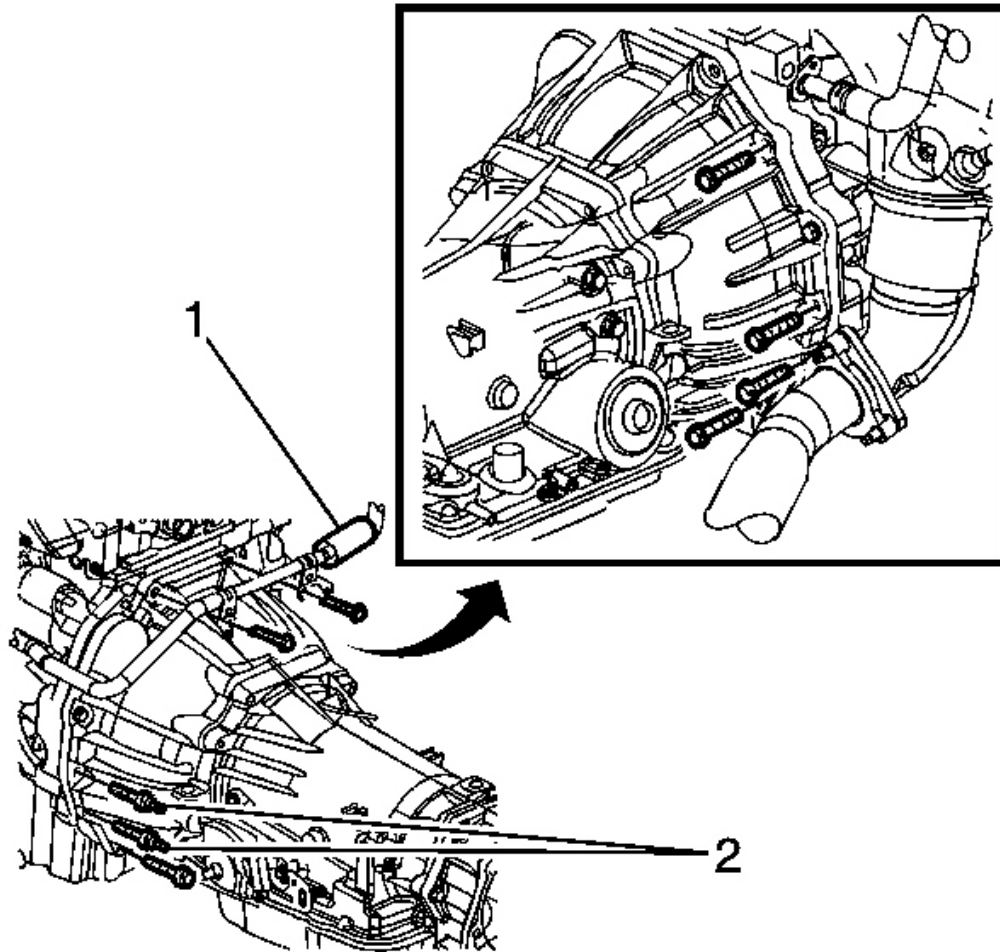

Fig. 182: Identifying Transmission Mounting Bolts
Courtesy of GENERAL MOTORS CORP.

IMPORTANT:

- Ensure the studded mounting bolts (2) are located in the correct position.
- The heater pipe (1) must be secured with the 2 upper mounting bolts.

6. Install the remaining 7 transmission mounting bolts and 2 studded mounting bolts (2).

Tighten: Tighten the transmission mounting bolts to 50 N.m (37 lb ft).

2007 Hummer H3

2007 TRANSMISSION Automatic Transmission - 4L60-E/4L65-E/4L70-E - H3

7. Install the transmission crossmember. Refer to **Transmission Support Crossmember Replacement** .
8. Remove the transmission jack from under the vehicle.
9. Connect the transmission oil cooler pipes to the transmission. Refer to **Transmission Fluid Cooler Hose/Pipe Replacement**.
10. Align the torque converter to flexplate/flywheel orientation marks made during the removal procedure.
11. Repeat the following steps for all 3 torque converter bolts:
 1. Rotate the harmonic balancer center bolt clockwise ONLY, in order to access the torque converter bolt holes in the flexplate/flywheel through the service slot.
 2. To aid in alignment of the torque converter to the flexplate/flywheel. Install all 3 torque converter bolts before fully tightening using one of the following:

Tighten: Tighten the torque converter bolts to 60 N.m (44 lb ft).

- 18 mm crowfoot wrench
- Short T50 TORX bit

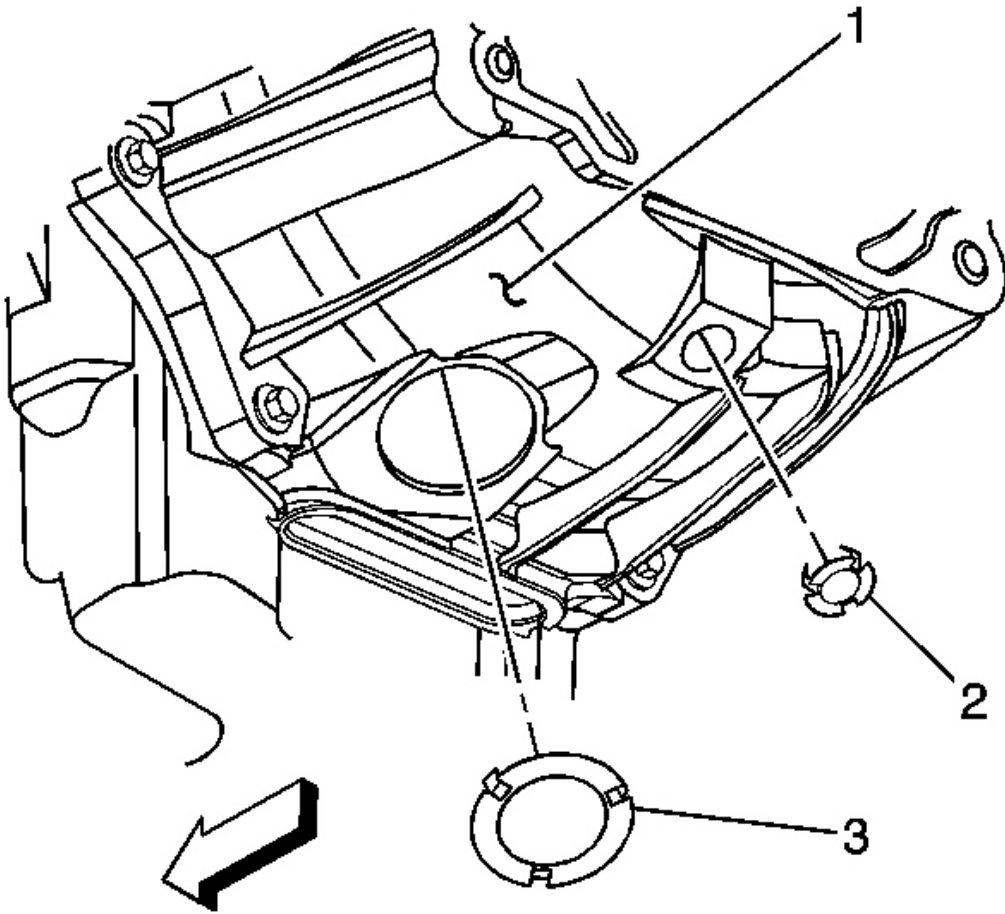

Fig. 183: View Of Inspection Plug
Courtesy of GENERAL MOTORS CORP.

12. Install the inspection plug (3) to the transmission (1).

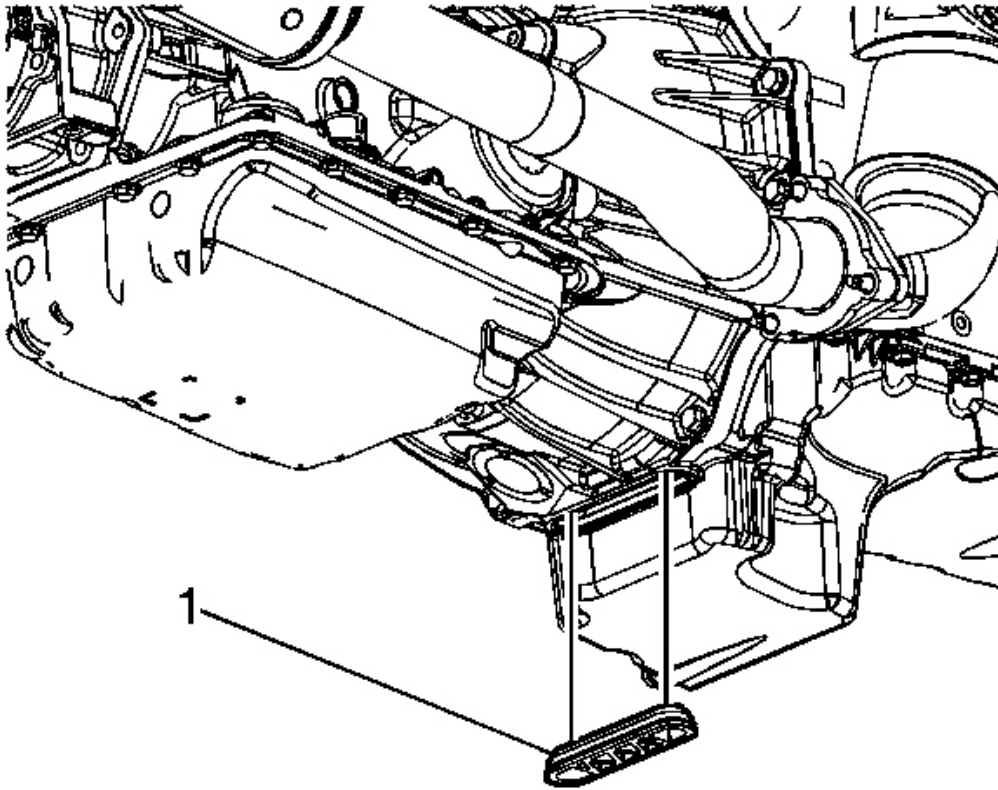

Fig. 184: Locating Service Slot Plug
Courtesy of GENERAL MOTORS CORP.

13. Install the service slot plug (1).

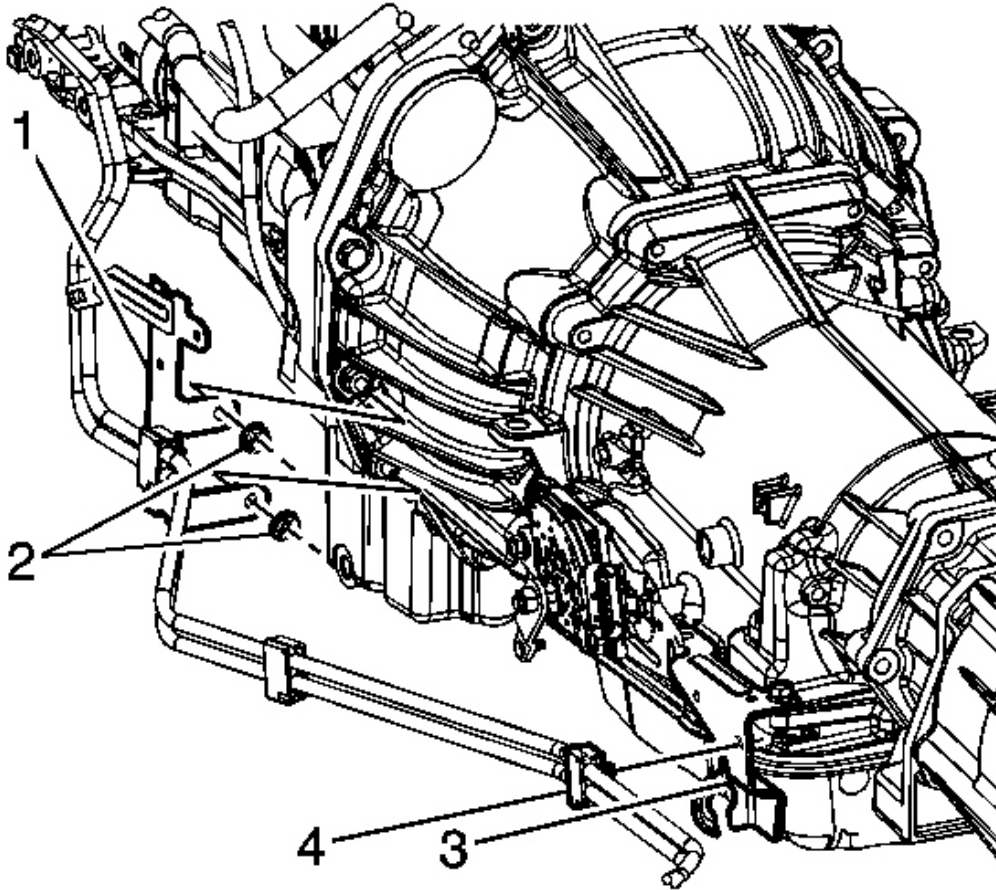

Fig. 185: Identifying Fuel Hose/Pipe Bracket & Nuts
Courtesy of GENERAL MOTORS CORP.

14. Install the nuts (2) securing the fuel hose/pipe bracket (1) to the transmission.

Tighten: Tighten the fuel hose/pipe bracket nuts to 20 N.m (15 lb ft).

15. Connect the fuel hose/pipe retainer (4) to the range selector cable bracket (3).

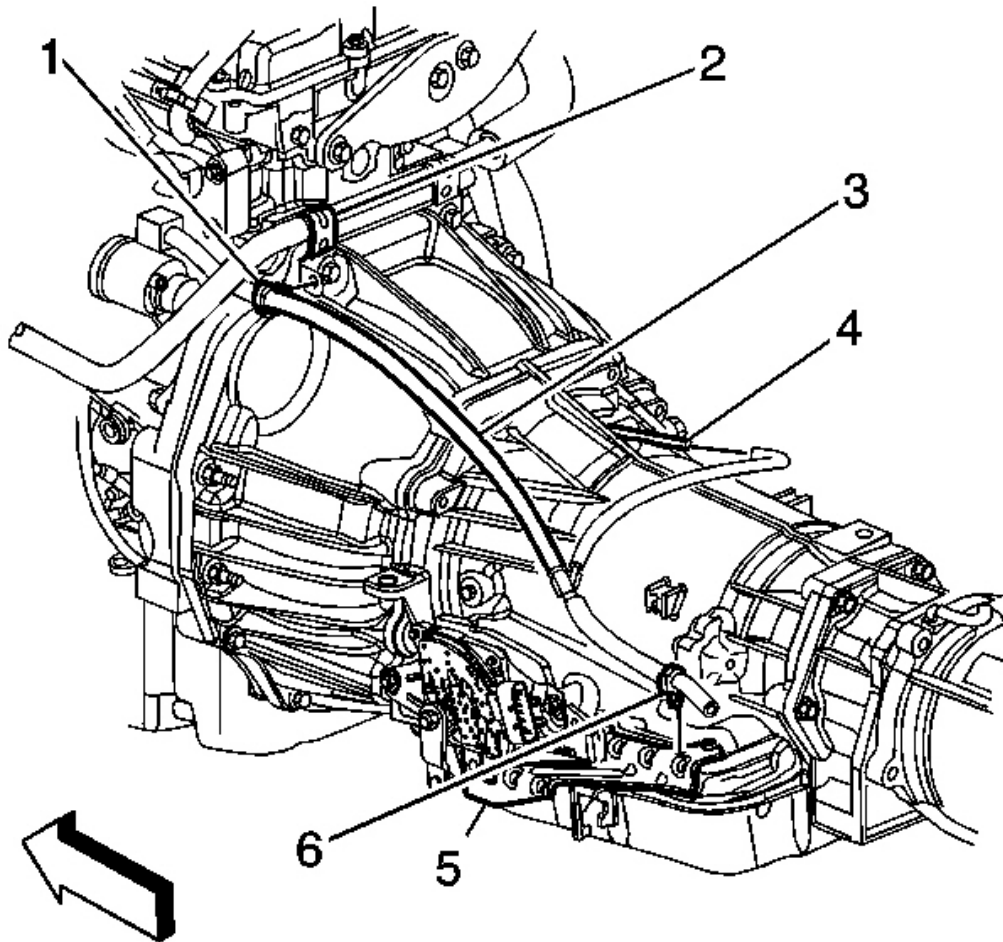

Fig. 186: View Of Transmission Vent Hose & Retainers
Courtesy of GENERAL MOTORS CORP.

16. Connect the transmission vent hose retainer (1) to the heater pipe bracket (2).

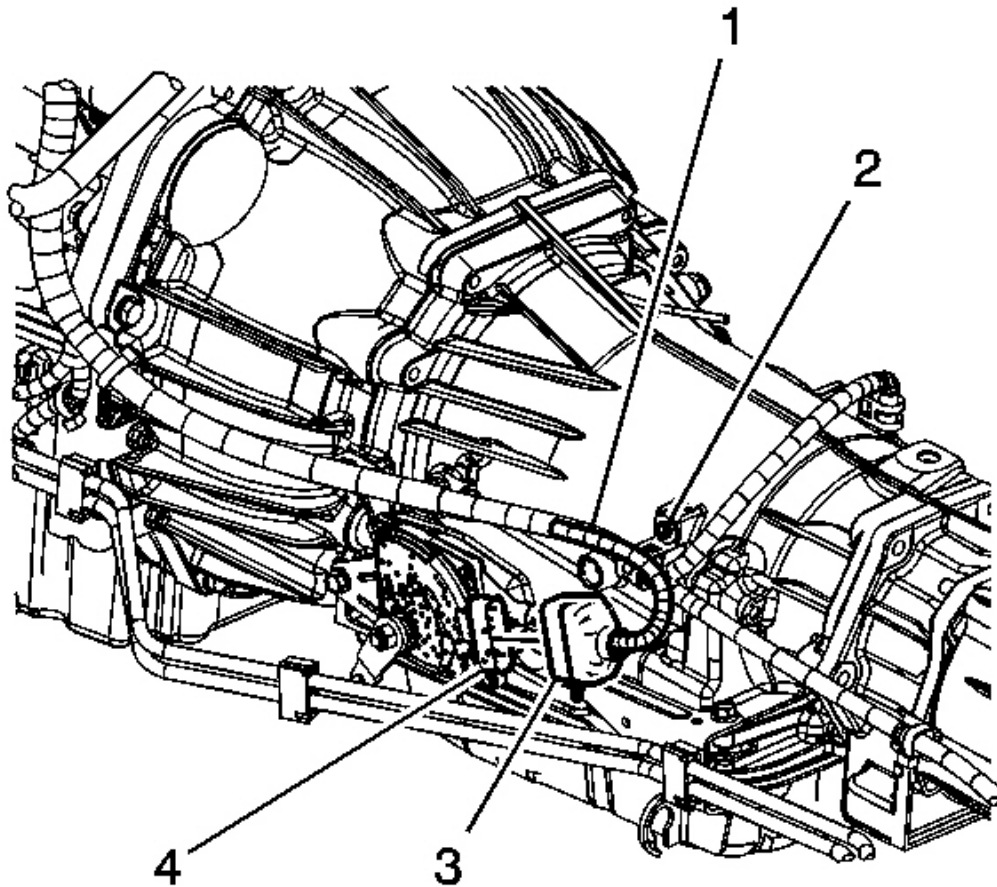

Fig. 187: View Of park/neutral back up switch, harness, electrical connector and screw

Courtesy of GENERAL MOTORS CORP.

17. Install the screw (1) securing the engine wiring harness (2) to the left side of the transmission.

Tighten: Tighten the engine wiring harness retainer to transmission screw to 9 N.m (80 lb in).

18. Connect the park/neutral back up switch electrical connector (3).
19. Lay the engine wiring harness over the transmission.

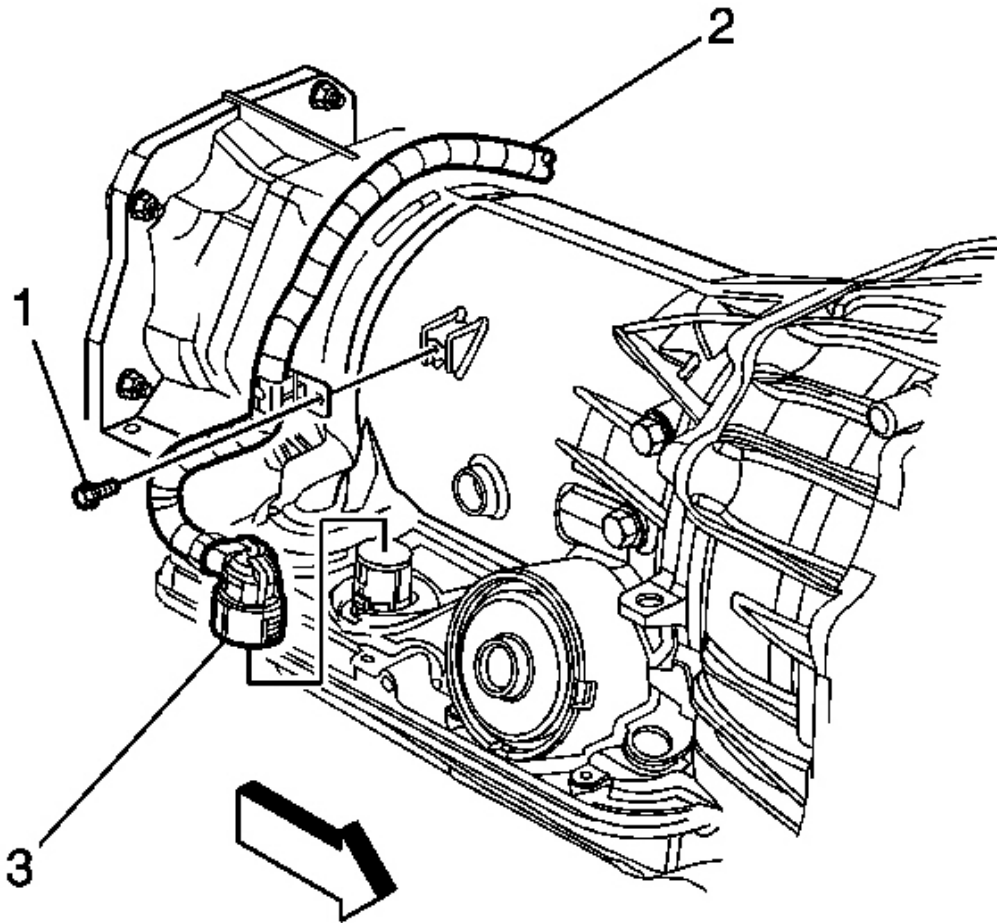

Fig. 188: View Of Screw, Engine Wiring Harness And Transmission Main Electrical Connector

Courtesy of GENERAL MOTORS CORP.

20. Connect the transmission main electrical connector (3).
21. Install the screw (1) securing the engine wiring harness (2) to the right side of the transmission.

Tighten: Tighten the engine wiring harness retainer to transmission screw to 9 N.m (80 lb in).

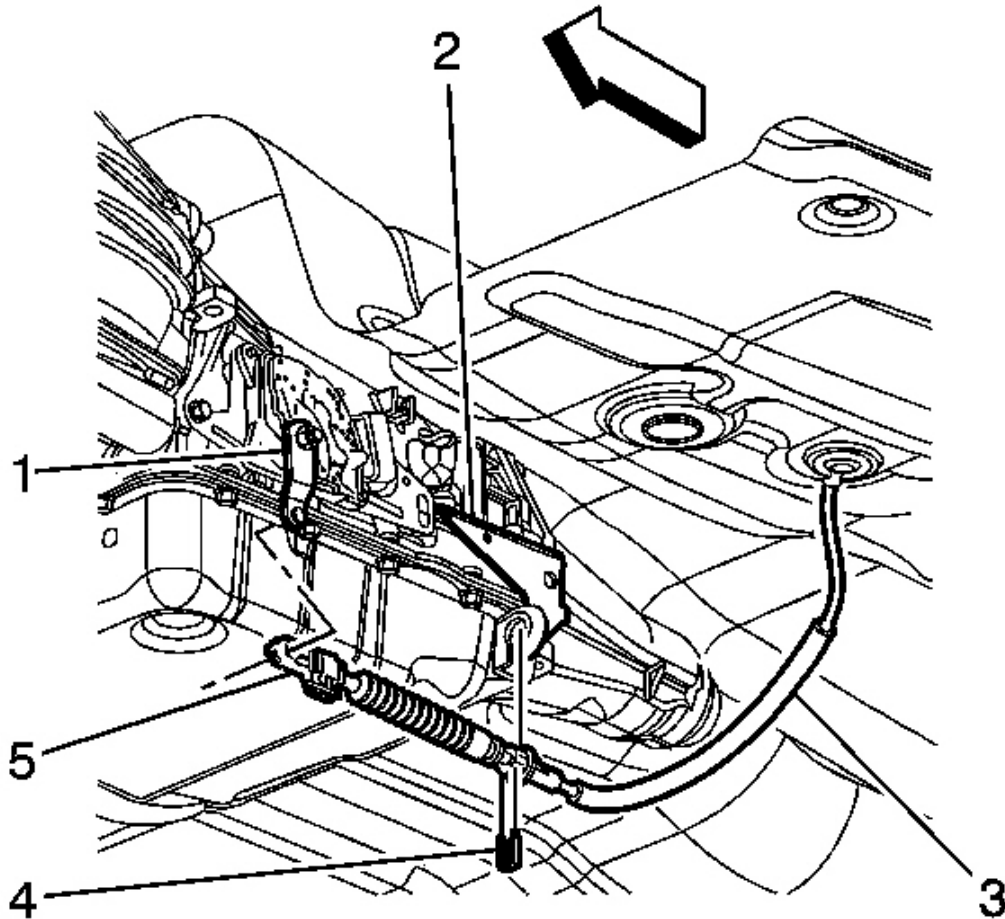

Fig. 189: View Of Range Selector Cable & Components
Courtesy of GENERAL MOTORS CORP.

22. Install the range selector cable (3) to the bracket (2).
23. Install the retainer (4) to the range selector cable (3).
24. Adjust the automatic transmission range selector cable. Refer to **Range Selector Lever Cable Adjustment**.
25. Install the transfer case assembly. Refer to **Transfer Case Assembly Replacement** .
26. Install the engine protection shield. Refer to **Oil Pan Skid Plate Replacement** .
27. Install the filler tube. Refer to **Transmission Fluid Filler Tube and Seal Replacement**.

28. Fill the transmission fluid if necessary. Refer to **Automatic Transmission Fluid and Filter Replacement**.
29. Lower the vehicle.

Transmission Final Test and Inspection

Complete the following procedure after the transmission is installed in the vehicle:

1. With the ignition OFF or disconnected, crank the engine several times. Listen for any unusual noises or evidence that any parts are binding.
2. Place transmission in neutral, start the engine and listen for any unusual noises or evidence that any parts are binding.
3. While the engine continues to idle raise and support the vehicle. Refer to **Lifting and Jacking the Vehicle**.
4. Perform a final inspection for the proper fluid level. Refer to **Transmission Fluid Check**.
5. Lower the vehicle.

IMPORTANT: It is recommended that transmission adaptive pressure (TAP) information be reset.

Resetting the TAP values using a scan tool will erase all learned values in all cells. As a result, The ECM, PCM or TCM will need to relearn TAP values. Transmission performance may be affected as new TAP values are learned.

6. Reset the TAP values. Refer to **Transmission Adaptive Functions**.
7. Road test the vehicle.

REPAIR INSTRUCTIONS - OFF VEHICLE

HOLDING FIXTURE INSTALLATION

Tools Required

J 8763-B Holding Fixture and Base. See **Special Tools**.

Installation Procedure

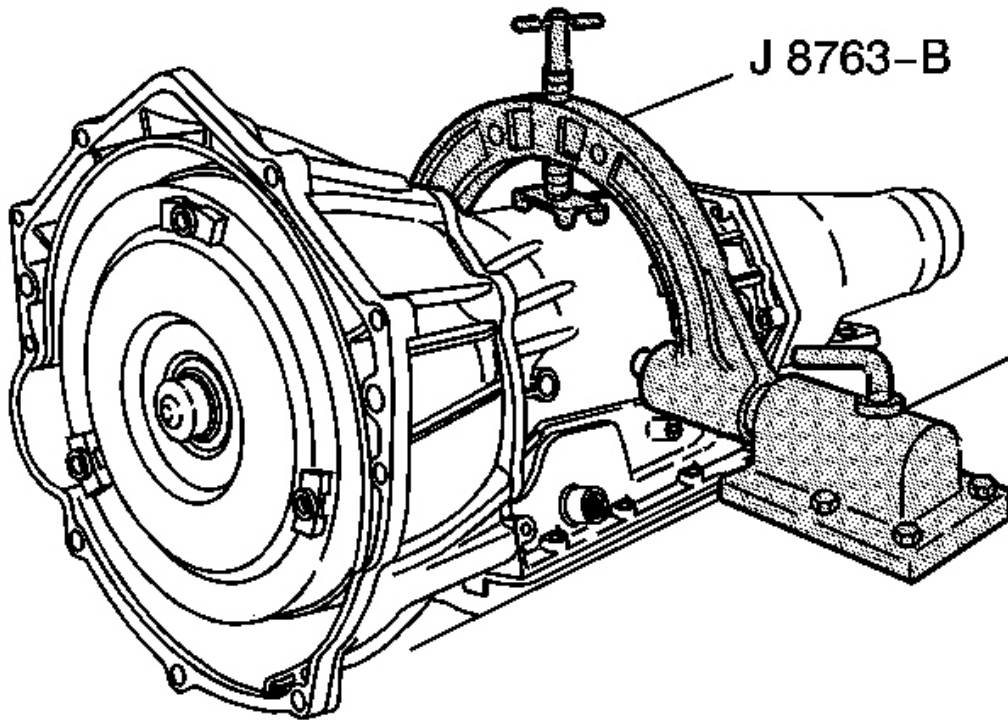

Fig. 190: View Of J 8763-B

Courtesy of GENERAL MOTORS CORP.

1. Install the **J 8763-B** onto the transmission. See **Special Tools**.
2. Install the **J 8763-B** into the base. See **Special Tools**.

TORQUE CONVERTER ASSEMBLY REMOVAL

CAUTION: The torque converter weighs approximately 65 lbs. Personal injury may result if you lift the torque converter improperly.

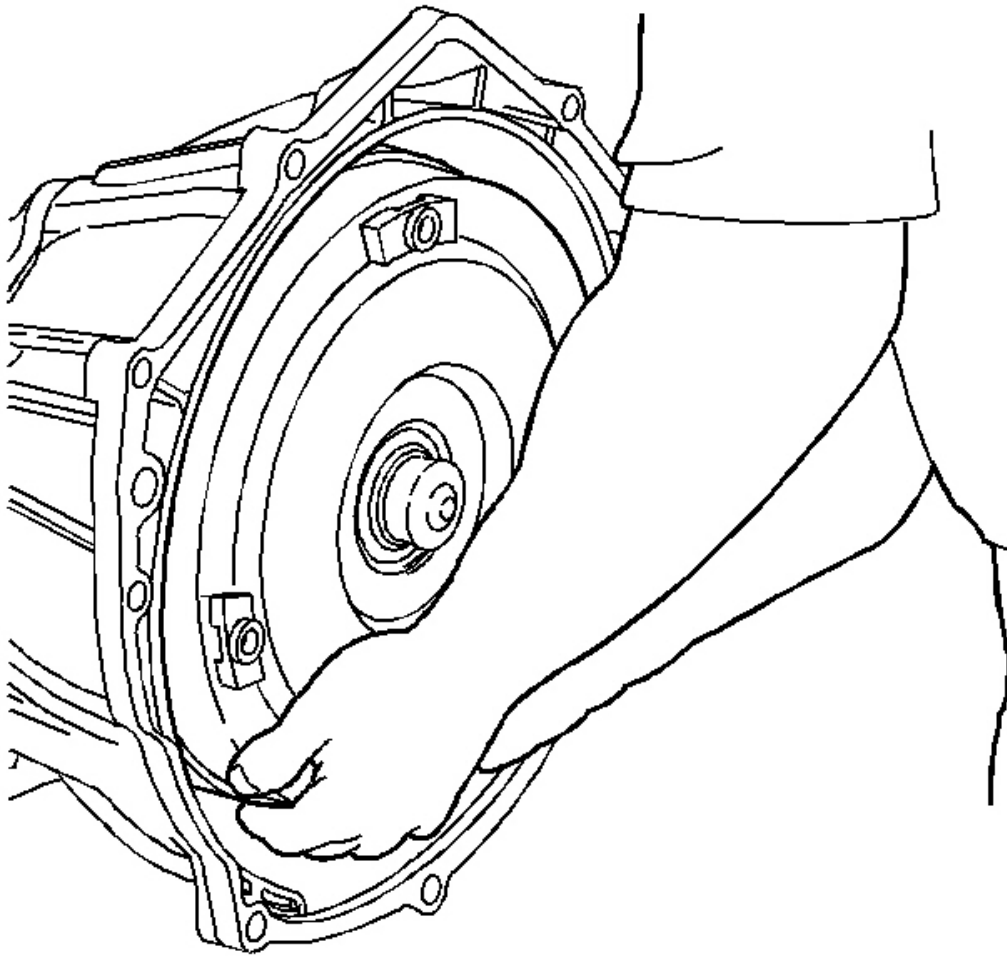

Fig. 191: Removing Torque Converter
Courtesy of GENERAL MOTORS CORP.

Remove the torque converter.

DRAIN OIL

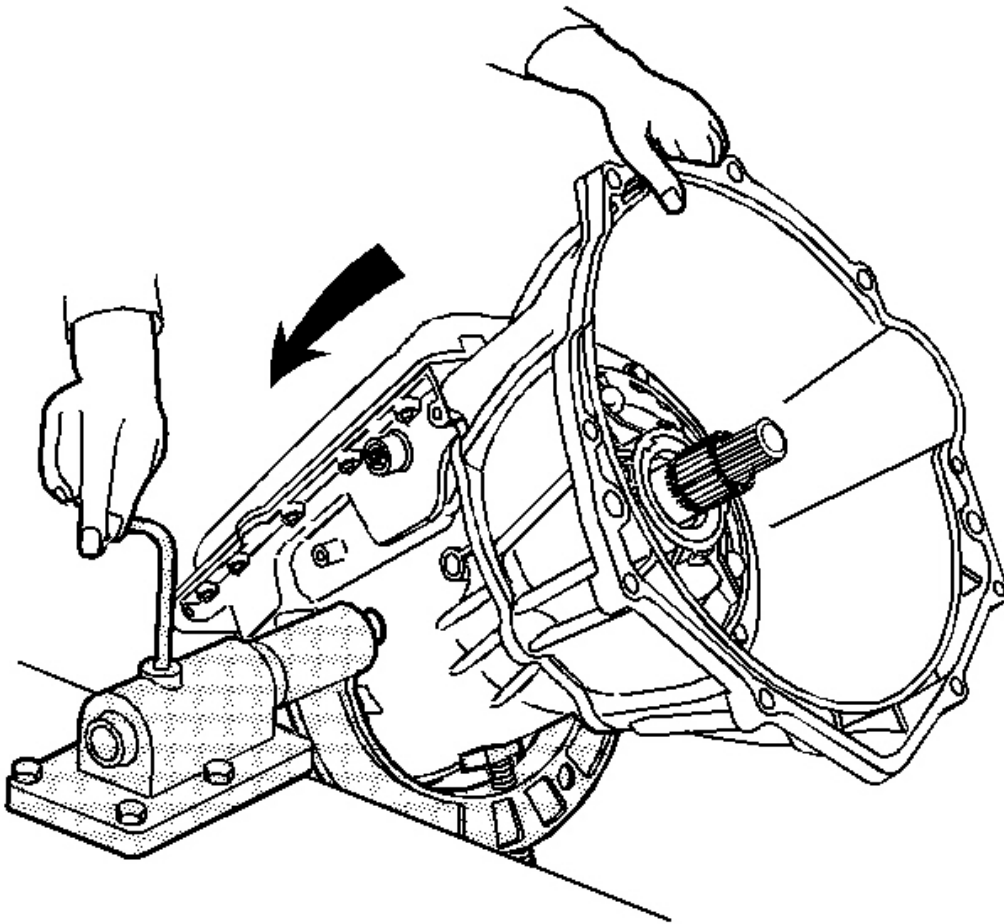

Fig. 192: Draining Transmission Oil
Courtesy of GENERAL MOTORS CORP.

Rotate the transmission so that the converter housing is up. Allow the transmission fluid to drain from the case extension.

CONVERTER HOUSING REMOVAL

Tools Required

J 41510 T-50 Plus Bit. See **Special Tools**.

Removal Procedure

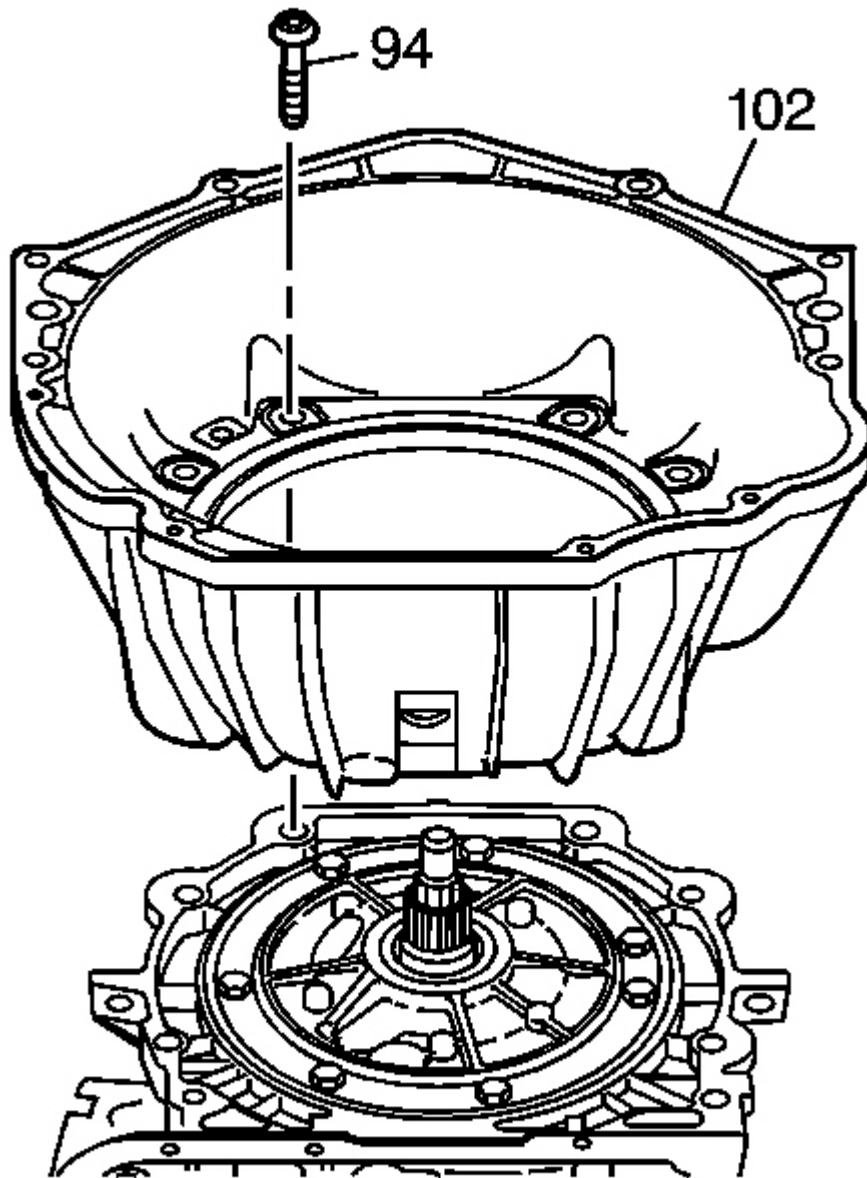

Fig. 193: View Of Converter Housing Bolts
Courtesy of GENERAL MOTORS CORP.

1. Remove the converter housing bolts (94). Use the **J 41510** . See **Special Tools**.
2. Remove the converter housing (102).

2-4 SERVO COVER AND ASSEMBLY REMOVAL

Tools Required

J 29714-A Servo Cover Depressor. See **Special Tools**.

Removal Procedure

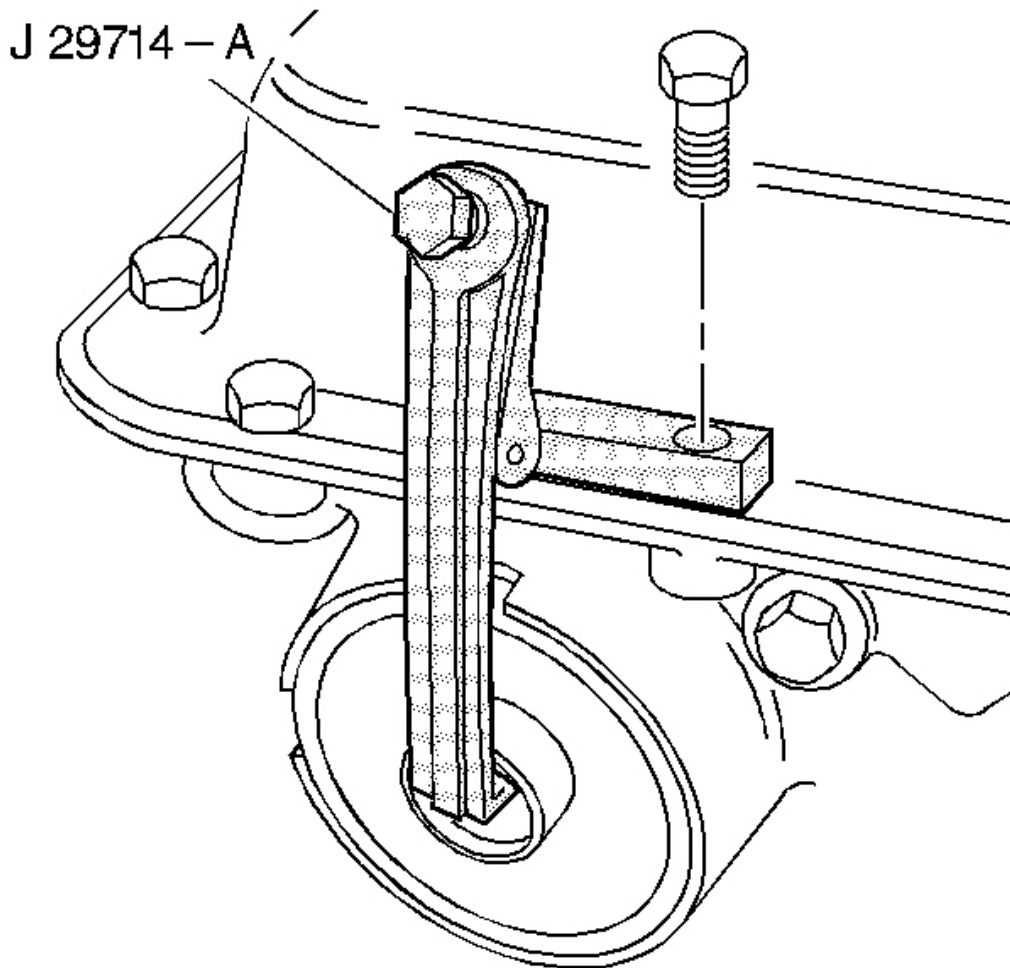

Fig. 194: Installing J 29714-A
Courtesy of GENERAL MOTORS CORP.

1. Install the **J 29714-A** . See **Special Tools**.

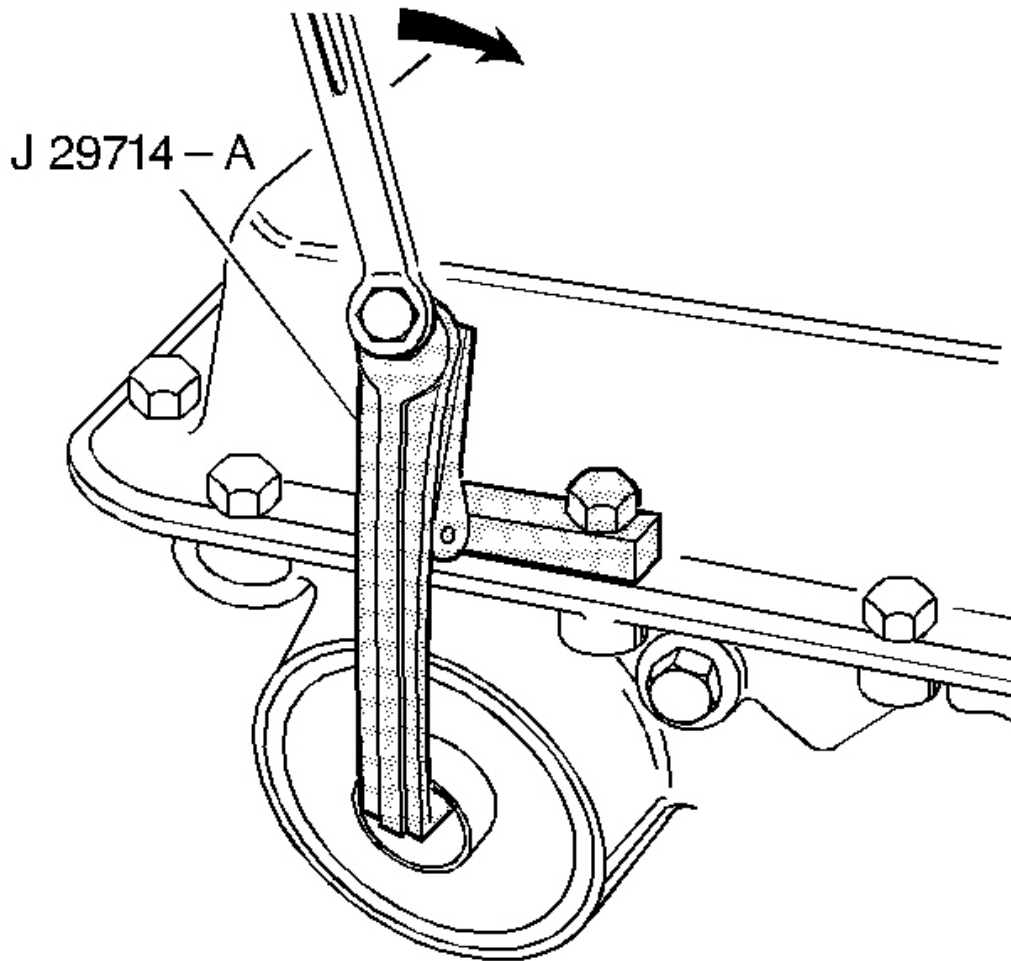

Fig. 195: Compressing Servo Cover With J 29714-A
Courtesy of GENERAL MOTORS CORP.

IMPORTANT: If cover does not move inwards with tool, use a block of wood or suitable material and lightly tap on cover using a hammer to free up cover in bore.

2. Tighten the **J 29714-A** bolt to compress the servo cover. See **Special Tools**.

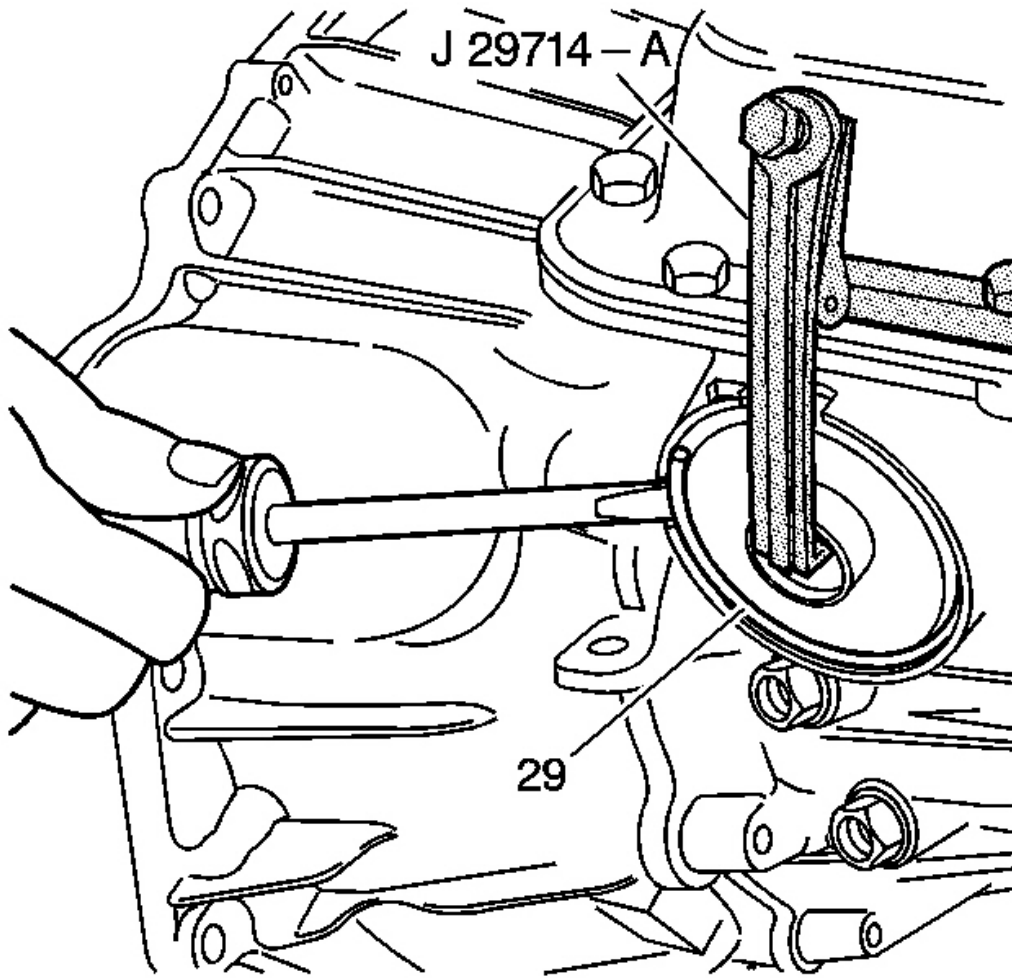

Fig. 196: Locating Servo Cover Retaining Ring
Courtesy of GENERAL MOTORS CORP.

3. Remove the servo cover retaining ring (29) and the J 29714-A . See **Special Tools**.

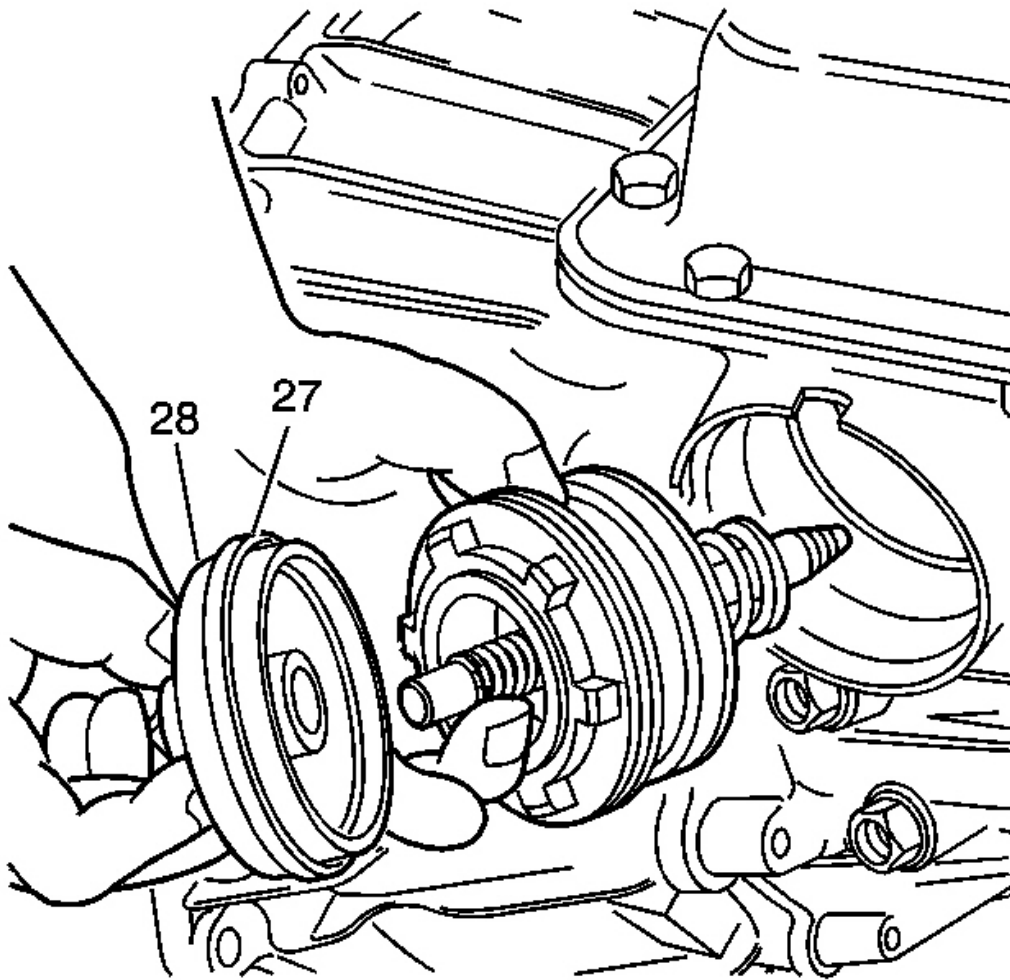

Fig. 197: View Of 2-4 Servo Assembly
Courtesy of GENERAL MOTORS CORP.

4. Remove the servo cover (28) and O-ring seal (27). If the servo cover seems to be hung up on the seal, cut and remove the O-ring seal before removing the cover.
5. Remove the 2-4 servo assembly.

2-4 SERVO PIN LENGTH CHECK

Tools Required

J 33037 2-4 Intermediate Band Apply Pin Gage. See **Special Tools**.

Procedure

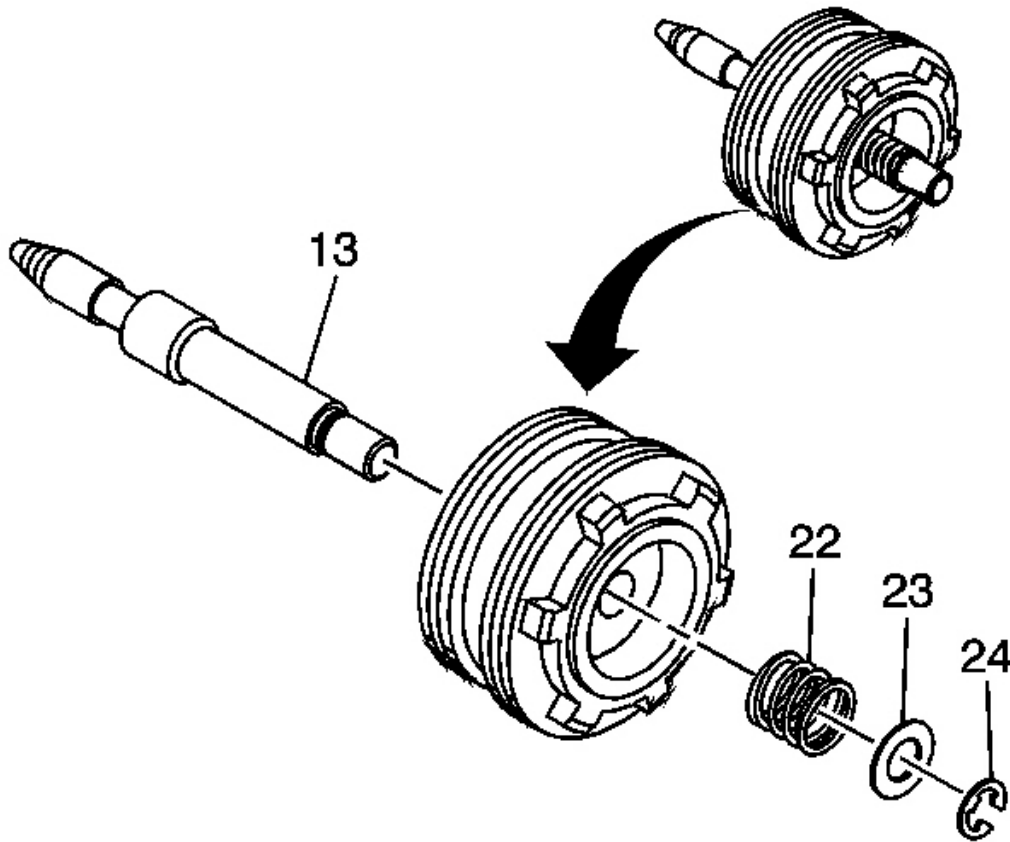

Fig. 198: 2-4 Servo Assembly
Courtesy of GENERAL MOTORS CORP.

1. Disassemble the 2-4 servo assembly. If necessary, refer to 2-4 Servo Disassemble.

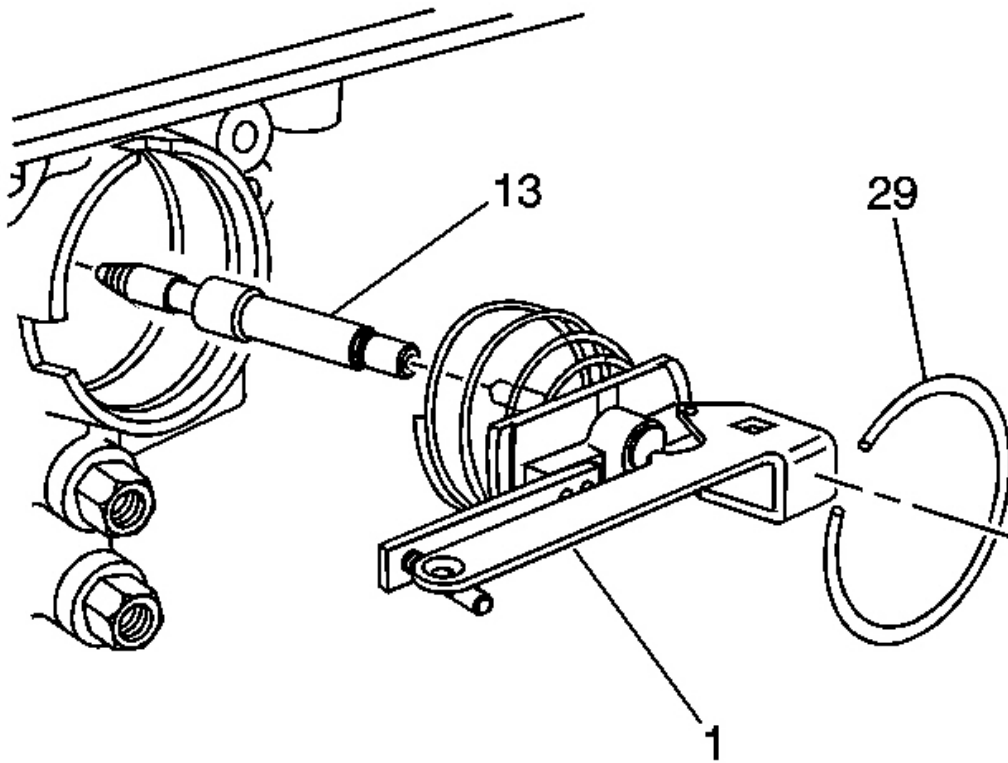

Fig. 199: Locating Servo Cover Retaining Ring
Courtesy of GENERAL MOTORS CORP.

2. Install the band apply pin (13) and the **J 33037** (1). See **Special Tools**.
3. Install the servo cover retaining ring (29) to secure the tool.

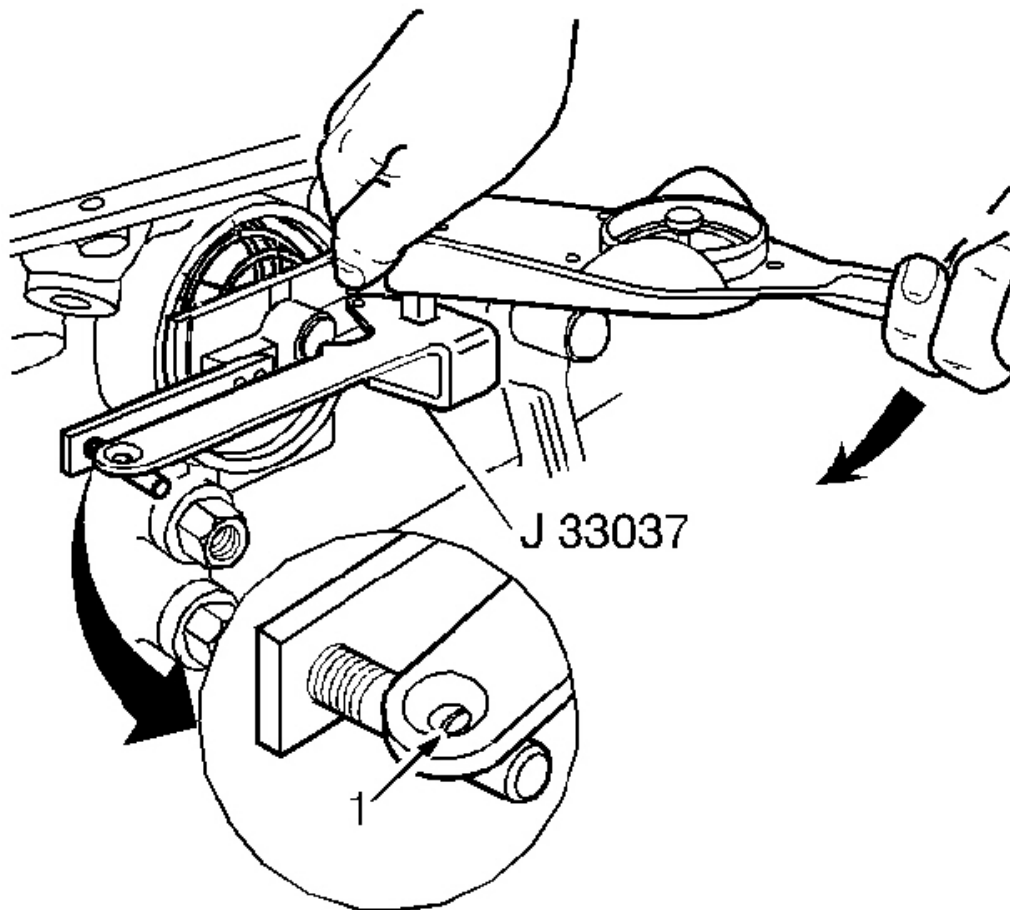

Fig. 200: Identifying Gage Slot
Courtesy of GENERAL MOTORS CORP.

4. Apply 11 N.m (98 lb in) torque. If the white line appears in the gage slot (1), the pin length is correct.
5. If a new pin is needed, refer to **2-4 Servo Pin Selection** in order to determine correct pin length.

TRANSMISSION FLUID PAN AND FILTER ASSEMBLY REMOVAL

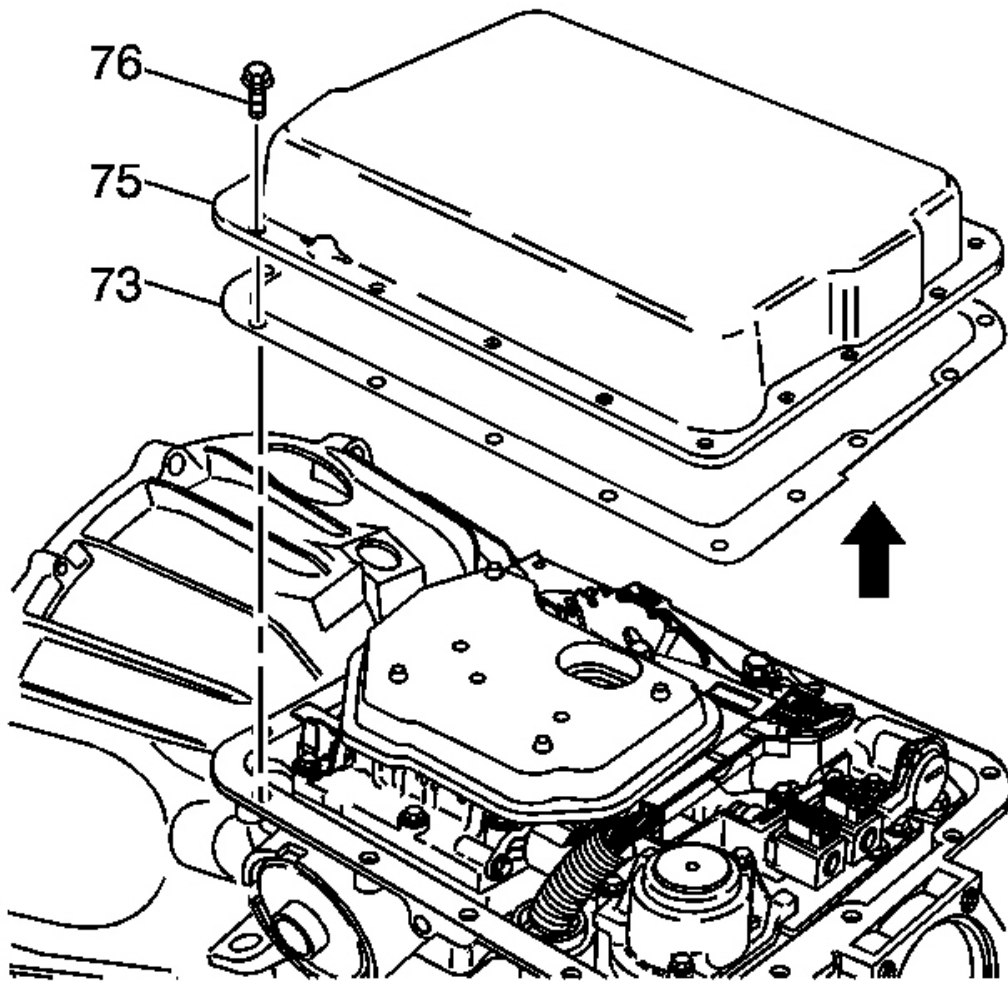

Fig. 201: View Of Transmission Oil Pan & Gasket
Courtesy of GENERAL MOTORS CORP.

1. Remove the transmission oil pan screws (76).
2. Remove the transmission oil pan (75) and the transmission oil pan gasket (73).

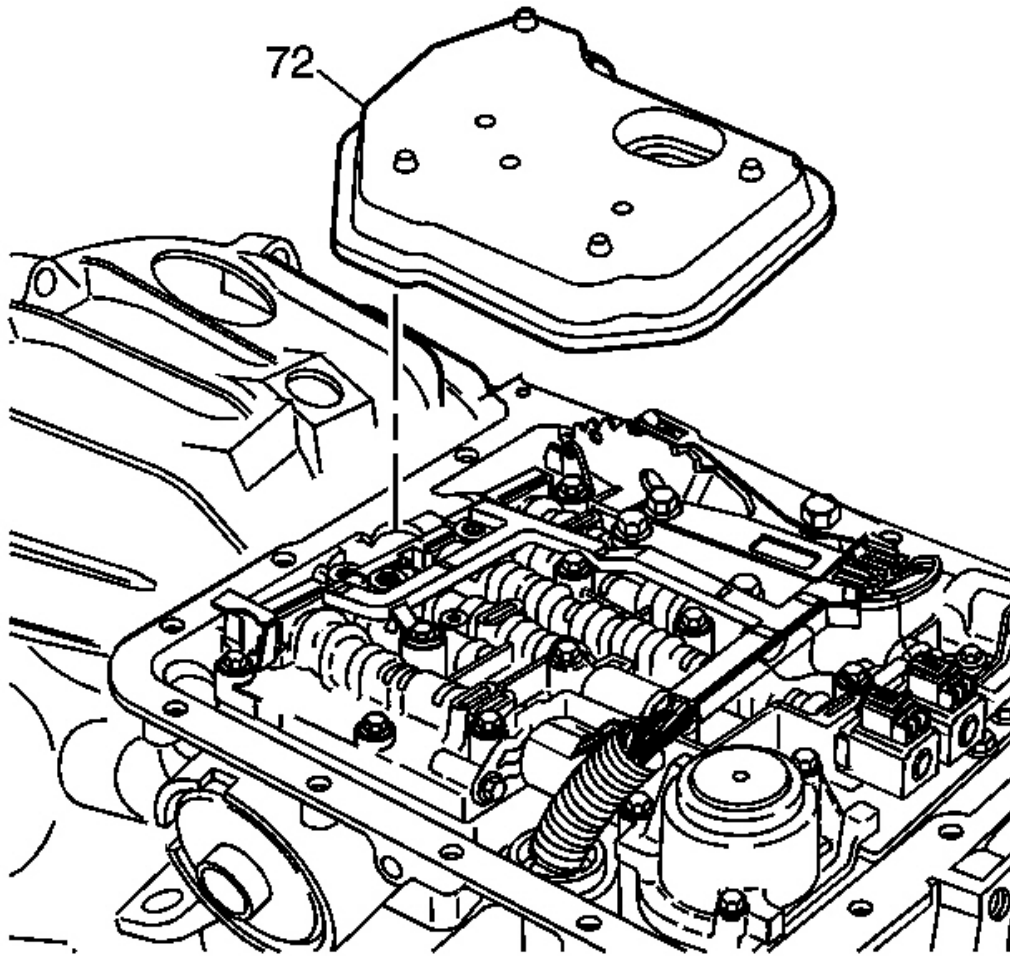

Fig. 202: Identifying Transmission Oil Filter Assembly
Courtesy of GENERAL MOTORS CORP.

3. Remove the transmission oil filter assembly (72).
4. The filter may help in diagnosis. Cut away the top portion of the plastic filter housing and remove. Inspect the filter for the presence of the following items which may indicate wear or corrosion:
 - Clutch material
 - Bronze slivers indicating bushing wear
 - Steel particles

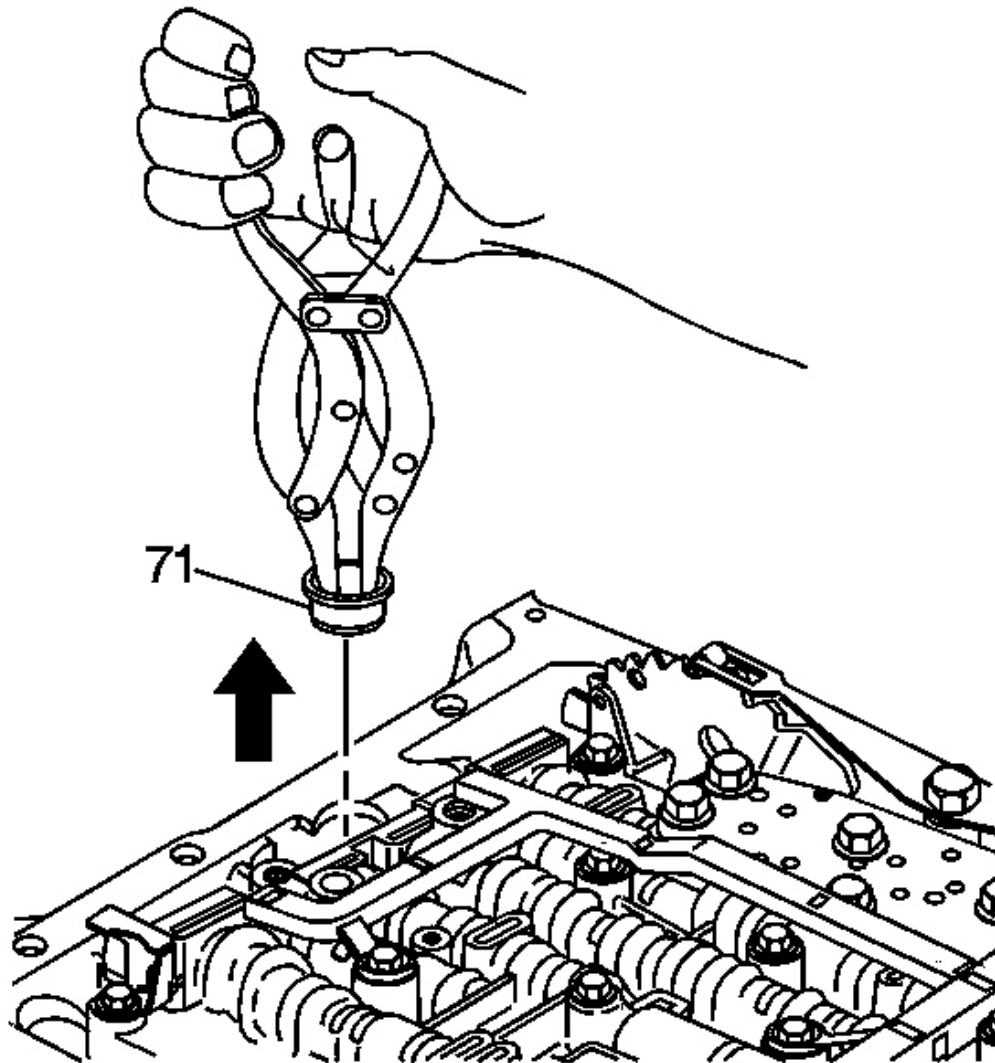

Fig. 203: Removing Oil Filter Seal
Courtesy of GENERAL MOTORS CORP.

5. Remove the oil filter seal (71).

CONTROL VALVE BODY AND WIRING HARNESS REMOVAL

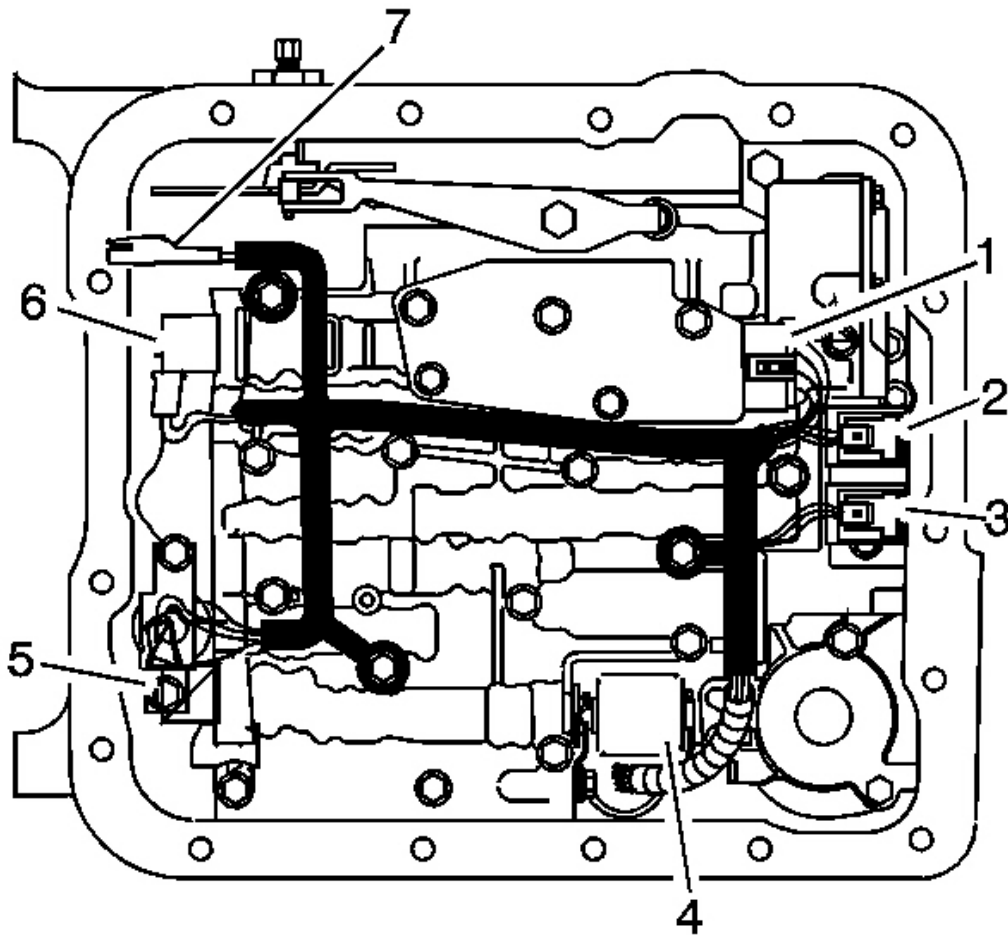

Fig. 204: Valve Body & Wiring Harness
Courtesy of GENERAL MOTORS CORP.

1. Remove all electrical connectors (1-6) from the electrical components.

For transmissions with input speed sensors, disconnect the electrical connector (7).

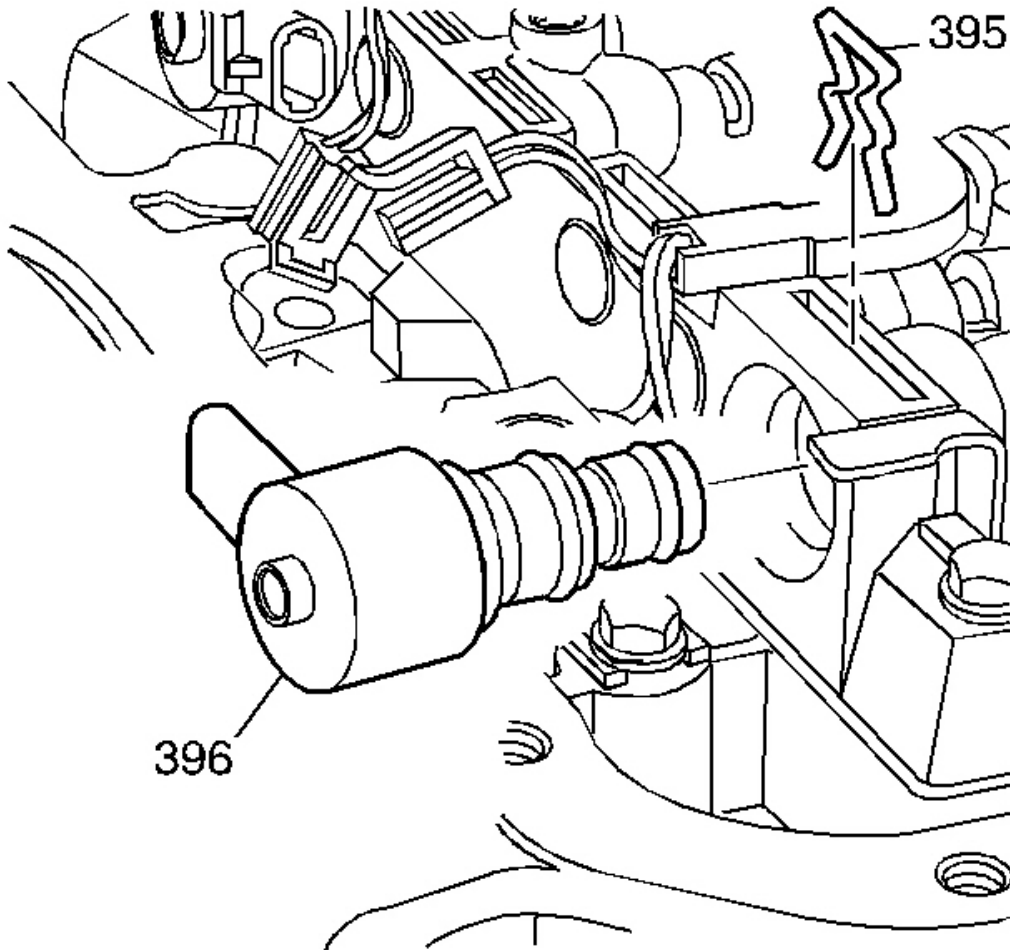

Fig. 205: Removing TCC/PWM Solenoid & Clip
Courtesy of GENERAL MOTORS CORP.

2. Remove the torque converter clutch pulse width modulation (TCC/PWM) retainer clip (395).
3. Remove the TCC/PWM solenoid (396).

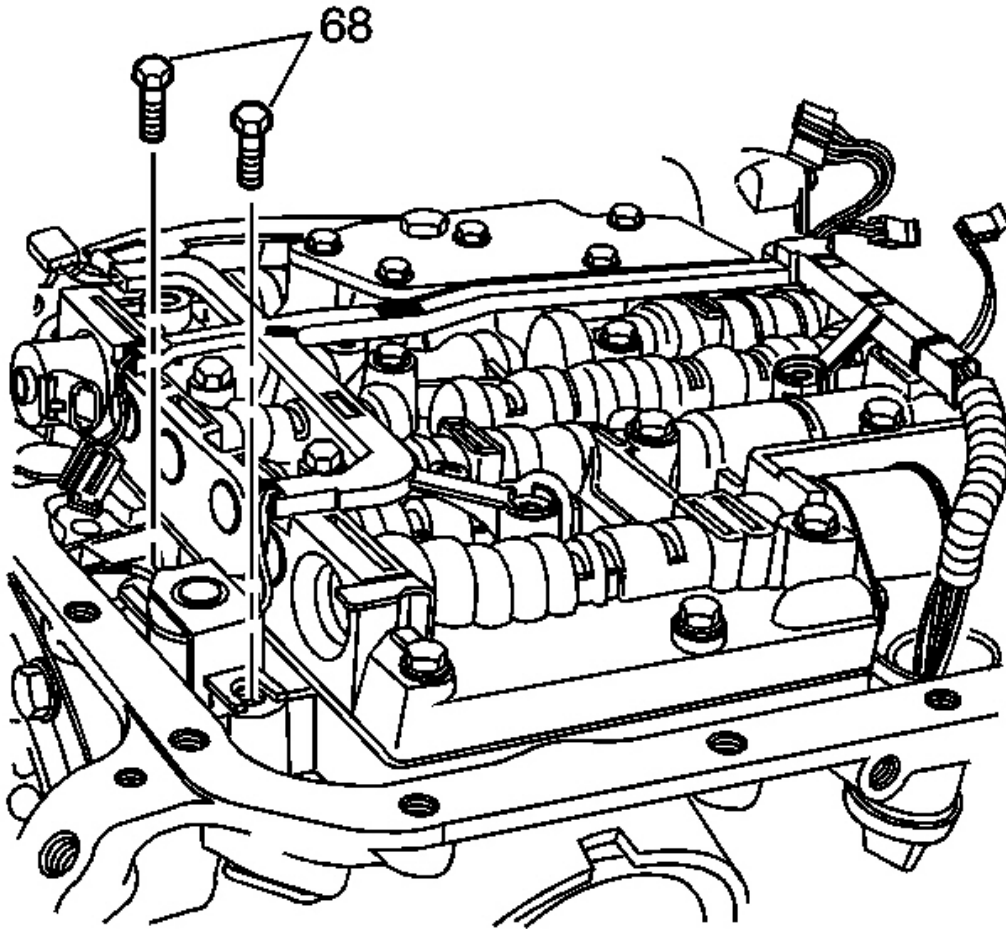

Fig. 206: View Of TCC Solenoid Bolts
Courtesy of GENERAL MOTORS CORP.

4. Remove the TCC solenoid bolts (68).

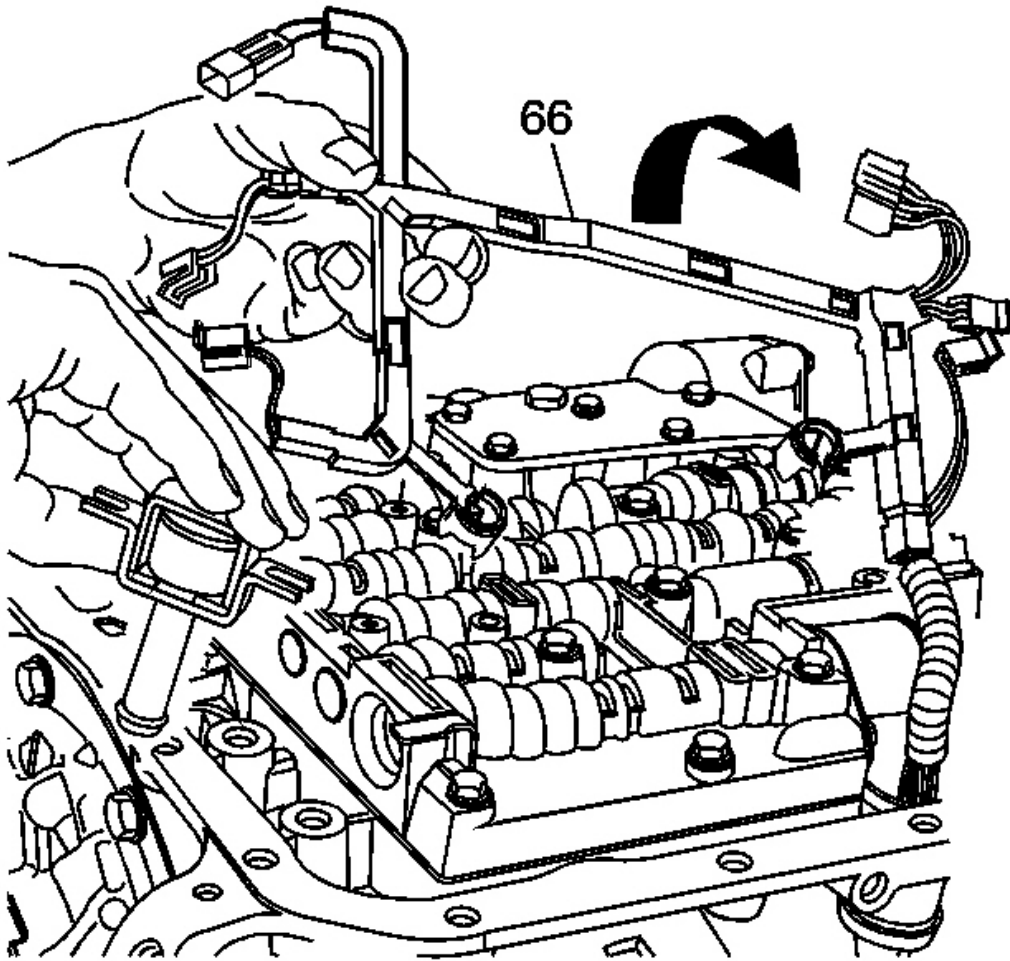

Fig. 207: View TCC Solenoid Wiring Harness
Courtesy of GENERAL MOTORS CORP.

5. Remove the TCC solenoid and wiring harness (66). Turn the wiring harness over so that it hangs over the side of the transmission.

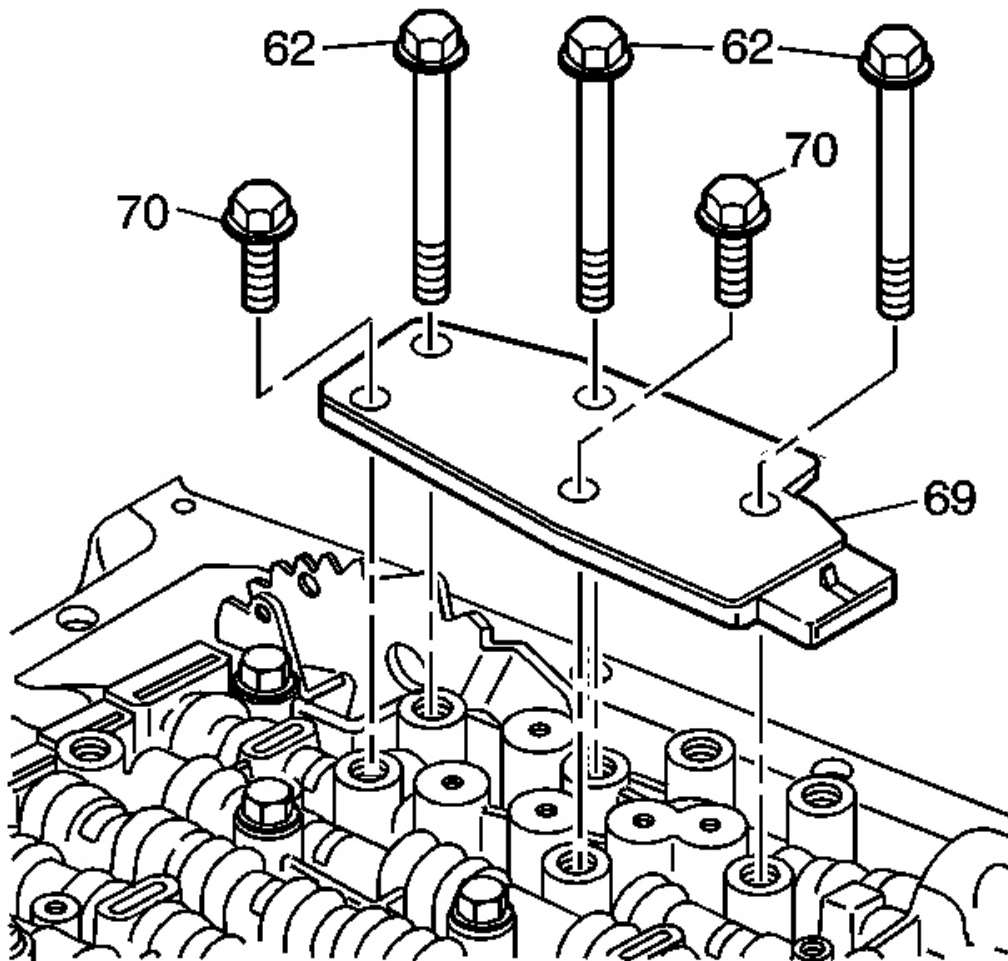

Fig. 208: TFP Manual Valve Position Switch Retaining Bolts
Courtesy of GENERAL MOTORS CORP.

6. Remove the transmission fluid pressure (TFP) manual valve position switch assembly bolts (62, 70).
7. Remove the TFP manual valve position switch (69).

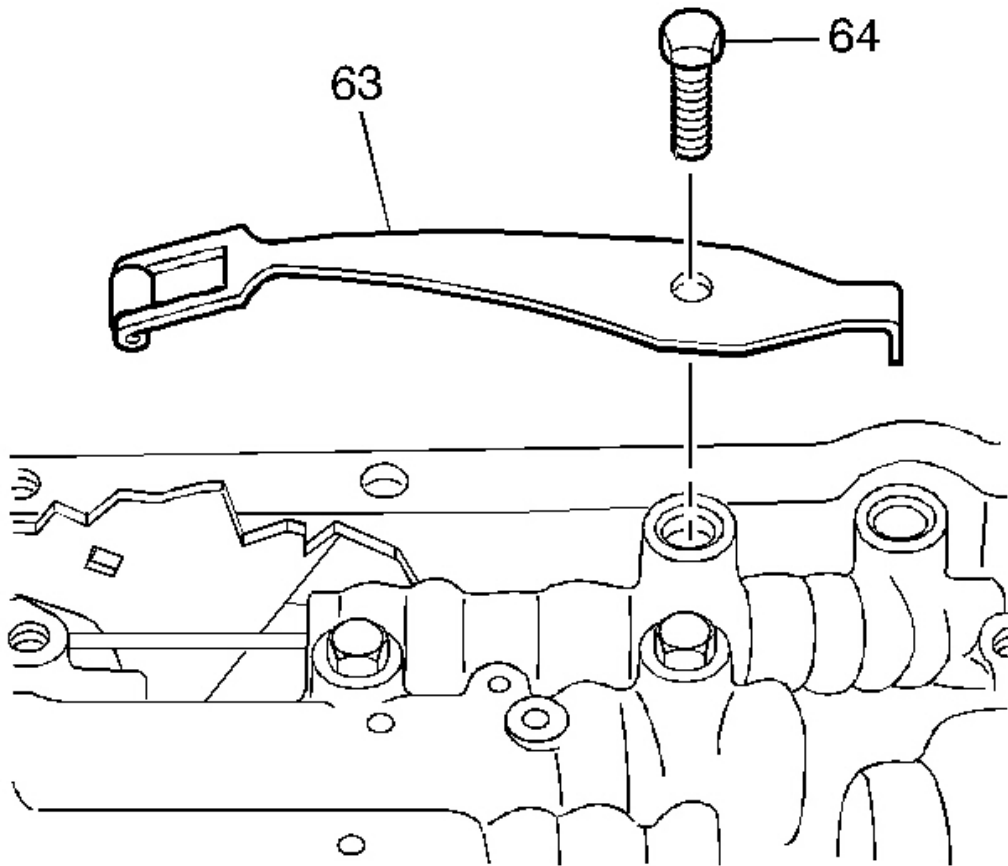

Fig. 209: View Of Manual Detent Spring Assembly
Courtesy of GENERAL MOTORS CORP.

8. Remove the manual detent spring bolt (64).
9. Remove the manual detent spring assembly (63).

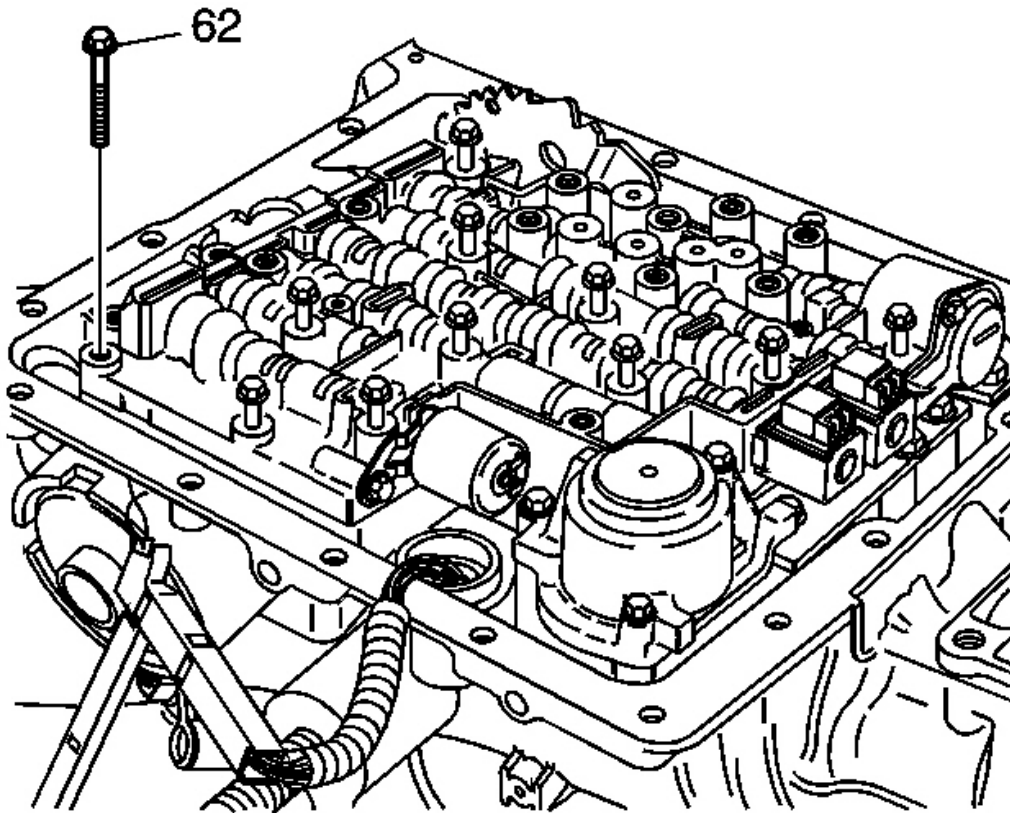

Fig. 210: View Of Valve Body Bolts
Courtesy of GENERAL MOTORS CORP.

10. Remove all valve body bolts (62).

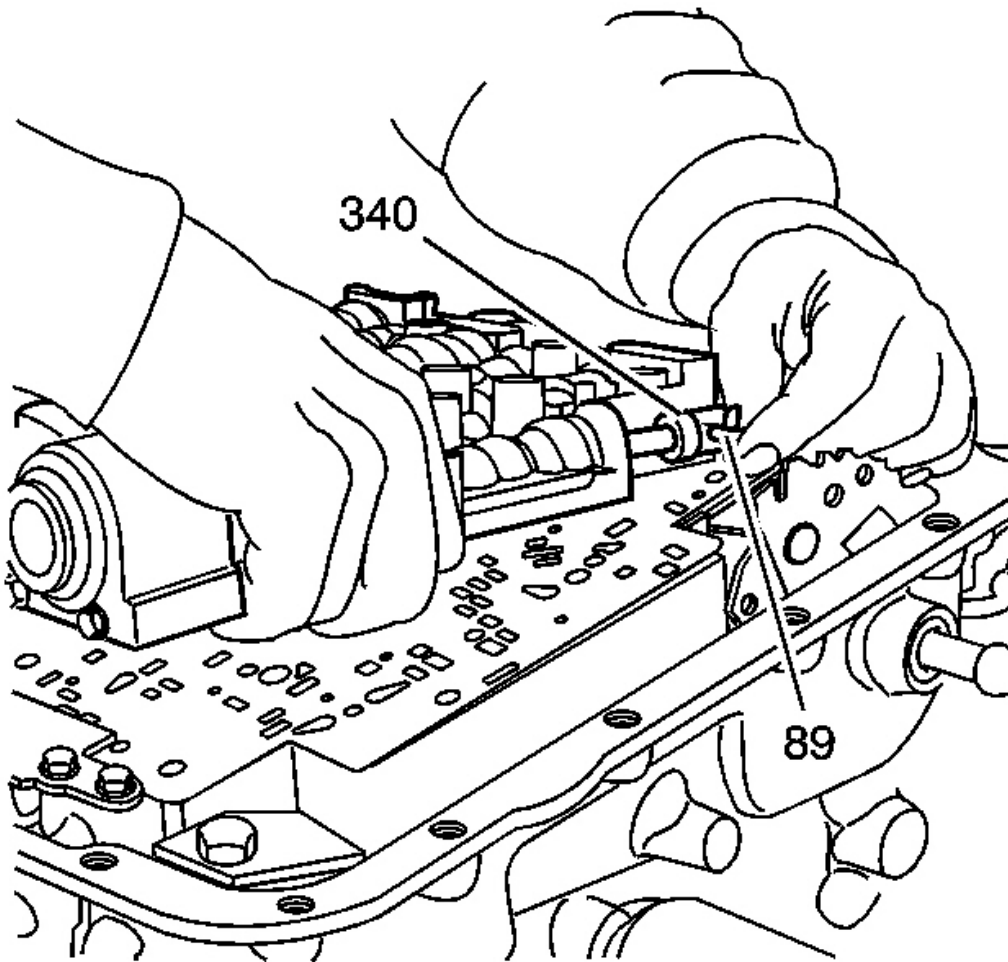

Fig. 211: Disconnecting Manual Valve Link
Courtesy of GENERAL MOTORS CORP.

11. Lift the valve body carefully so that the checkballs remain on the spacer plate in the correct location. While lifting the valve body, disconnect the manual valve link (89) from the manual valve (340).

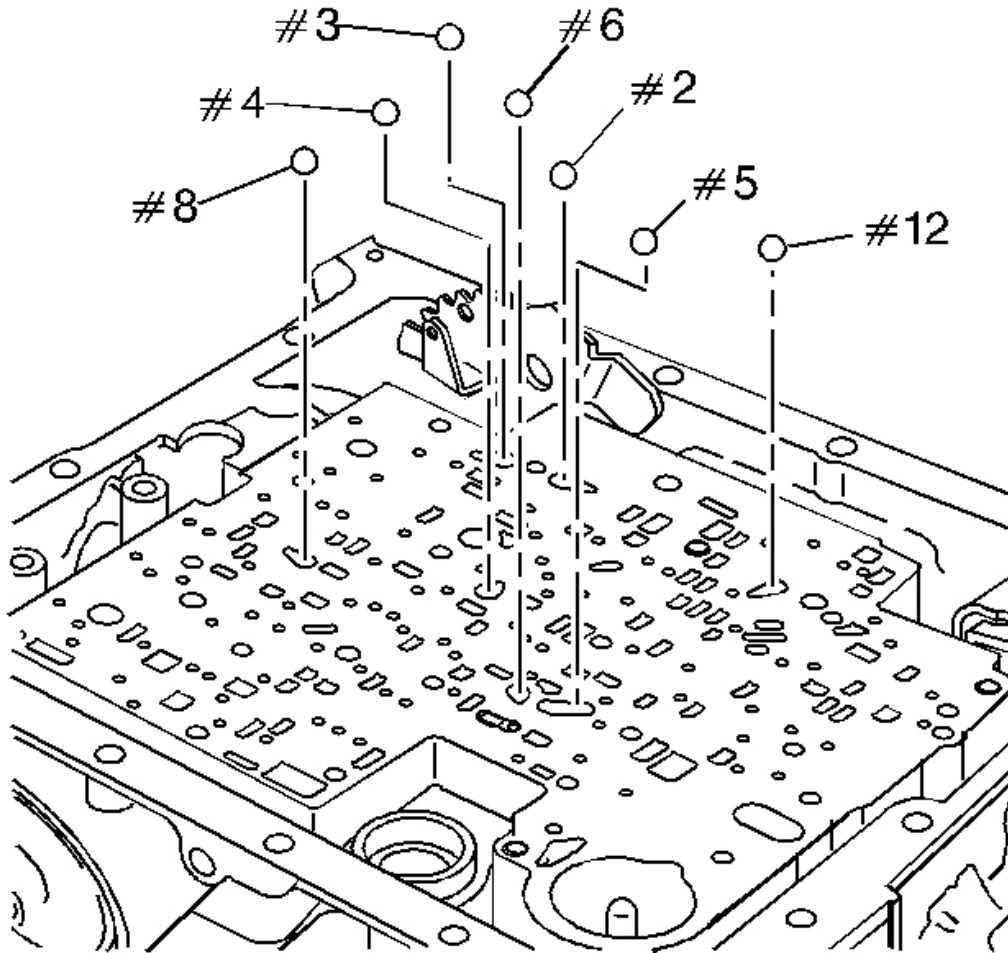

Fig. 212: Identifying Valve Body Checkballs
Courtesy of GENERAL MOTORS CORP.

NOTE: Do not use a magnet in order to remove the control valve body ball check valves. This may magnetize the control valve body ball check valves, causing metal particles to stick to them.

IMPORTANT: Some models do not use a #5 ball check valve.

12. Remove the 7 valve body ball check valves (2-6, 8 and 12).

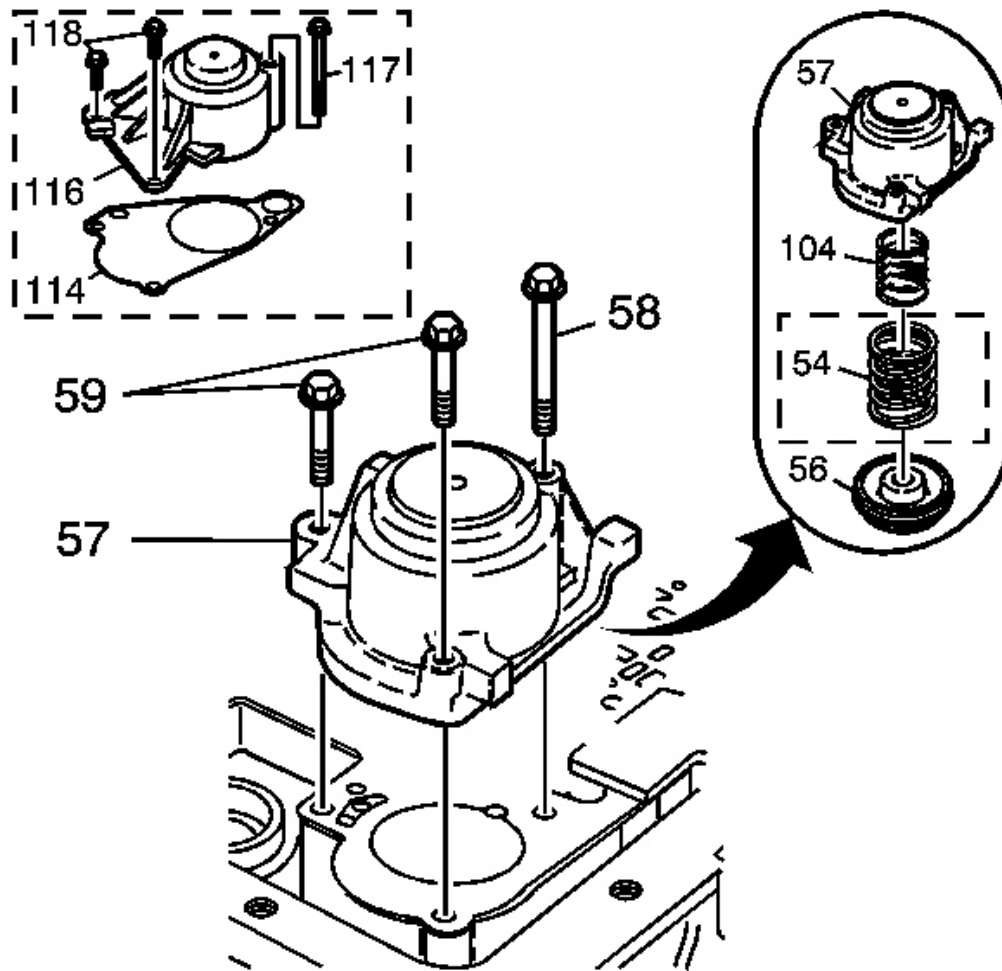

Fig. 213: View Of Body Ball Check Valves & Cover Bolts
 Courtesy of GENERAL MOTORS CORP.

13. Remove the accumulator cover bolts (58, 59 or 117, 118).
14. Remove the 1-2 accumulator cover and pin assembly (57) or 1-2 accumulator cover assembly (116) and gasket (114).

IMPORTANT: Some models do not use an outer 1-2 accumulator spring (54).

15. Disassemble the 1-2 accumulator assembly (54, 56, 57, 104).

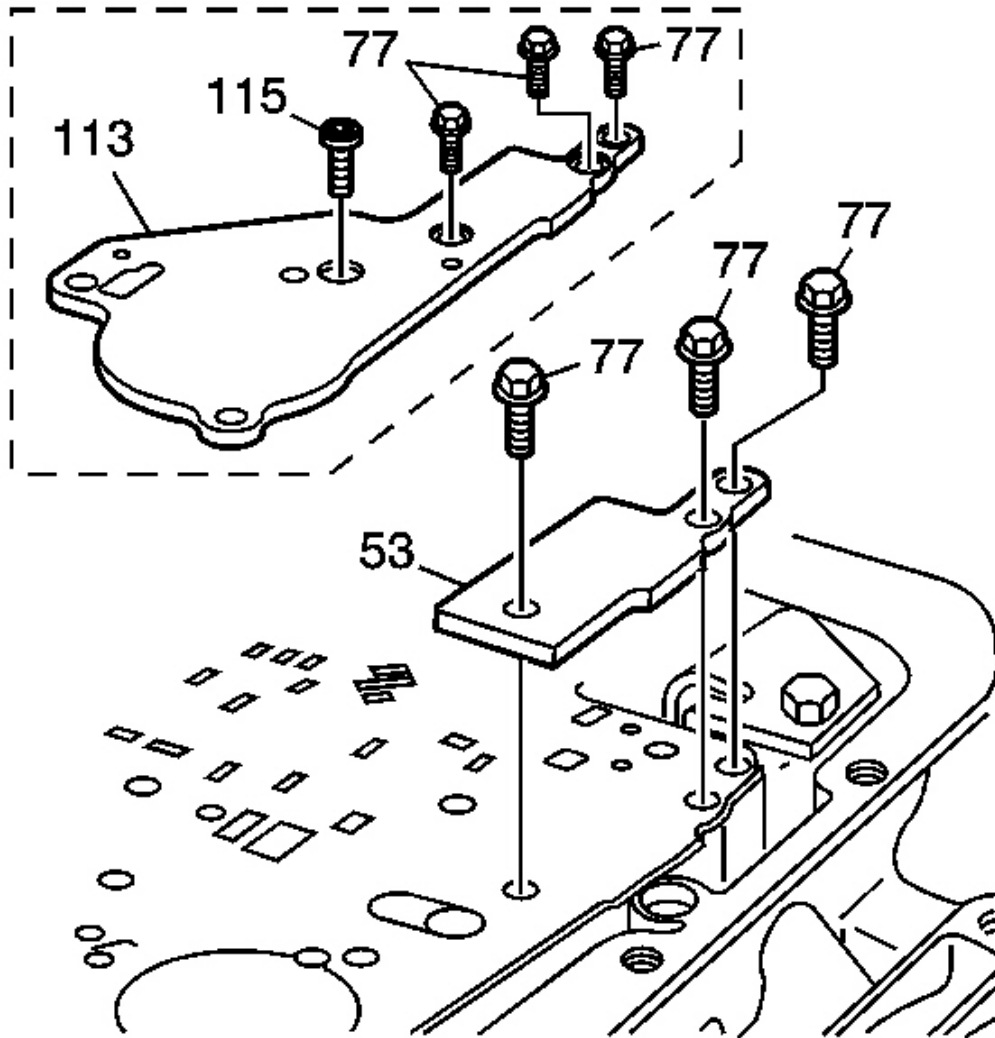

Fig. 214: View Of Spacer Plate Support Plate & Bolts
Courtesy of GENERAL MOTORS CORP.

16. Remove the spacer plate support bolts (77).
17. Remove the spacer plate support (53 or 113).

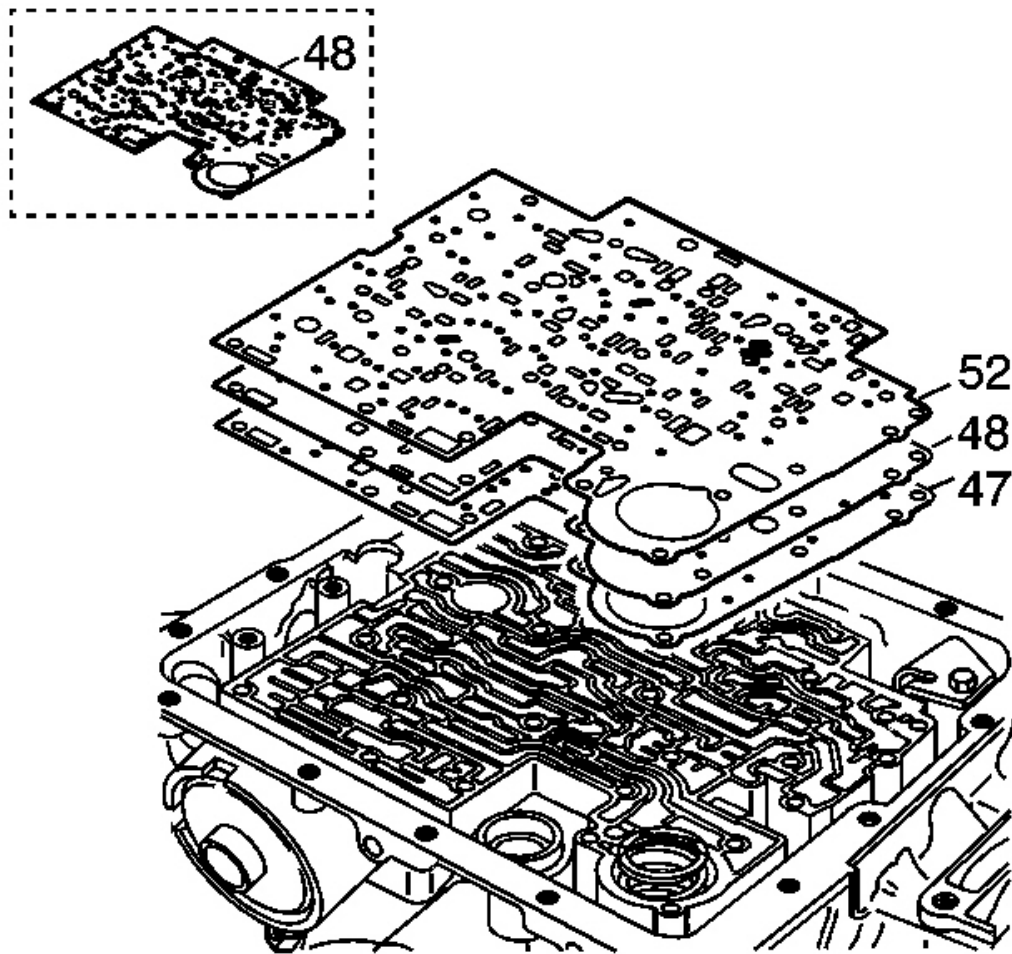

Fig. 215: Identifying Valve Body Gasket
Courtesy of GENERAL MOTORS CORP.

IMPORTANT: Some models use a bonded spacer plate (48). Do not reuse the bonded spacer plate. Replace with a NEW bonded spacer plate.

18. Remove the valve body gasket (52), the valve body spacer plate (48) and the case gasket (47).

Discard gaskets. Do not reuse.

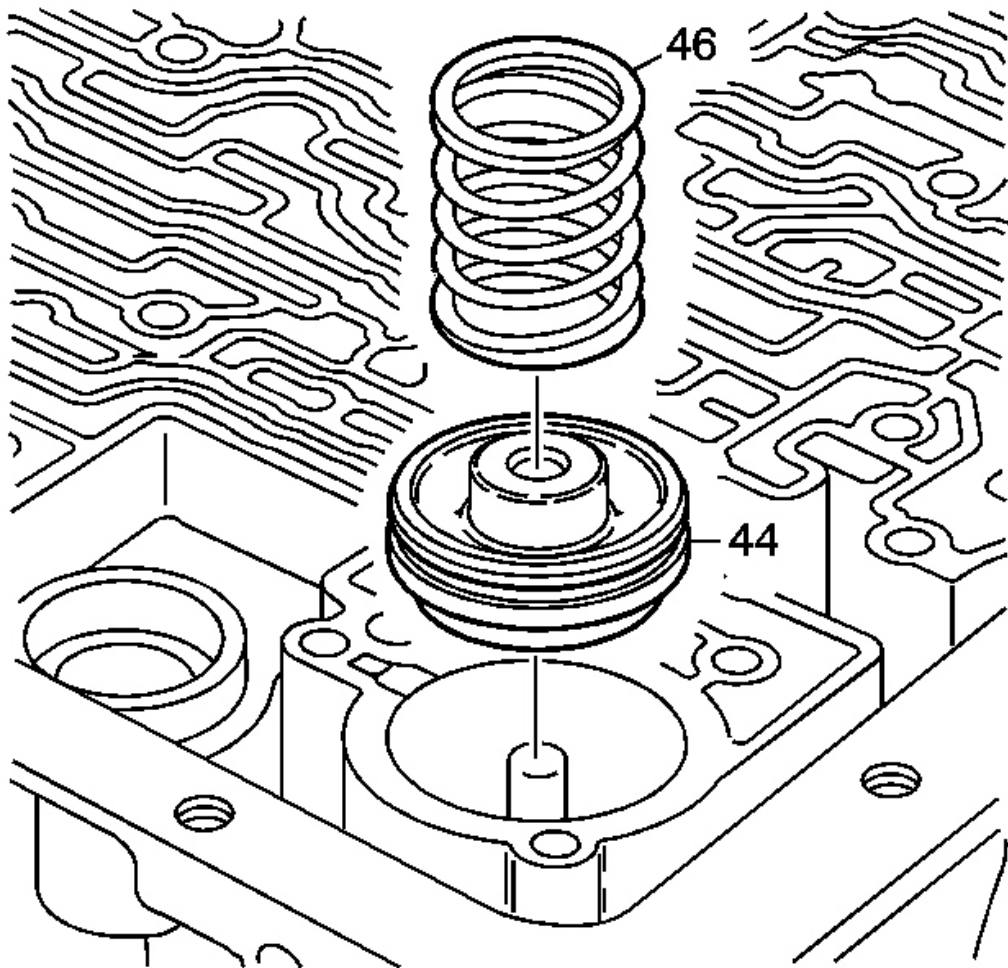

Fig. 216: View Of 3-4 Accumulator Piston & Seal Assembly
Courtesy of GENERAL MOTORS CORP.

IMPORTANT: Some models do not use a 3-4 accumulator spring (46).

19. Remove the 3-4 accumulator spring (46) and the 3-4 accumulator piston (44).

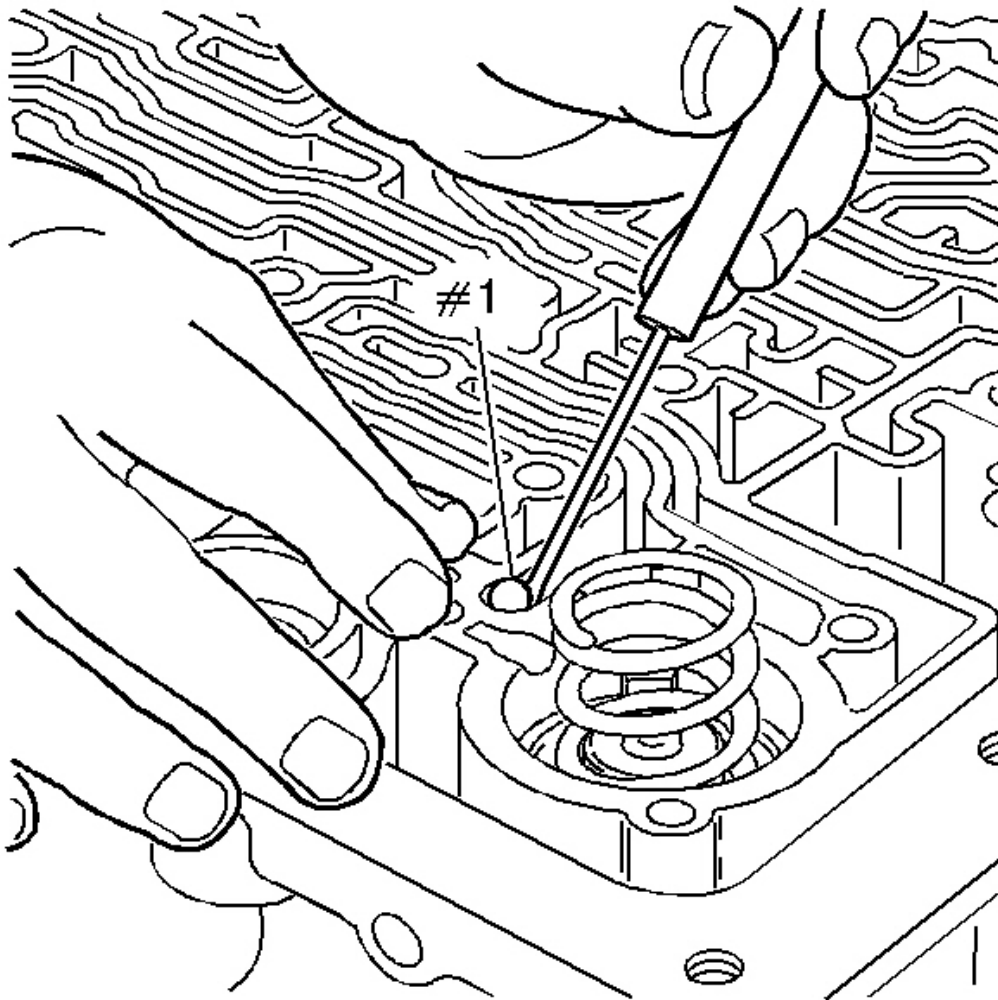

Fig. 217: Locating #1 Checkball
Courtesy of GENERAL MOTORS CORP.

NOTE: Do not use a magnet in order to remove the control valve body ball check valves. This may magnetize the control valve body ball check valves, causing metal particles to stick to them.

20. Remove the #1 case ball check valve.

TURBINE SHAFT O-RING REMOVAL

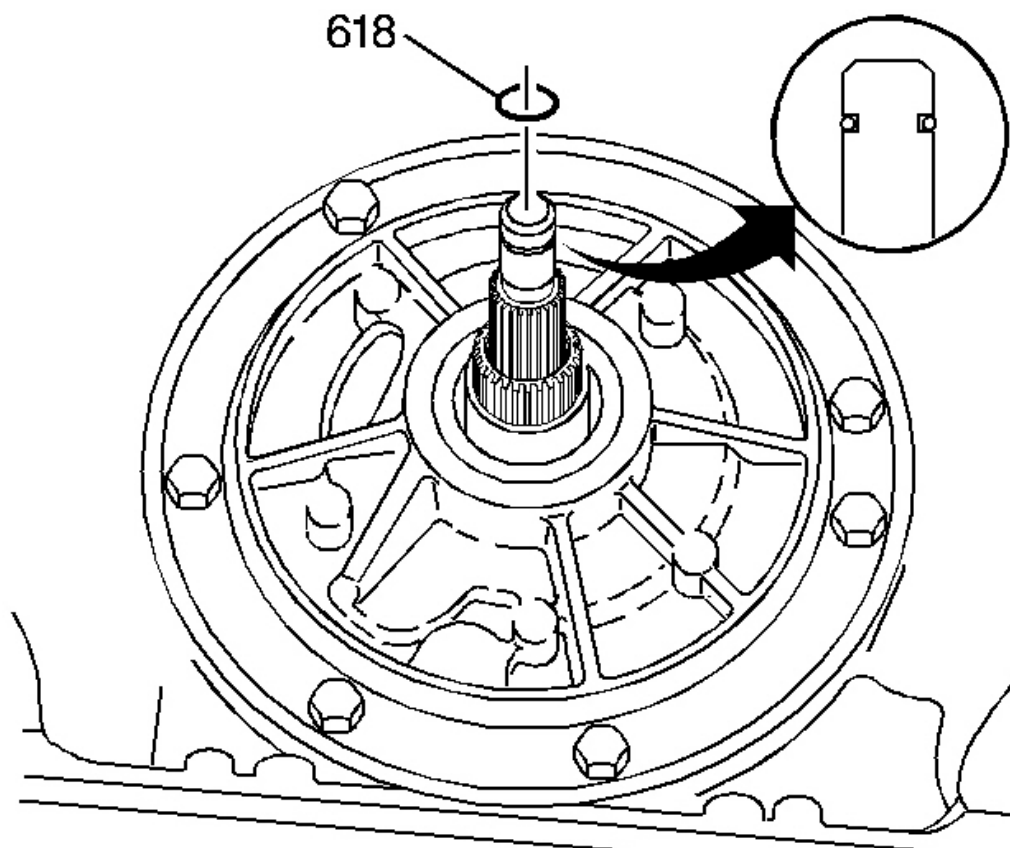

Fig. 218: Identifying Turbine Shaft O-Ring
Courtesy of GENERAL MOTORS CORP.

Remove the O-ring (618) from the turbine shaft. O-Ring location is model dependent.

TRANSMISSION END PLAY CHECK

Tools Required

- **J 25022** End Play Fixture Adapter (245 mm and 258 mm). See **Special Tools**.
- **J 34725** End Play Checking Adapter (298 mm). See **Special Tools**.
- **J 43205** End Play Fixture Adapter (300 mm). See **Special Tools**.
- **J 24773-A** Oil Pump Remover. See **Special Tools**.
- **J 8001** Dial Indicator Set

- **J 25025-7A** Dial Indicator Mounting Post. See Special Tools.

Procedure

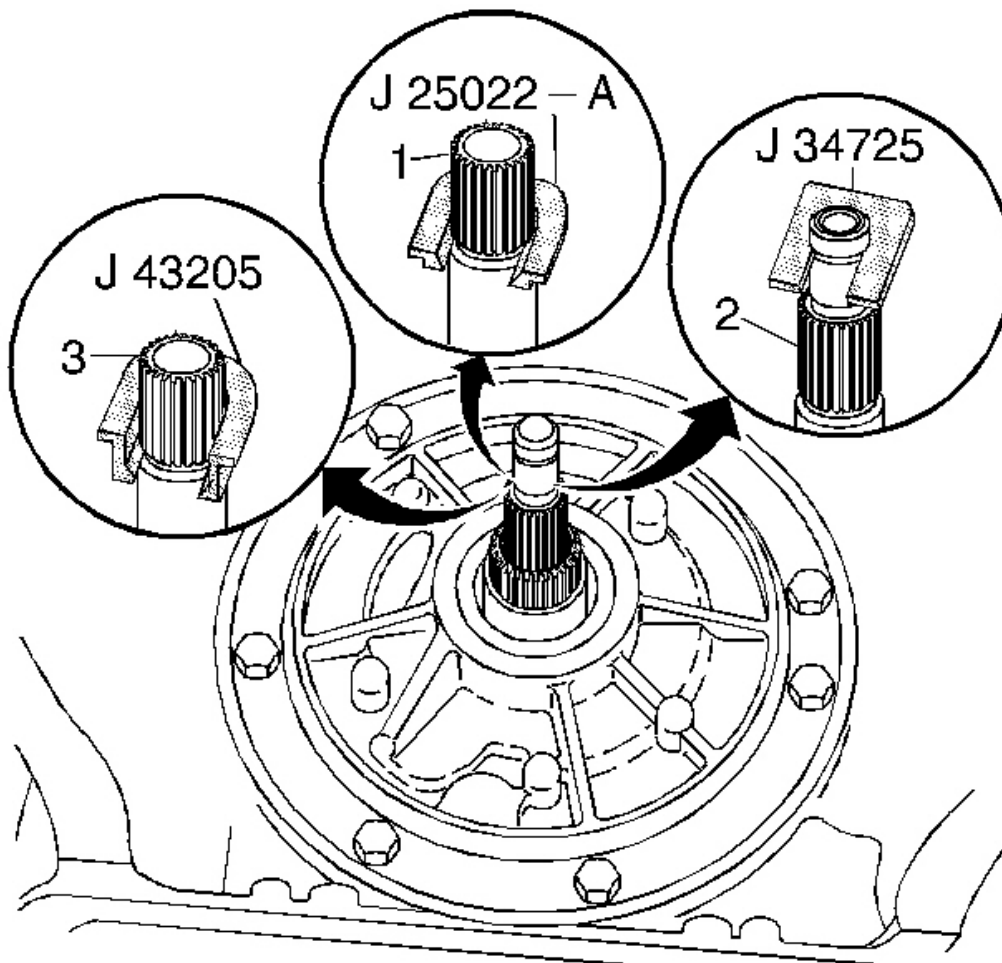

Fig. 219: Identifying Different End Play Fixture Adapters
Courtesy of GENERAL MOTORS CORP.

IMPORTANT: Torque converter size is model dependent.

1. Install an end play fixture adapter.

- Use **J 25022** for a 245 mm and 258 mm turbine shaft (1). See Special Tools.

2007 Hummer H3

2007 TRANSMISSION Automatic Transmission - 4L60-E/4L65-E/4L70-E - H3

- Use **J 34725** for a 298 mm turbine shaft (2). See **Special Tools**.
- Use **J 43205** for a 300 mm turbine shaft (3). See **Special Tools**.

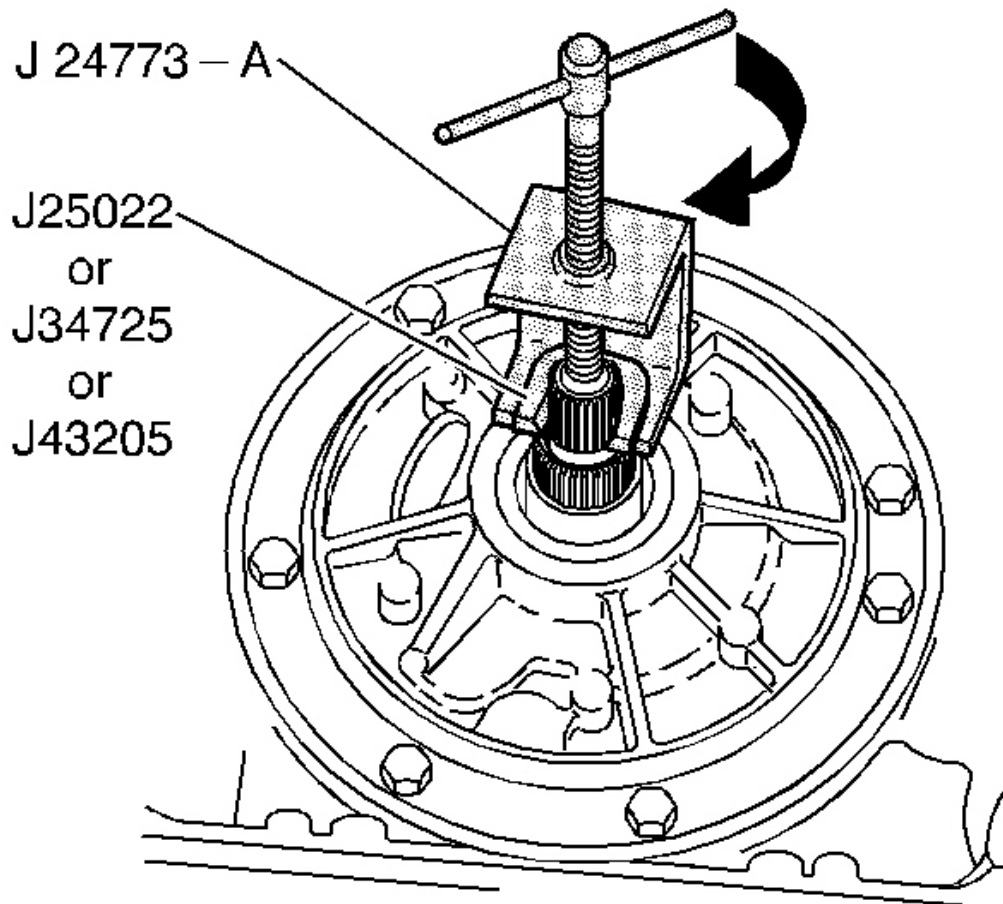

Fig. 220: Identifying J 24773-A
Courtesy of GENERAL MOTORS CORP.

2. Install the **J 24773-A** . See **Special Tools**.

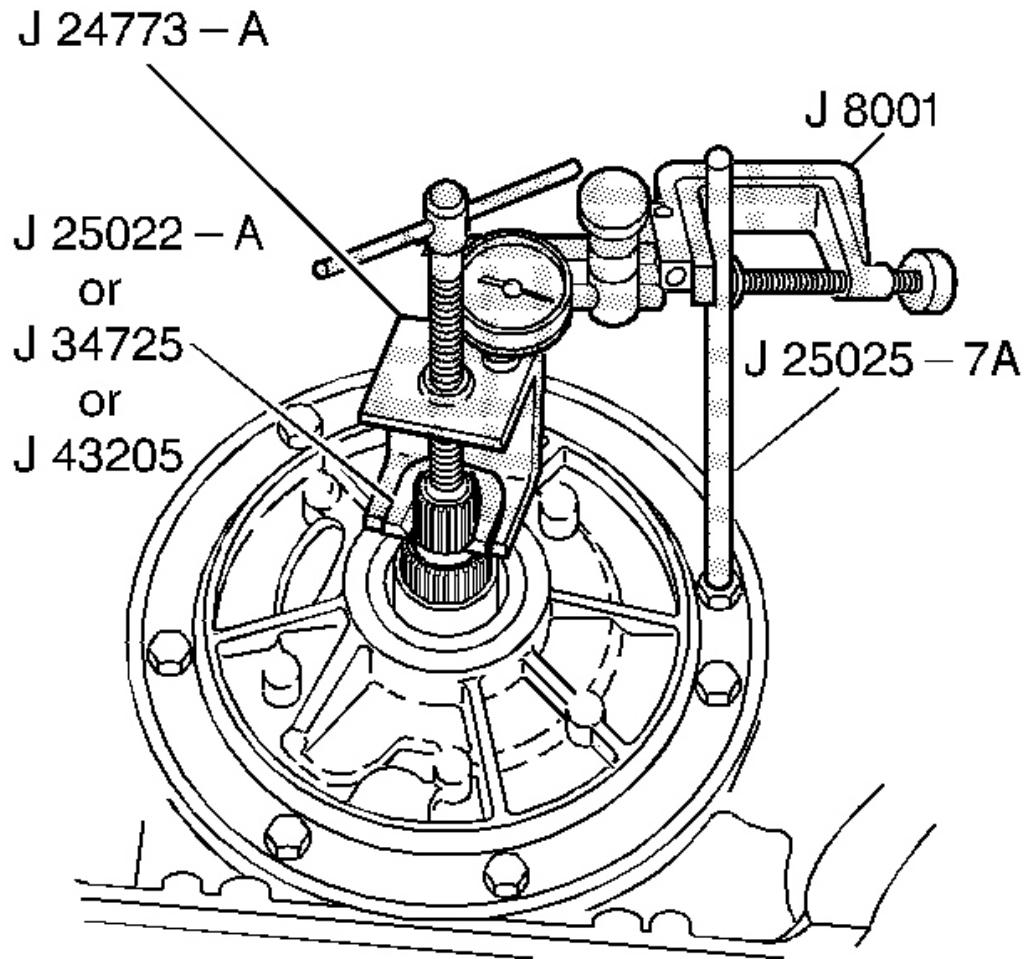

Fig. 221: Installing J 25025-7A With J 8001
Courtesy of GENERAL MOTORS CORP.

3. Remove an oil pump bolt.
4. Install **J 25025-7A** (or a 278 mm or 11 in bolt) and lock nut. See **Special Tools**.
5. Install **J 8001** .

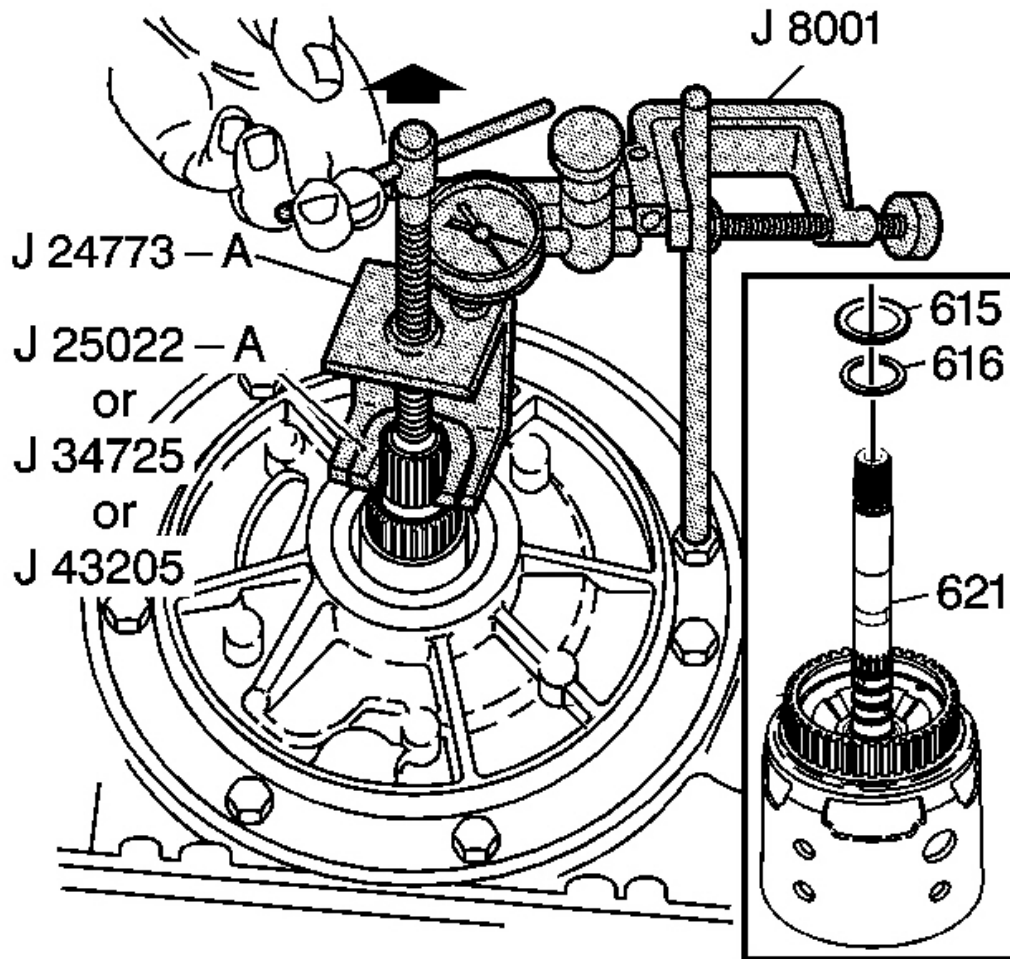

Fig. 222: Installing J 8001 & Setting It To Zero
 Courtesy of GENERAL MOTORS CORP.

6. Set the **J 8001** to zero.
7. Pull up on **J 24773-A** . See **Special Tools**.

Proper end play should be 0.13-0.92 mm (0.005-0.036 in).

8. The selective thrust washer (616), which controls the end play, is located between the input housing (621) and the thrust bearing (615) on the oil pump hub.

2007 Hummer H3

2007 TRANSMISSION Automatic Transmission - 4L60-E/4L65-E/4L70-E - H3

If the end play measurement is incorrect, refer to **End Play Specifications** . Choose a new selective thrust washer (616) based on the original selective washer and the information contained in the table.

If the dial indicator shows no end play, the selective thrust washer (616) and thrust bearing (615) may have been misassembled.

9. Correct the end play by changing the selective thrust washer (616).

OIL PUMP REMOVAL

Tools Required

J 45053 Universal Clamp Press. See **Special Tools**.

Removal Procedure

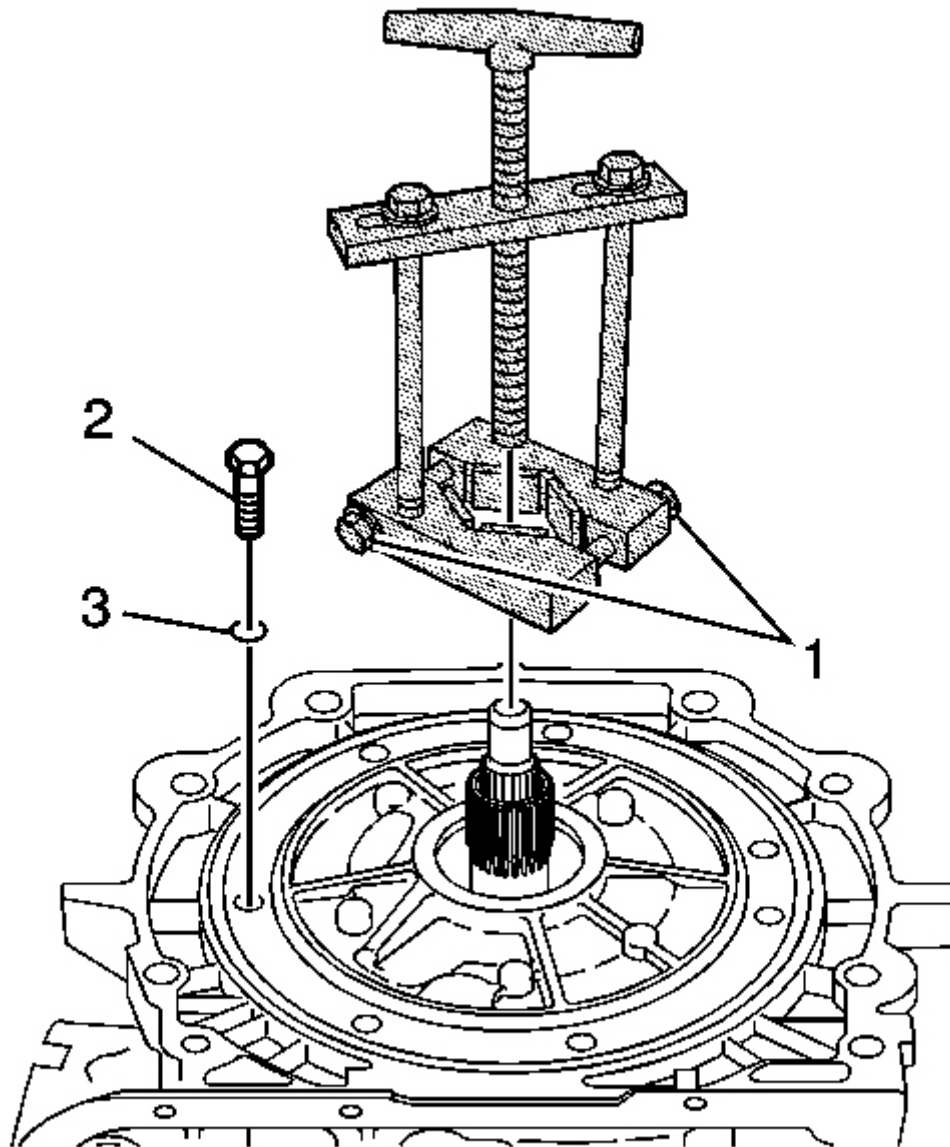

Fig. 223: Locating Pump Bolts & Seals
Courtesy of GENERAL MOTORS CORP.

1. Remove all pump bolts (2) and pump bolt seal (3).
2. Install **J 45053** over stator shaft. See **Special Tools**. Tighten the clamp bolts (1).

3. To prevent slipping, securely fasten the **J 45053** around the stator shaft by tightening the bolts (1) with a wrench. See **Special Tools**.

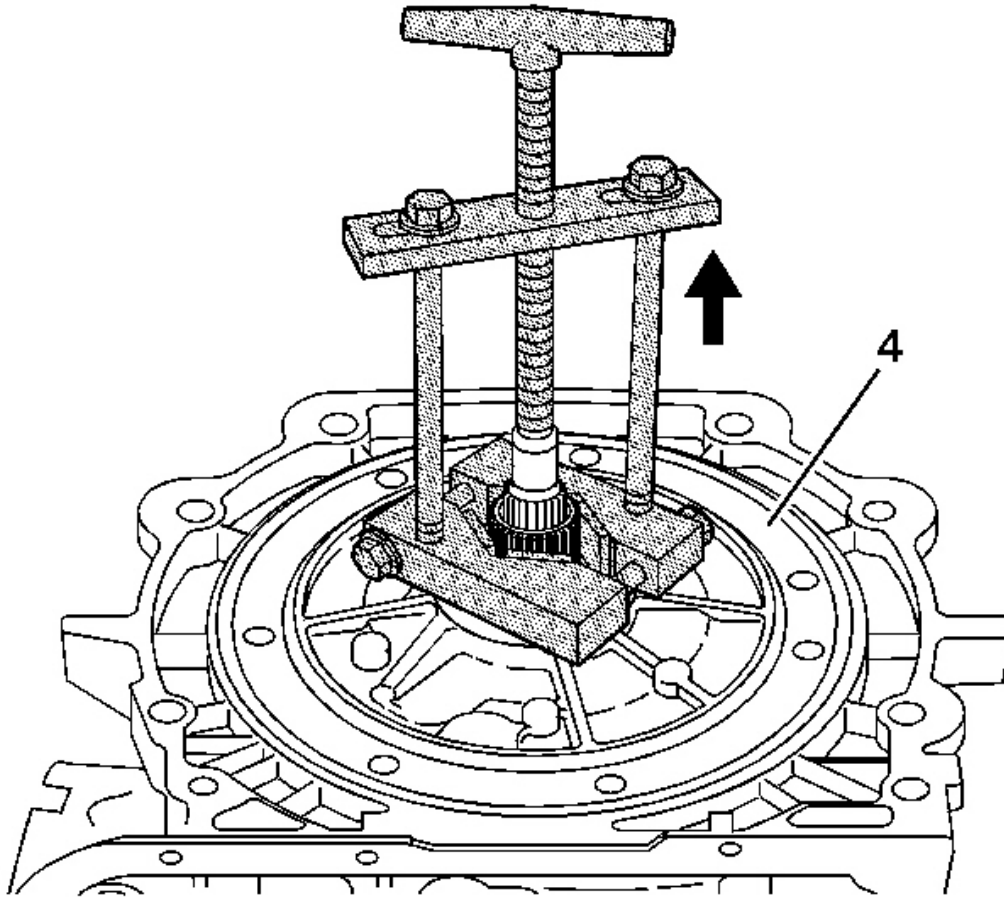

Fig. 224: Removing Pump Assembly
Courtesy of GENERAL MOTORS CORP.

4. Turn the T-handle of the **J 45053** to pull the pump assembly (4) from the case. See **Special Tools**.
5. Lift the pump (4) out of the case.

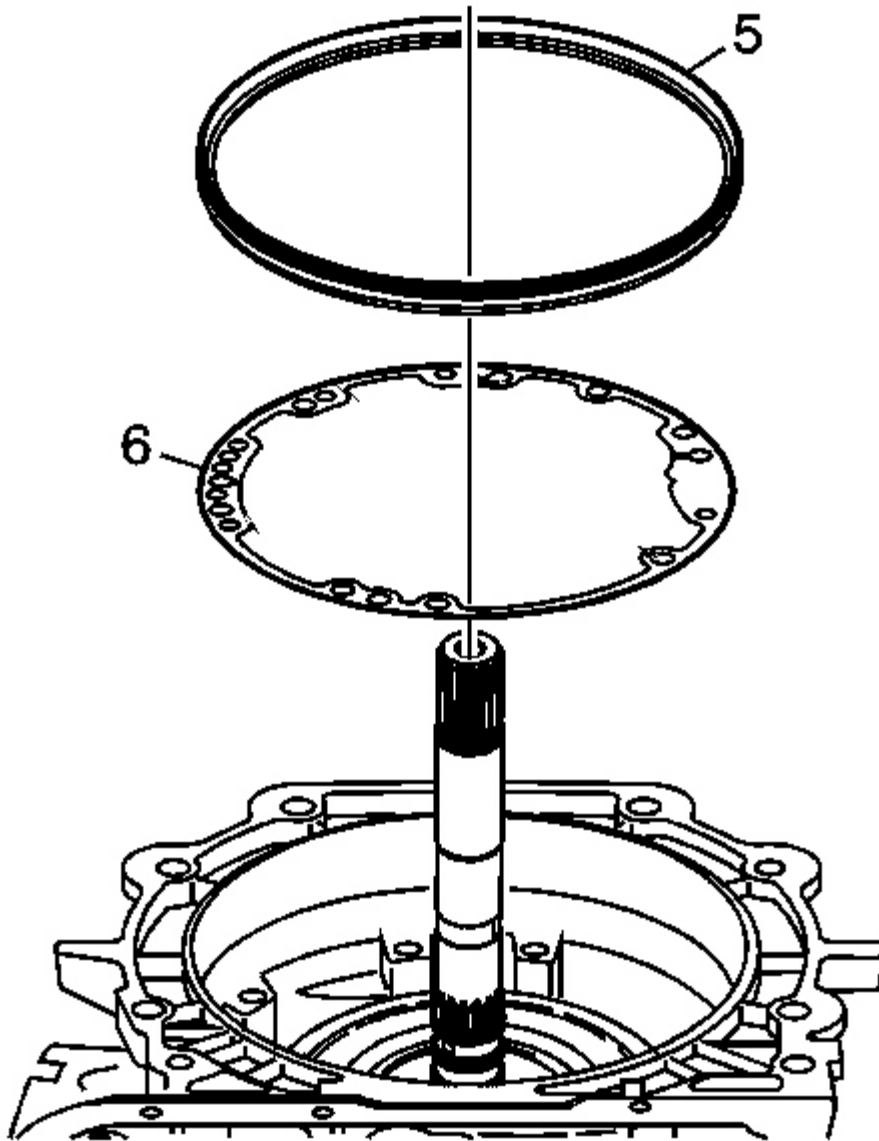

Fig. 225: View Of Fluid Pump Seal & Gasket
Courtesy of GENERAL MOTORS CORP.

6. Remove the fluid pump seal (5).
7. Remove the pump cover to case gasket (6).

2-4 BAND, INPUT CLUTCHES, INPUT GEAR SET REMOVAL

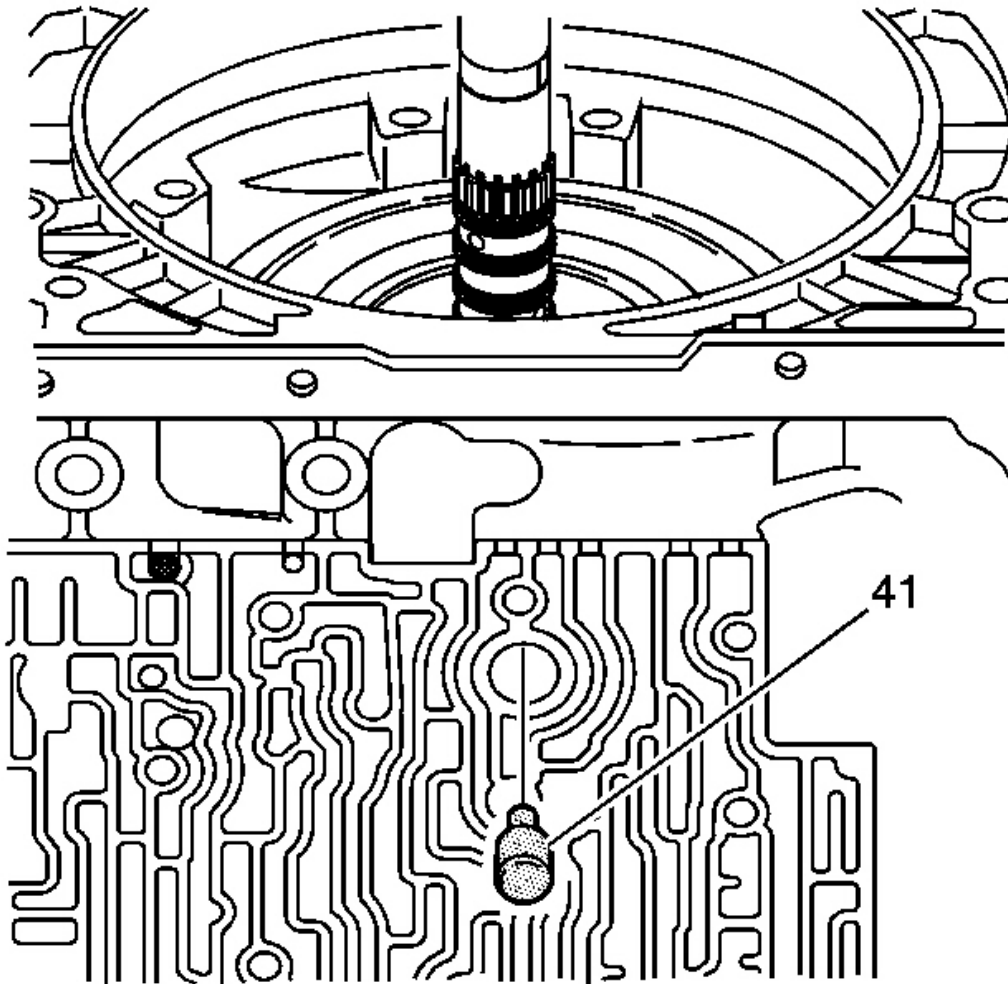

Fig. 226: Identifying Band Anchor Pin
Courtesy of GENERAL MOTORS CORP.

1. Remove the band anchor pin (41).

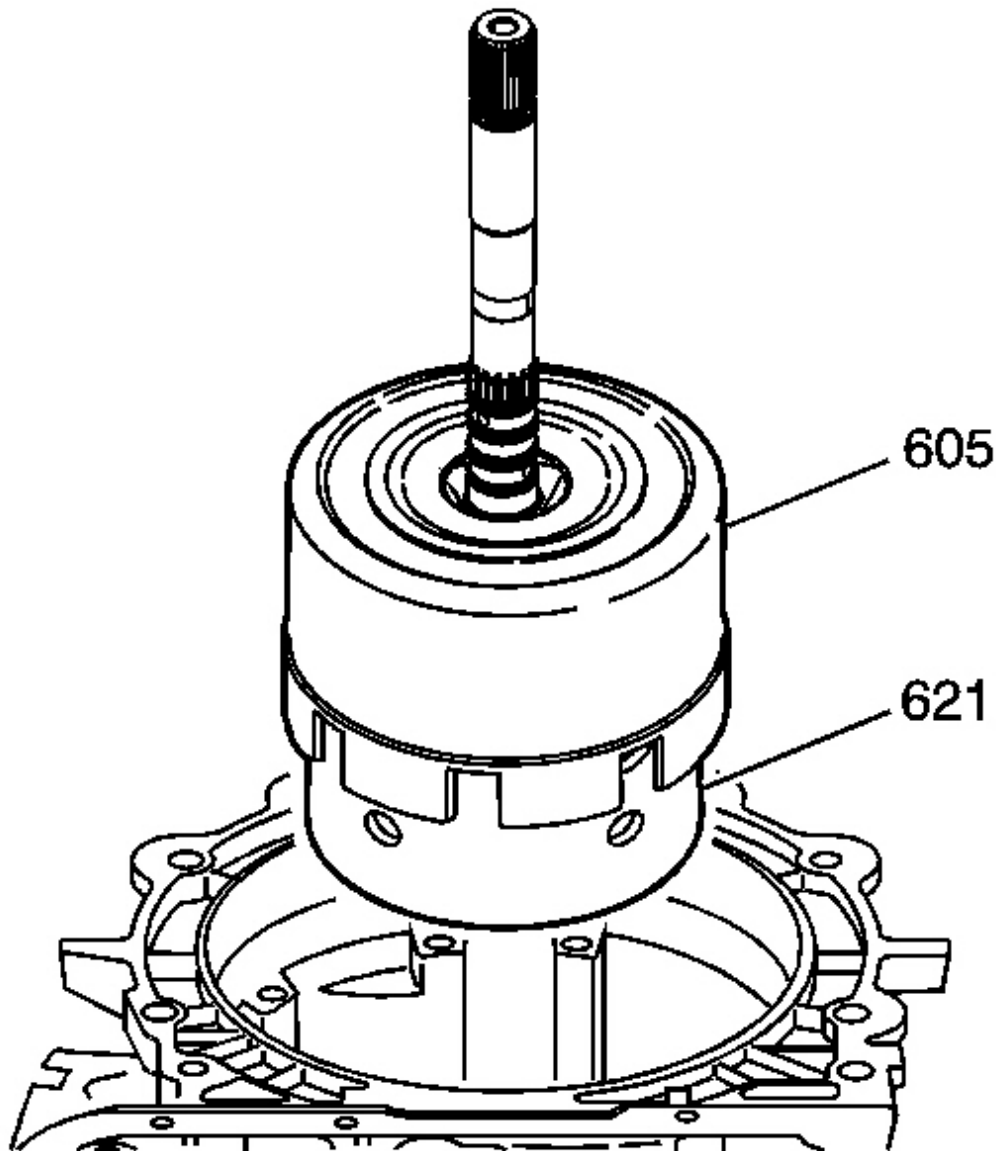

Fig. 227: Identifying Reverse Input Clutch Assembly & Input Housing
Courtesy of GENERAL MOTORS CORP.

2. Remove the input housing and shaft assembly (621), along with the reverse input clutch housing and drum assembly (605).

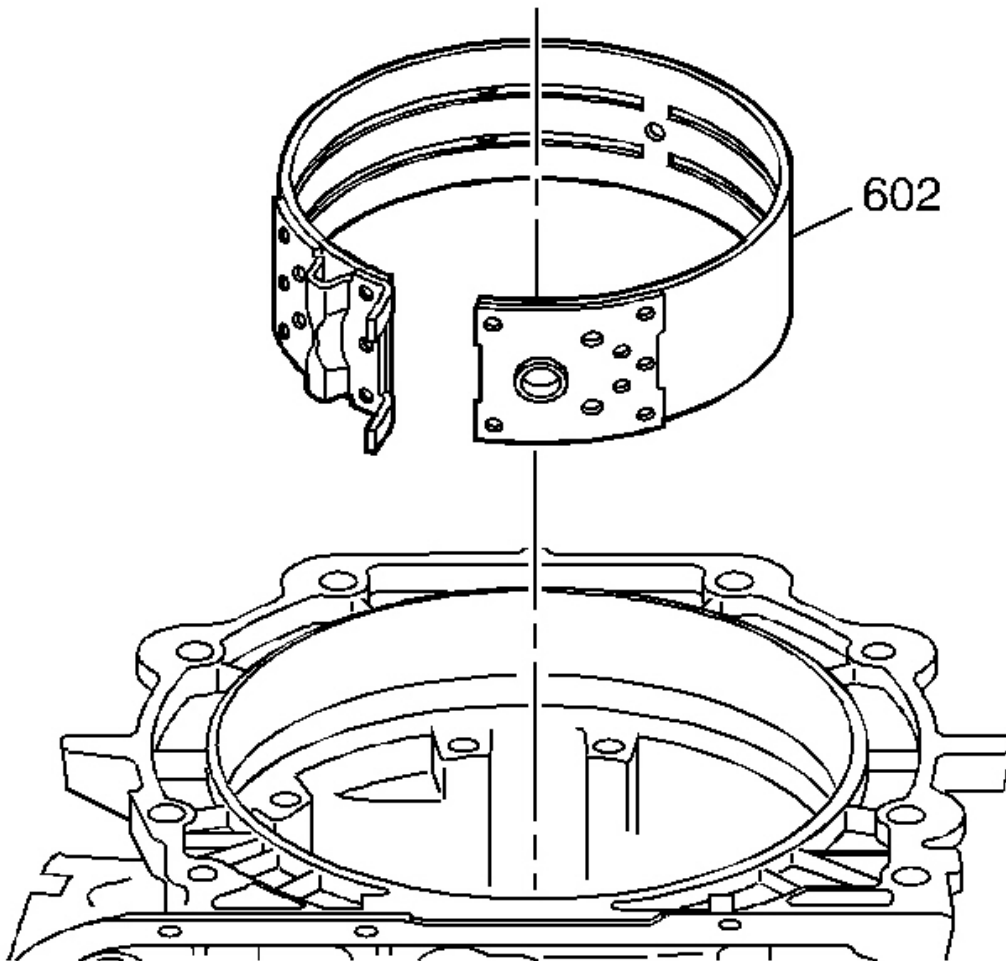

Fig. 228: View Of 2-4 Band Assembly
Courtesy of GENERAL MOTORS CORP.

3. Remove the 2-4 band assembly (602).

REACTION GEAR SET REMOVAL

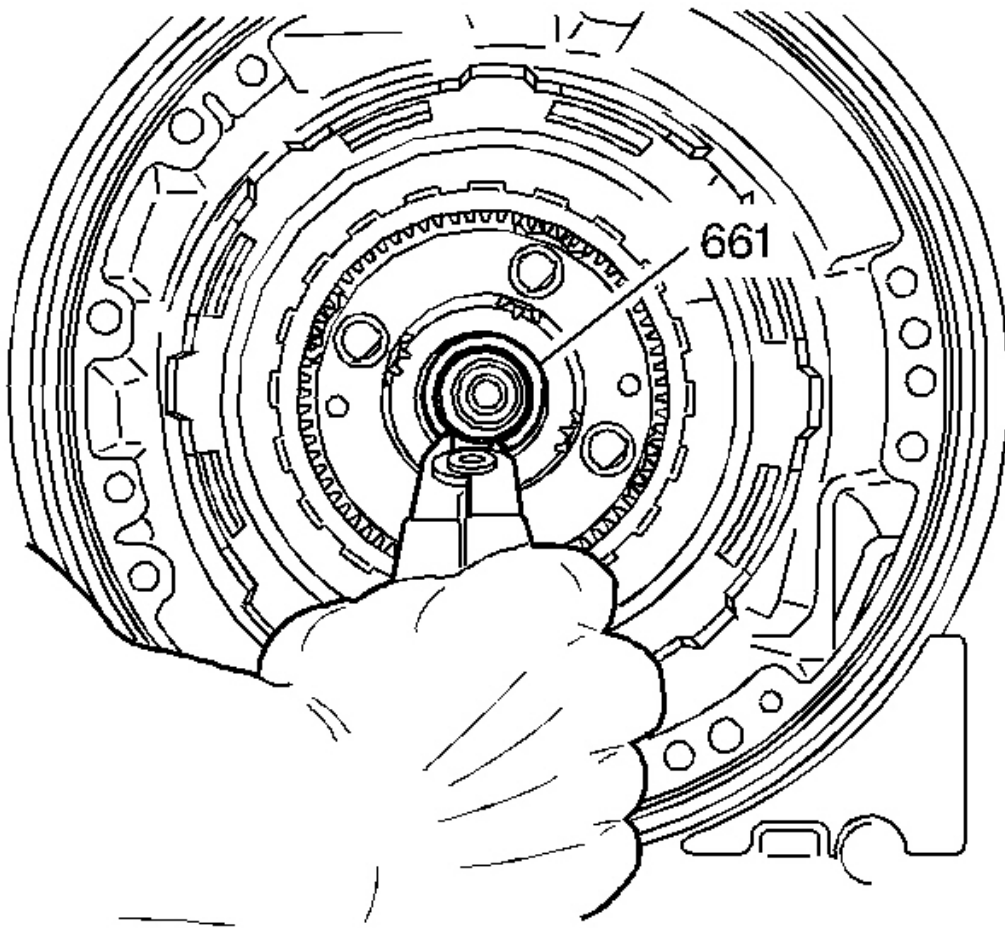

Fig. 229: View Of Output Shaft To Input Carrier Retainer
Courtesy of GENERAL MOTORS CORP.

IMPORTANT: The output shaft retainer ring (661) can not be reused, it must be replaced.

1. Use snap ring pliers to remove the output shaft retainer ring (661).

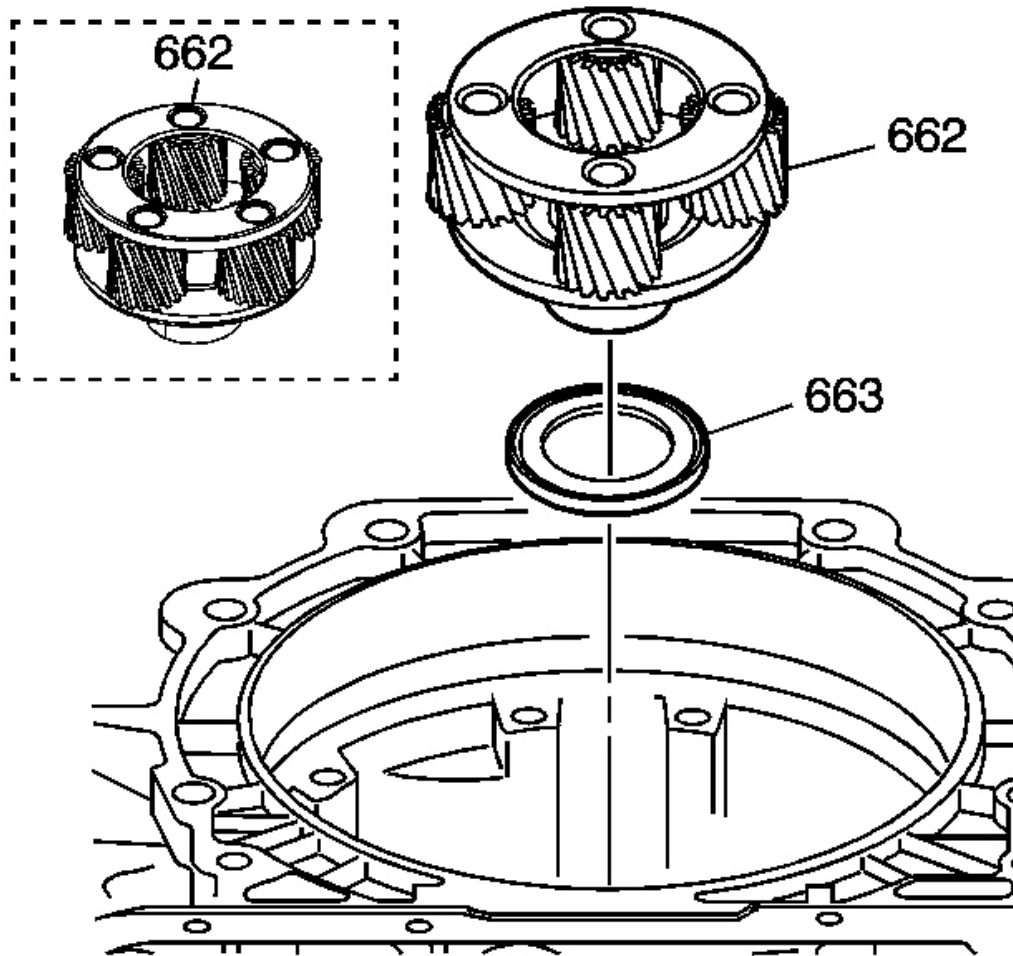

Fig. 230: Identifying Input Carrier Assembly
Courtesy of GENERAL MOTORS CORP.

IMPORTANT: The carrier assembly (662) can be a 4 or 5 pinion design depending on transmission model.

2. Remove the input carrier assembly (662) and remove the thrust bearing assembly (663).

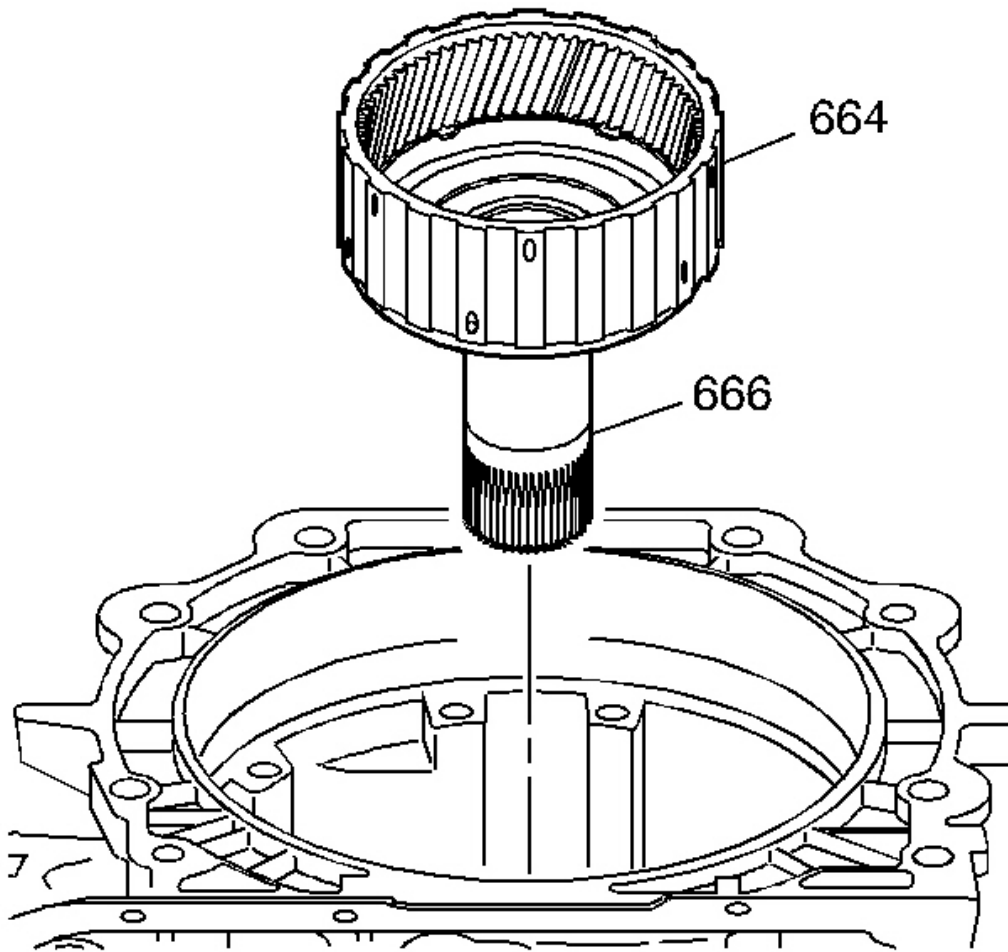

Fig. 231: Reaction Carrier Shaft Assembly & Input Internal Gear
Courtesy of GENERAL MOTORS CORP.

3. Remove the input internal gear (664) and the reaction carrier shaft assembly (666).

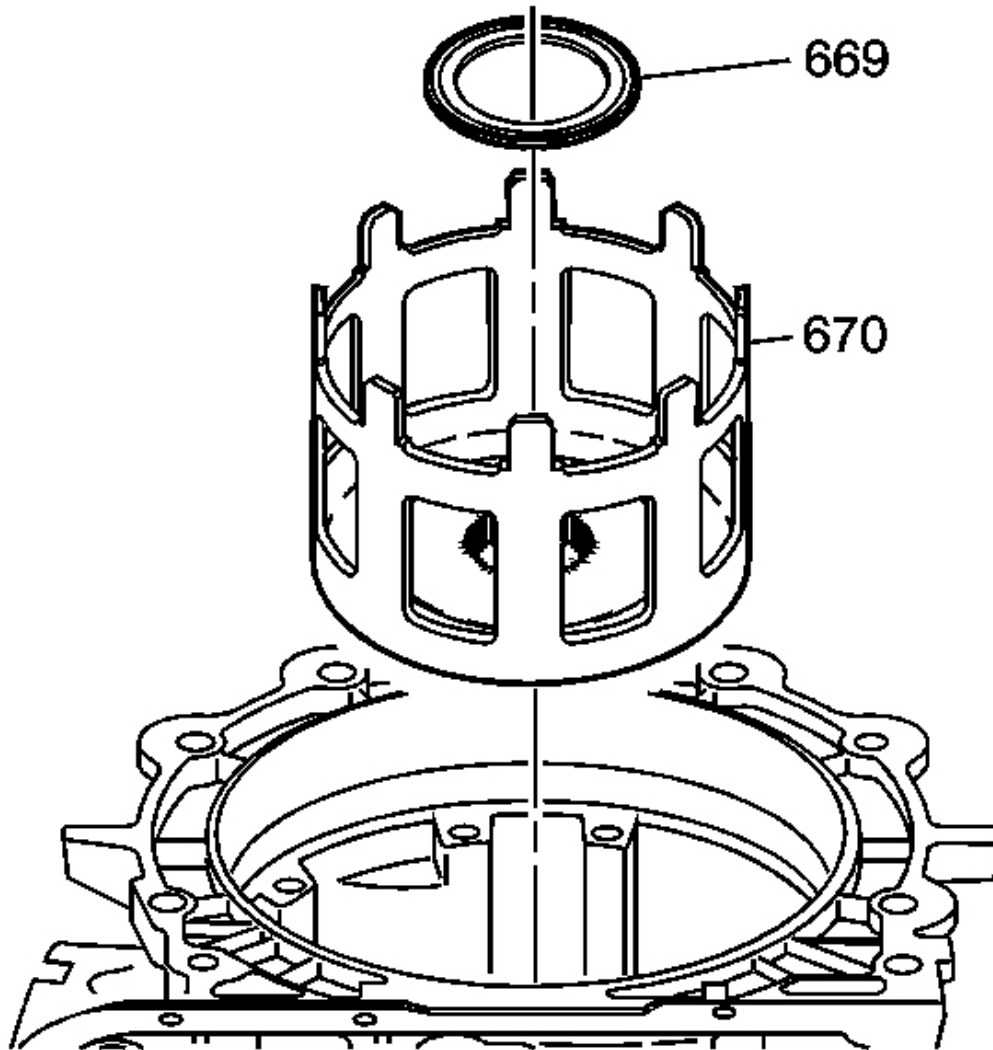

Fig. 232: View Of Thrust Washer & Reaction Sun Shell
Courtesy of GENERAL MOTORS CORP.

4. Remove the thrust washer (669) and the reaction sun shell (670).

OUTPUT SHAFT, REACTION GEAR, LOW/REV CLUTCH REMOVAL

Tools Required

J 29837-A Output Shaft Support Fixture. See Special Tools.

Removal Procedure

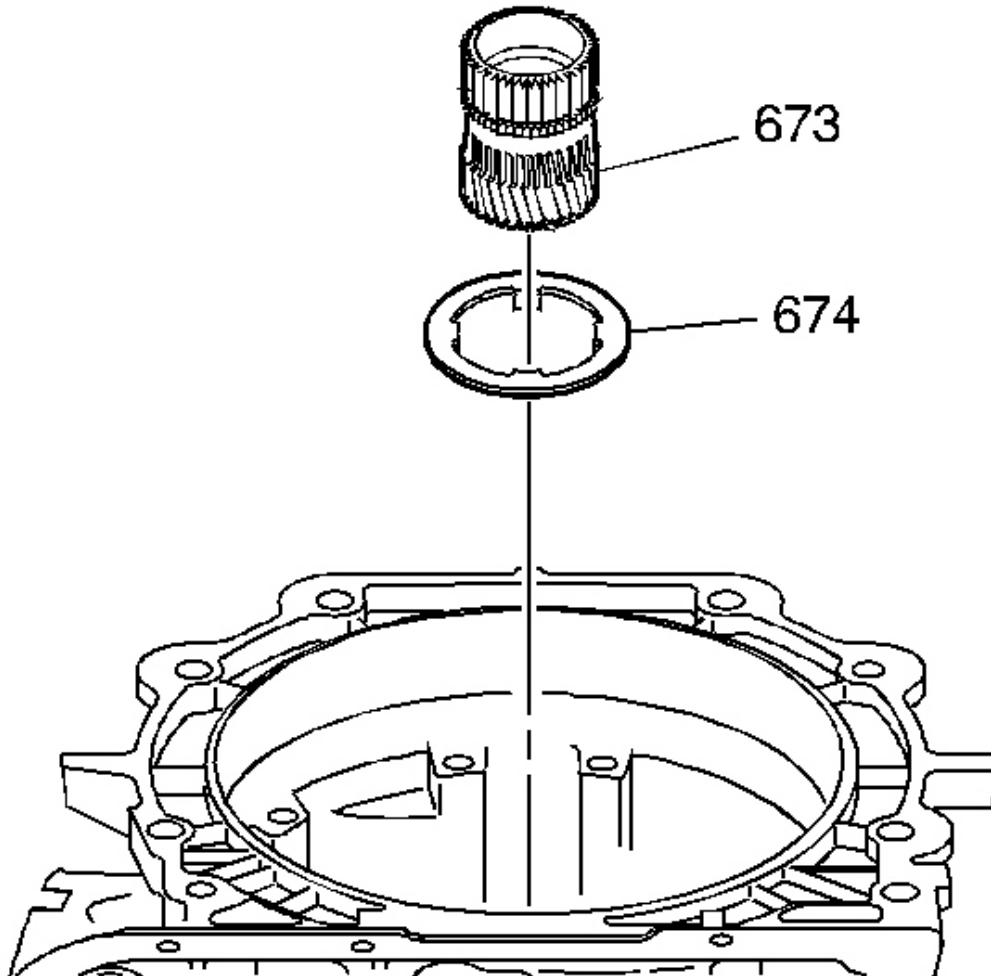

Fig. 233: Identifying Reaction Sun Gear & Thrust Washer
Courtesy of GENERAL MOTORS CORP.

1. Remove the reaction sun gear (673) and the thrust washer (674).

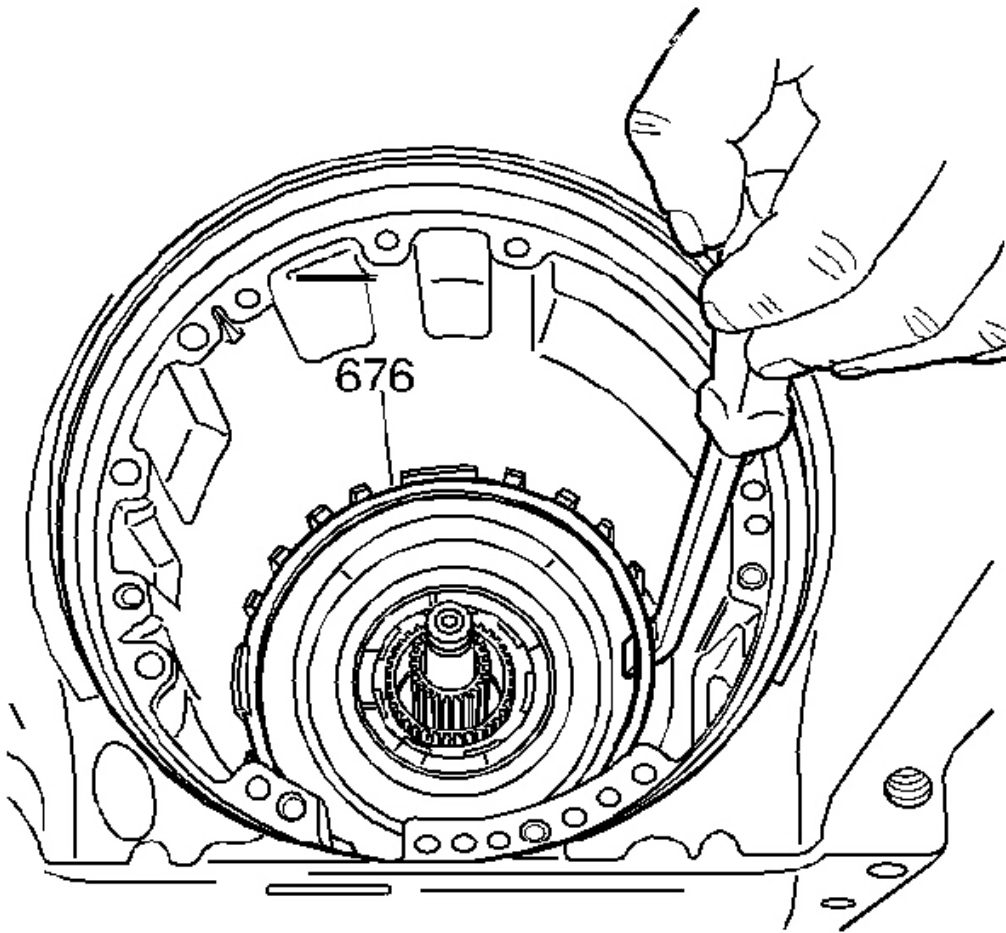

Fig. 234: Removing Low And Reverse Support Retainer Ring
Courtesy of GENERAL MOTORS CORP.

2. Remove the low and reverse support retainer ring (676).

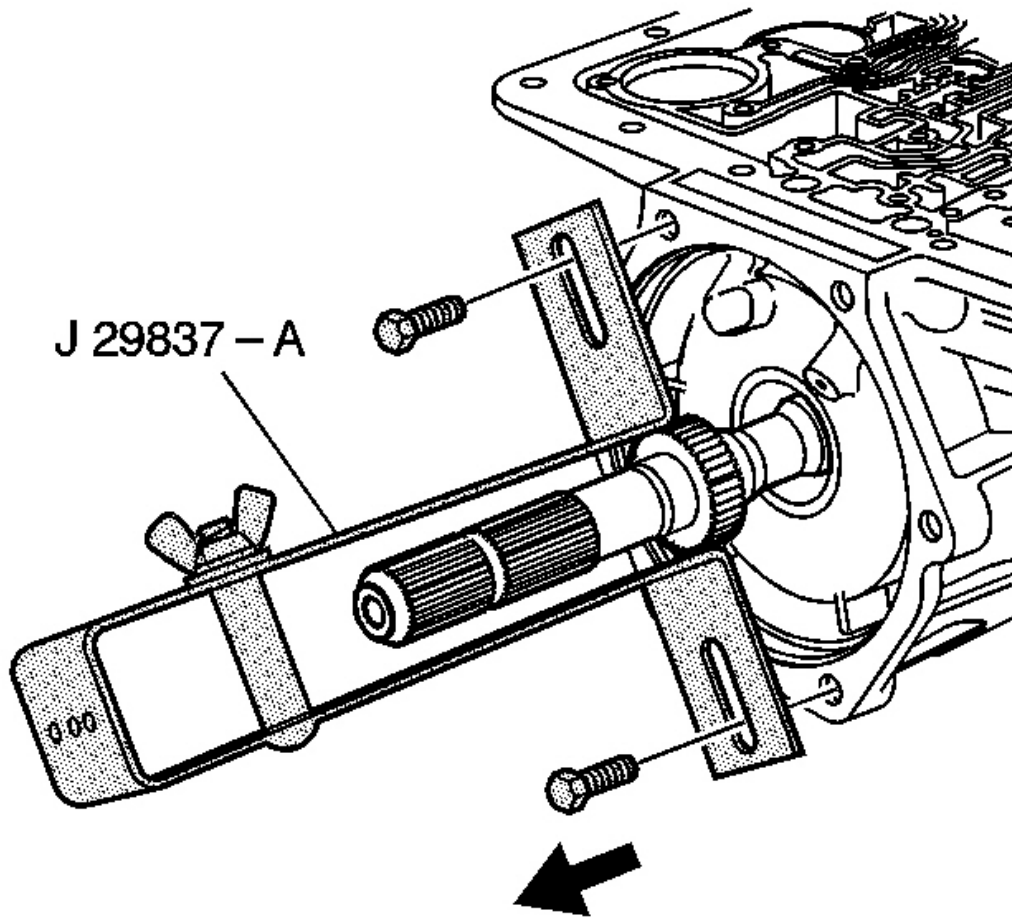

Fig. 235: Identifying J 29837-A
Courtesy of GENERAL MOTORS CORP.

3. Remove the J 29837-A . See Special Tools.

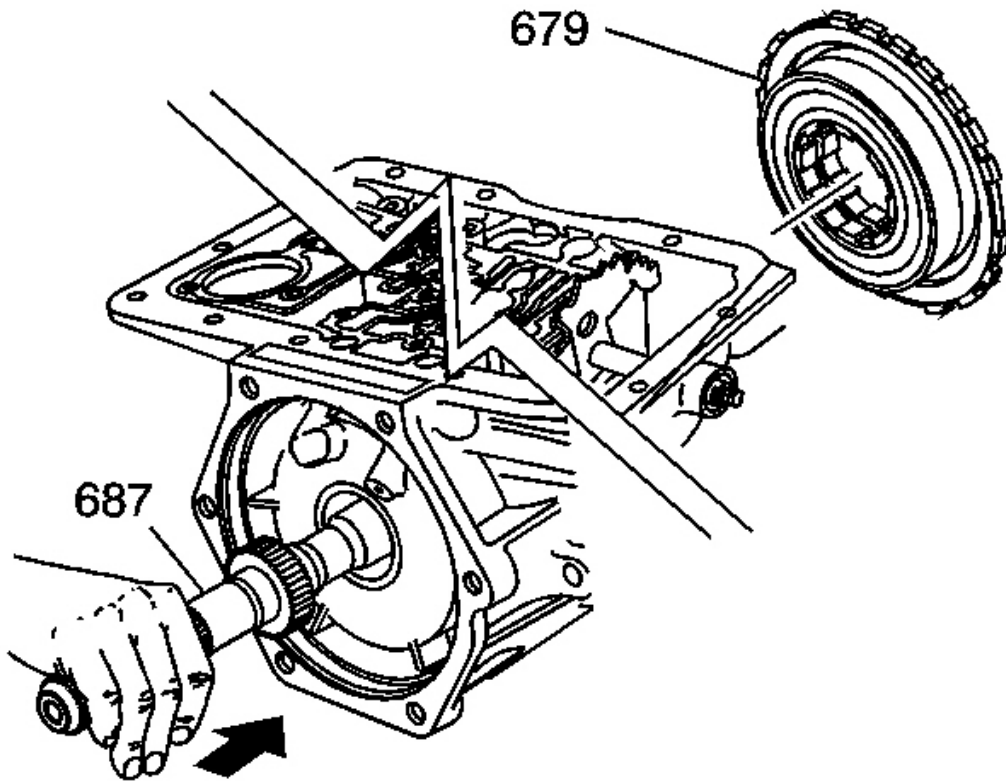

Fig. 236: View Of Low And Reverse Clutch Support
Courtesy of GENERAL MOTORS CORP.

4. Push on the output shaft (687) in order to loosen the low and reverse clutch support (679).
5. Remove the low and reverse clutch support (679).

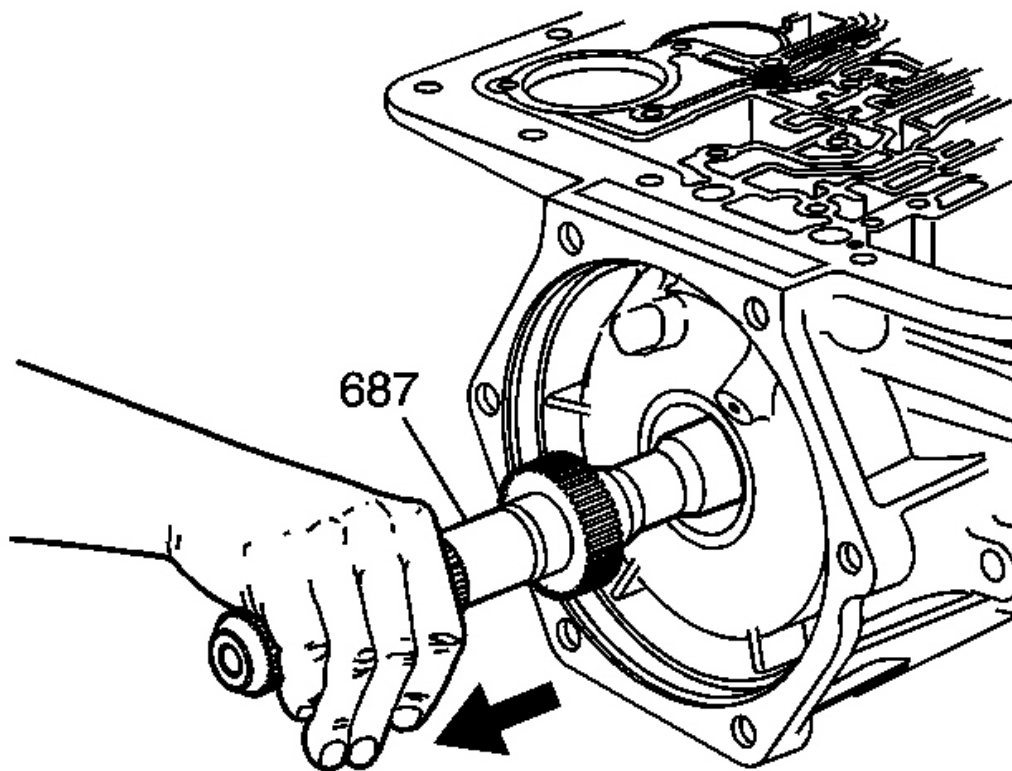

Fig. 237: Locating Output Shaft
Courtesy of GENERAL MOTORS CORP.

6. Remove the output shaft (687).

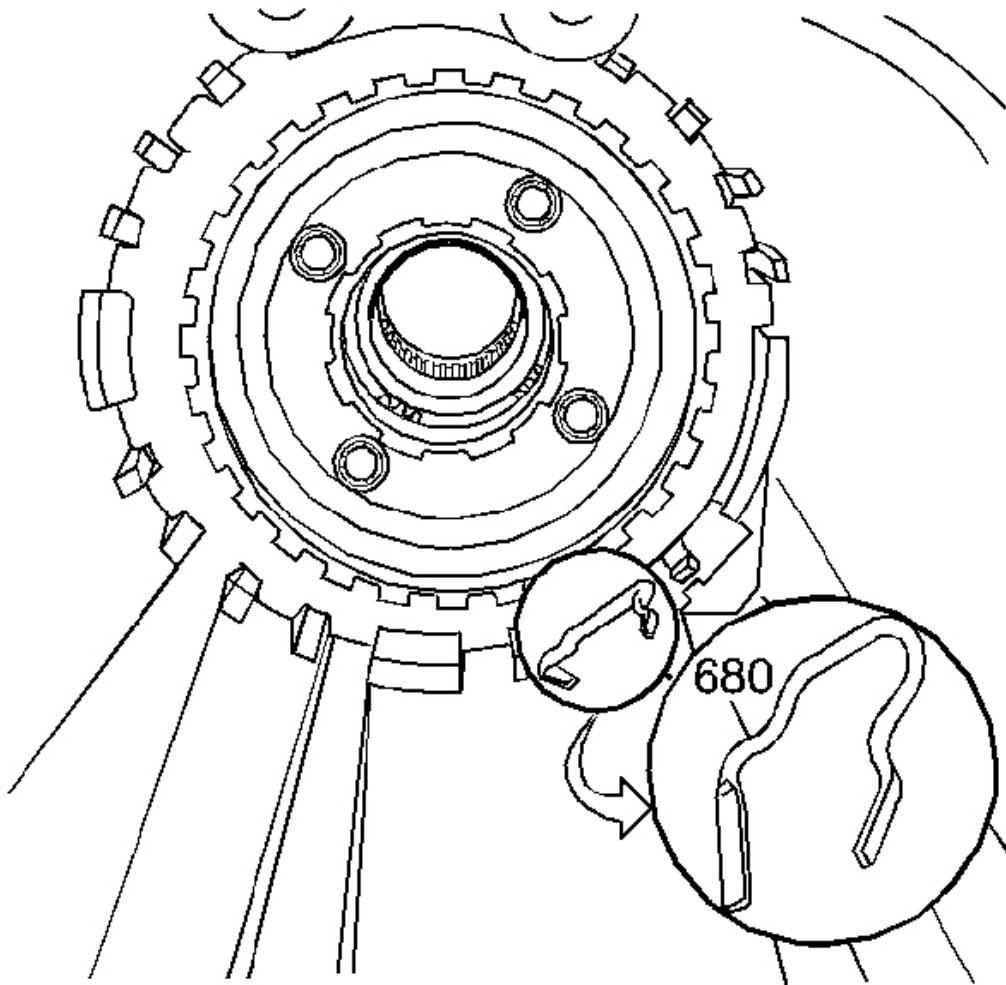

Fig. 238: View Of Low And Reverse Clutch Support Retainer Spring
Courtesy of GENERAL MOTORS CORP.

7. Remove the low and reverse clutch support retainer spring (680).

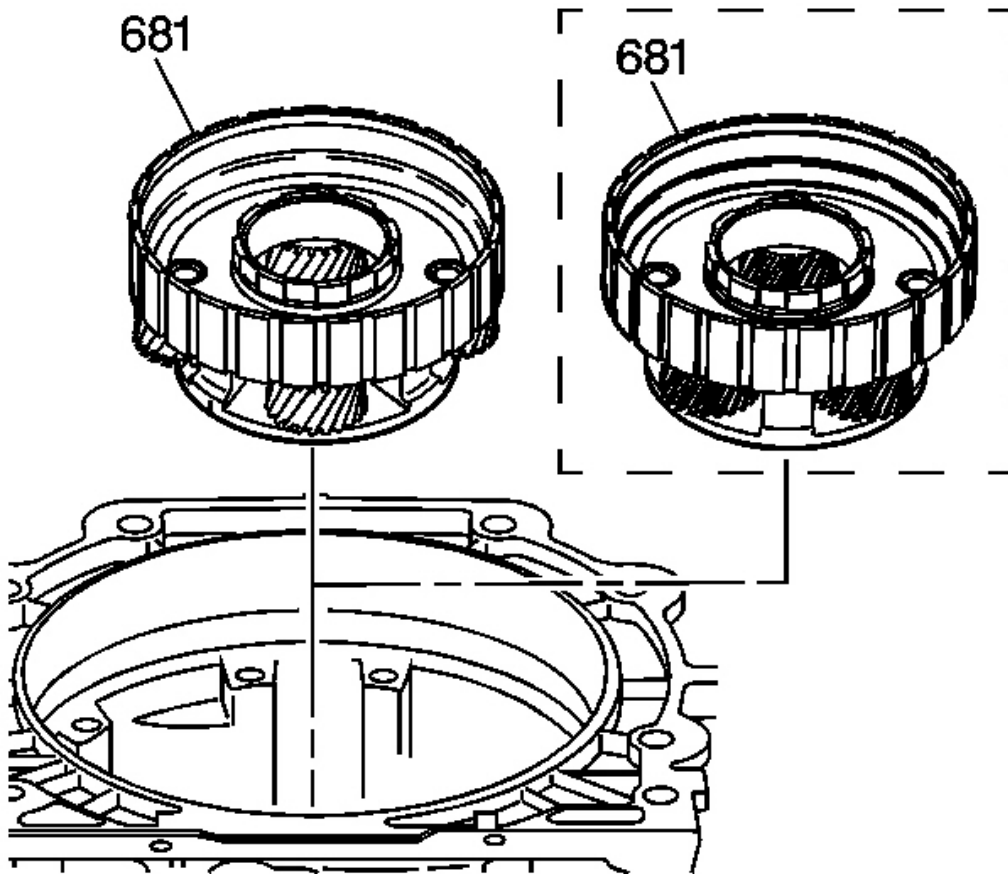

Fig. 239: Identifying Reaction Carrier Assembly
Courtesy of GENERAL MOTORS CORP.

IMPORTANT: The reaction carrier assembly (681) can be a 4 or 5 pinion design depending on the transmission model.

8. Remove the reaction carrier assembly (681).

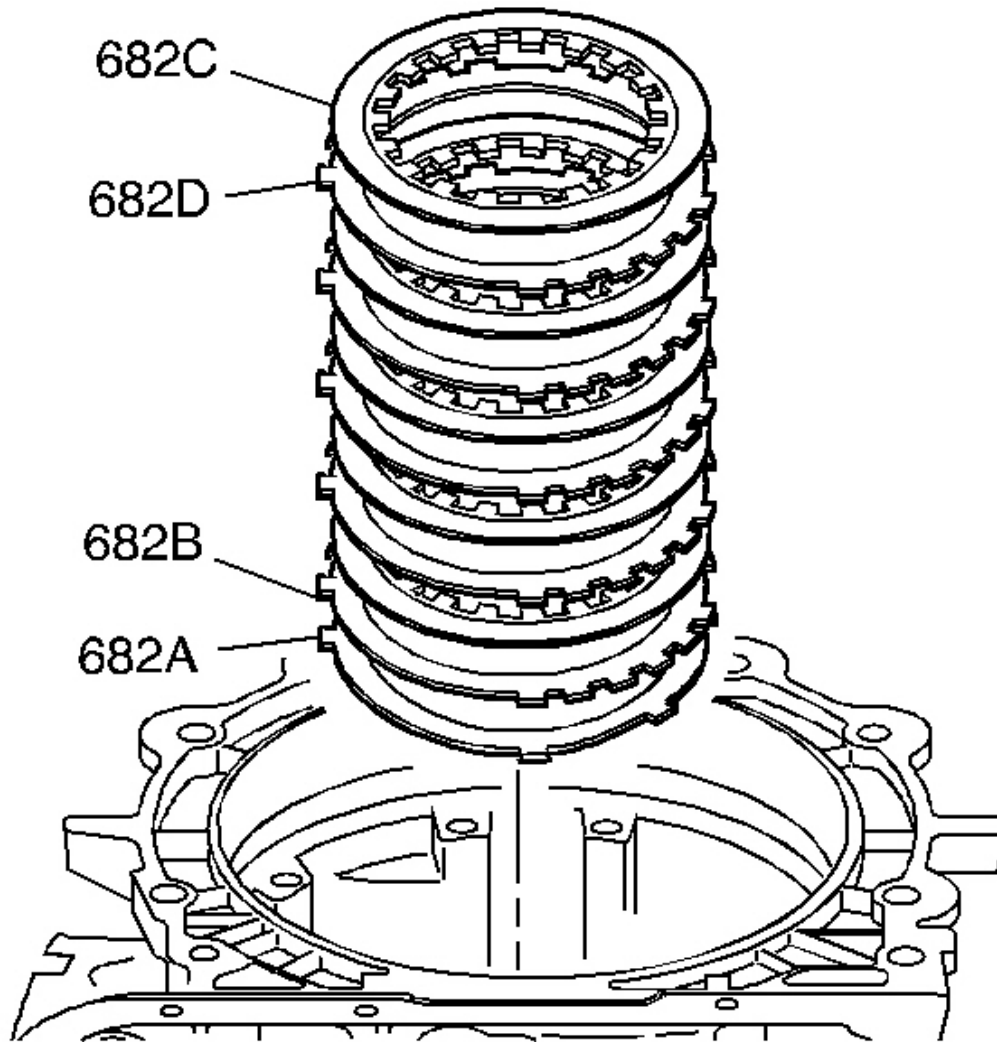

Fig. 240: Locating Low And Reverse Clutch Components
Courtesy of GENERAL MOTORS CORP.

9. Remove the following components:
 1. The low and reverse clutch fiber plate assembly (682C)
 2. The low and reverse clutch steel plates (682D)
 3. The low and reverse clutch selective plate (682B)
 4. The low and reverse clutch waved plate (682A)

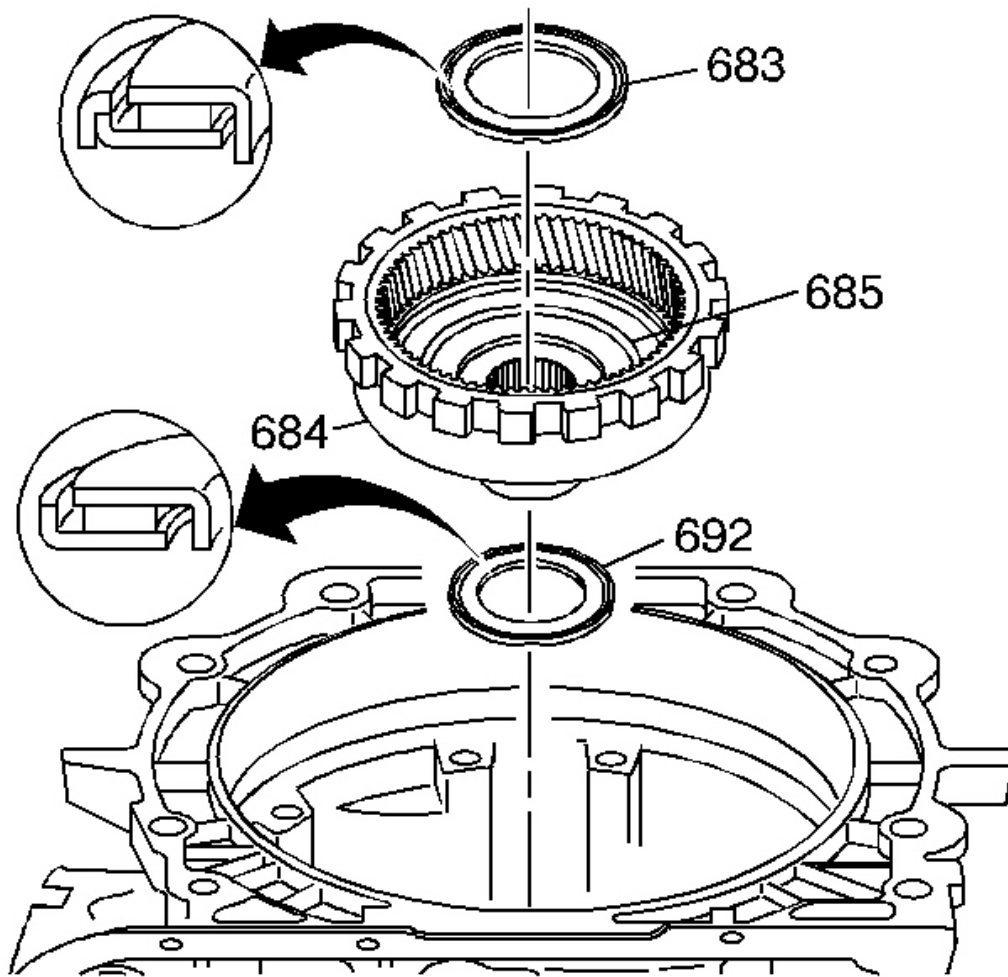

Fig. 241: View Of Reaction Carrier/Support Thrust Bearing Assembly
Courtesy of GENERAL MOTORS CORP.

10. Remove the following components:
 1. The thrust bearing assembly (reaction carrier support) (683)
 2. The internal reaction gear (684) and the internal reaction gear support (685)
 3. The reaction gear support bearing (692)

INNER MANUAL LINKAGE REMOVAL

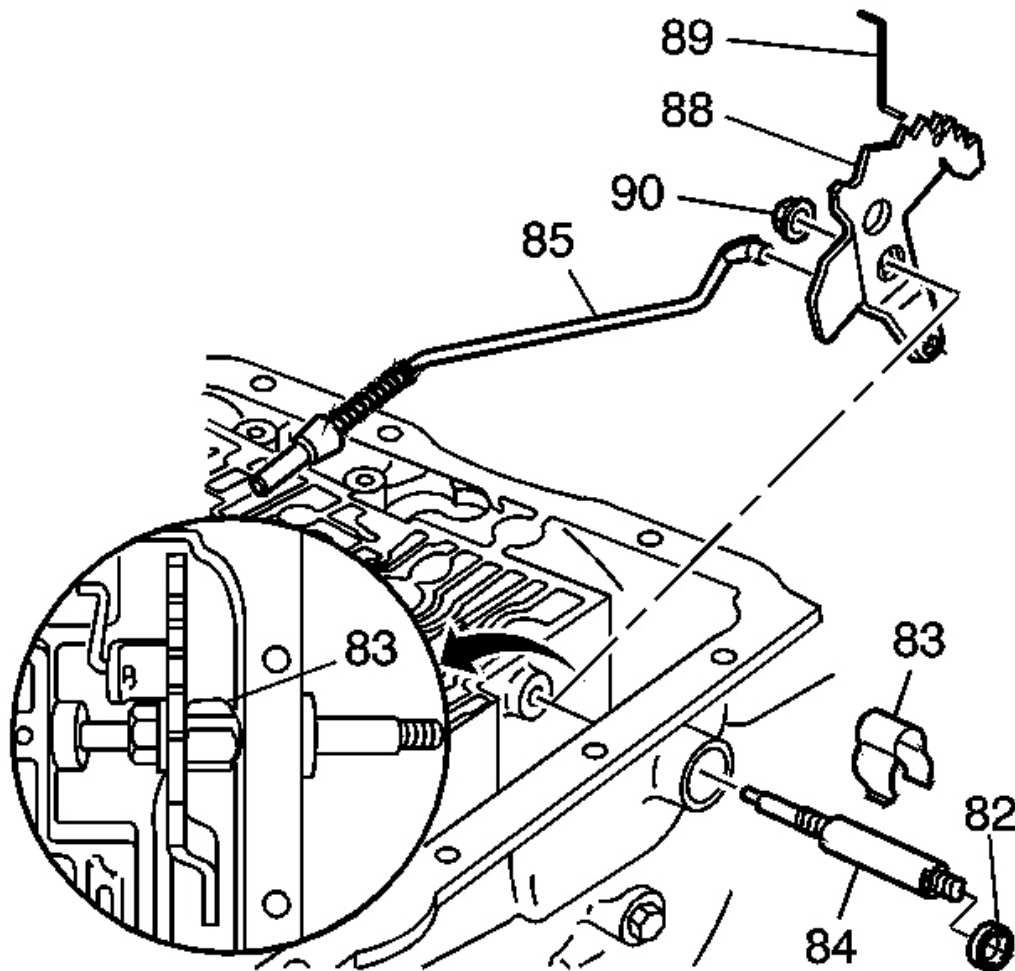

Fig. 242: Inspecting Inner Manual Linkage
Courtesy of GENERAL MOTORS CORP.

1. Remove the following parts:
 1. Hex head nut (90)
 2. Manual valve link (89)
 3. Detent lever (88)
 4. Parking lock actuator assembly (85)
 5. Manual shaft retainer (83)
 6. Manual shaft (84)

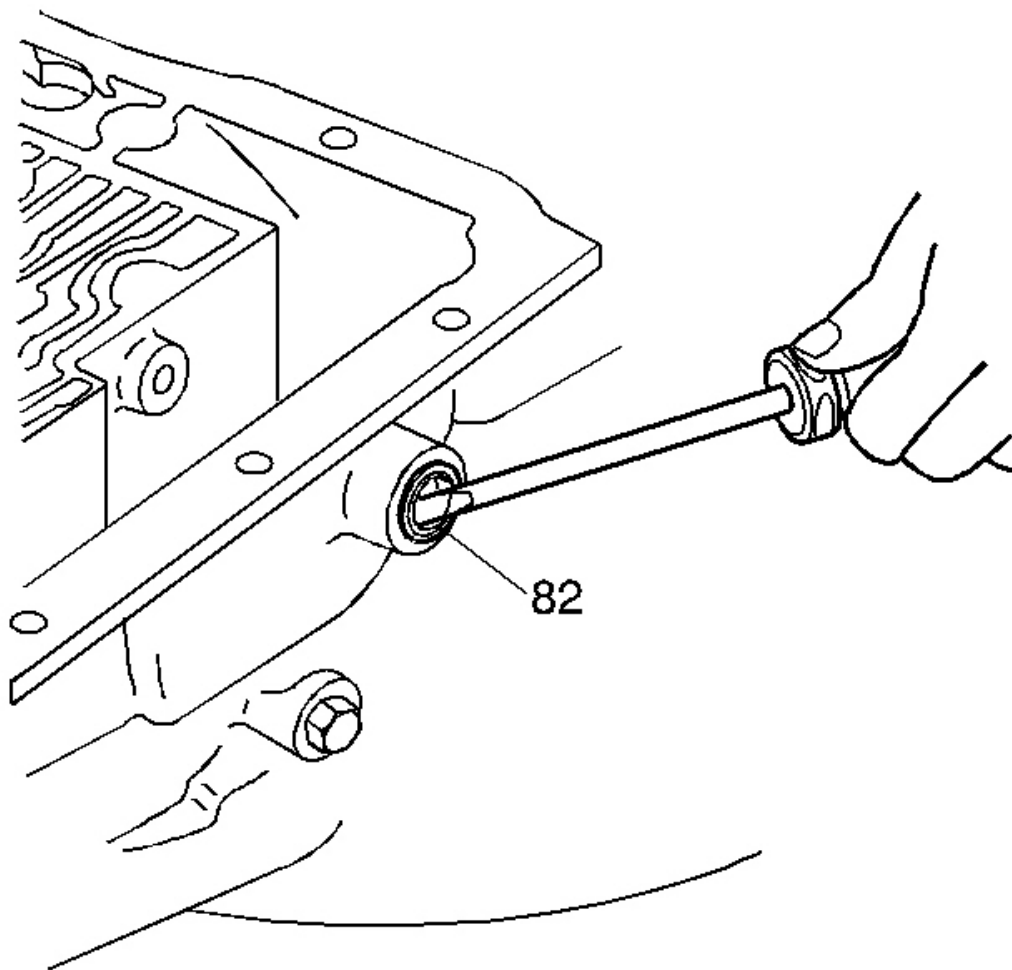

Fig. 243: Removing Manual Shaft Seal
Courtesy of GENERAL MOTORS CORP.

2. Remove the manual shaft seal (82) with a screwdriver.

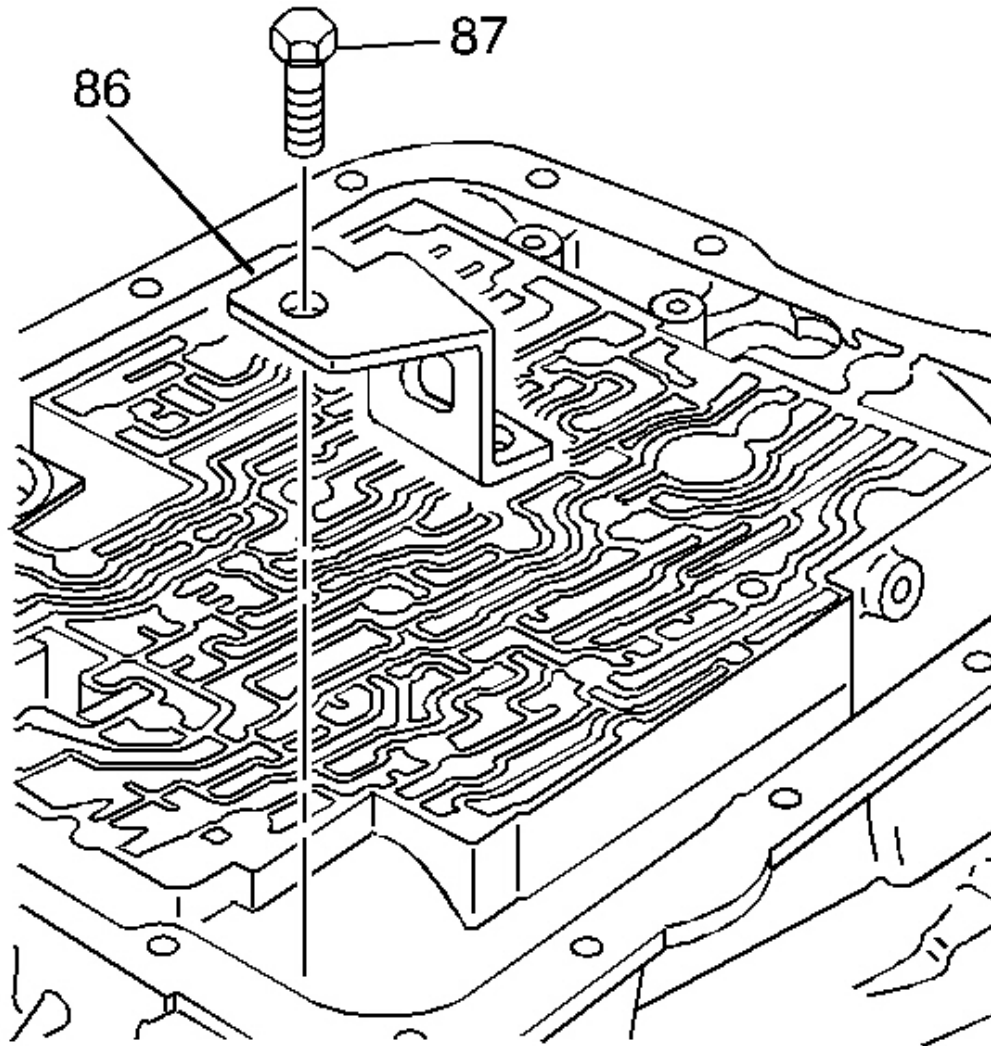

Fig. 244: View Of Parking Lock Bracket & Bolt
Courtesy of GENERAL MOTORS CORP.

3. Remove the following components:
 1. The parking lock bracket bolt (87)
 2. The parking lock bracket (86)

2007 Hummer H3

2007 TRANSMISSION Automatic Transmission - 4L60-E/4L65-E/4L70-E - H3

Tools Required

- **J 23327-1** Forward Clutch Spring Compressor (Bridge). See **Special Tools**.
- **J 34627** Snap Ring Remover and Installer. See **Special Tools**.
- **J-42628** Plate. See **Special Tools**.

Removal Procedure

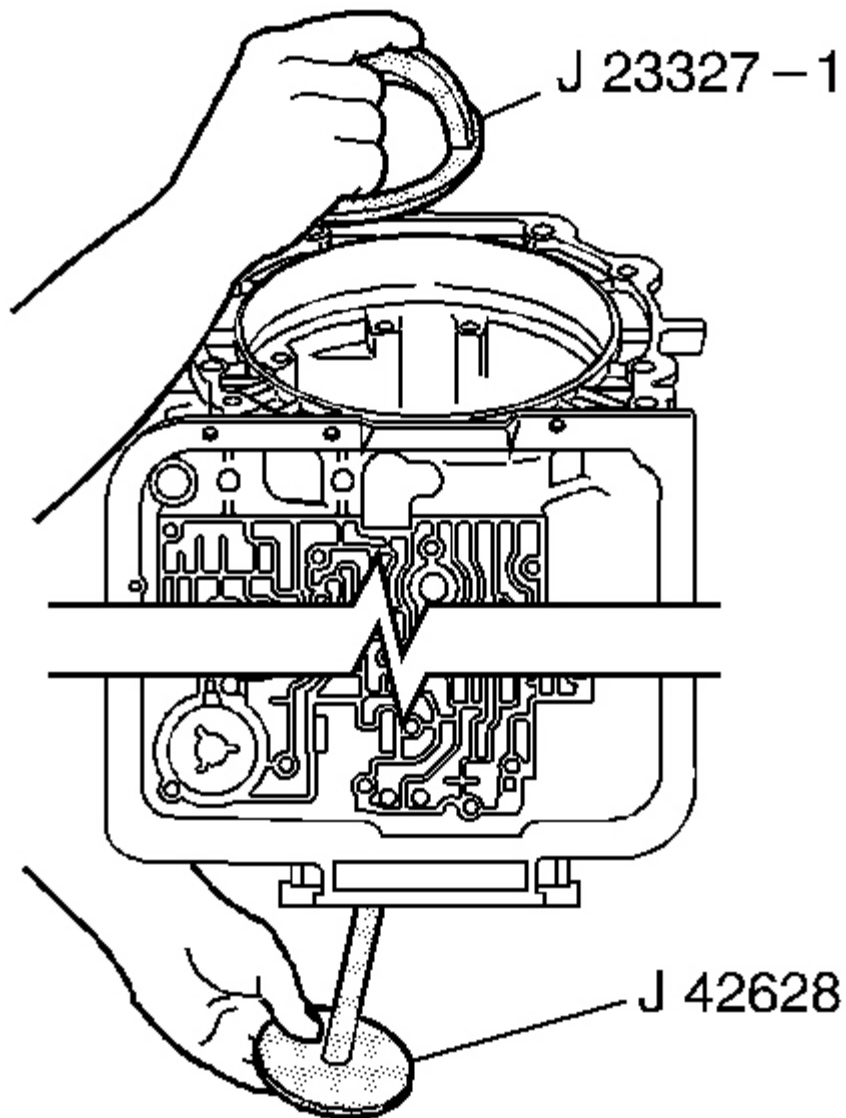
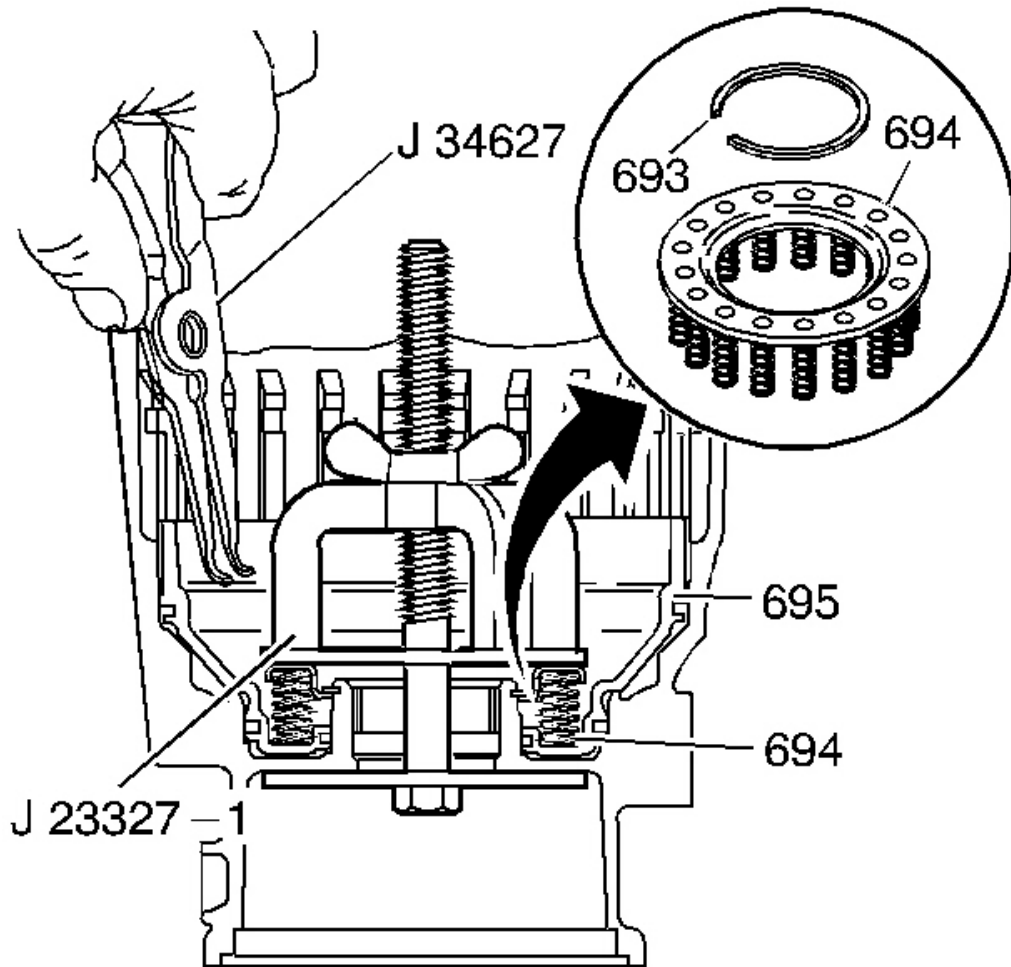

Fig. 245: Installing J 23327-1 & J 42628
Courtesy of GENERAL MOTORS CORP.

1. Install the **J 23327-1** and the **J-42628** . See Special Tools.



**Fig. 246: View Of Low And Reverse Clutch Spring Assembly & Retainer Ring
Courtesy of GENERAL MOTORS CORP.**

2. Tighten the **J 23327-1** . See **Special Tools**.
3. Remove the low and reverse clutch retainer ring (693) using the **J 34627** . See **Special Tools**.
4. Remove the low and reverse clutch spring assembly (694).

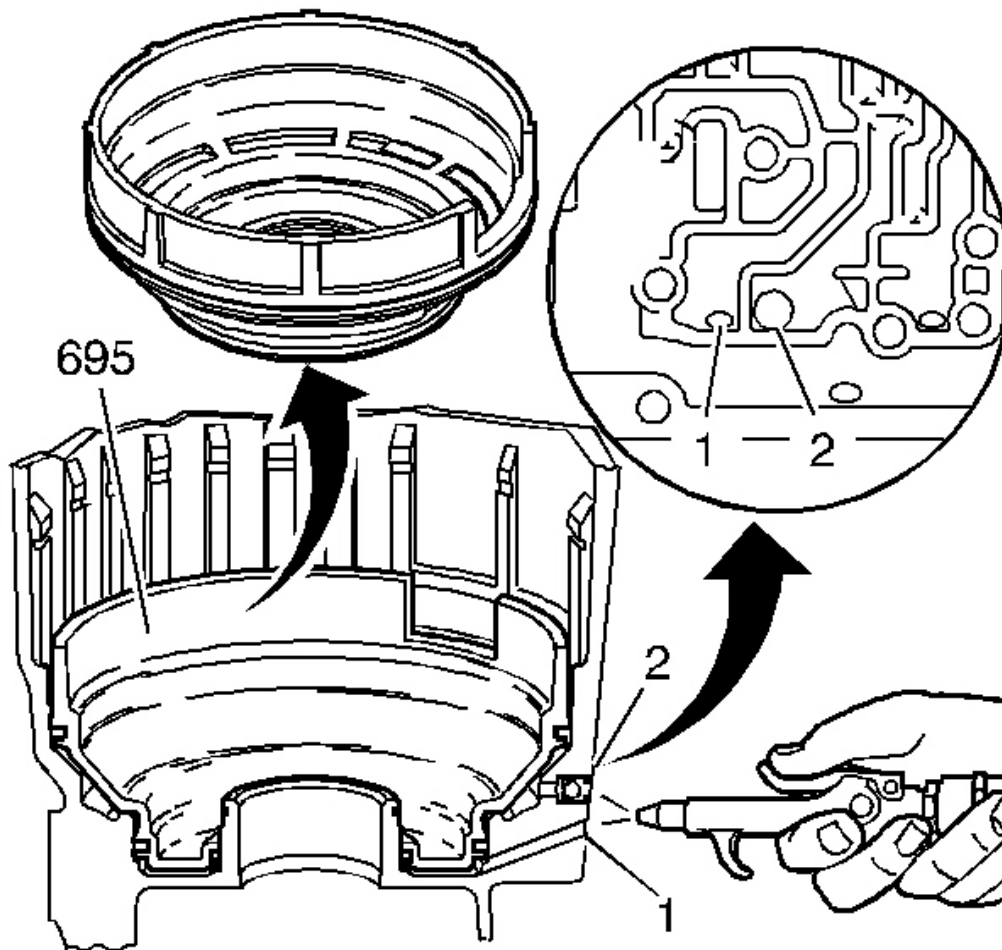

Fig. 247: Blowing Air Into Case Passage
Courtesy of GENERAL MOTORS CORP.

5. Blow compressed air into the case passage to remove the low and reverse clutch piston (695).
 - (1) LO Feed Passage
 - (2) REV Feed Passage

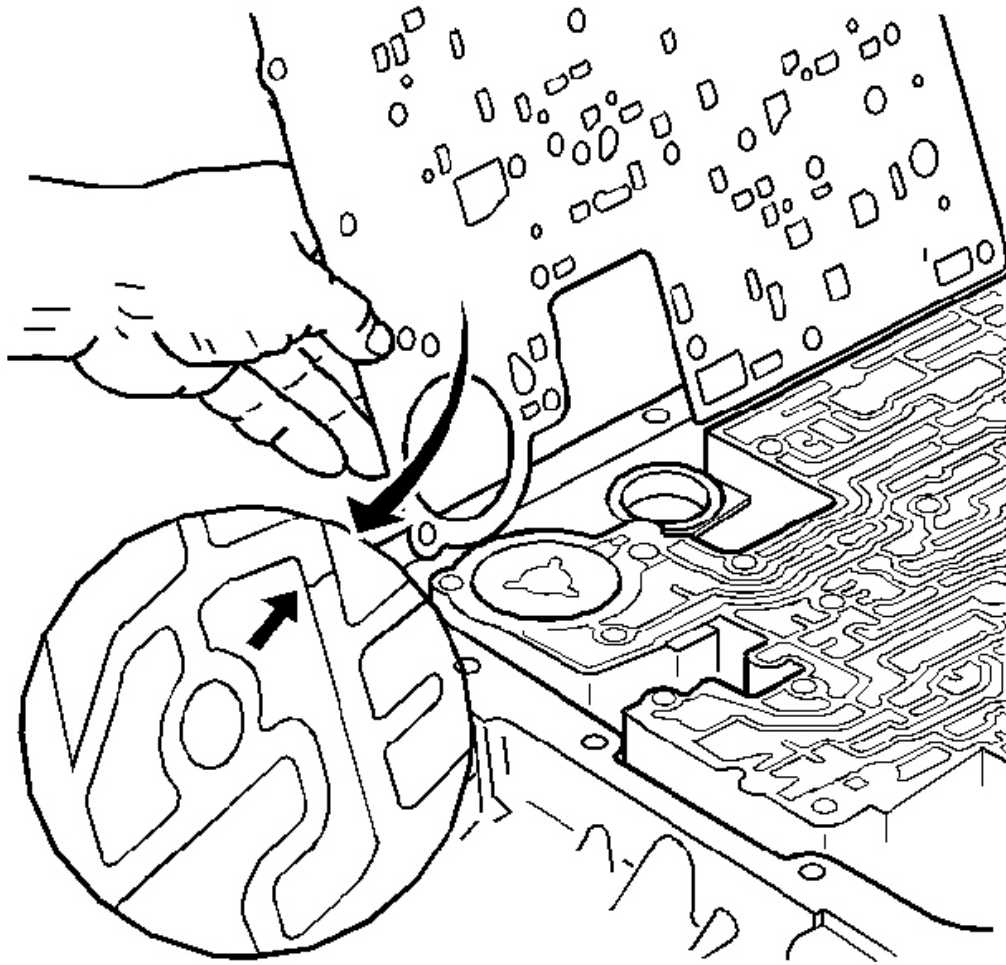

Fig. 248: Inspecting Spacer Plate To Case Gasket For Witness Marks
Courtesy of GENERAL MOTORS CORP.

1. Inspect the spacer plate to case gasket for witness marks. The witness marks should be complete. Incomplete witness marks may come from an uneven case surface or from cross channel leaks.

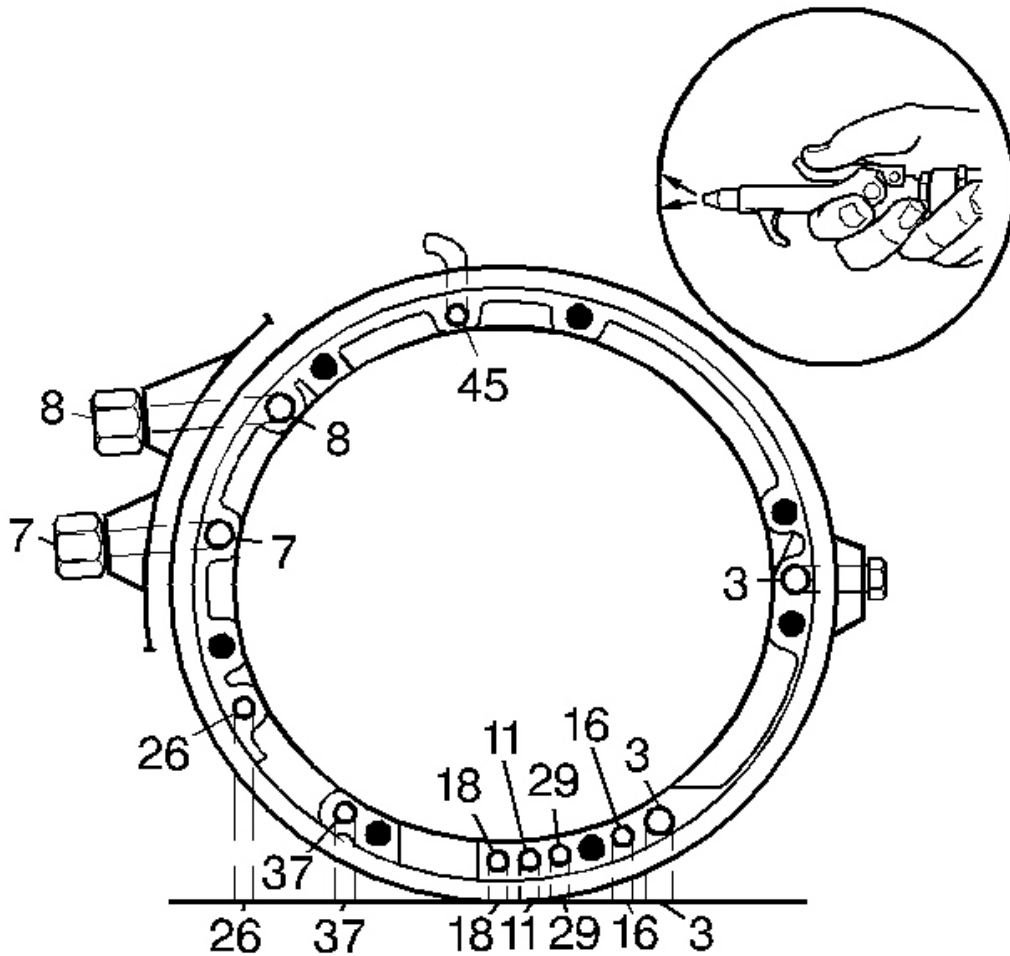

Fig. 249: Identifying Case Fluid Passages
 Courtesy of GENERAL MOTORS CORP.

- Using compressed air, blow into all of the case fluid passages (3, 7, 8, 11, 16, 18, 26, 29, 37, 45) to ensure that all case fluid passages are clear of any obstruction.

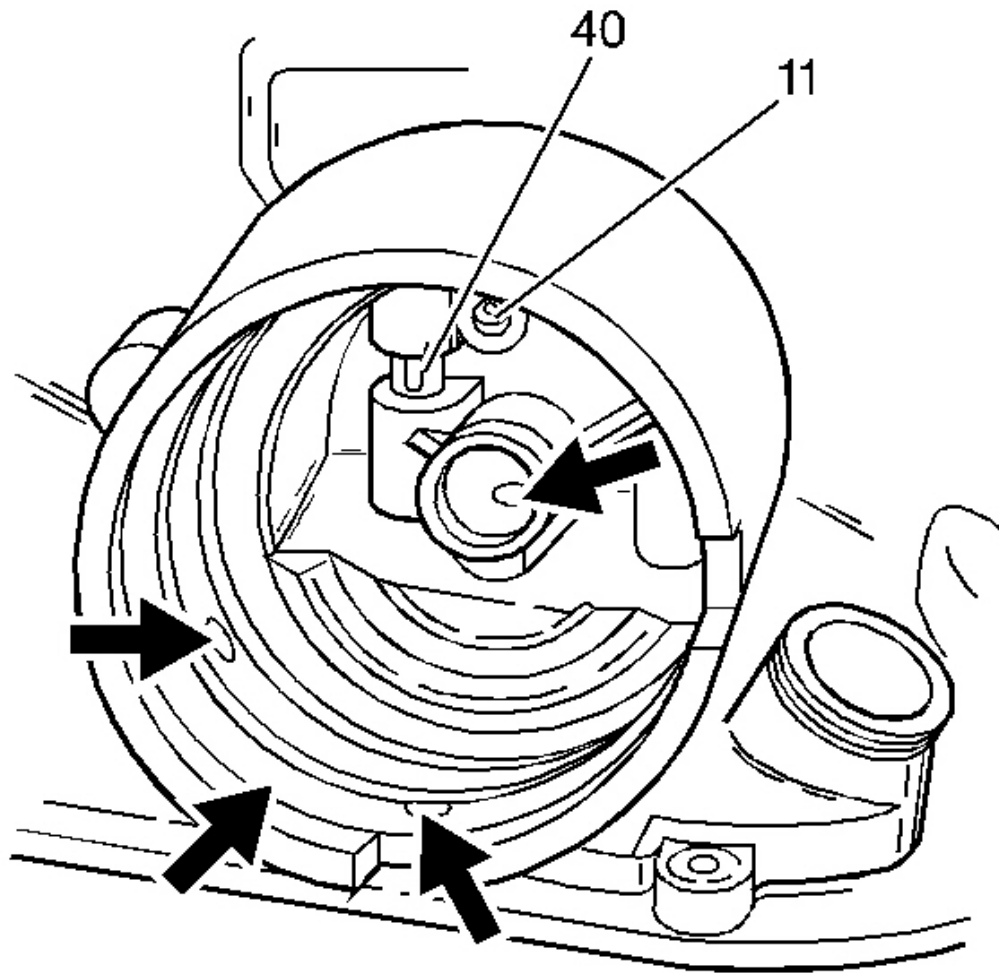

Fig. 250: Inspecting Case Assembly Components For Damage
Courtesy of GENERAL MOTORS CORP.

3. Inspect the 2-4 servo bore, the 3rd accumulator retainer and ball assembly (40), the orifice cup plug (11) in the servo bore and the 2nd apply piston pin bore for any of the following conditions:
 - Porosity
 - Burrs
 - Debris
 - Any other damage

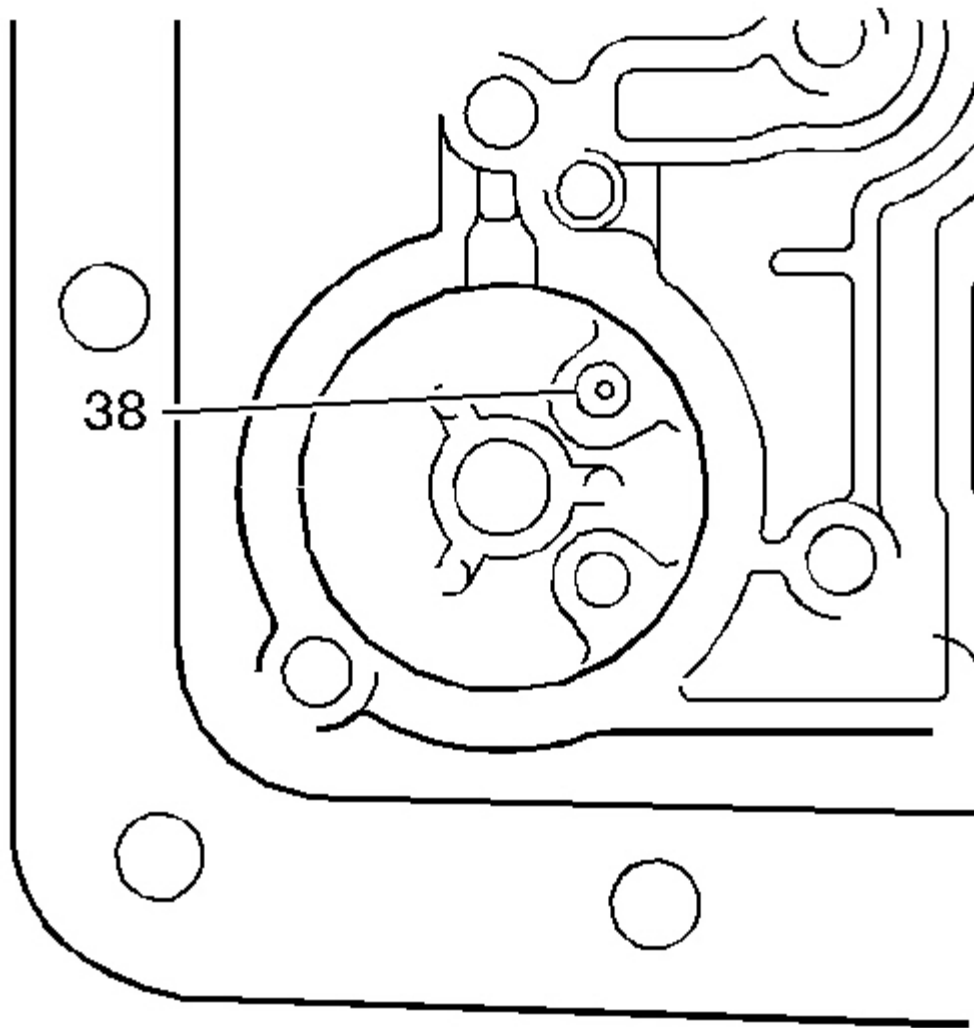

Fig. 251: Locating Orifice Cup Plug
Courtesy of GENERAL MOTORS CORP.

4. Inspect the 3-4 accumulator bore and the orifice cup plug (38) for any of the following conditions:
 - Porosity
 - Burrs
 - Blockage

2007 Hummer H3

2007 TRANSMISSION Automatic Transmission - 4L60-E/4L65-E/4L70-E - H3

- Any other damage
5. Inspect all bolt holes for thread damage. Use heli-coil to repair damaged threads.
 6. Inspect the cooler connectors for damage and proper torque.

Specification: Cooler connector torque should be 38 N.m (28 lb ft)

3RD ACCUMULATOR RETAINER WITH BALL ASSEMBLY LEAK CHECK

Tools Required

J 29714-A Servo Cover Depressor. See **Special Tools**.

Procedure

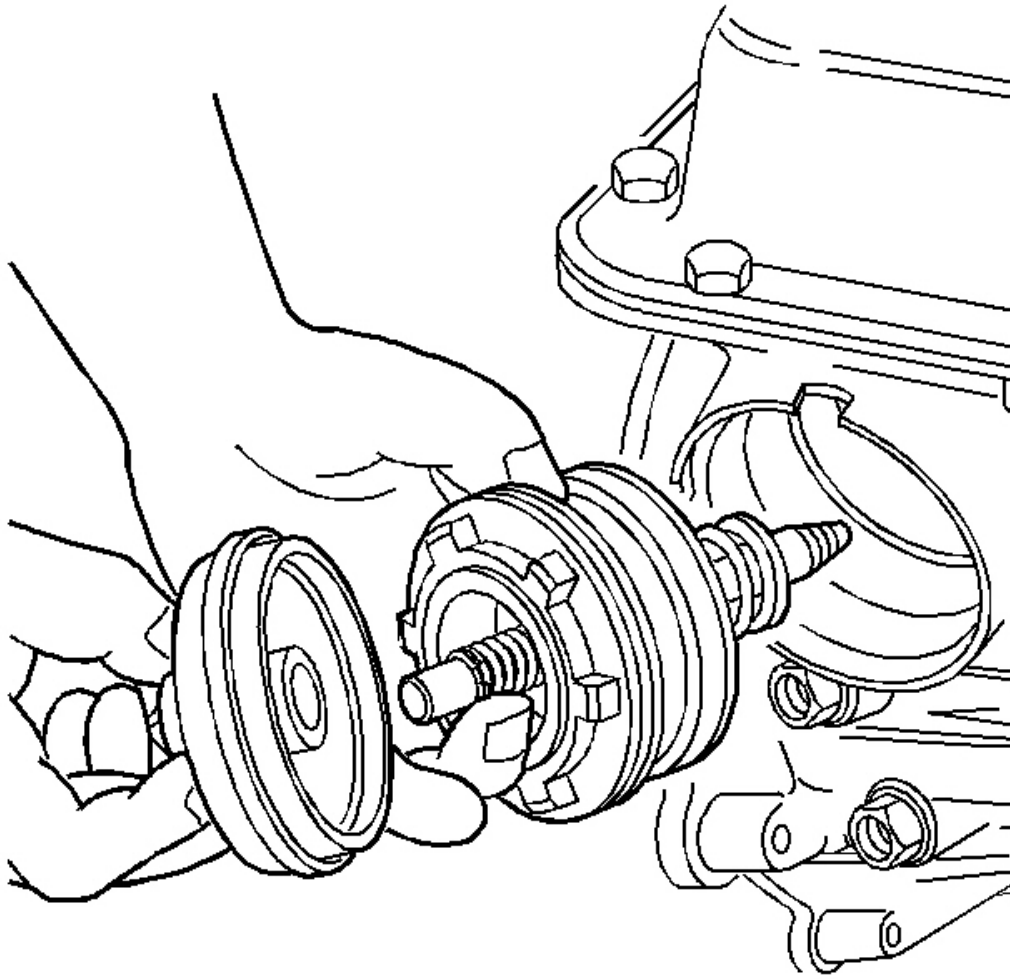

Fig. 252: View Of 2-4 Servo
Courtesy of GENERAL MOTORS CORP.

1. Install the 2-4 servo into the case.

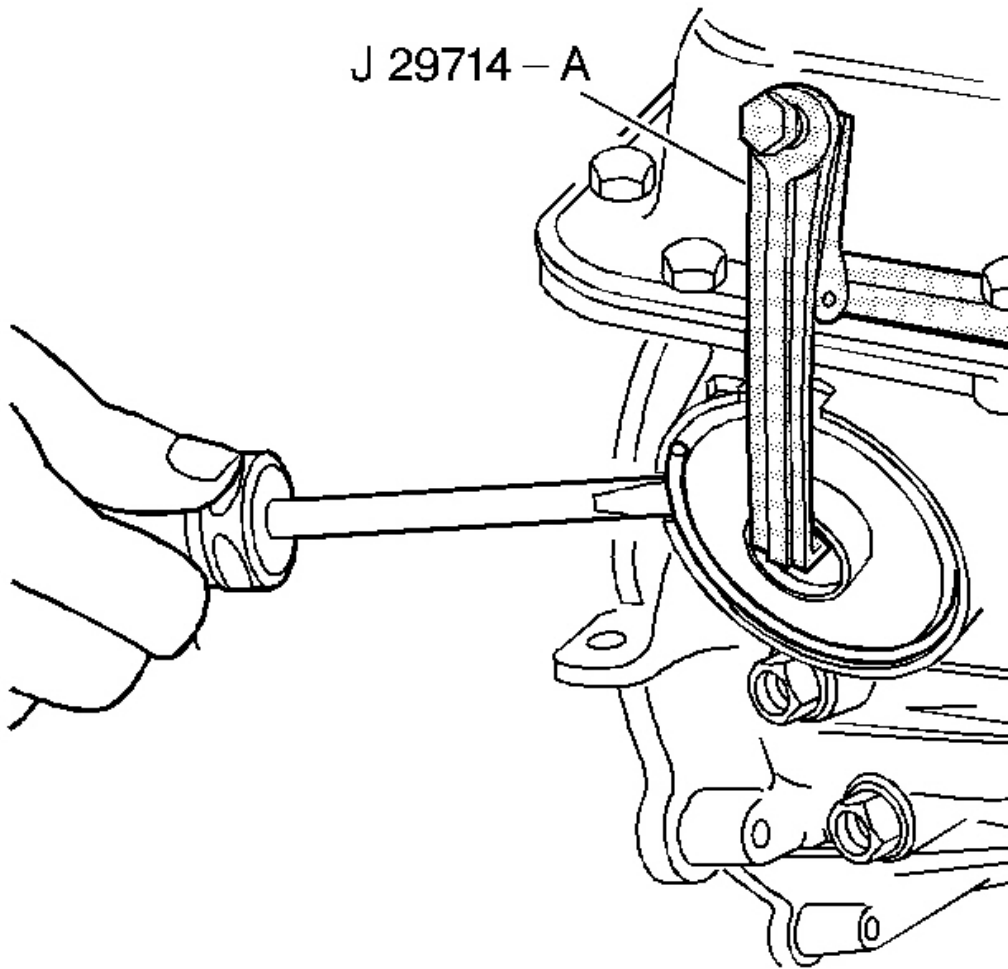

Fig. 253: Identifying J 29714-A
Courtesy of GENERAL MOTORS CORP.

2. Install oil pan with only four bolts to align pan to case.
3. Use the **J 29714-A** in order to compress the servo cover. See **Special Tools**.
4. Install the servo cover retaining ring.

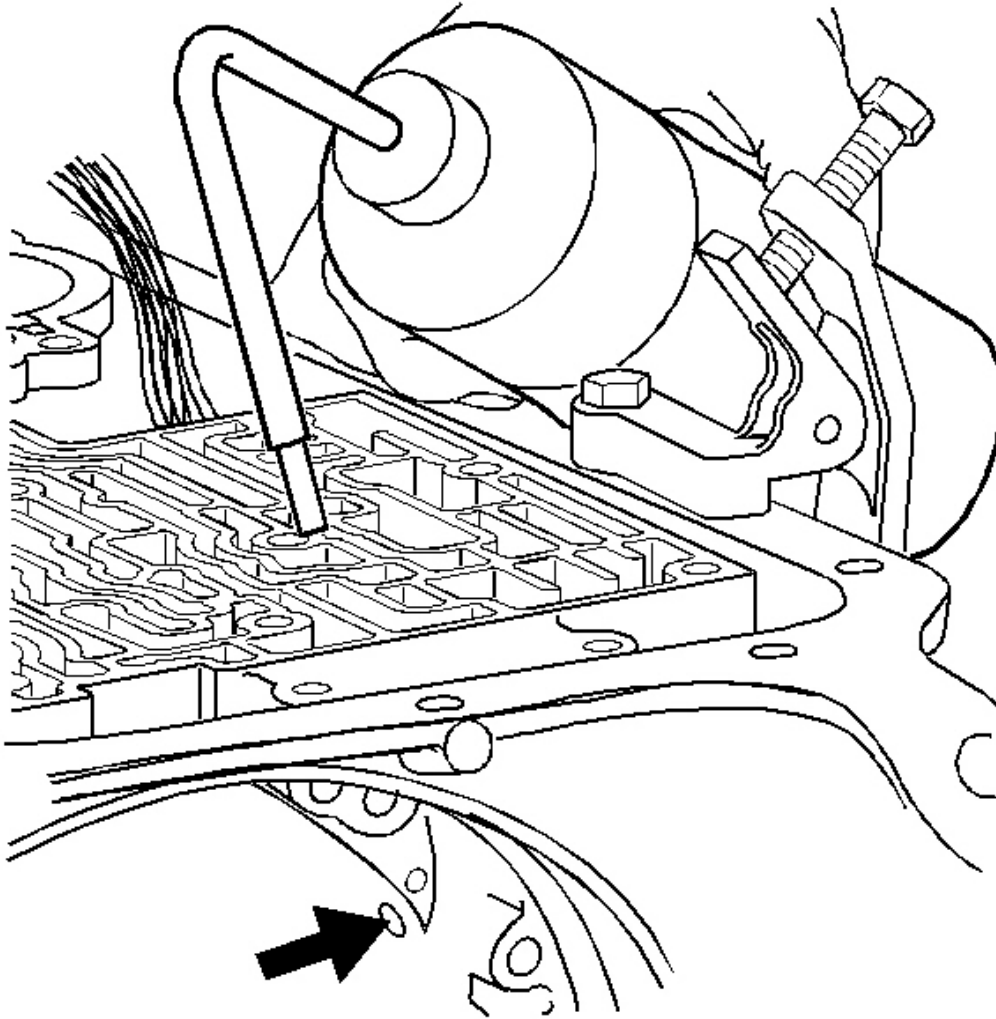

Fig. 254: Locating Small Hole In Accumulator
Courtesy of GENERAL MOTORS CORP.

5. Remove oil pan.
6. Pour solvent into the accumulator bore until the channel is filled. Watch for leaks in the case channel.

IMPORTANT: It is normal to see leakage from the small hole next to the larger oval hole.

7. If leakage from the oval shaped hole is observed, replace the third accumulator retainer and ball assembly.

3RD ACCUMULATOR RETAINER WITH BALL REPLACEMENT

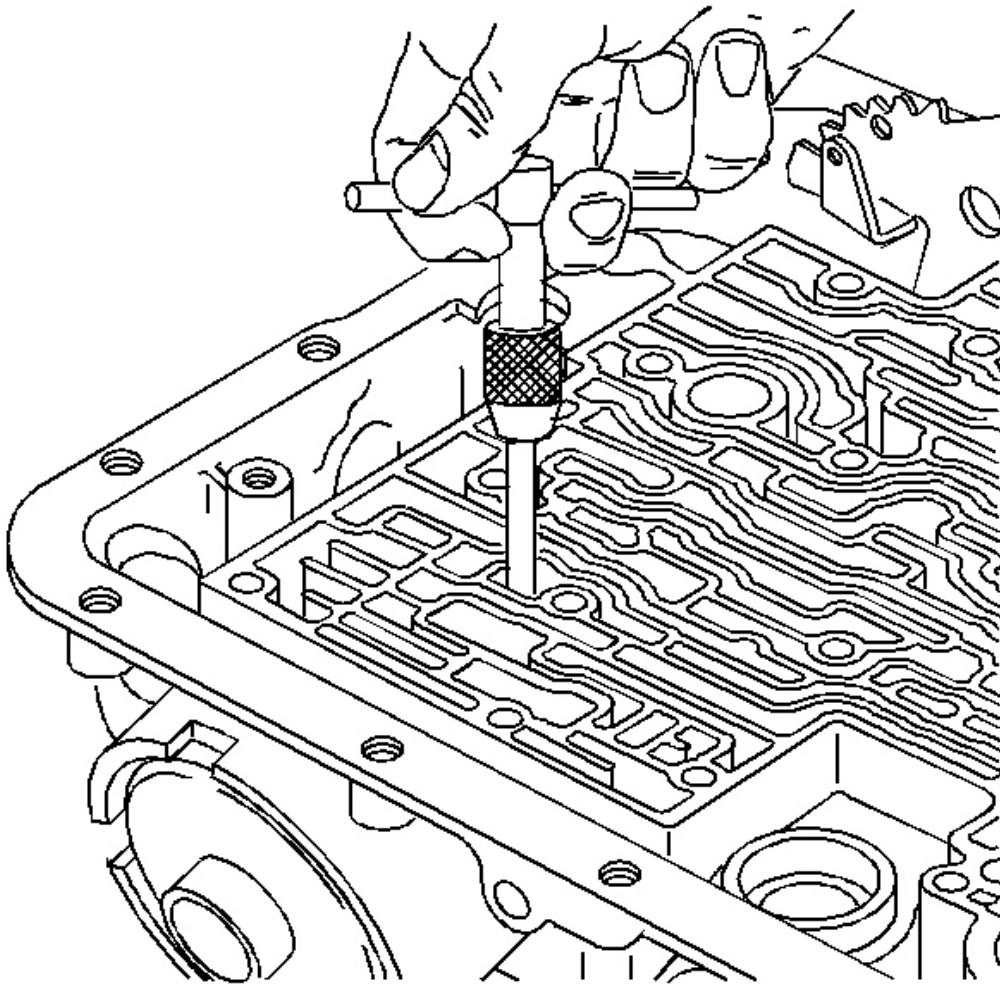

Fig. 255: Extracting Third Accumulator Retainer And Ball Assembly
Courtesy of GENERAL MOTORS CORP.

1. Remove the third accumulator retainer and ball assembly, using a 6.3 mm (0.25 in) #4 screw extractor.

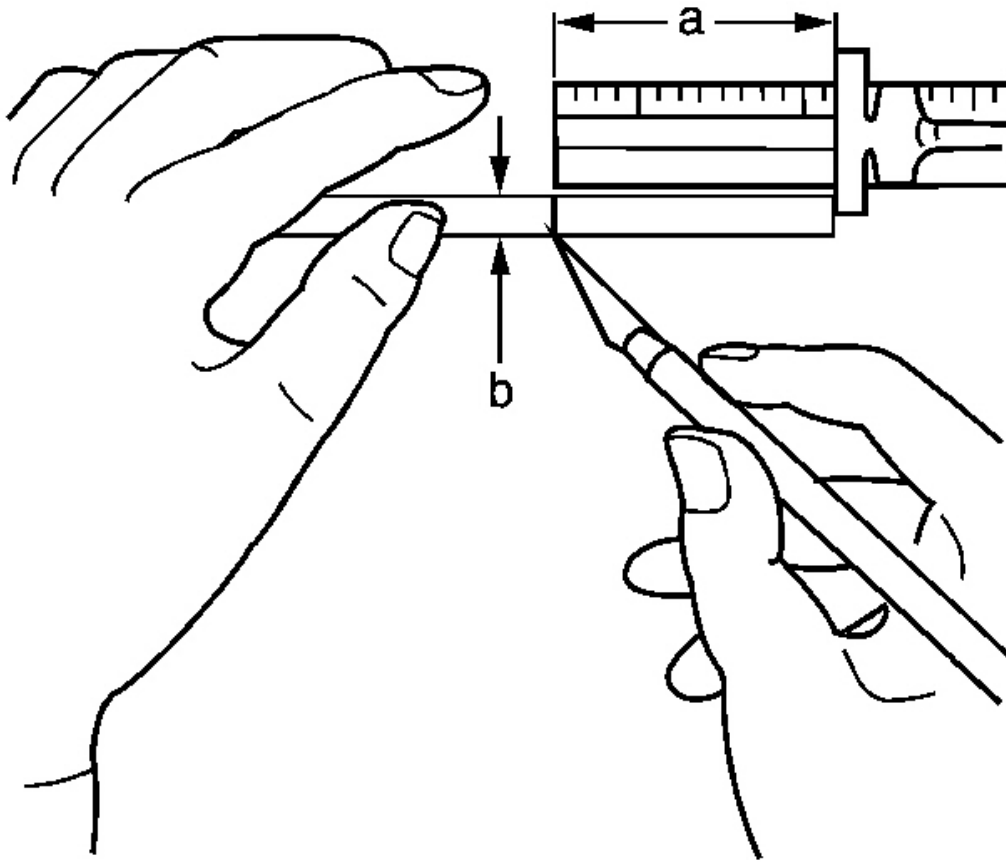

Fig. 256: Scribing Mark On Rod For Gaging Proper Depth Of Third Accumulator Retainer And Ball Assembly

Courtesy of GENERAL MOTORS CORP.

2. Scribe a mark at 42 mm (1.653 in) on a 9.5 mm (0.375 in) diameter metal rod. The scribe mark is used to gage the proper depth of the third accumulator retainer and ball assembly.

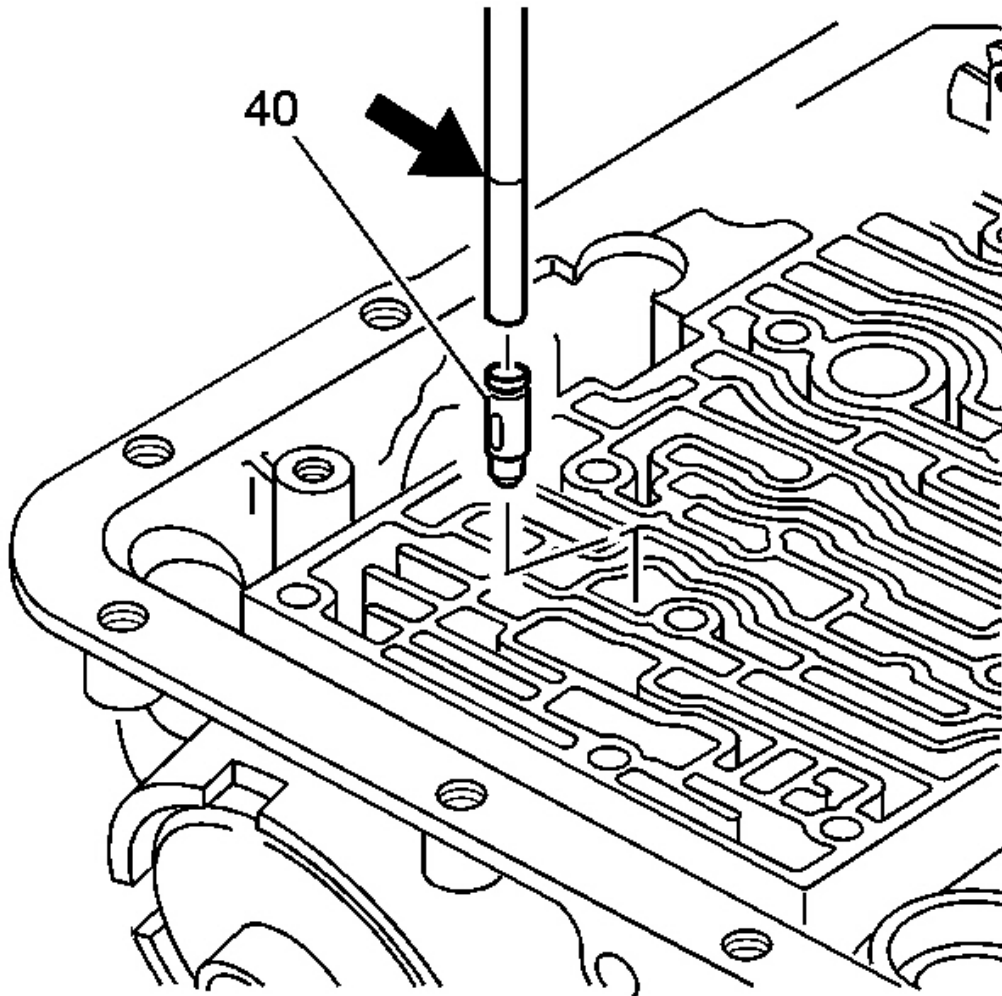

Fig. 257: Installing Third Accumulator Retainer And Ball Assembly
Courtesy of GENERAL MOTORS CORP.

3. Perform the following functions:
 1. Line up the oil feed slots in the third accumulator retainer and ball assembly (40) with the servo bore.
 2. Using the 9.5 mm (0.375 in) diameter metal rod, install the third accumulator retainer and ball assembly.

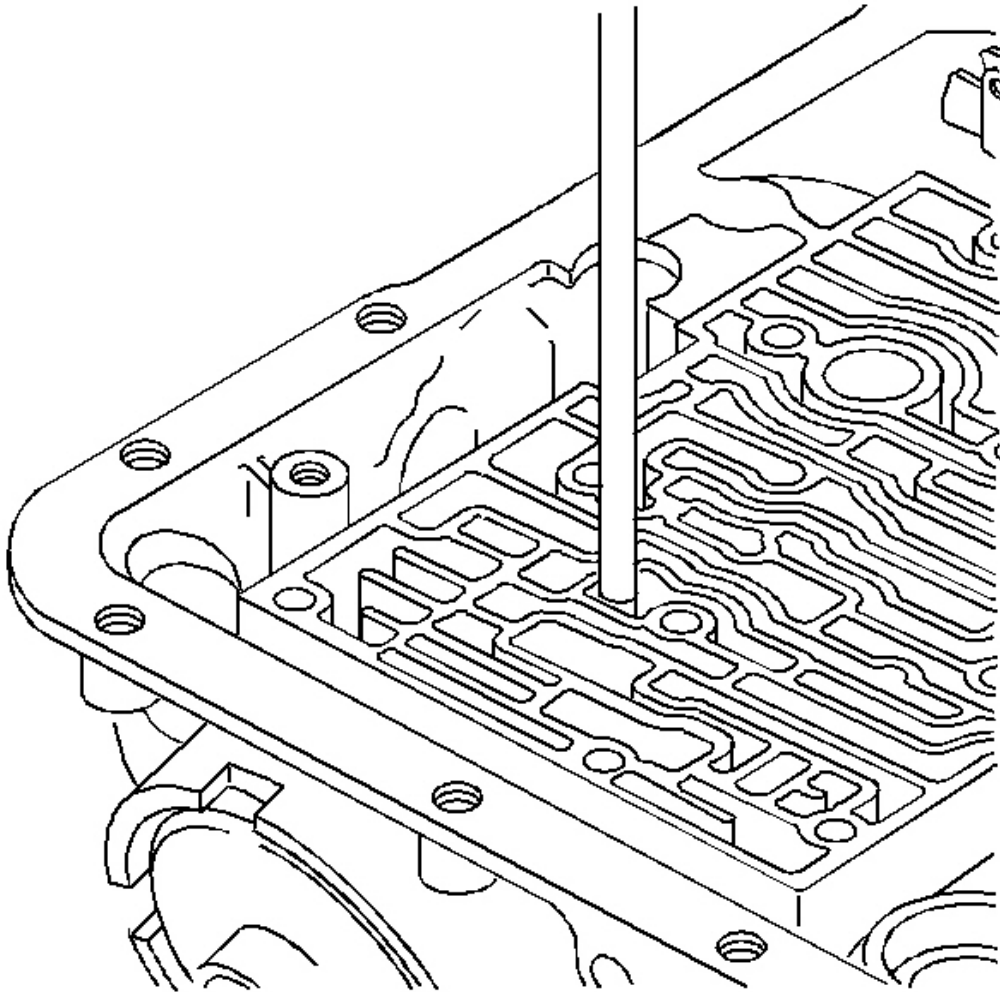

Fig. 258: Checking Third Accumulator Retainer And Ball Assembly Alignment
Courtesy of GENERAL MOTORS CORP.

4. Ensure that the third accumulator retainer and ball assembly and the scribe mark on the rod are flush with the case surface.

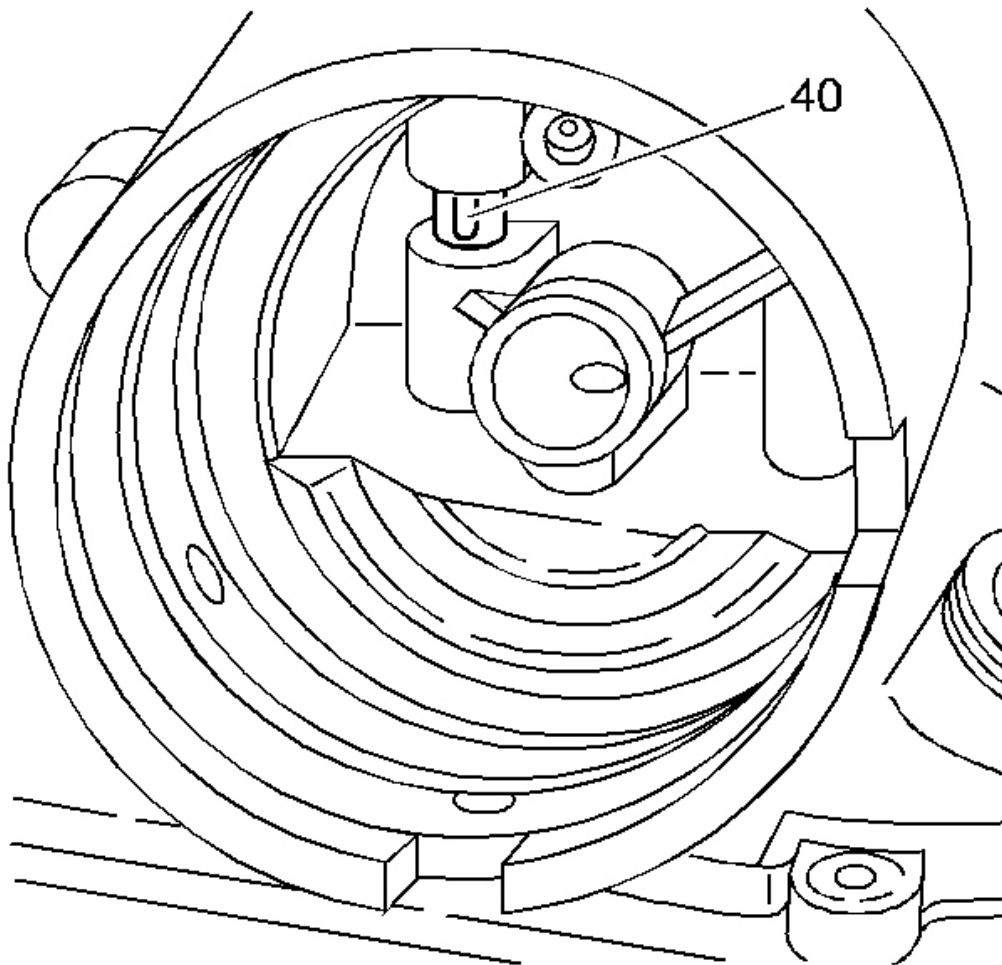

Fig. 259: Aligning Third Accumulator Retainer And Ball Assembly With Retainer Slot

Courtesy of GENERAL MOTORS CORP.

5. Check the third accumulator retainer and ball assembly (40) for alignment. The slot in the retainer must be completely open in the servo bore.

CASE BUSHING

Tools Required

- **J 8092 Driver Handle**

- **J 34196-B** Transmission Bushing Service Set. See **Special Tools**.

Removal Procedure

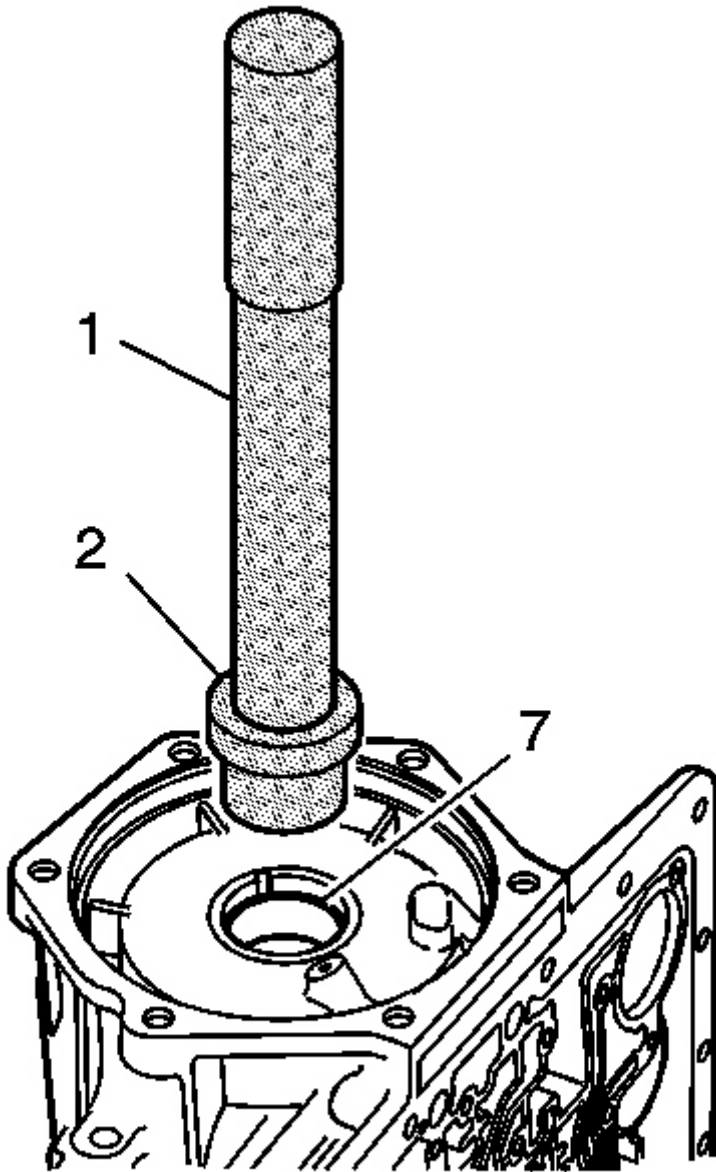

Fig. 260: View Of Case Bushing

Courtesy of GENERAL MOTORS CORP.

Remove the case bushing (7) using J 8092 (1) and J 34196-10 (2) which is part of kit J 34196-B . See Special Tools.

Installation Procedure

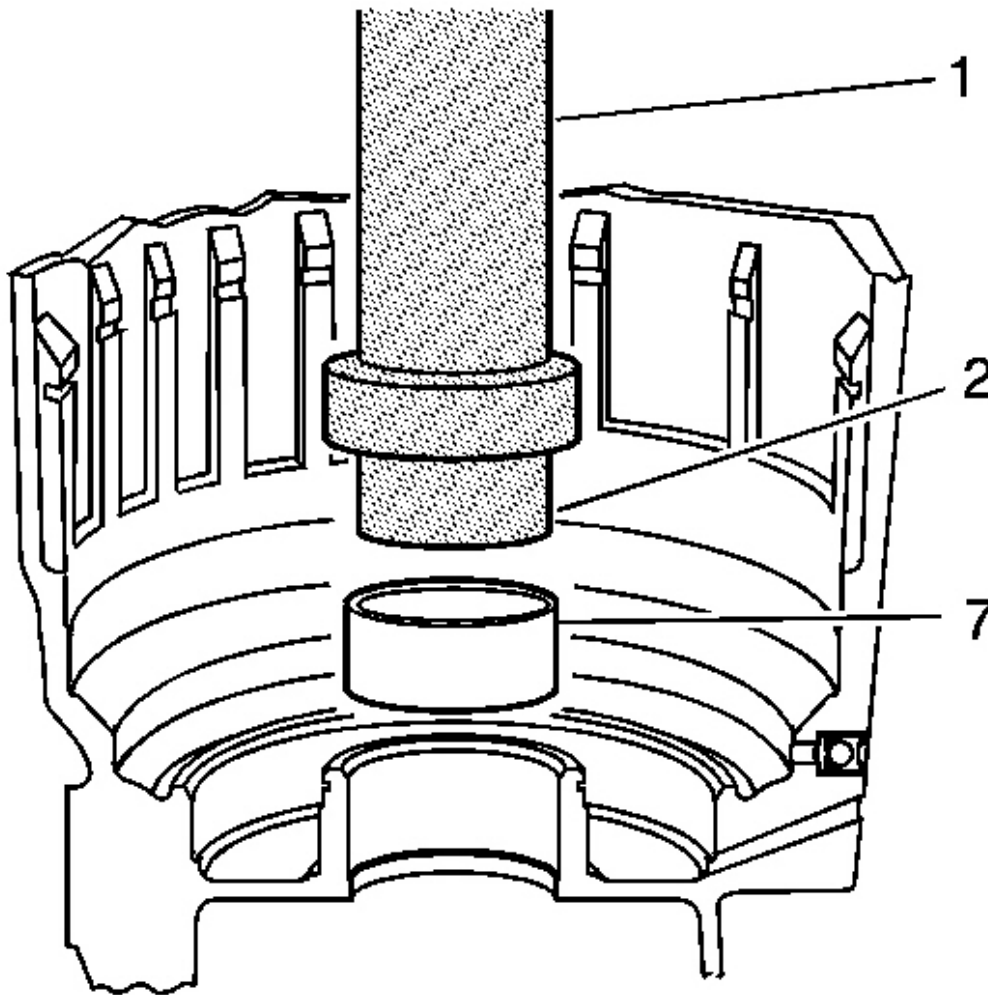

Fig. 261: Installing Case Bushing
Courtesy of GENERAL MOTORS CORP.

Install a case bushing (7) using **J 8092** (1) and J 34196-10 (2) which is part of kit **J 34196-B** .
See **Special Tools**.

MANUAL SHIFT SHAFT SEAL INSTALLATION

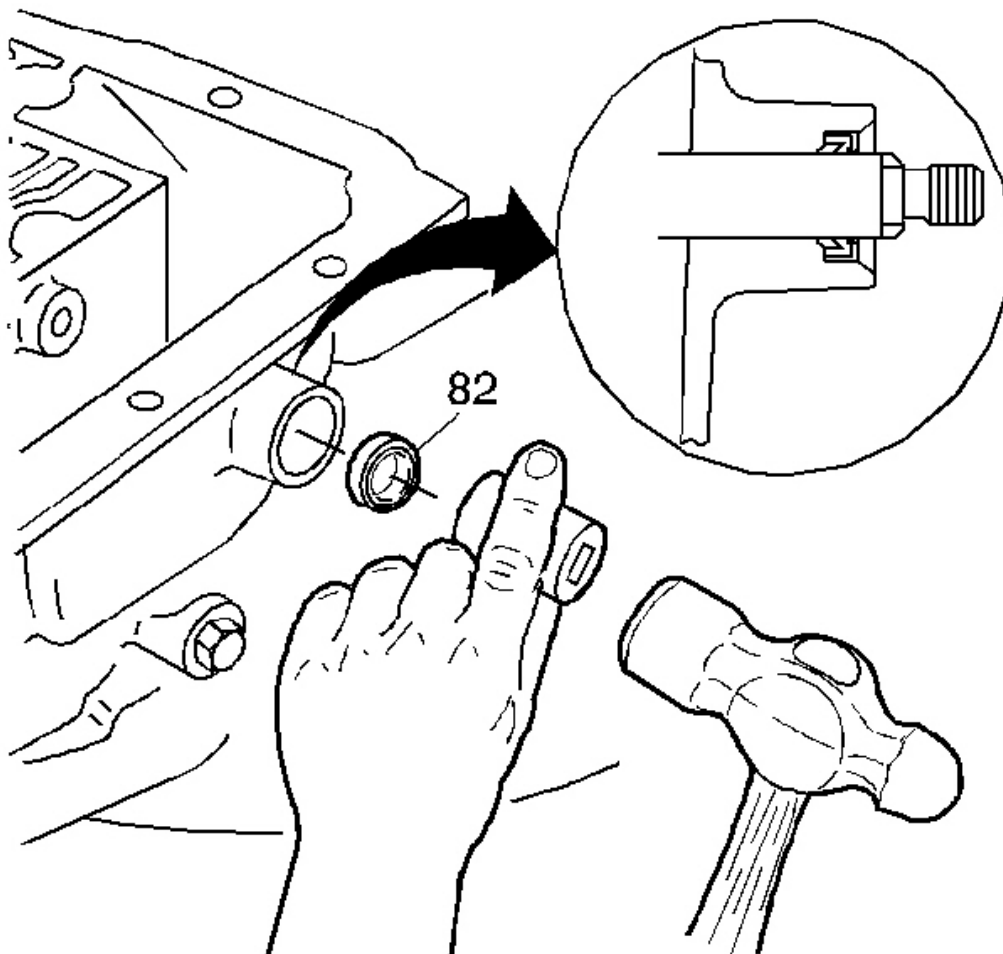

Fig. 262: Installing Manual Shaft Seal
Courtesy of **GENERAL MOTORS CORP.**

Install a new manual shaft seal (82).

LOW AND REVERSE CLUTCH PISTON INSTALLATION

2007 Hummer H3

2007 TRANSMISSION Automatic Transmission - 4L60-E/4L65-E/4L70-E - H3

Tools Required

- **J 23327-1** Forward Clutch Spring Compressor (Bridge). See **Special Tools**.
- **J 34627** Snap Ring Remover and Installer. See **Special Tools**.
- **J 36850** Transjel Lubricant

Installation Procedure

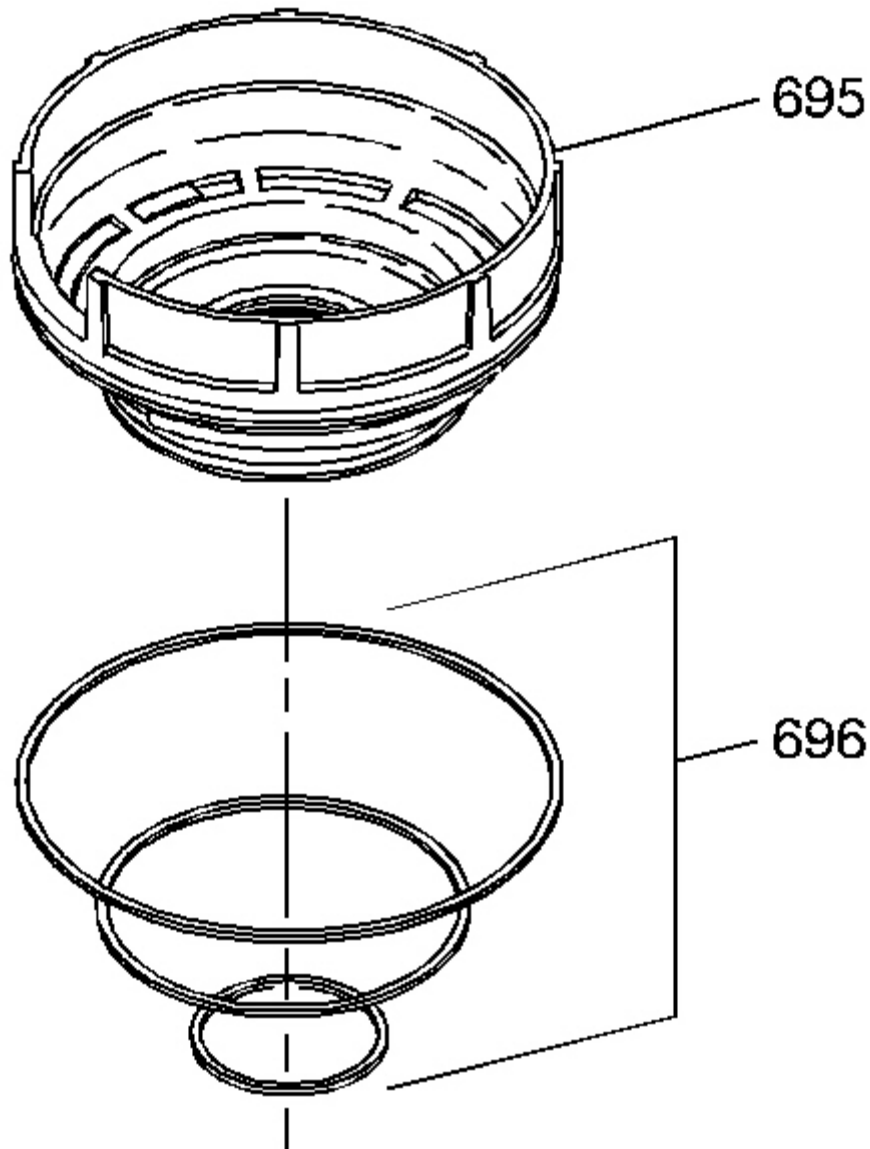

Fig. 263: Installing Transmission Seals Onto Low And Reverse Clutch Piston
Courtesy of GENERAL MOTORS CORP.

1. Install the transmission (low and reverse clutch outer, center, inner) seals (696) on the low and reverse clutch piston (695).

2. Lubricate the seals with assembly lubricant **J 36850** or an equivalent.

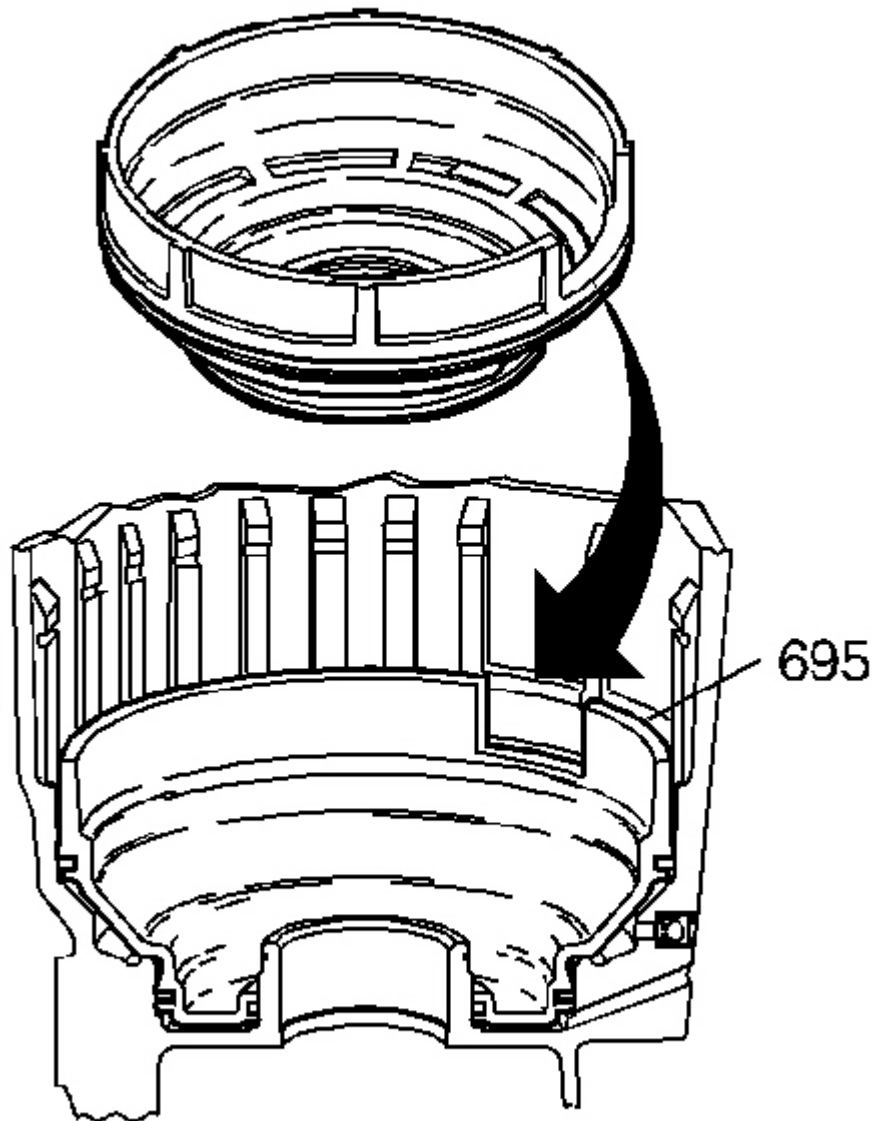

Fig. 264: Aligning Parking Brake Pawl Window With Notch In Piston
Courtesy of GENERAL MOTORS CORP.

3. Install the low and reverse clutch piston (695) into the case. The notch in the piston must be

aligned with the parking brake pawl window, in the case.

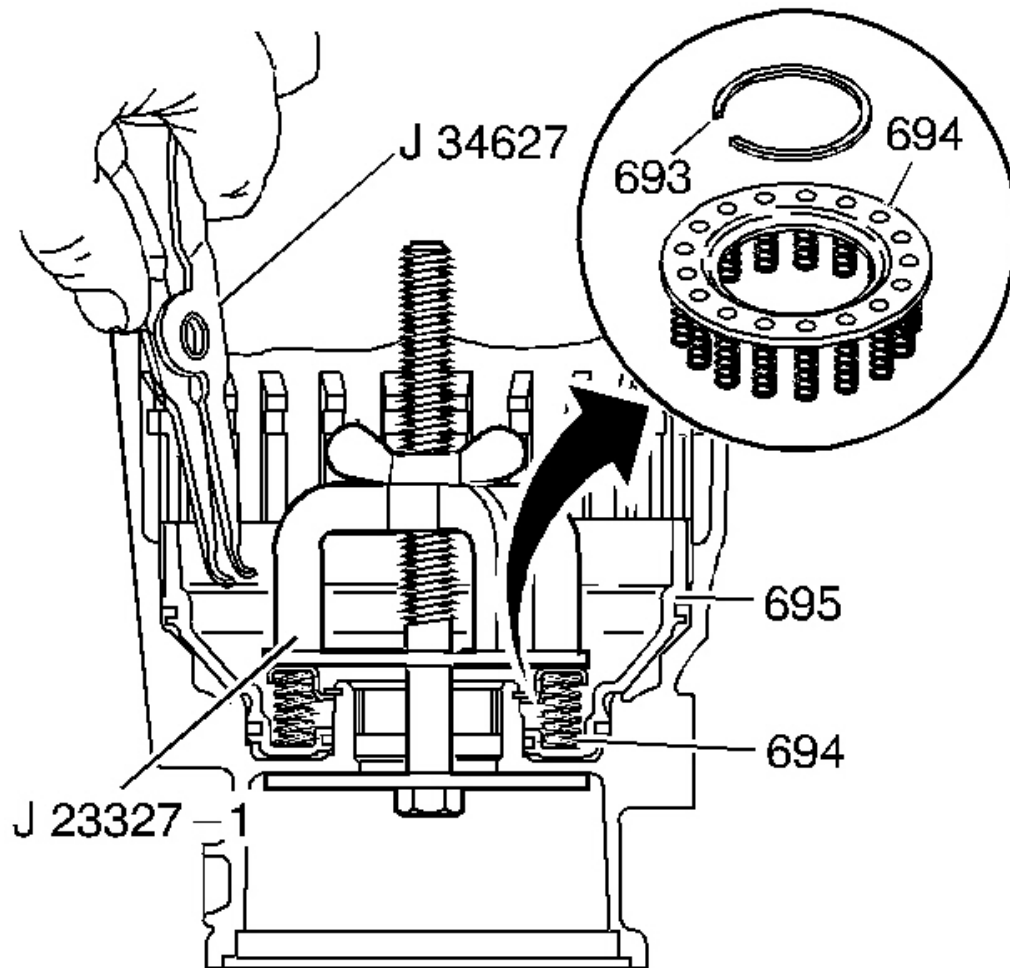

Fig. 265: View Of Low And Reverse Clutch Spring Assembly & Retainer Ring
 Courtesy of GENERAL MOTORS CORP.

4. Install the low and reverse clutch spring assembly (694).
 1. Using the **J 23327-1** , compress the low and reverse clutch spring assembly (694). See **Special Tools**.
 2. Using **J 36850** install the low and reverse clutch retainer ring (693).

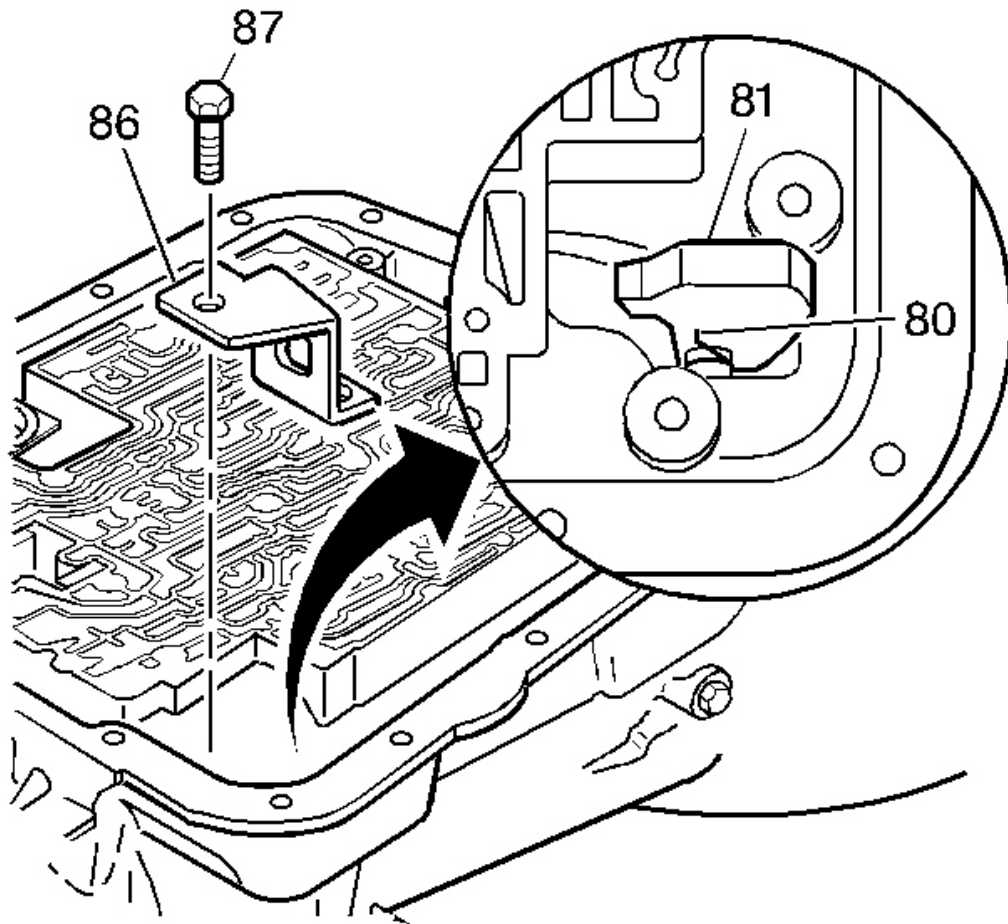

Fig. 266: Locating Parking Brake Pawl & Return Spring
Courtesy of GENERAL MOTORS CORP.

1. Install the parking lock bracket (86).

NOTE: Refer to Fastener Notice.

2. Install the parking lock bracket bolt (87).

Tighten: Tighten the bolt to 31 N.m (23 lb ft).

3. Inspect the following items:

- The parking brake pawl (81) for damage or cracks
- The parking pawl return spring (80) for being broken or missing

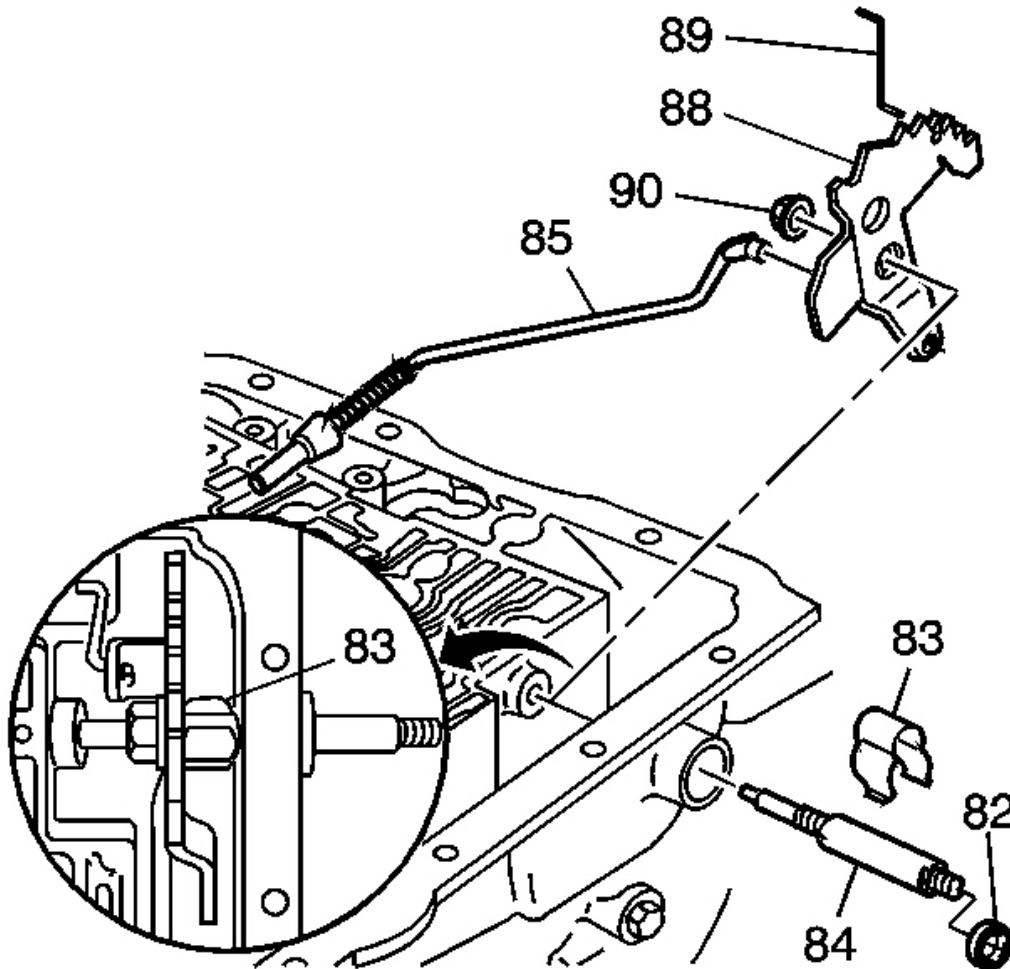

Fig. 267: View Of Manual Shaft, Parking Lock Actuator Assembly, Inside Detent Lever & Components
Courtesy of GENERAL MOTORS CORP.

4. Inspect the following items:
 - The manual shaft retainer (83) for damage or cracks
 - The manual shaft (84) for damage or burrs

2007 Hummer H3

2007 TRANSMISSION Automatic Transmission - 4L60-E/4L65-E/4L70-E - H3

- The parking lock actuator assembly (85) for damage
- The inside detent lever (88) for damage or cracks
- The manual valve link (89) for damage
- The hex head nut (90) for damage or stripped threads

5. Install the following items:

- The inside detent lever (88)
- The parking lock actuator assembly (85)
- The manual shaft (84) (model dependent)
- The manual shaft retainer (83)
- The hex head nut (90)
- The manual valve link (89)

Tighten: Tighten the nut to 31 N.m (23 lb ft).

REACTION GEAR AND CARRIER INSPECTION

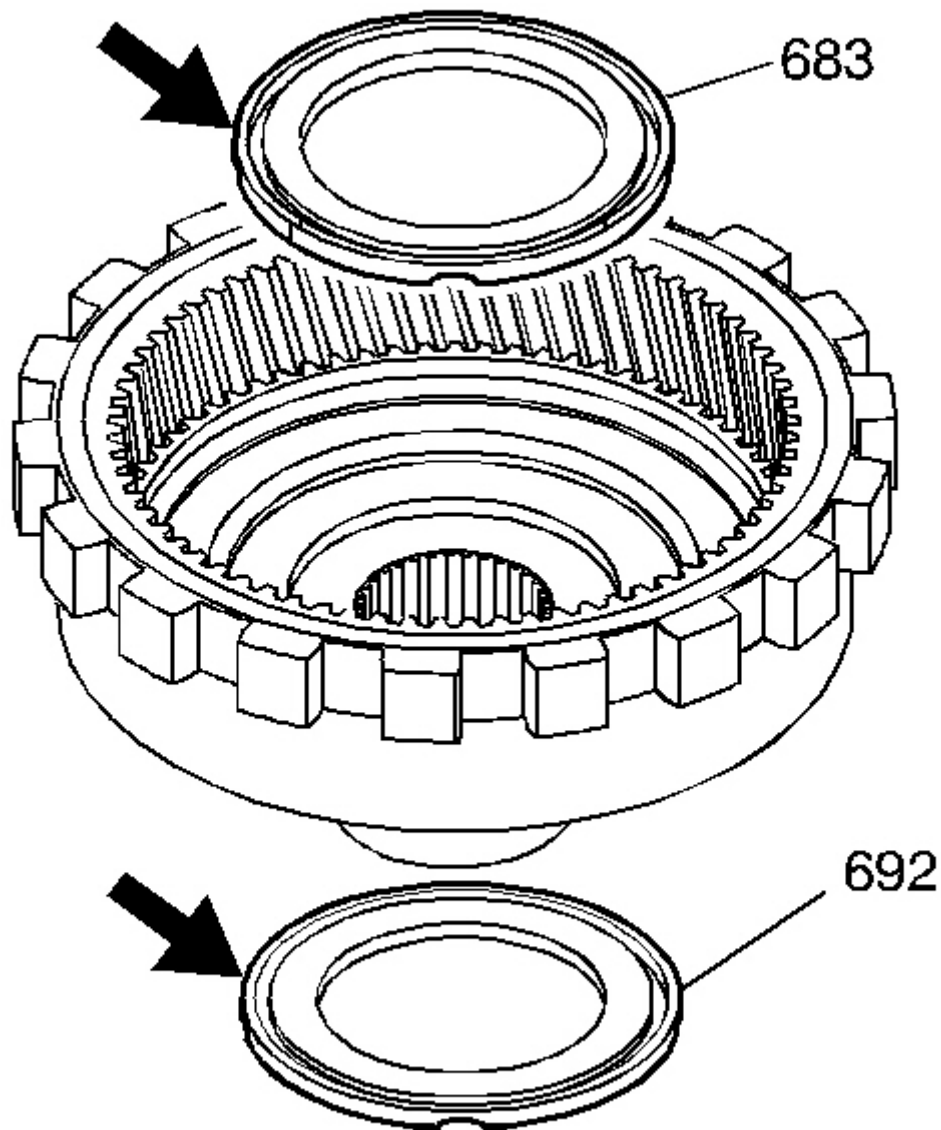

Fig. 268: Inspecting Areas Of Reaction Carrier/Support Thrust Bearing Assembly
Courtesy of GENERAL MOTORS CORP.

1. Inspect the reaction carrier/support thrust bearing assembly (683) for wear or damage.
2. Inspect the reaction gear support to case bearing (692) for wear or damage.

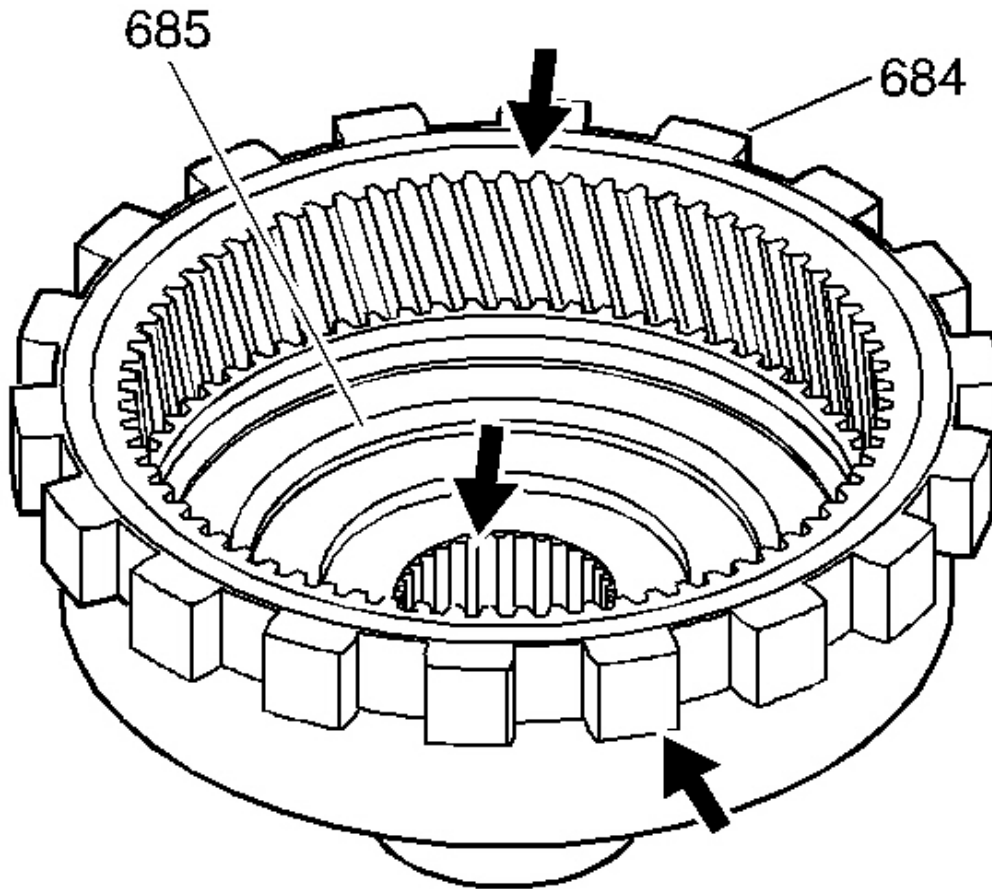

Fig. 269: View Of Reaction Gear And Carrier Inspection Areas
Courtesy of GENERAL MOTORS CORP.

3. Inspect the internal reaction gear (684) and the internal reaction gear support (685) for proper assembly, stripped splines, cracks, teeth and lug damage.

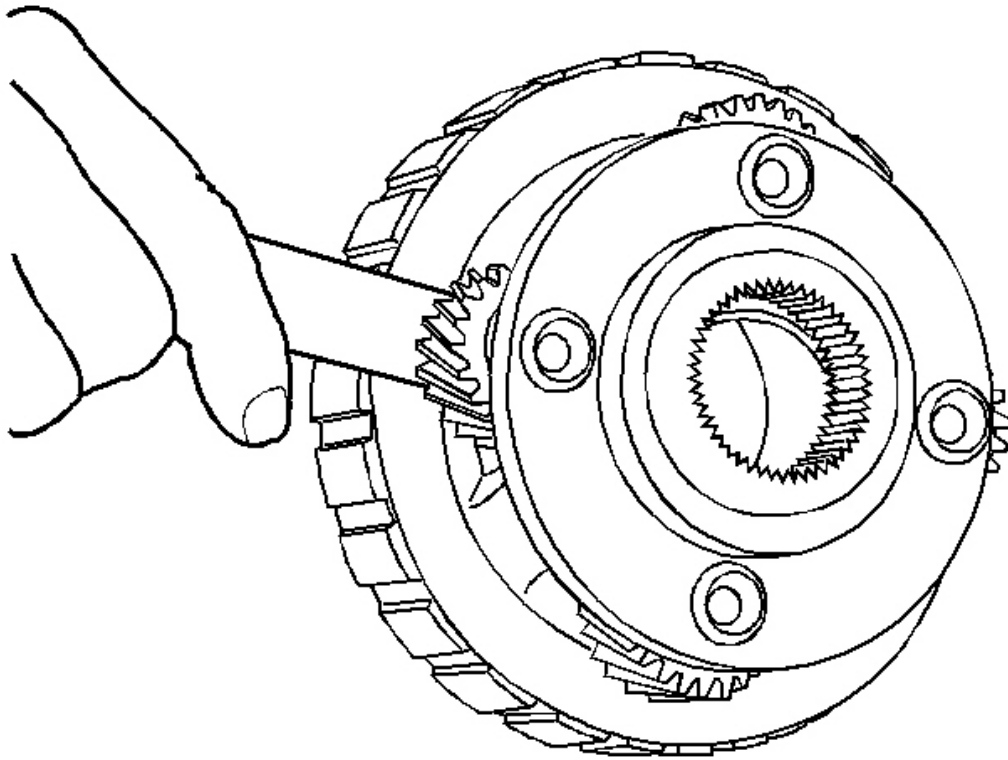

Fig. 270: Checking Reaction Carrier Pinion End Play With Feeler Gage
Courtesy of GENERAL MOTORS CORP.

IMPORTANT: Inspect all pinions, either 4 or 5 depending on model.

4. Check the reaction carrier pinion end play. The end play must not exceed 0.61 mm (0.024 in).

Inspect the reaction carrier for the following conditions:

- Pinion gear damage
 - Proper pinion staking
 - Excessive pinion washer wear
 - Keystoned pinion gears
5. Ensure that the pinions turn freely.

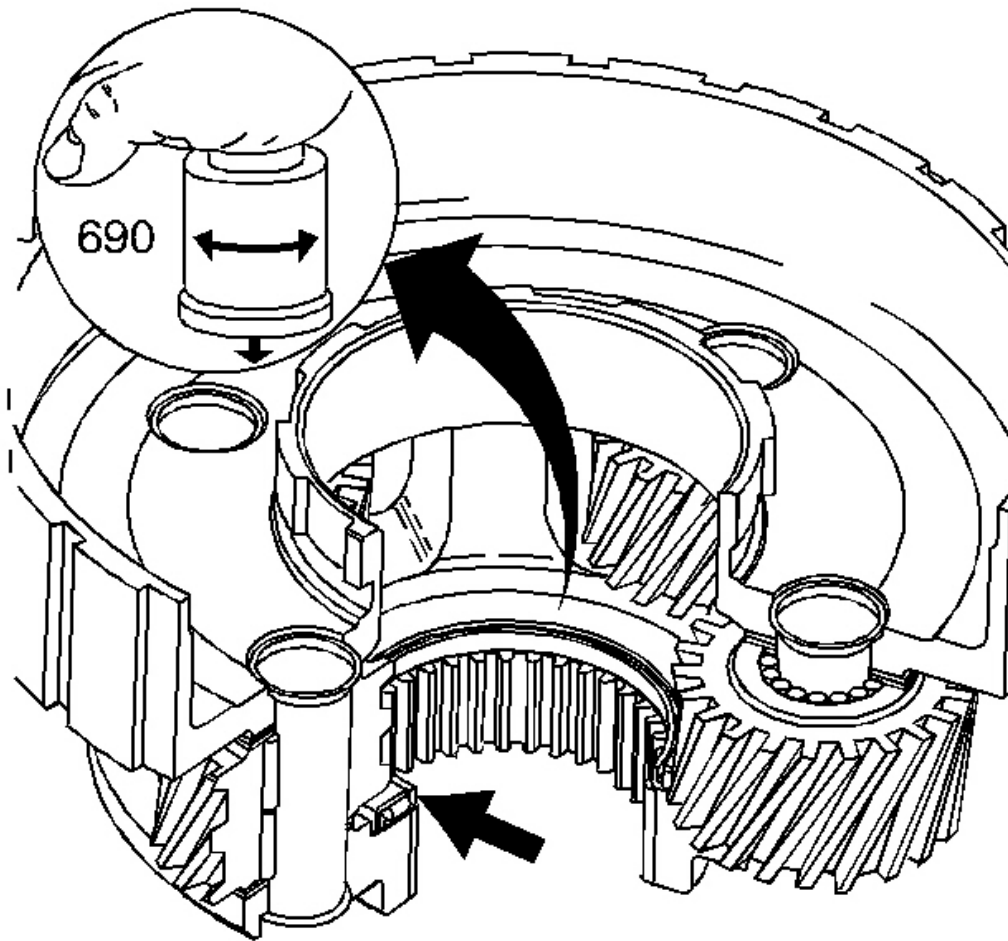

Fig. 271: Illustrating Proper Inspection Of Reaction Carrier Captive Thrust Bearing
Courtesy of GENERAL MOTORS CORP.

6. Inspect the reaction carrier captive thrust bearing for wear or damage.
 1. Without touching the pinion gears, place a bushing or an output shaft sleeve (690) onto the bearing race and turn it with the palm of your hand.
 2. Any imperfections will be felt through the bushing.

REACTION GEAR AND CARRIER INSTALLATION

Tools Required

J 36850 Transjcl Lubricant**Installation Procedure**

Fig. 272: View Of Reaction Carrier/Support Thrust Bearing Assembly
Courtesy of GENERAL MOTORS CORP.

1. Install the reaction gear support to case bearing (692) onto the internal reaction gear support (685). Retain the bearing using **J 36850** or equivalent.
2. Install the internal reaction gear (684) and the internal reaction gear support (685) into the case.

3. Install the reaction carrier/support thrust bearing assembly (683) into the internal reaction gear support (685). Retain bearing with **J 36850** .

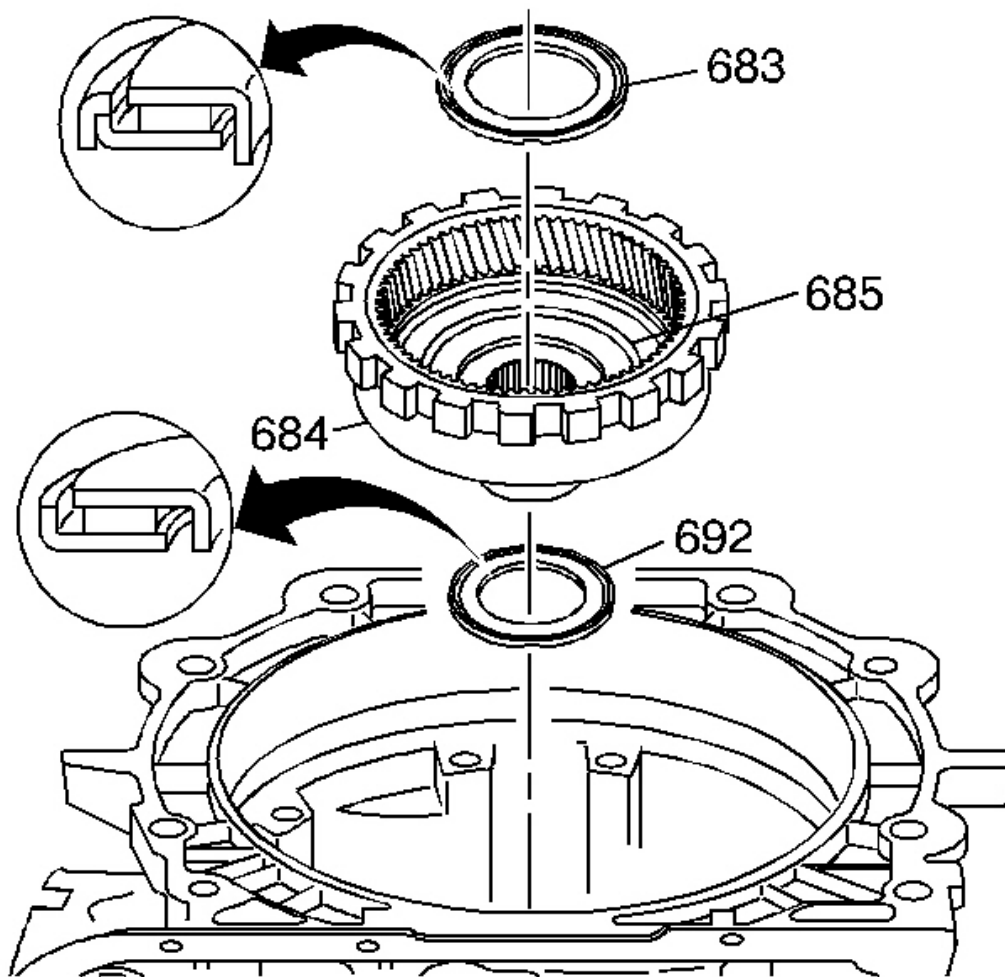
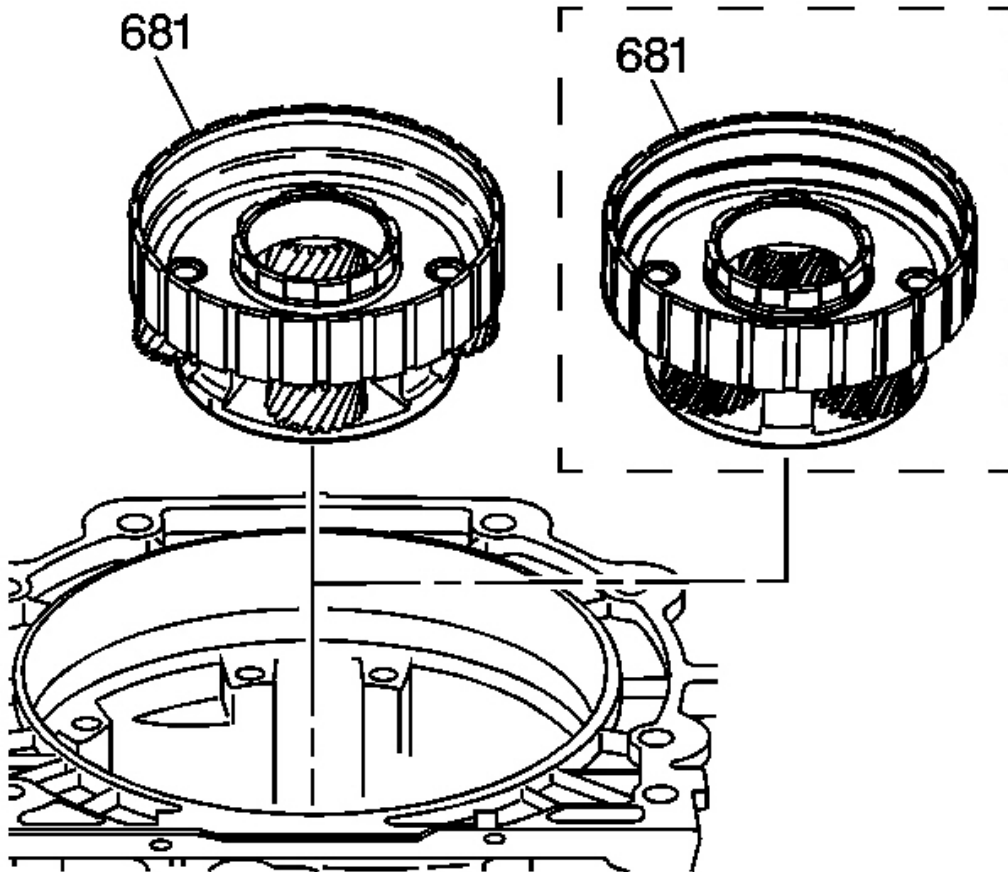

Fig. 273: Identifying Reaction Carrier Assembly
Courtesy of GENERAL MOTORS CORP.

4. Install the reaction carrier assembly (681) into the internal reaction gear.

LOW AND REVERSE CLUTCH SPACER PLATE SELECTION

Tools Required

- **J 8001** Dial Indicator Set
- **J 26900-13** Magnetic Indicator Base

Selection Procedure

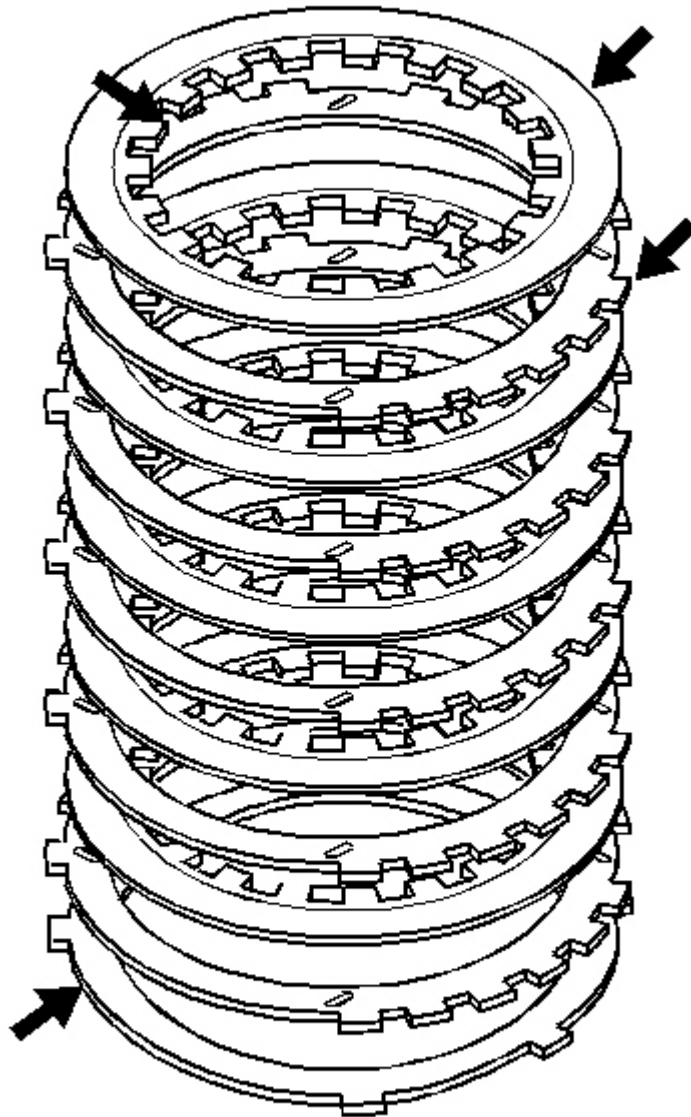

Fig. 274: Locating Inspection Areas On Low And Reverse Clutch Plates
Courtesy of GENERAL MOTORS CORP.

1. Inspect the low and reverse clutch plates for the following conditions:
 - Composition material wear

- Composition material heat damage
- Composition material delamination
- Steel plates heat damage
- Steel plates surface finish damage

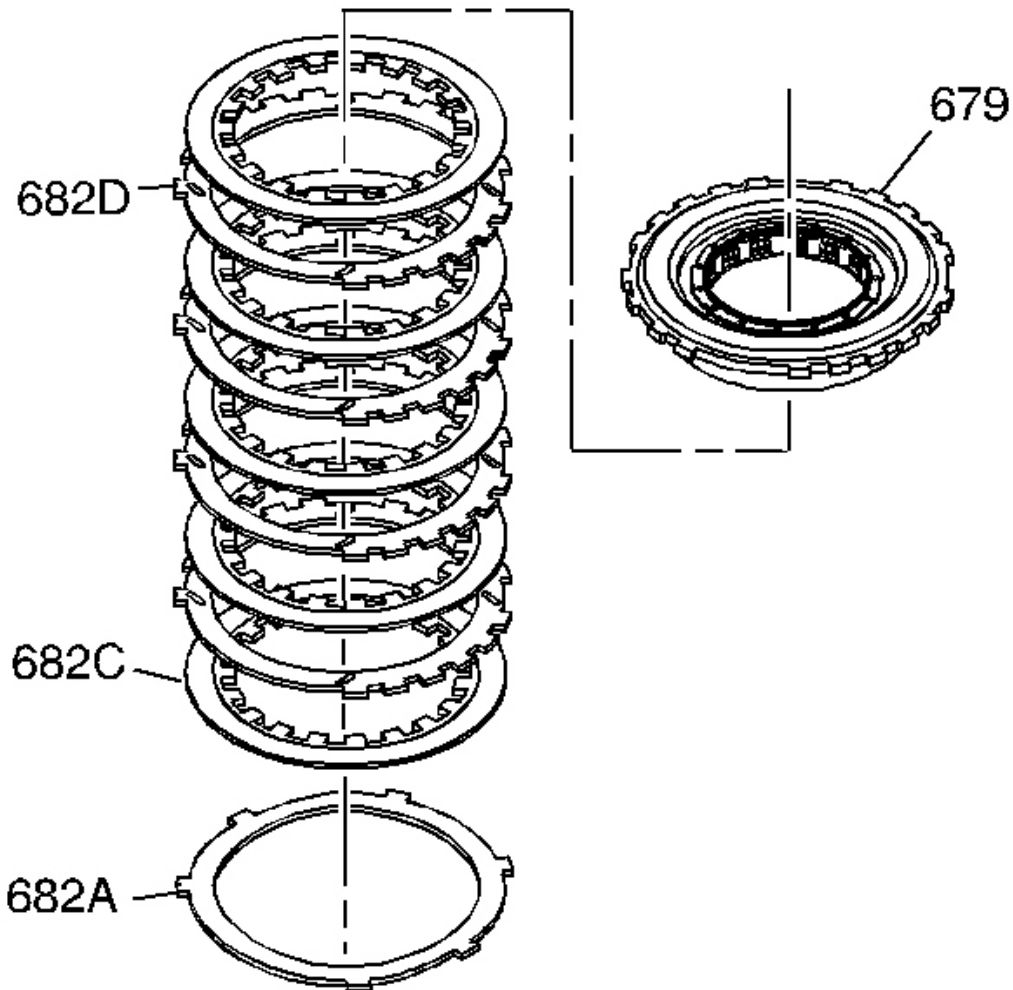

Fig. 275: View Of Low And Reverse Clutch Plate Assembly
Courtesy of GENERAL MOTORS CORP.

2. Stack the low and reverse clutch plate assembly on a flat surface in the following order:

1. One waved plate (682A)
2. Five fiber plate assemblies (682C) and four steel plates (682D), starting with one fiber plate assembly and alternating with steel
3. Low and reverse clutch support (679)

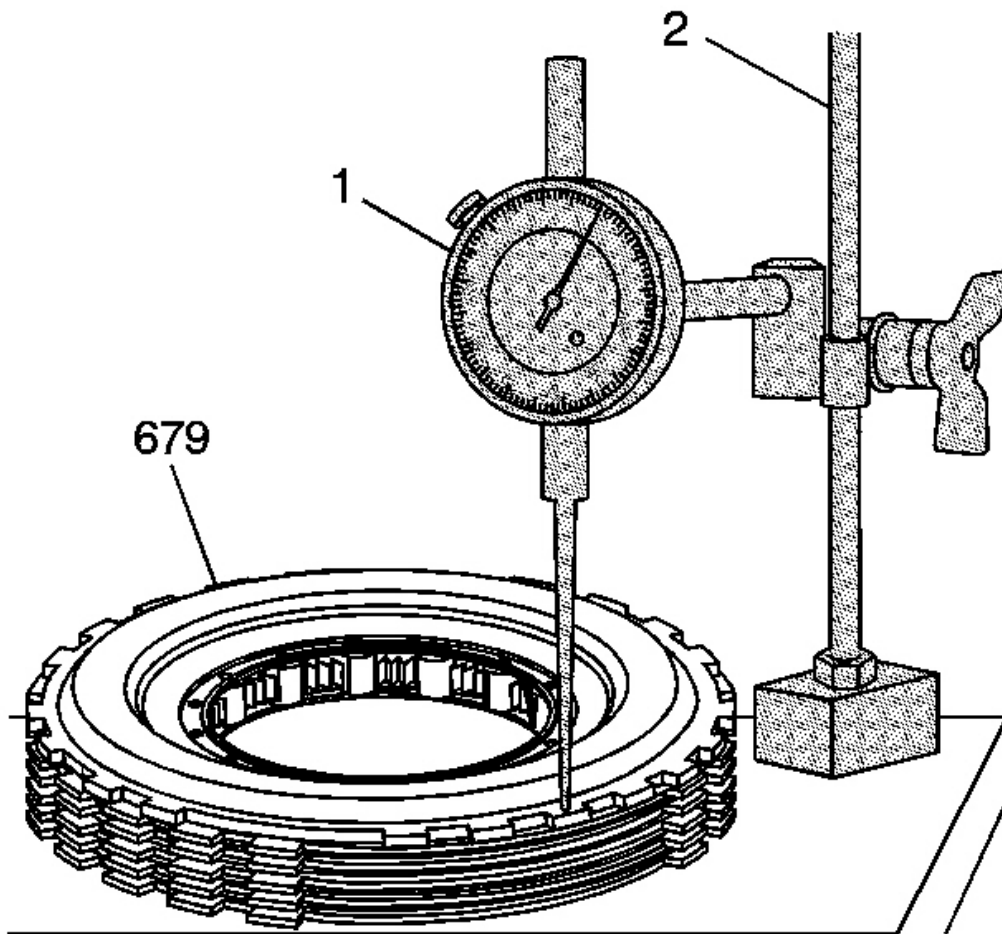

Fig. 276: Measuring Clutch Pack Height With J 8001
Courtesy of GENERAL MOTORS CORP.

3. Using the **J 8001** (1) and the **J 26900-13** (2), measure the height of the clutch pack from the work surface to the top of the low and reverse clutch support (679).
4. Refer to **Low and Reverse Clutch Spacer Plate Selection** in order to select the proper

thickness of the low and reverse clutch selective spacer plate (682B).

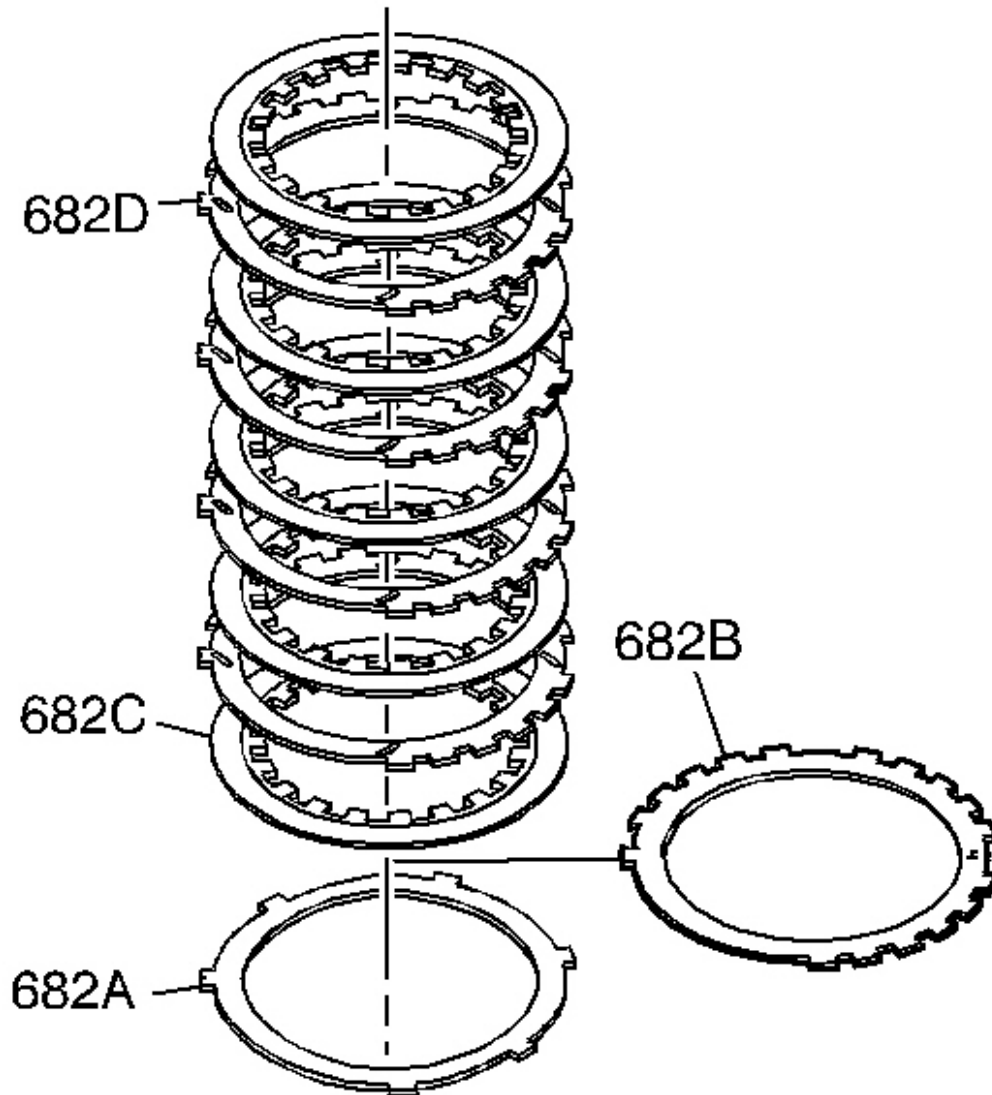

Fig. 277: View Of Clutch Pack
Courtesy of GENERAL MOTORS CORP.

5. Install the proper selective spacer plate (682B) between the wave plate (682A) and the first fiber plate assembly (682C), with the identification side up.

The overall height for the clutch pack including the selective spacer plate should be 29.23-29.90 mm (1.15-1.18 in).

LOW AND REVERSE CLUTCH PLATE INSTALLATION

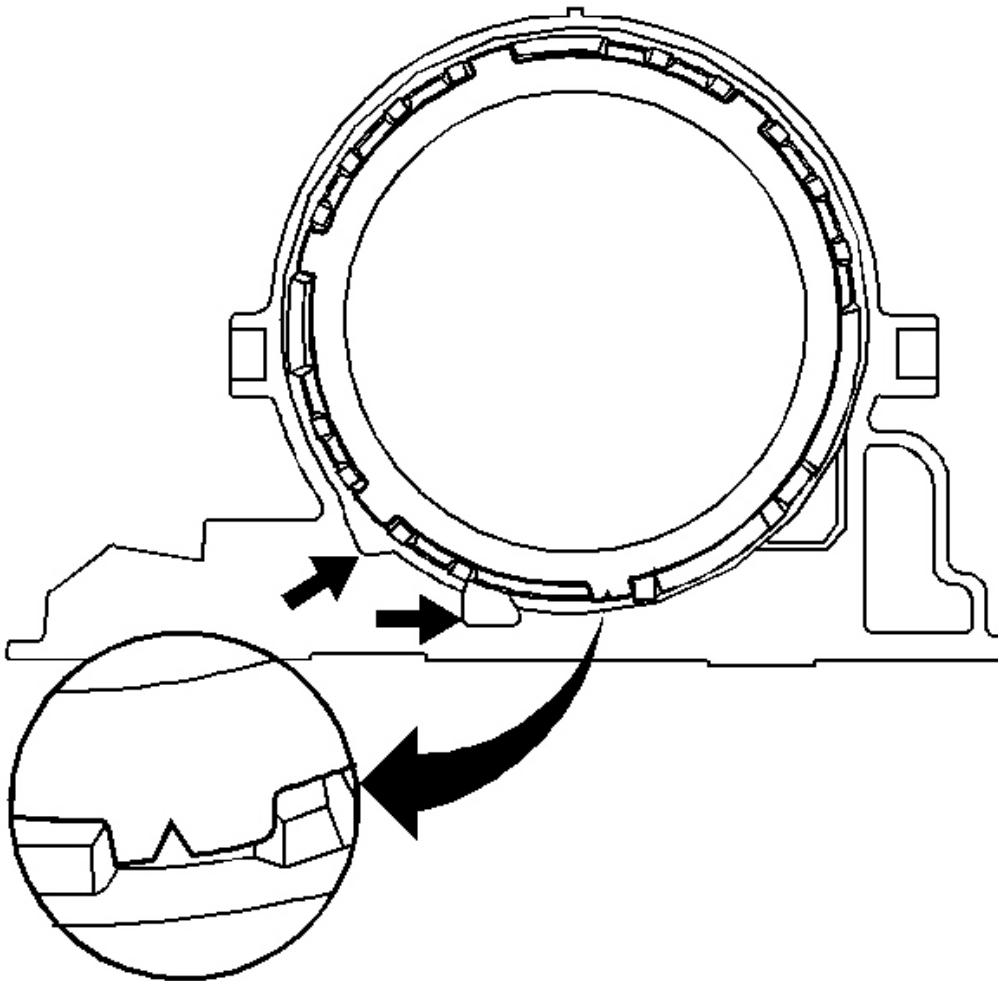

Fig. 278: Illustrating Steel Plate Spline Alignment
Courtesy of GENERAL MOTORS CORP.

1. Install the waved plate.
2. Install the correct selective spacer plate (from the selection procedure).
3. Install the five fiber plate assemblies and four steel plates, starting with one fiber plate

assembly and alternating with steel.

4. Index the steel plate splines in the case as shown.

LOW AND REVERSE CLUTCH SUPPORT DISASSEMBLE

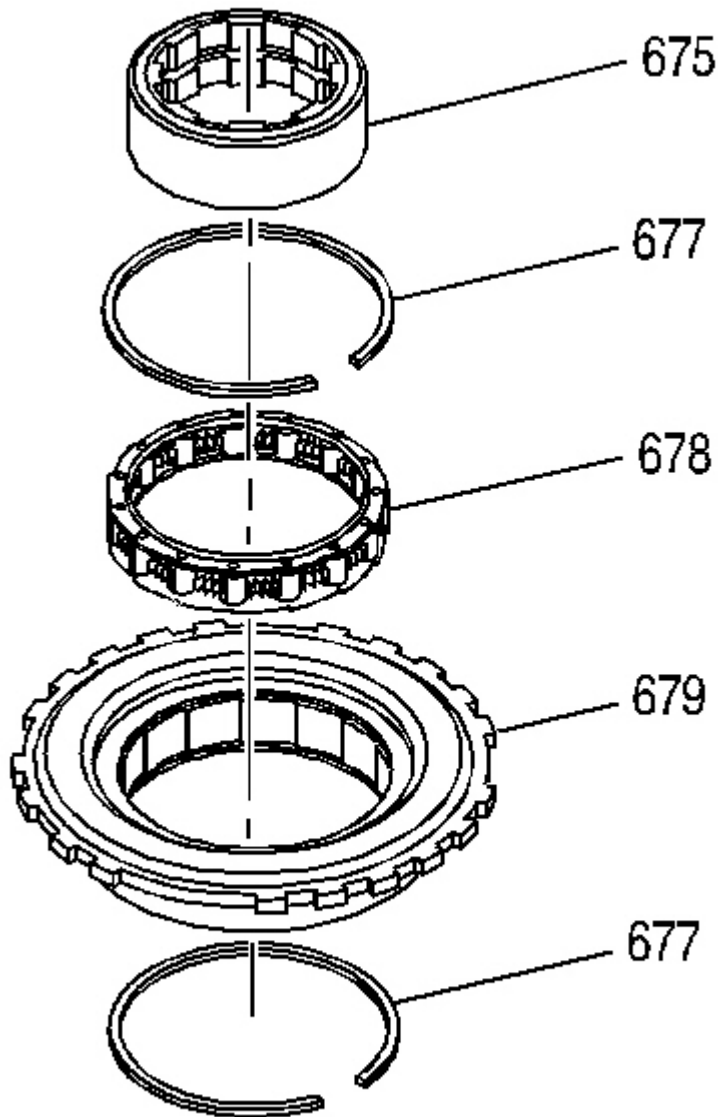

Fig. 279: Low and Reverse Clutch Support Components

2007 Hummer H3

2007 TRANSMISSION Automatic Transmission - 4L60-E/4L65-E/4L70-E - H3

Courtesy of GENERAL MOTORS CORP.

1. Remove the low and reverse roller clutch race (675) from the low and reverse clutch support (679). Inspect the race for damage and surface finish.
2. Remove the two low and reverse roller retainer rings (677) and the low and reverse roller clutch assembly (678). Inspect the roller clutch assembly for damaged rollers and broken springs.
3. Inspect the low and reverse clutch support (679) for loose cam and cam surface finish. Check the support for cracks and damaged lugs.

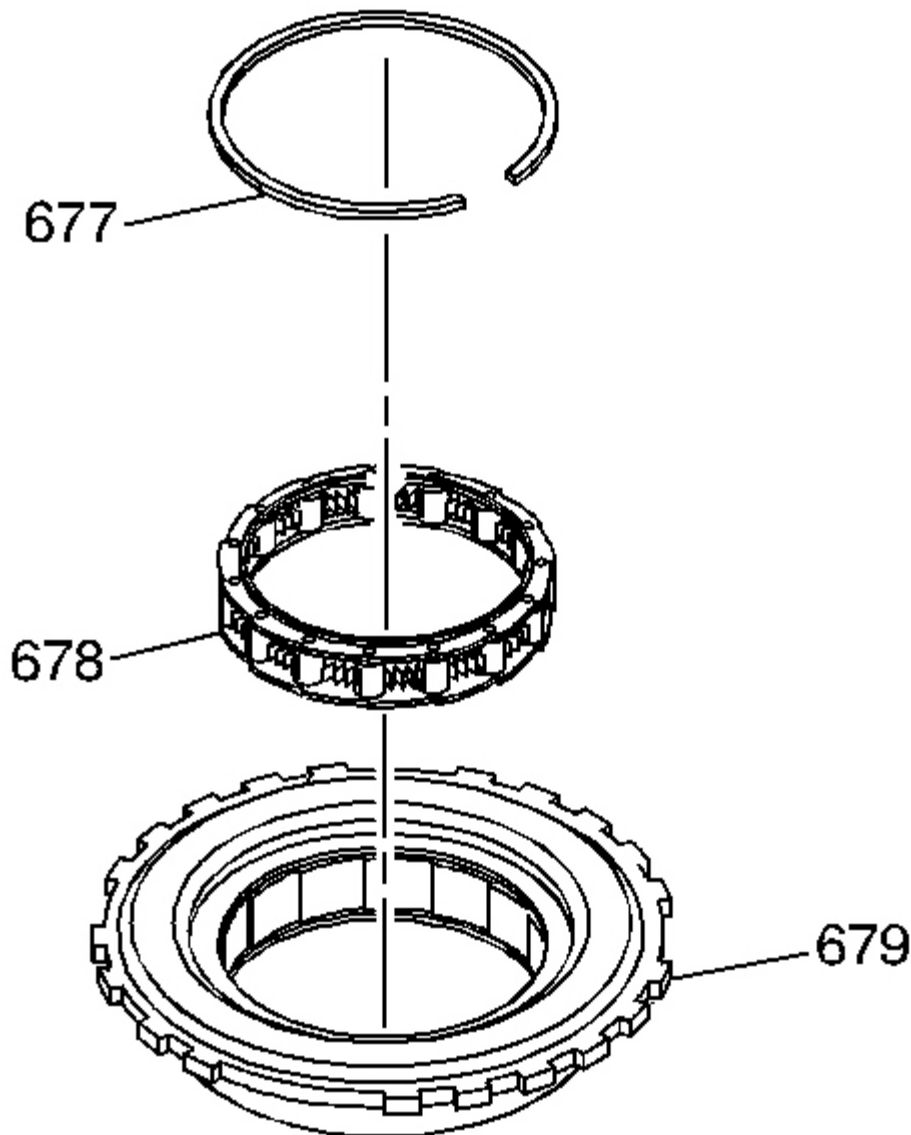

Fig. 280: Identifying Low And Reverse Roller Clutch Assembly
Courtesy of GENERAL MOTORS CORP.

4. Clean and install the low and reverse roller clutch assembly (678) into the low and reverse clutch support (679). Install the low and reverse retainer ring (677).

LOW AND REVERSE CLUTCH SUPPORT INSTALLATION

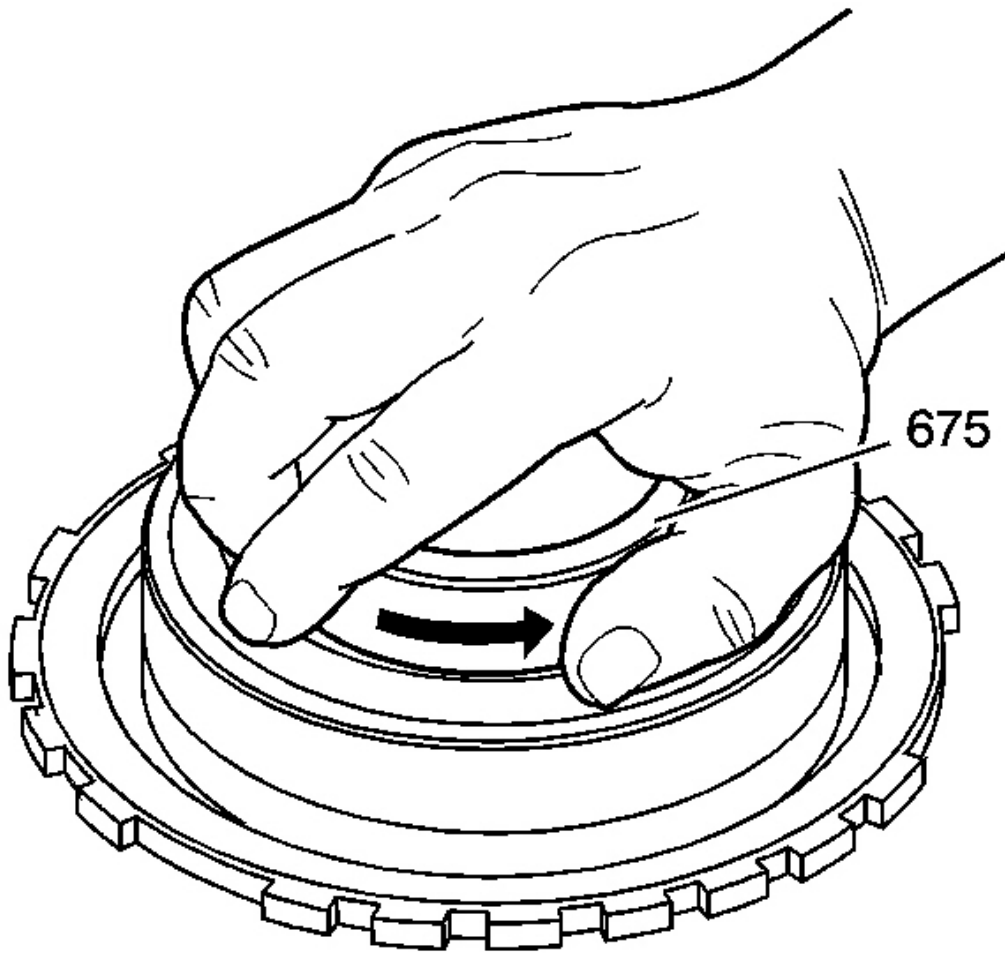

Fig. 281: Checking Low And Reverse Roller Clutch Race Rotation
Courtesy of GENERAL MOTORS CORP.

1. Install the low and reverse roller clutch race (675). Simultaneously, turn and insert the race.
2. Rotate the race in order to verify proper operation. The race should only rotate in one direction.

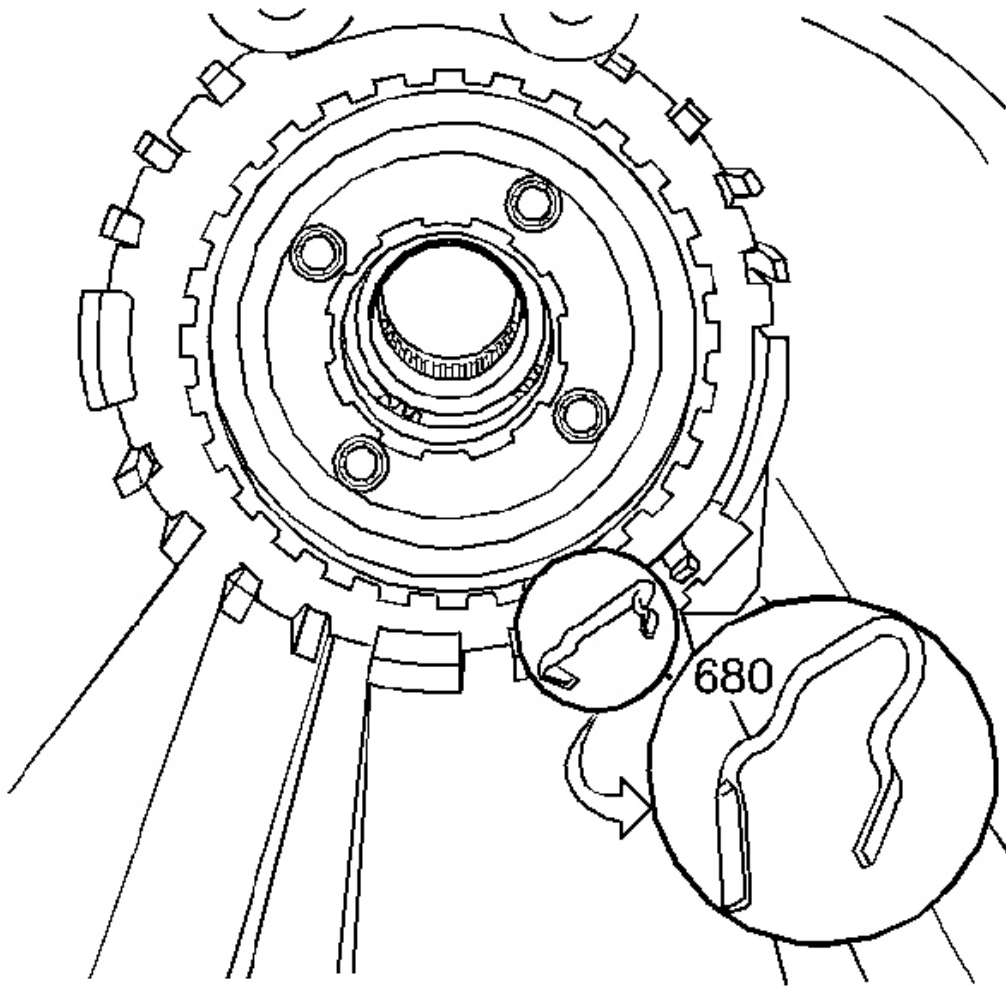

Fig. 282: View Of Low And Reverse Clutch Support Retainer Spring
Courtesy of GENERAL MOTORS CORP.

3. Install the low and reverse clutch support retainer spring (680) into the case.

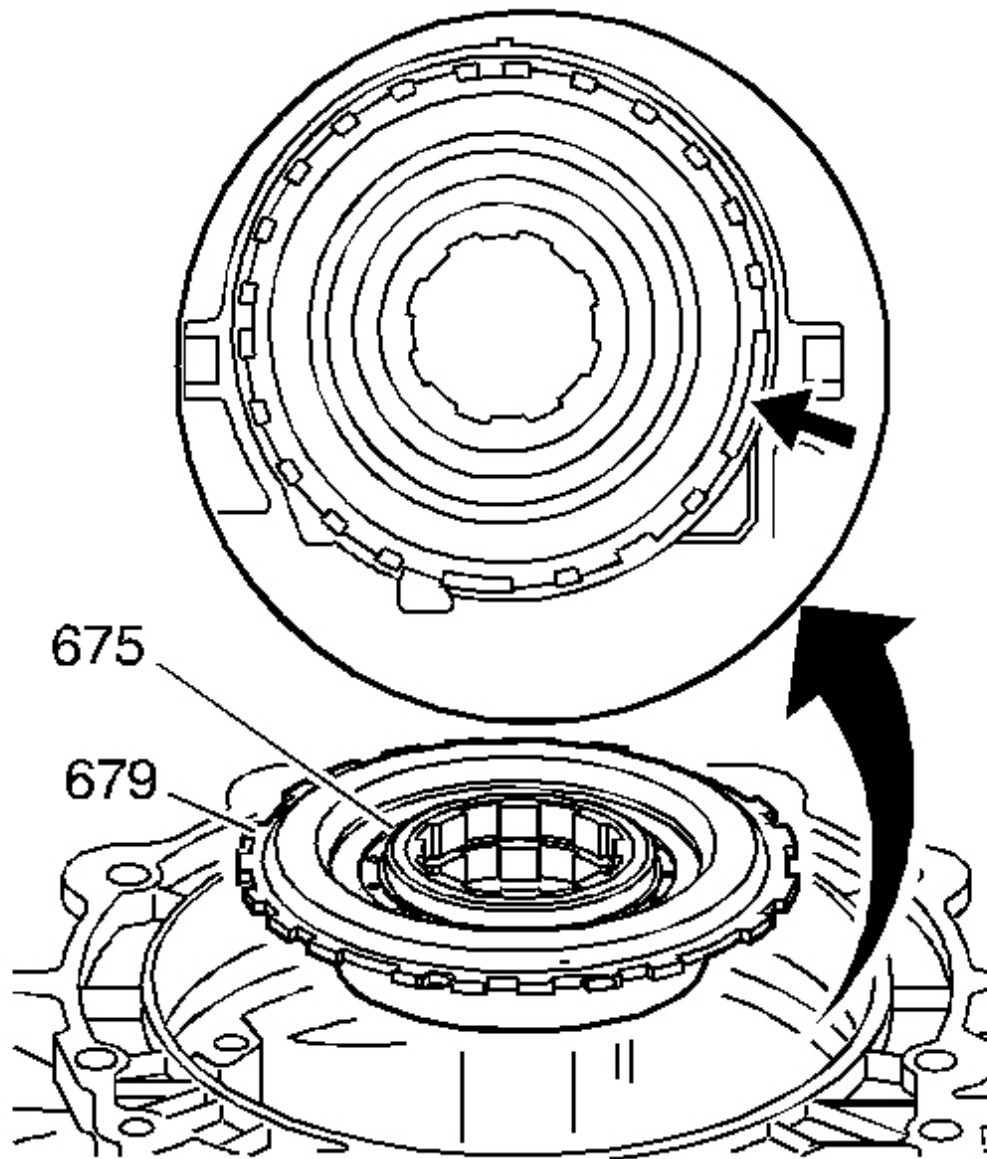

Fig. 283: Aligning Wide Case Lug With Wide Low And Reverse Clutch Support Notch

Courtesy of GENERAL MOTORS CORP.

IMPORTANT: Align the wide low and reverse clutch support notch with the

wide case lug.

4. Install the low and reverse clutch support (679), roller clutch and roller clutch race (675) assembly into the case. Position the hub side down during the installation.

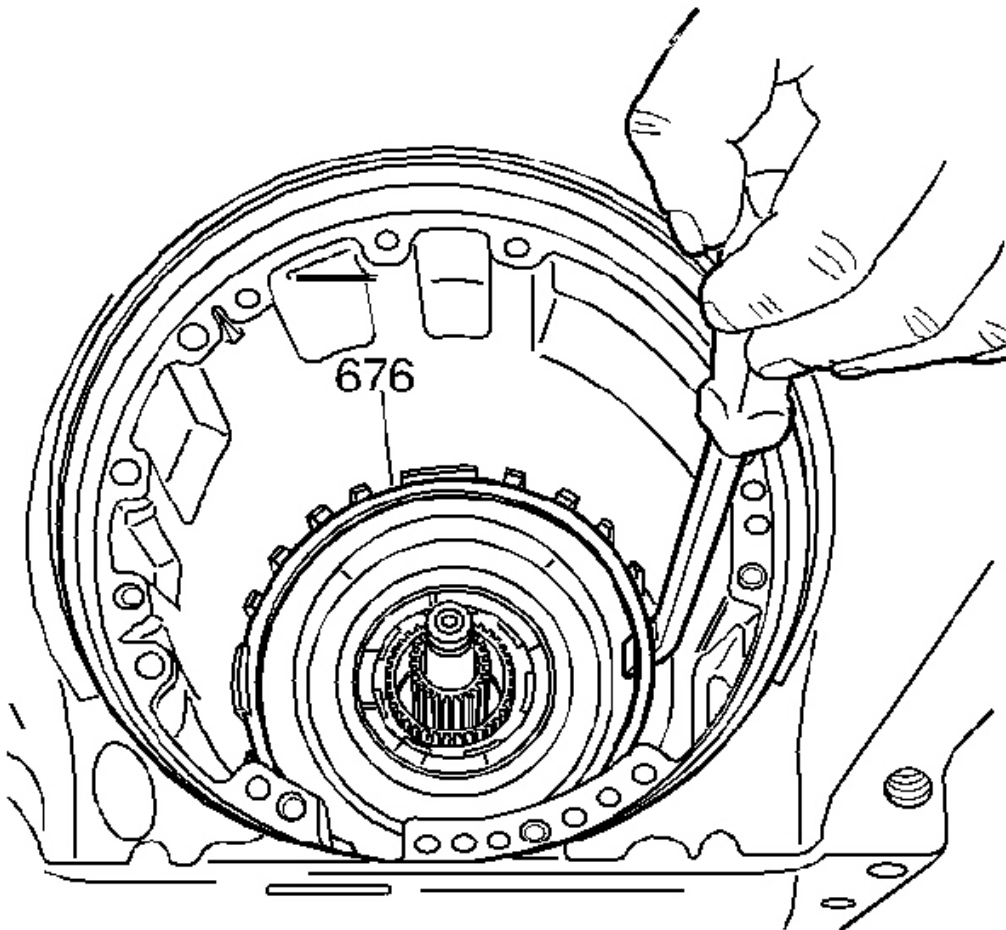

Fig. 284: Removing Low And Reverse Support Retainer Ring
Courtesy of GENERAL MOTORS CORP.

IMPORTANT: Align the opening of the low and reverse clutch support retainer ring (676) with the low and reverse clutch support retainer spring (680). It is important that the low and reverse clutch support retainer ring opening is centered around the

retainer spring. This will allow the retainer ring to fully seat in all of the transmission case lugs. If the retainer ring lays up against the retainer spring, the retainer ring will not fully seat. Possible damage to the transmission case lugs can occur if the low and reverse clutch support retainer ring is not fully seated in the transmission case lug.

5. Install the low and reverse support retainer ring (676) into the case.

REACTION SUN GEAR INSTALLATION

Tools Required

- **J 34196-B** Transmission Bushing Service Set. See **Special Tools**.
- **J 8092** Driver Handle

Installation Procedure

IMPORTANT: Do not remove the retaining ring (671), except to replace it.

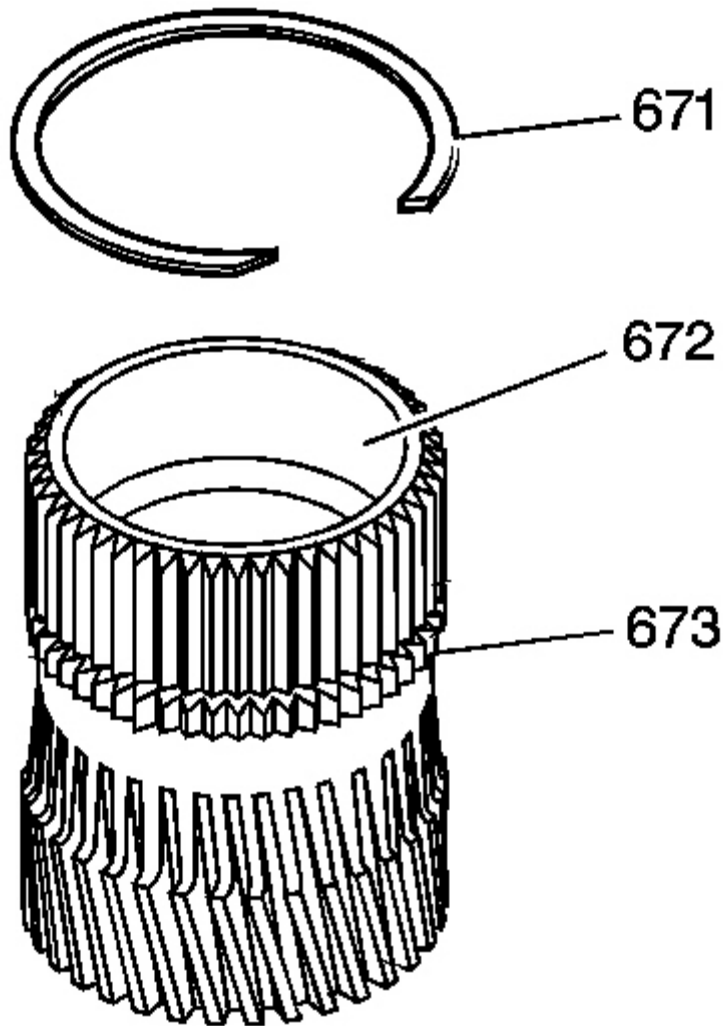

Fig. 285: Inspection Areas On Reaction Sun Gear
Courtesy of GENERAL MOTORS CORP.

1. Inspect the reaction sun gear (673) for the following defects:
 - Nicks
 - Scores
 - Damaged spline or teeth
 - A worn bushing (672)

- A loose or weak retaining ring (671)

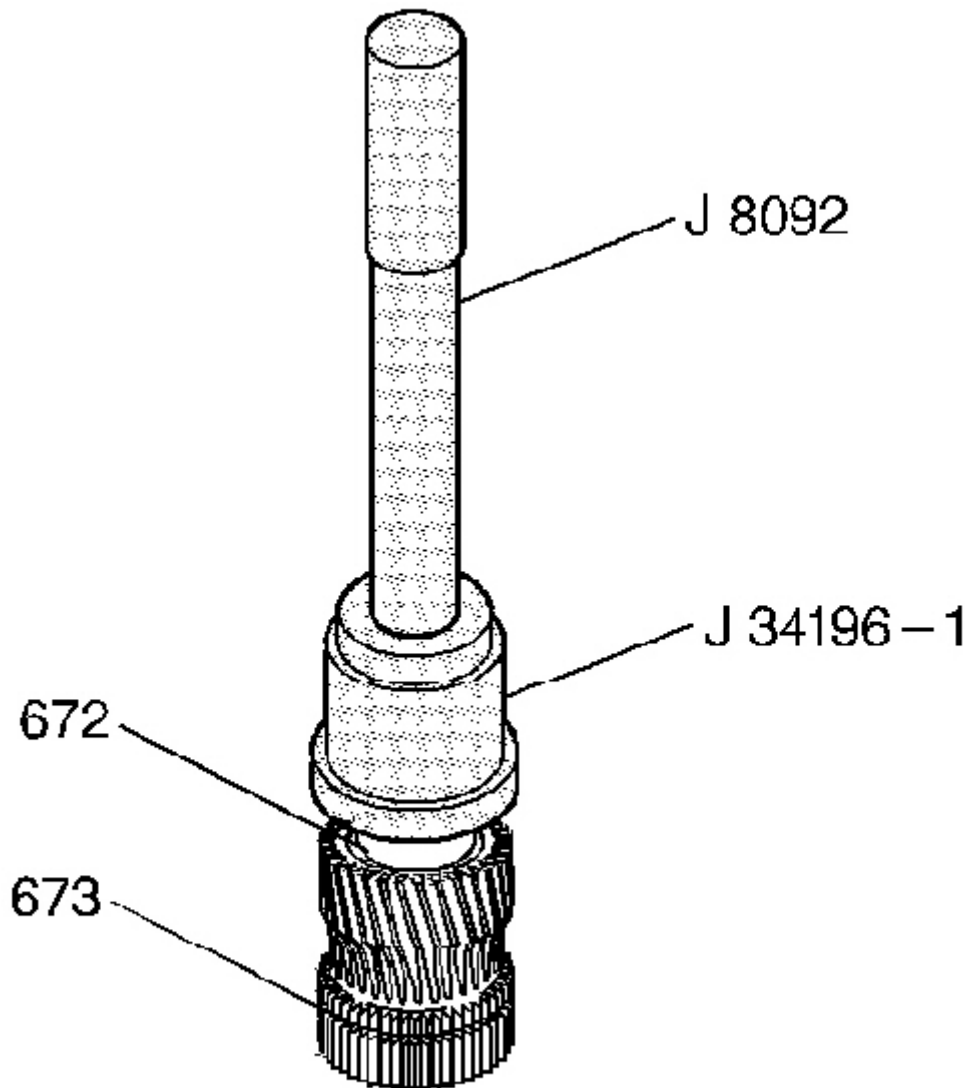

Fig. 286: Removing Reaction Sun Bushing From Reaction Sun Gear
Courtesy of GENERAL MOTORS CORP.

2. If the reaction sun gear bushing (672) needs replacement, use J 34196-1 which is part of kit **J 34196-B** with **J 8092** to remove the reaction sun bushing (672) from the reaction sun gear

(673). See **Special Tools**.

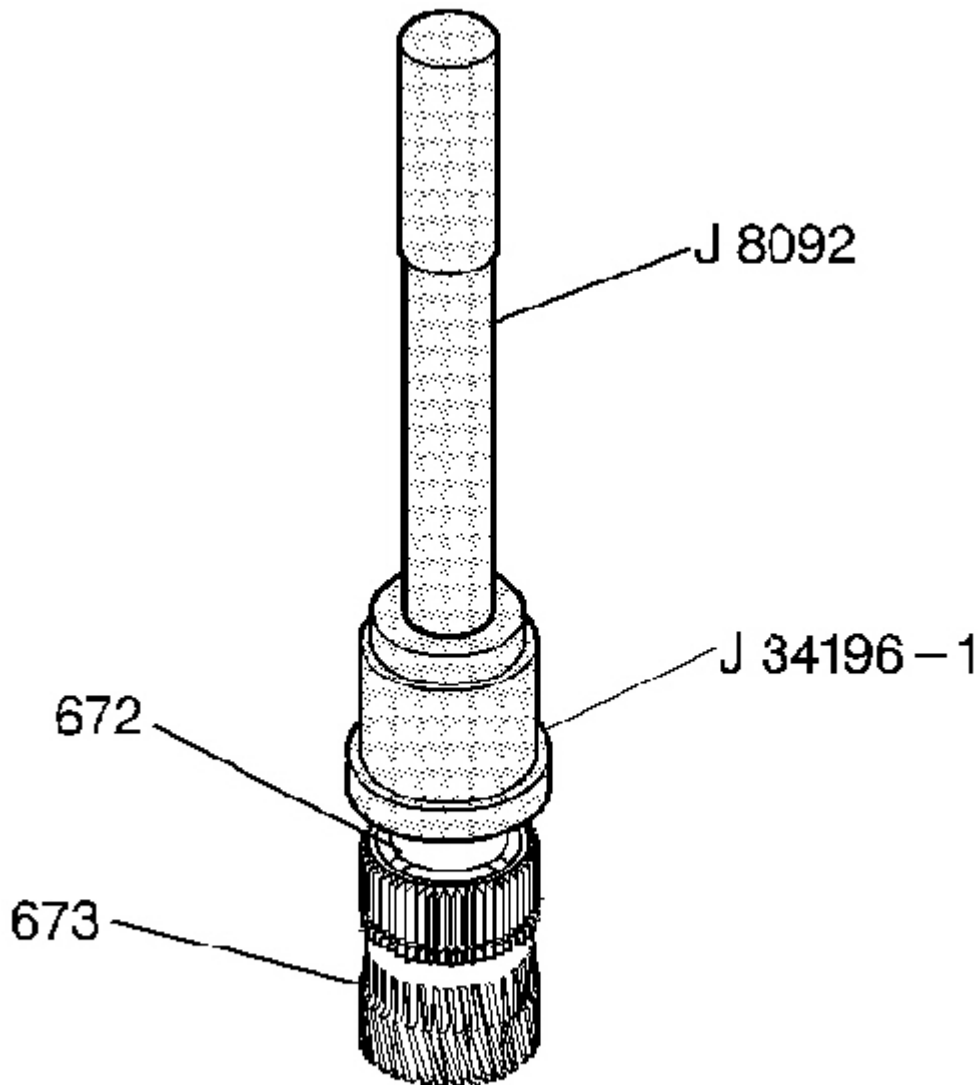

Fig. 287: Installing Reaction Sun Bushing
Courtesy of GENERAL MOTORS CORP.

- Using J 34196-1 which is part of kit J 34196-B with J 8092 , install a new reaction sun bushing (672) into the reaction sun gear (673). See **Special Tools**.

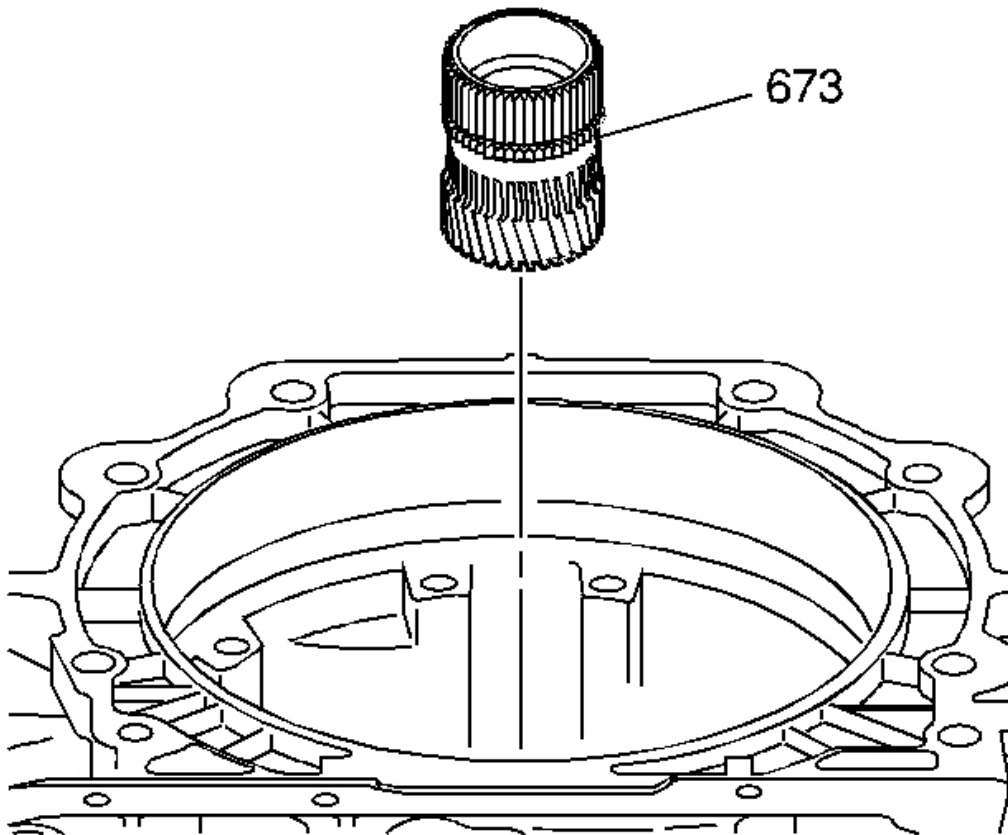

Fig. 288: Identifying Reaction Sun Gear
Courtesy of GENERAL MOTORS CORP.

4. Install the reaction sun gear (673) into the reaction carrier.

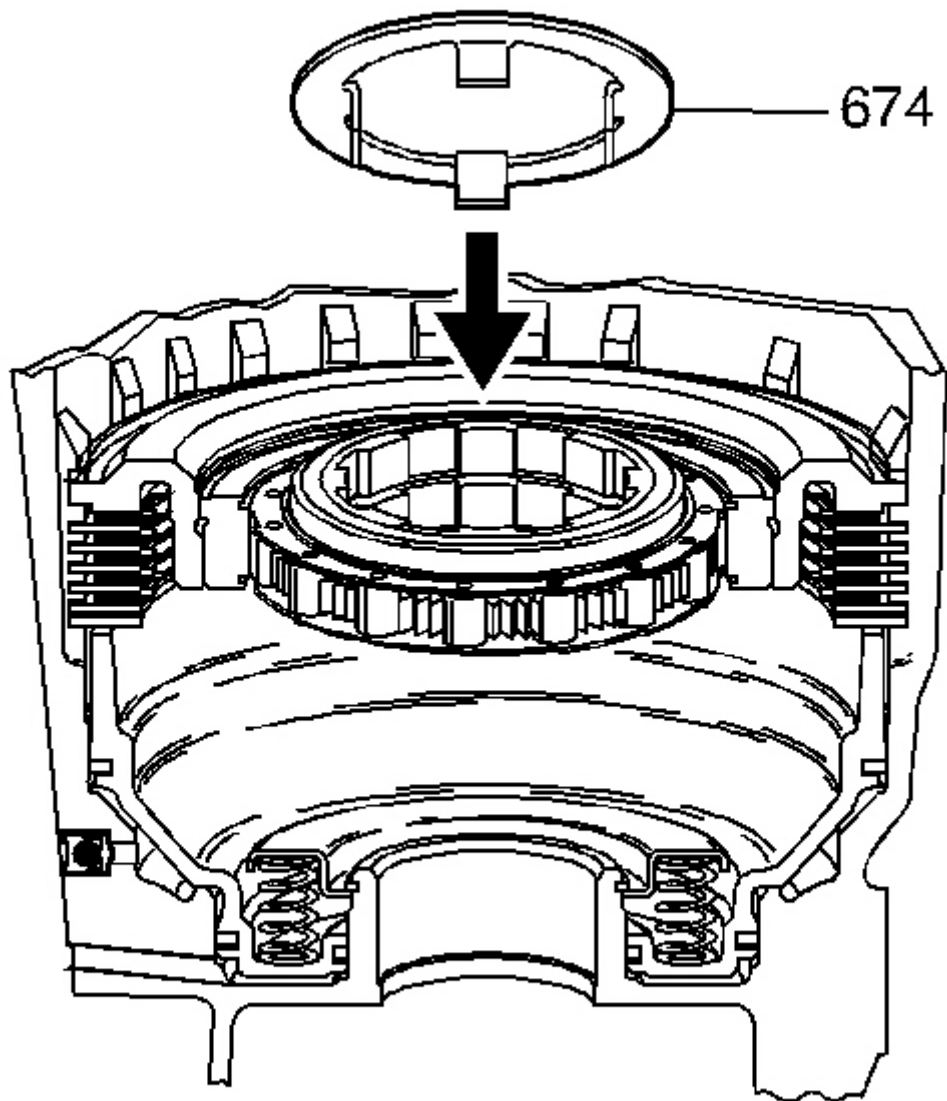

Fig. 289: Aligning Thrust Washer Tangs With Low And Reverse Roller Clutch Race Splines

Courtesy of GENERAL MOTORS CORP.

5. Install the thrust washer (674) with the tangs pointing down. Index the tangs of the thrust washer with the splines of the low and reverse roller clutch race.

REACTION CARRIER SHAFT REPLACEMENT

Tools Required

- **J 8092** Universal Driver Handle - 3/4 in - 10
- **J 7004-A** Universal Remover. See **Special Tools**.
- **J 23907** Slide Hammer with Bearing Adapter
- **J 25019-14** Stator Pump Bushing Remover
- **J 29369-2** Bushing and Bearing Remover 2-3 in
- **J 34196-B** Transmission Bushing Service Set. See **Special Tools**.

Removal Procedure

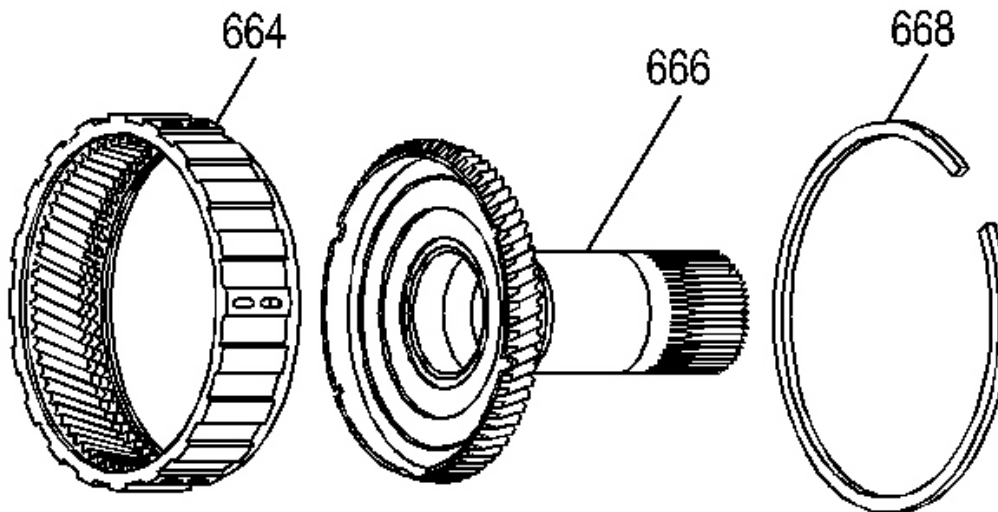

Fig. 290: Identifying Reaction Carrier Components
Courtesy of GENERAL MOTORS CORP.

1. Remove the reaction carrier shaft/internal gear retainer (668) and the reaction carrier shaft (666) from the input internal gear (664).
2. Inspect the reaction carrier shaft (666) and the input internal gear (664) for the following defects:
 - Scoring

2007 Hummer H3

2007 TRANSMISSION Automatic Transmission - 4L60-E/4L65-E/4L70-E - H3

- Cracking
- Damaged or worn bushings
- A cracked shaft
- A damaged spline
- Damaged gear teeth

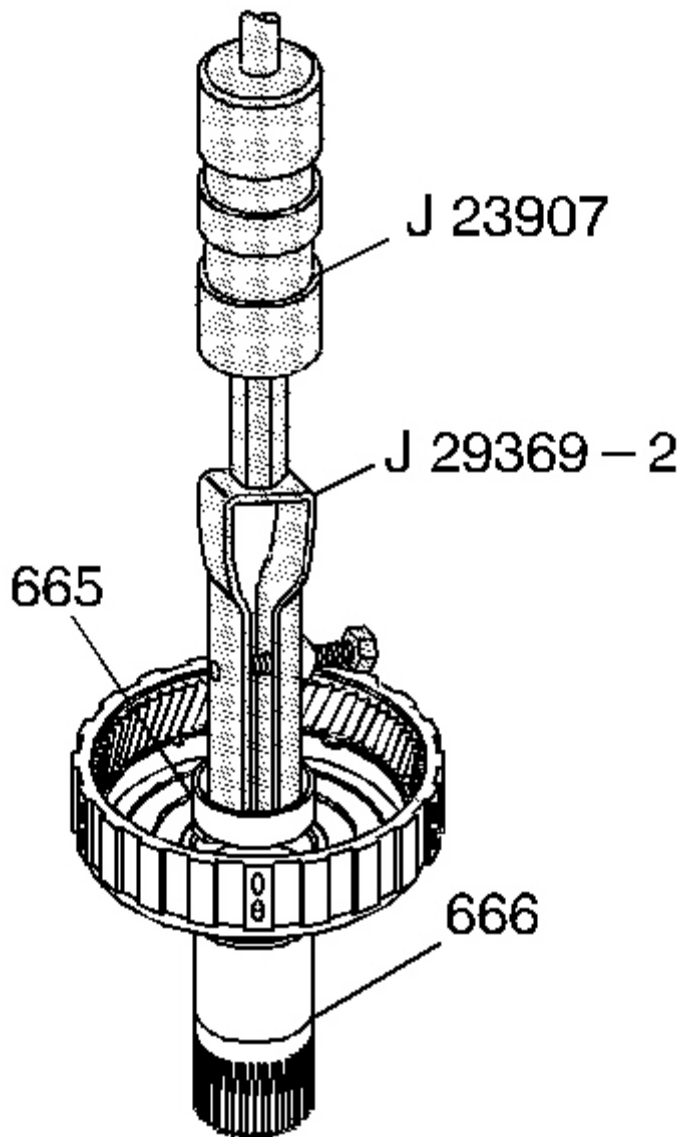

Fig. 291: Removing Reaction Carrier Shaft Front Bushing
Courtesy of GENERAL MOTORS CORP.

3. Using J 29369-2 with J 23907 , remove the reaction carrier shaft front bushing (665).

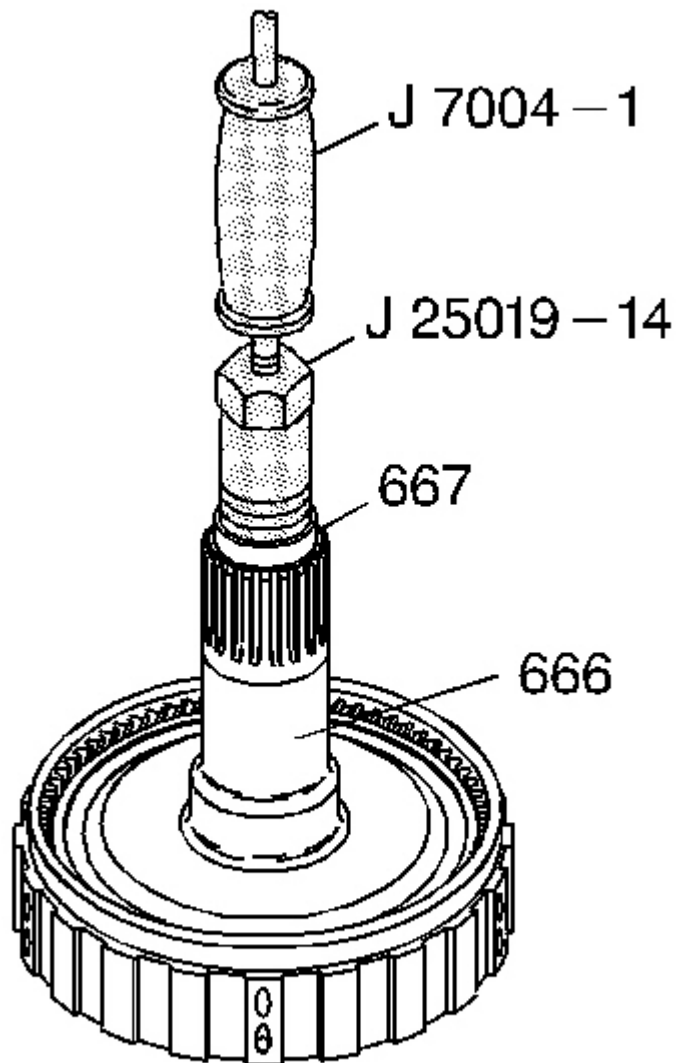

Fig. 292: Using J 25019-14 & J 25019-14 To Remove Reaction Carrier Shaft Rear Bushing

Courtesy of GENERAL MOTORS CORP.

4. Using J 25019-14 with J 7004-A , remove the reaction carrier shaft rear bushing (667). See **Special Tools**.

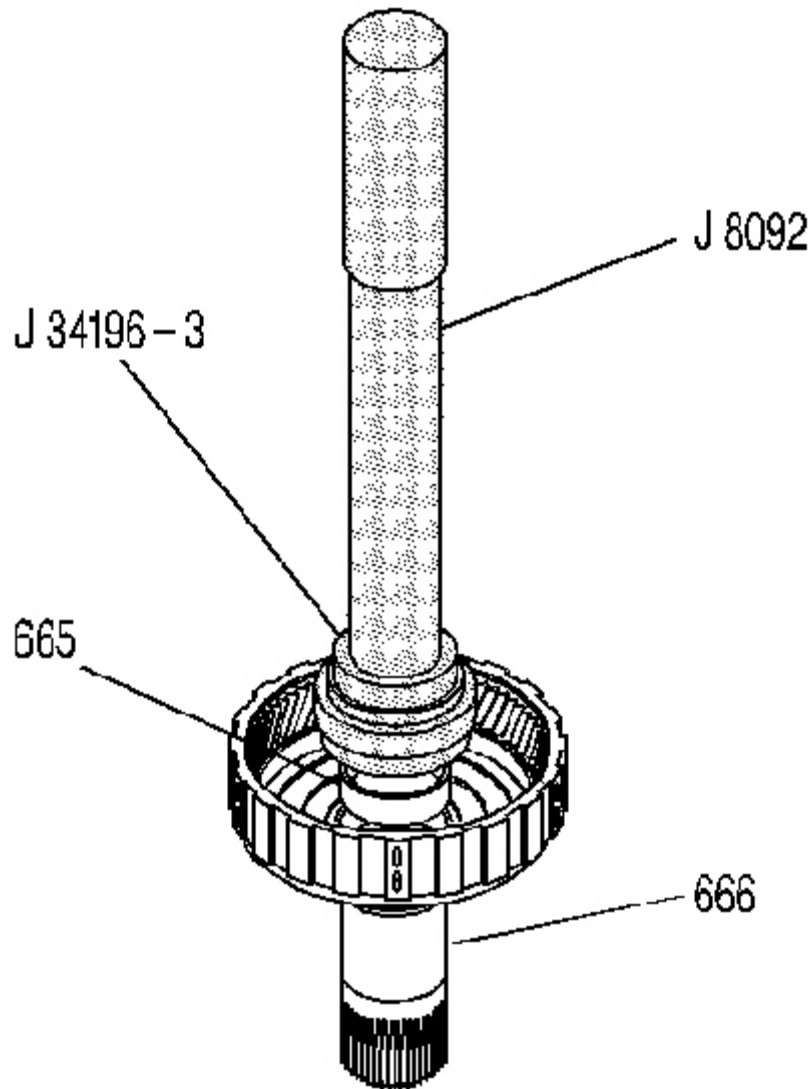

Fig. 293: Installing Reaction Carrier Shaft Front Bushing
Courtesy of GENERAL MOTORS CORP.

1. Using J 34196-3 which is part of kit J 34196-B with J 8092 , install a new reaction carrier shaft front bushing (665). See **Special Tools**.

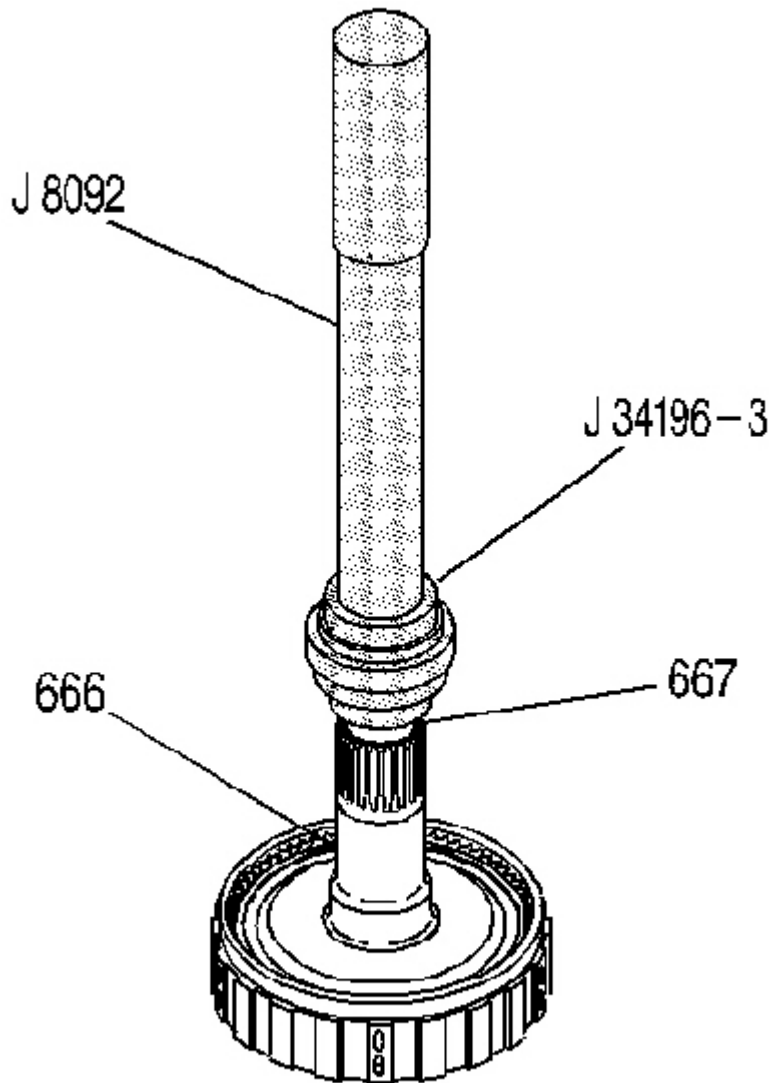

Fig. 294: View Of Reaction Carrier Shaft Rear Bushing
Courtesy of GENERAL MOTORS CORP.

2. Using J 34196-3 which is part of kit J 34196-B with J 8092 , install a reaction carrier shaft rear bushing (667). See **Special Tools**.

Tools Required**J 36850** Transjel Lubricant**Installation Procedure**

Fig. 295: View Of Input Internal Gear, Reaction Shaft & Sun Shell
Courtesy of GENERAL MOTORS CORP.

1. Install the reaction sun shell (670) into the reaction sun gear.
2. Install the thrust bearing (669) using **J 36850** onto the reaction carrier shaft, tangs up,

toward the shaft.

3. Install the input internal gear (664) and reaction carrier shaft (666) assembly into the sun gear shell. Index the reaction carrier shaft spline into the reaction carrier.

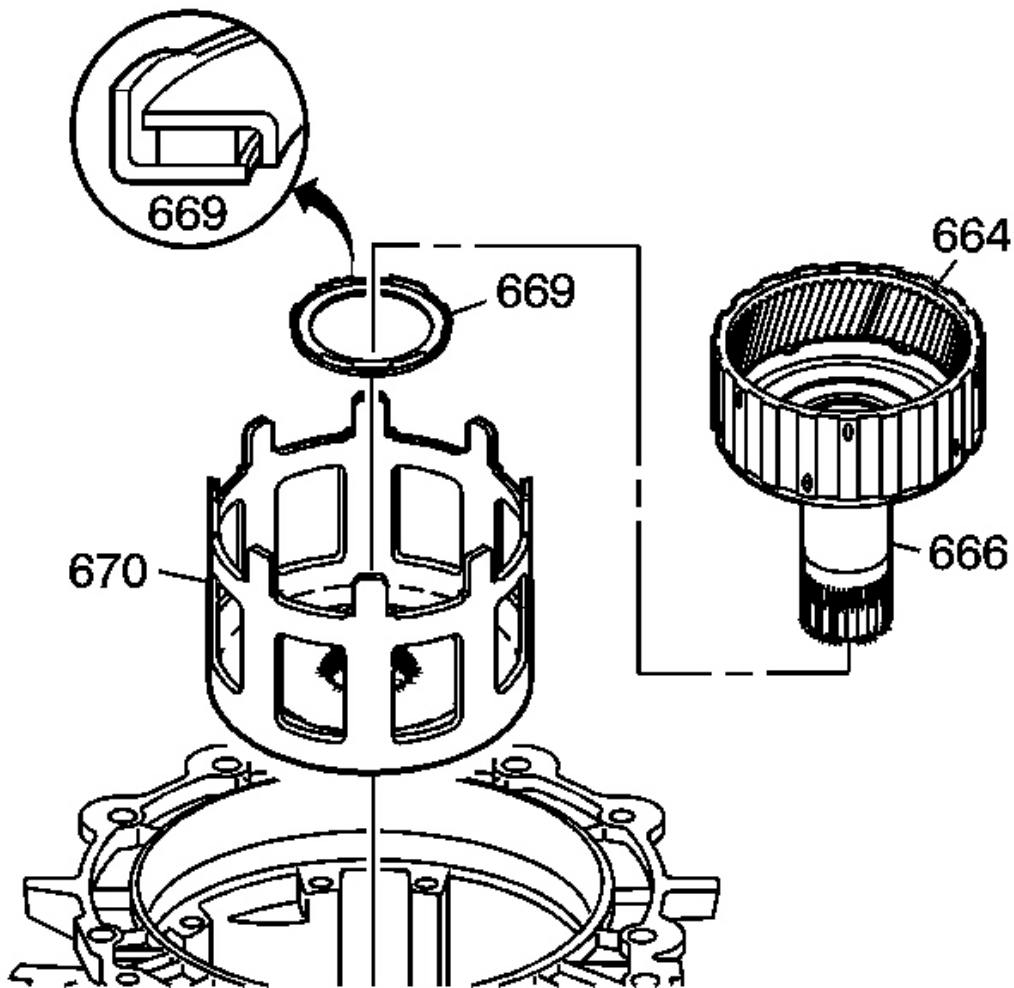
INTERNAL TRANSMISSION SPEED SENSOR ROTOR REPLACEMENT

Tools Required

- **J 8433** Two Jaw Puller
- **J 21427-A** Speedometer Gear Puller Adapter. See **Special Tools**.
- **J 36352** Speed Sensor Rotor Installer Kit. See **Special Tools**.

Removal Procedure

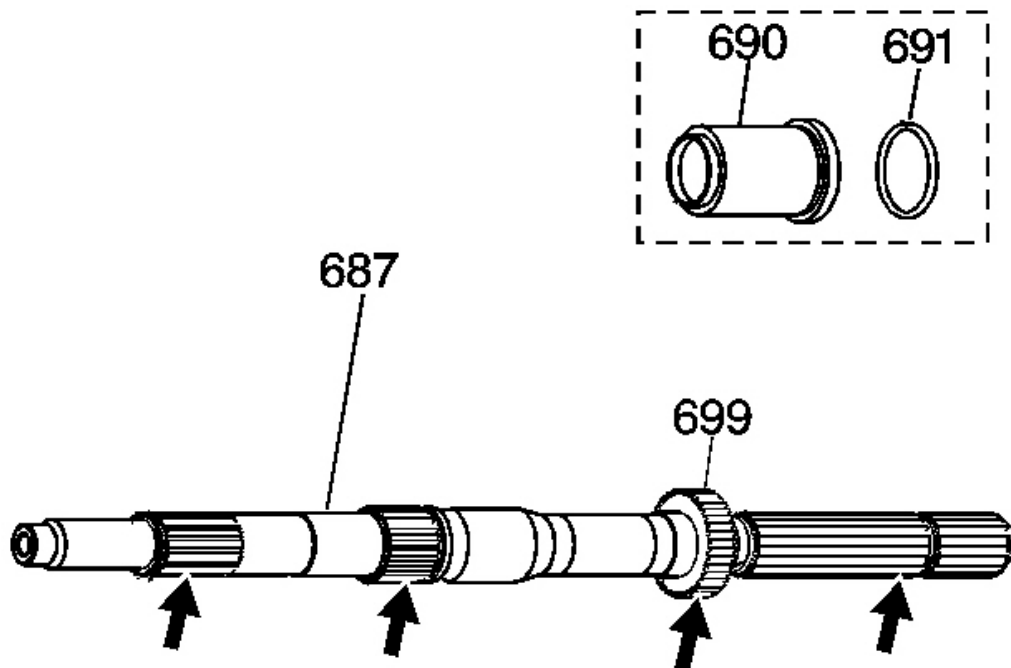

Fig. 296: Identifying Output Shaft Seal & Output Shaft Sleeve
 Courtesy of GENERAL MOTORS CORP.

1. Inspect the internal transmission speed sensor rotor (699) for cracks or damaged teeth.
2. Inspect all splines on the output shaft (687) for cracks or damaged splines.

3. Remove the output shaft seal (691) and the output shaft sleeve (690) (model dependent) 2WD units only.

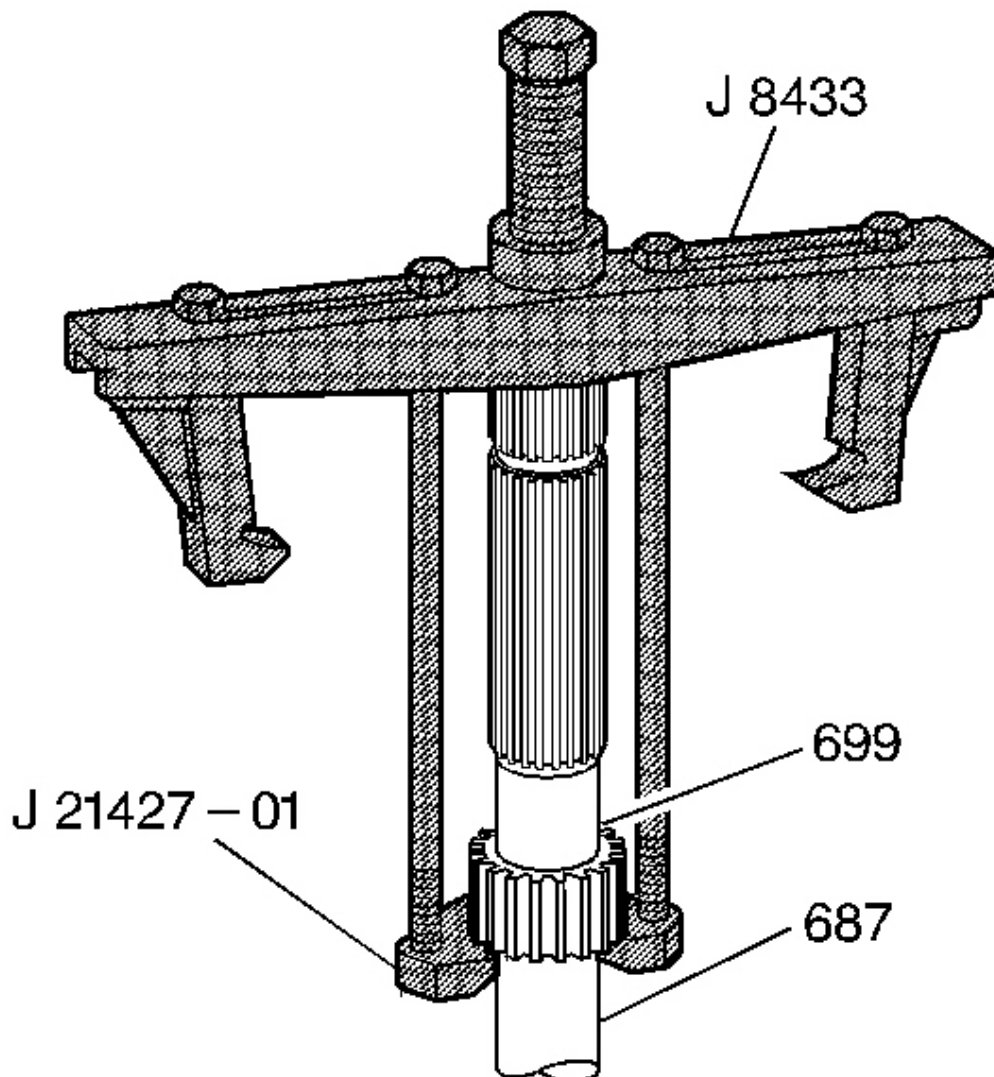

Fig. 297: Using J 8433 & J 21427-01 To Remove Internal Speed Sensor Rotor
Courtesy of GENERAL MOTORS CORP.

4. If the internal speed sensor rotor (699) is damaged, replace it.

5. Using **J 8433** with **J 21427-01** , remove the internal speed sensor rotor (699) from the output shaft (687). See **Special Tools**.

Installation Procedure

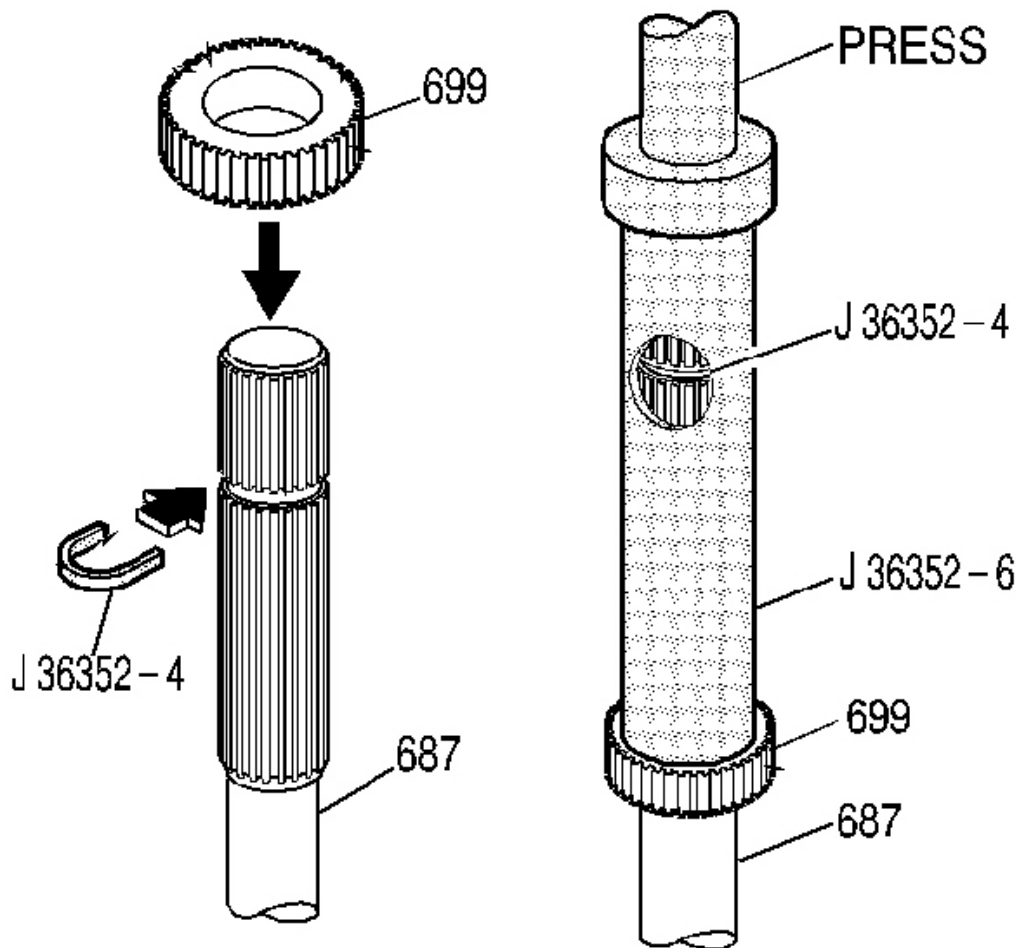

Fig. 298: Pressing Internal Speed Sensor Rotor Onto Output Shaft
Courtesy of GENERAL MOTORS CORP.

IMPORTANT: Do not re-use an internal speed sensor rotor that has been removed.

1. Slip a new internal speed sensor rotor (699) over the output shaft splines.
2. Install the **J 36352-4** in the groove on the output shaft (687). See **Special Tools**.
3. Place the **J 36352-6** on the output shaft (687). See **Special Tools**. Press on the **J 36352-6** until it contacts the **J 36352-4** in the window (the **J 36352-4** will be a positive stop for the **J 36352-6**).

OUTPUT SHAFT INSTALLATION

Tools Required

J 29837-A Output Shaft Support Fixture. See **Special Tools**.

Installation Procedure

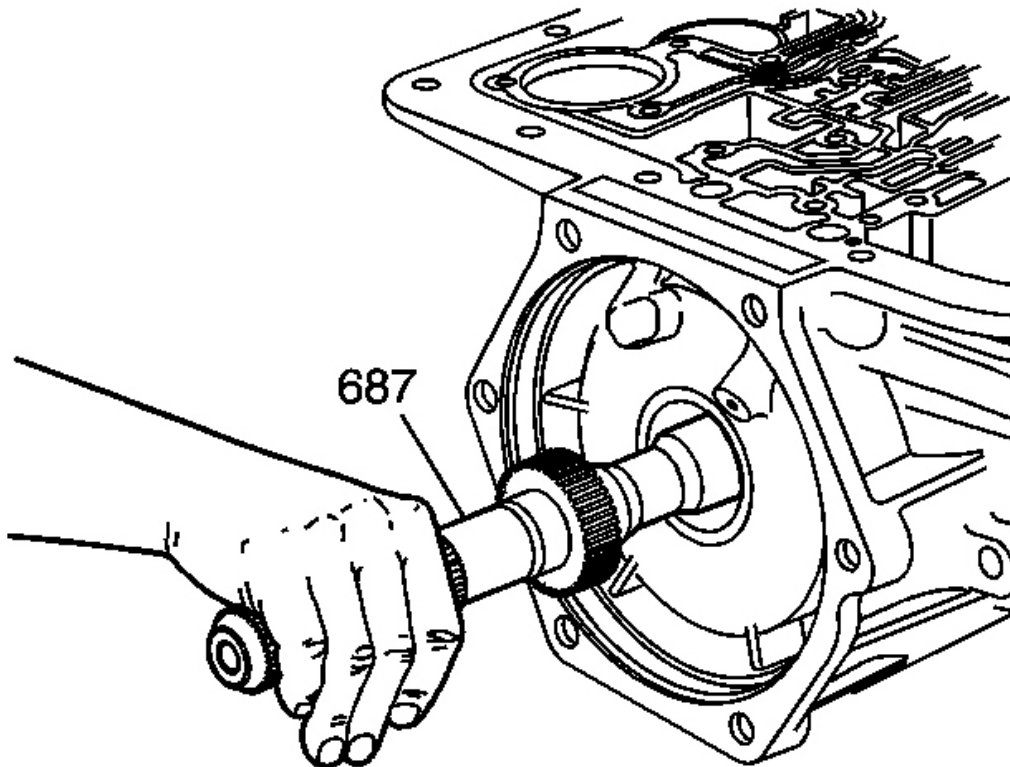

Fig. 299: View Of Output Shaft
Courtesy of GENERAL MOTORS CORP.

IMPORTANT: It is important to note that the input shaft may need a light tap to fully seat into position. If the input shaft is not completely engaged, the output shaft to input carrier retainer (661) will not seat.

1. Install the output shaft (687).

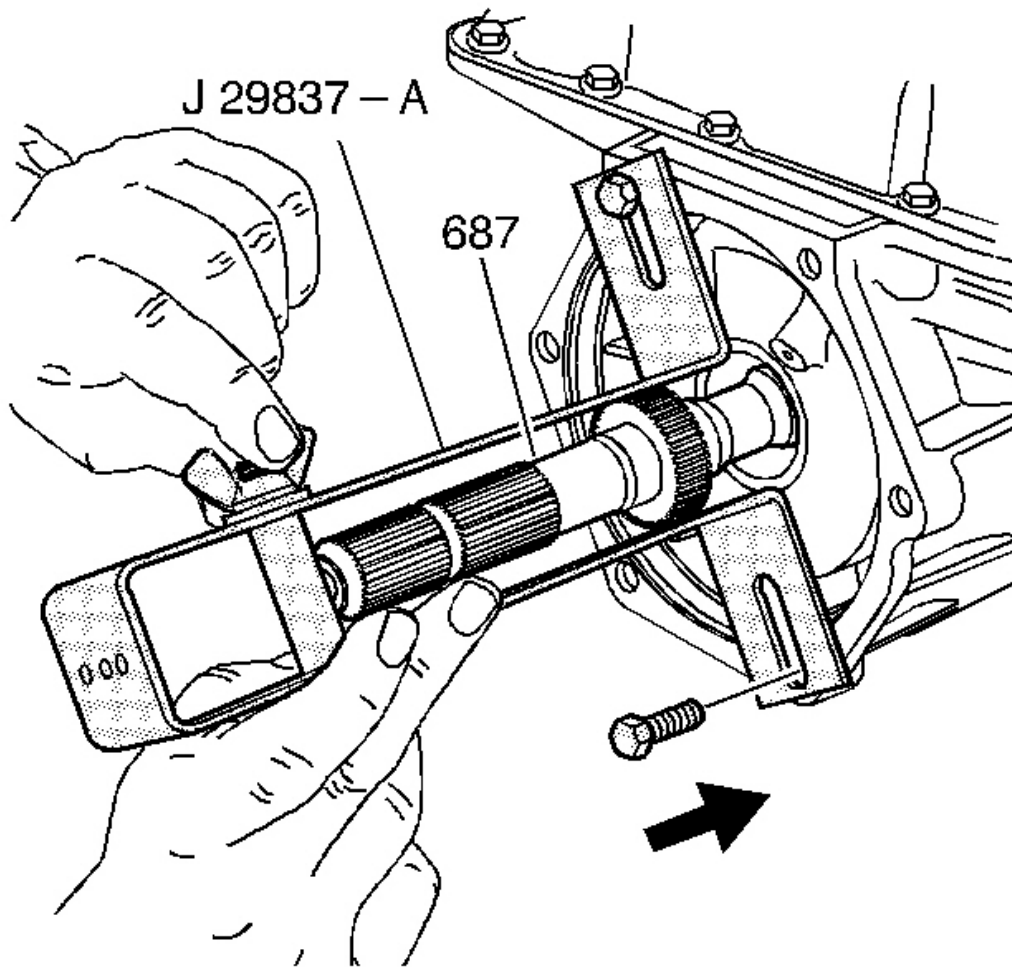

Fig. 300: Installing J 29837-A
Courtesy of GENERAL MOTORS CORP.

2. Install the J 29837-A . See Special Tools.

INPUT CARRIER INSPECTION

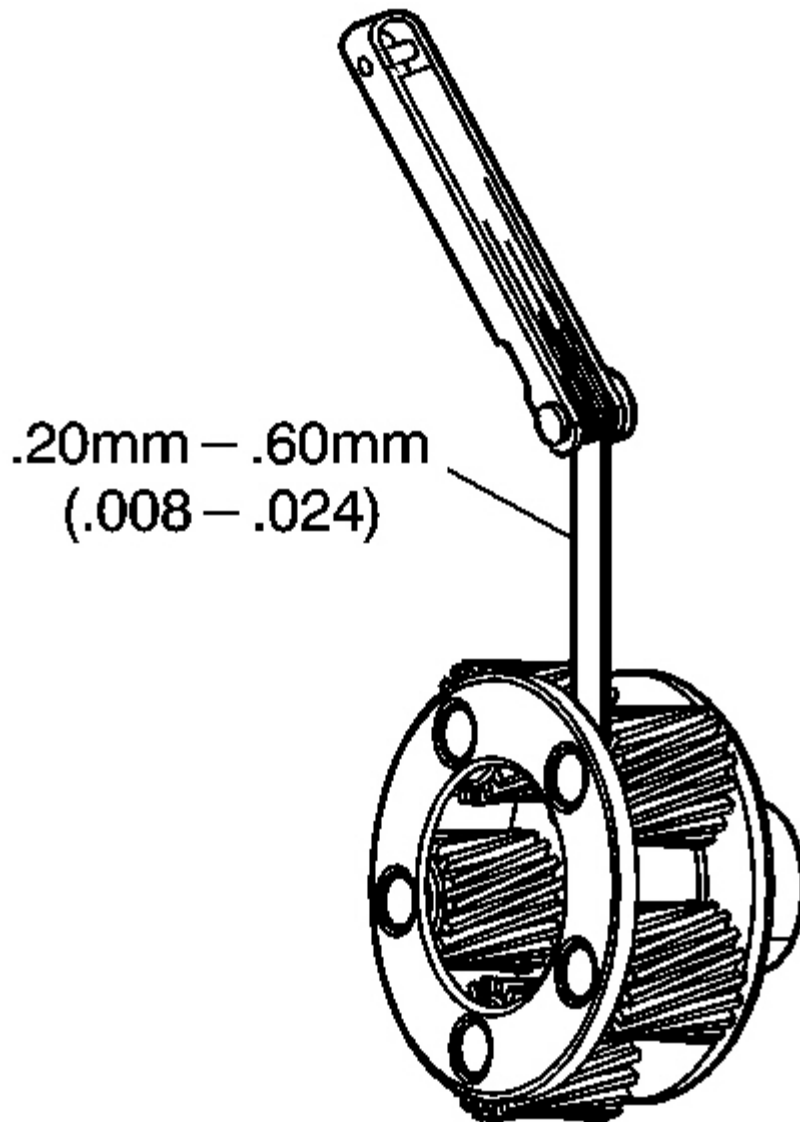

Fig. 301: Input Carrier Pinion End Play
Courtesy of GENERAL MOTORS CORP.

IMPORTANT: Check end play on each pinion.

2007 Hummer H3

2007 TRANSMISSION Automatic Transmission - 4L60-E/4L65-E/4L70-E - H3

1. Check the input carrier pinion end play. The end play must not exceed 0.61 mm (0.024 in).
2. Inspect the input carrier for pinion gear damage, proper pin stake and keystone pinion gears. Pinions must rotate freely.

INPUT SUN GEAR BUSHING REPLACEMENT

Tools Required

- **J 8092** Universal Driver Handle - 3/4 in - 10
- **J 34196-B** Transmission Bushing Service Set. See **Special Tools**.

Removal Procedure

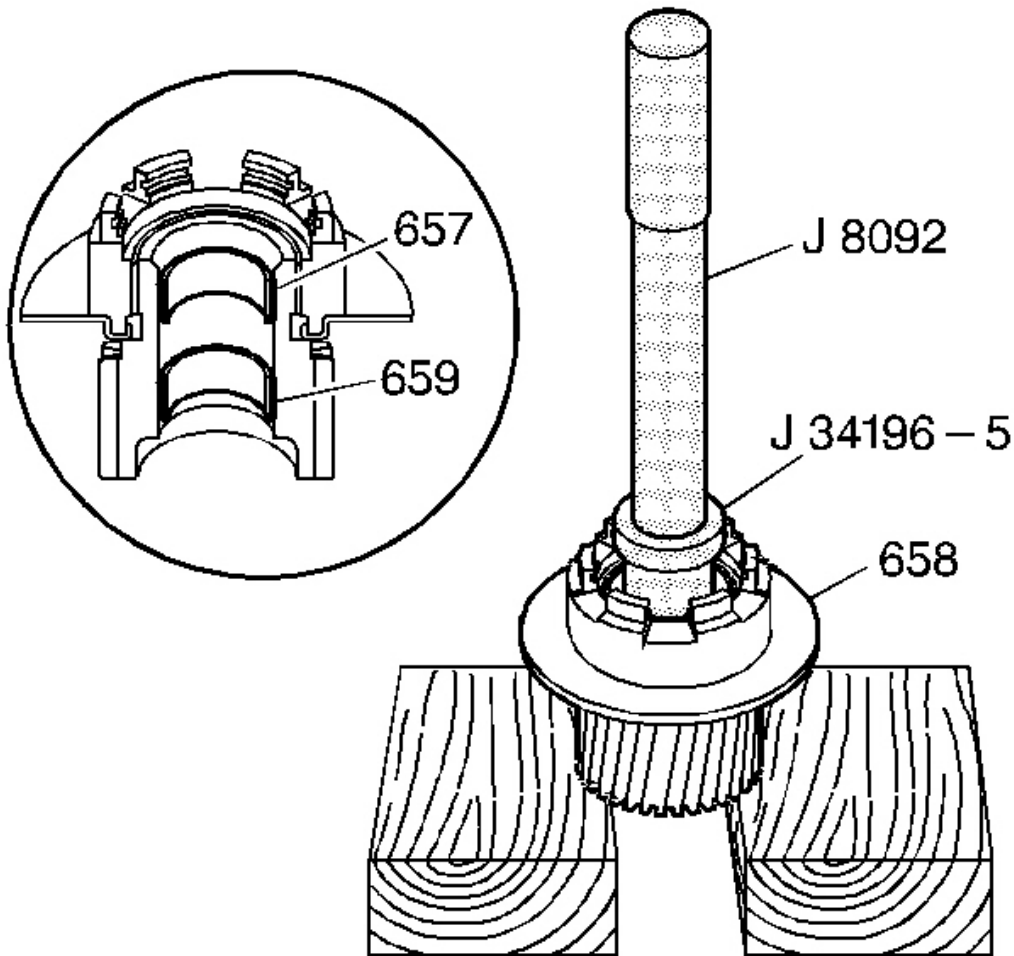

Fig. 302: Removing Input Sun Gear Front Bushing
Courtesy of GENERAL MOTORS CORP.

Using J 34196-5 which is part of kit J 34196-B with J 8092 , remove the input sun gear front bushing (657) and rear bushing (659). See **Special Tools**.

Installation Procedure

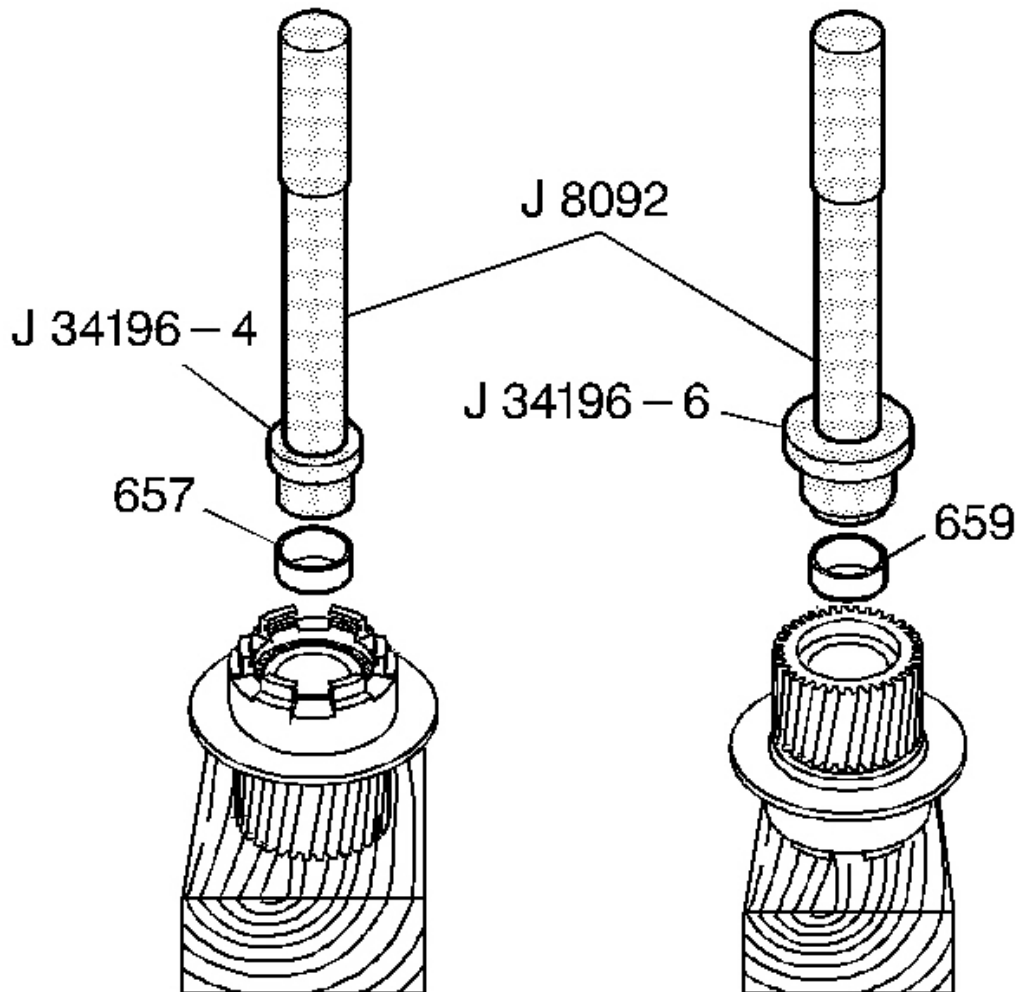

Fig. 303: Installing Input Sun Gear Front Bushing
Courtesy of GENERAL MOTORS CORP.

1. Using J 34196-4 which is part of kit J 34196-B with J 8092 , install the input sun gear front bushing (657). See **Special Tools**.
2. Using J 34196-6 which is part of kit J 34196-B with J 8092 , install the input sun gear rear bushing (659). See **Special Tools**.

INPUT CARRIER INSPECTION AND INSTALLATION

Tool Required

J 36850 Transjcl Lubricant

Inspection & Installation Procedure

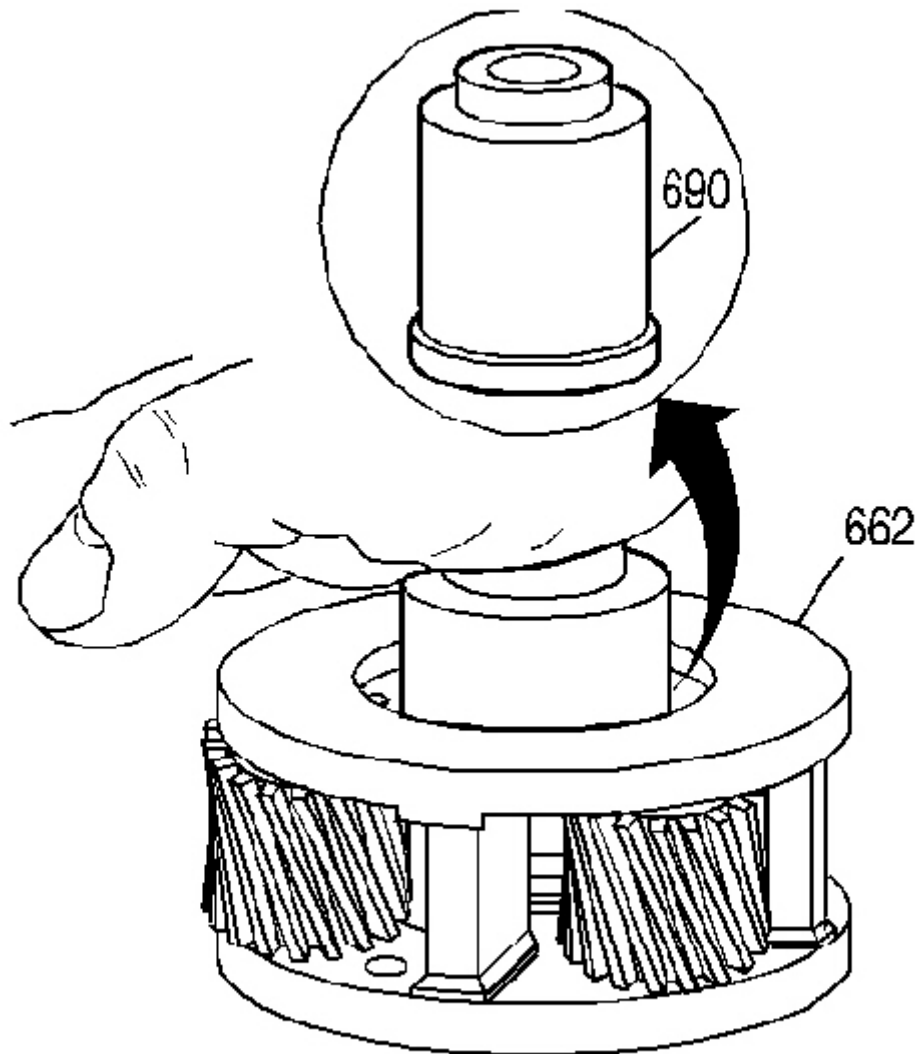

Fig. 304: View Of Input Carrier Captive Thrust Bearing Assembly
Courtesy of GENERAL MOTORS CORP.

1. Inspect the input carrier captive thrust bearing assembly. To check the captive thrust bearing

in the input carrier (662) for wear, place a bushing or an output shaft sleeve (690) onto the bearing race and turn it with the palm of your hand. Do not touch the pinion gears. Any imperfections will be felt through the bushing.

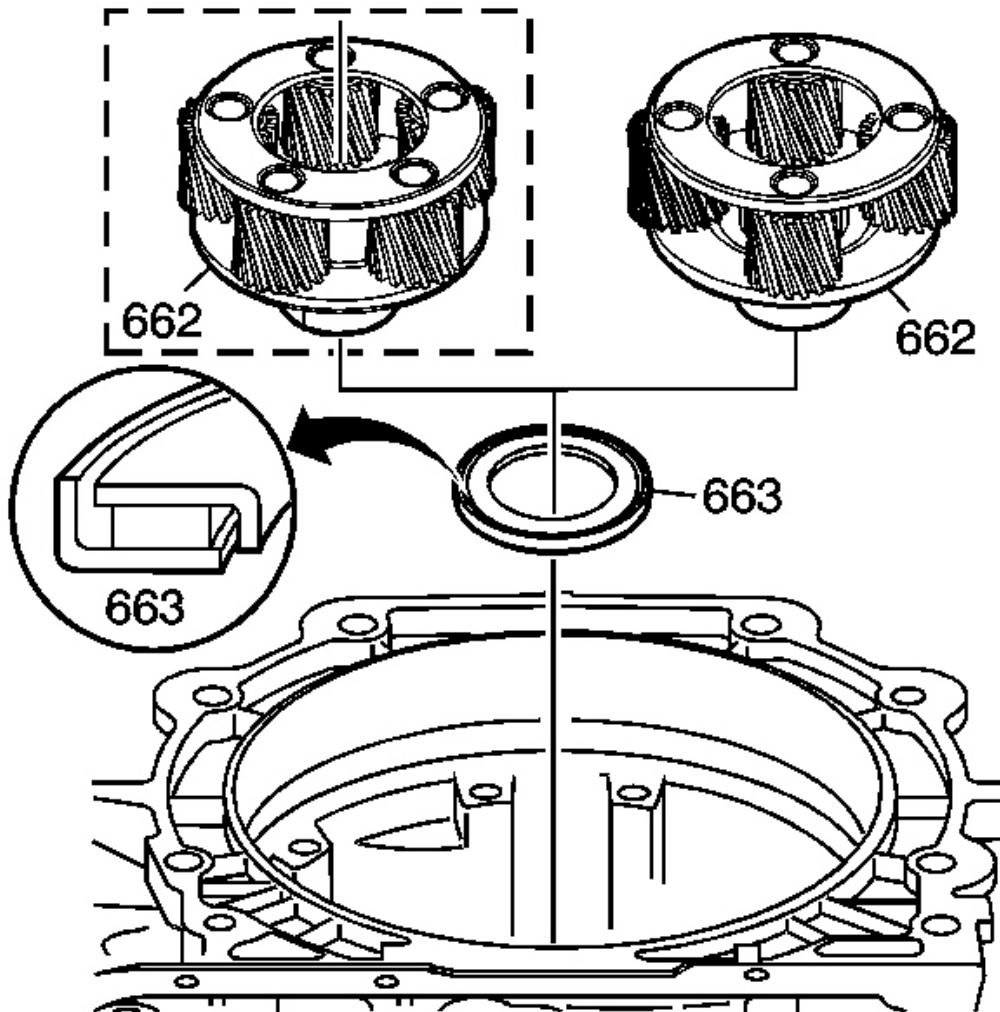

Fig. 305: View Of Bearing Assembly & Input Carrier
Courtesy of GENERAL MOTORS CORP.

2. Install the thrust bearing assembly (663) on the input carrier (662). Retain bearing with **J 36850**.
3. Install the input carrier assembly (662) onto the output shaft. The carrier assembly can be

either a 4 or 5 pinion design, depending on model.

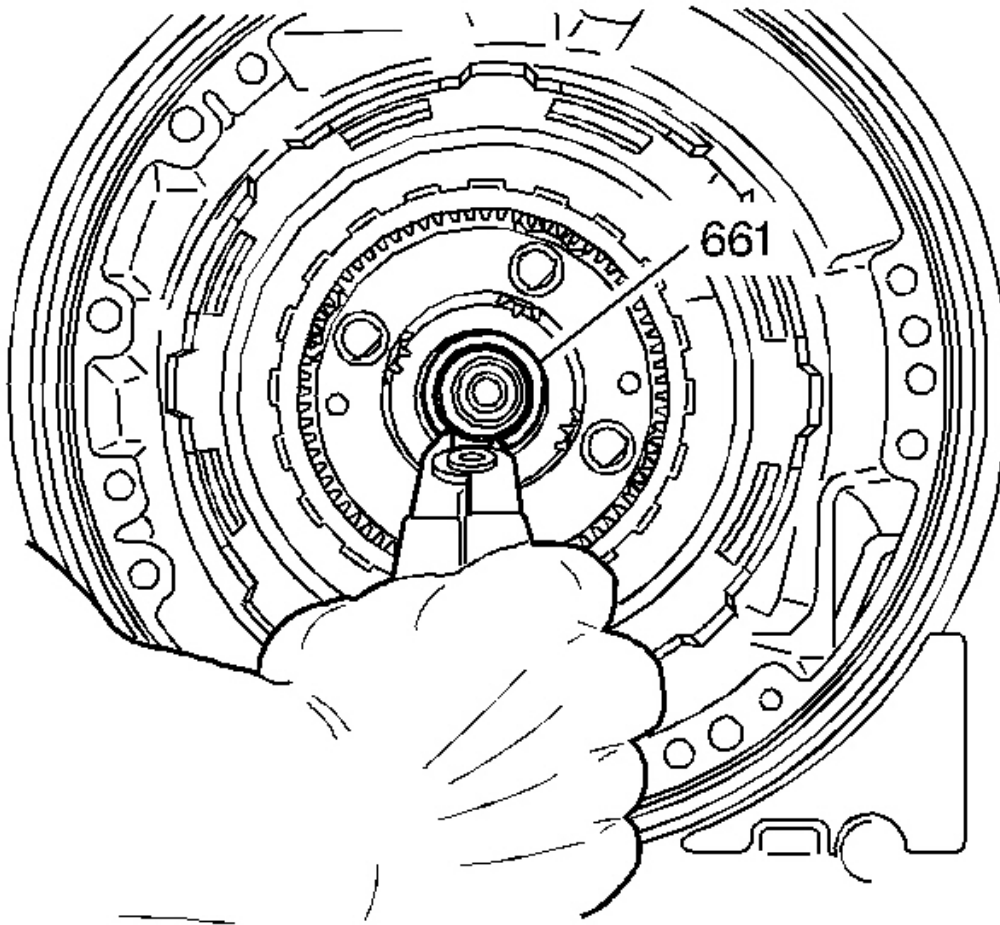

Fig. 306: View Of Output Shaft To Input Carrier Retainer
Courtesy of GENERAL MOTORS CORP.

IMPORTANT:

- Do not reuse the old output shaft to input carrier retainer (661).
- Do not over expand the new output shaft to input carrier retainer during installation.

4. Install a new output shaft to input carrier retainer (661).

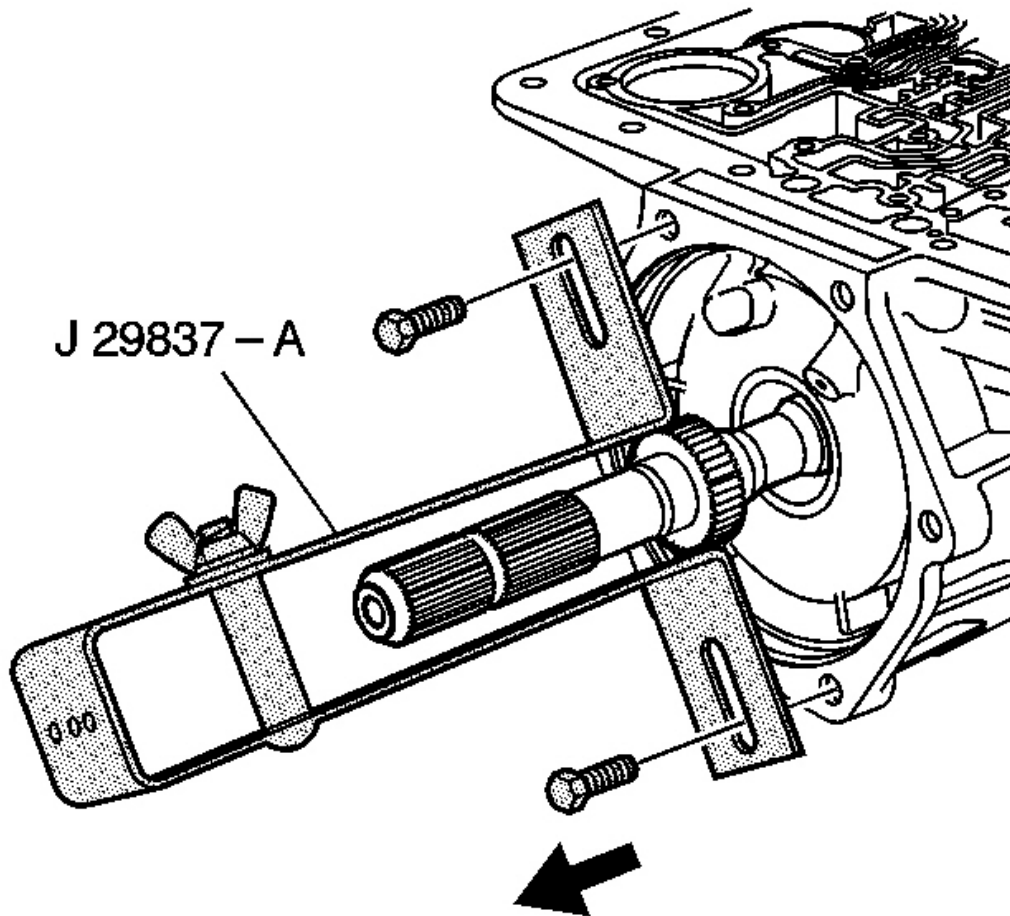

Fig. 307: Identifying J 29837-A
Courtesy of GENERAL MOTORS CORP.

5. Remove the **J 29837-A** . See **Special Tools**.

INPUT CLUTCH ASSEMBLY DISASSEMBLE

Tools Required

- **J 23327-1** Forward Clutch Spring Compressor (Bridge). See **Special Tools**.
- **J 23456** Booster and Clutch Pack Compressor. See **Special Tools**.
- **J 25018-A** Clutch Spring Compressor Adapter. See **Special Tools**.

Disassembly Procedure

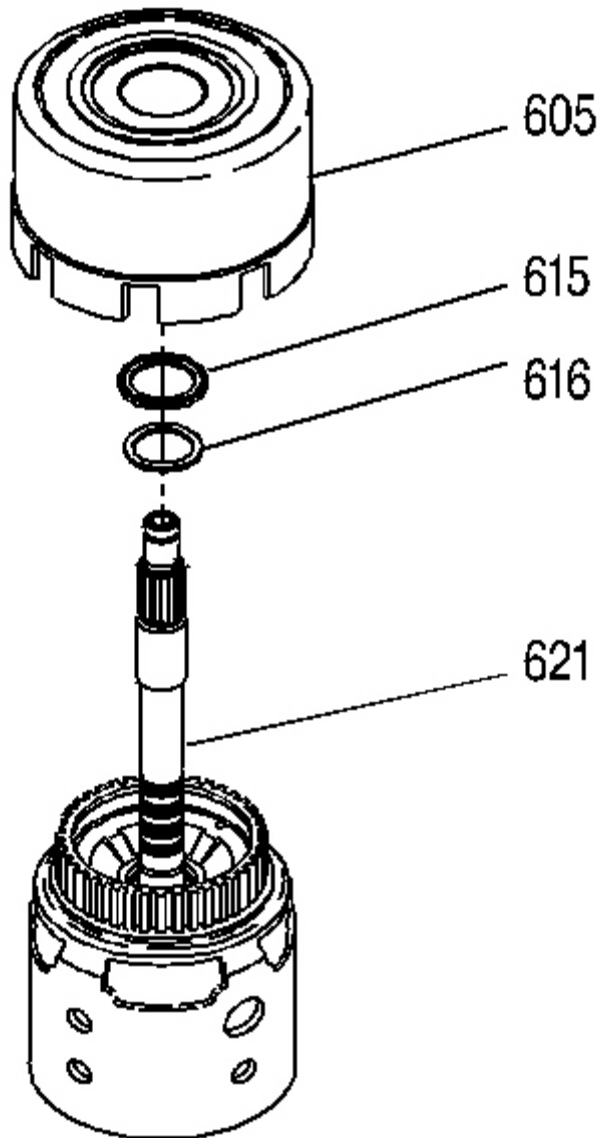

Fig. 308: View Of Stator Shaft/Selective Washer Bearing Assembly
Courtesy of GENERAL MOTORS CORP.

1. Remove the reverse input clutch housing and drum assembly (605) from the input clutch

assembly (621).

2. Remove the stator shaft/selective washer bearing assembly (615).
3. Remove the selective thrust washer (616).

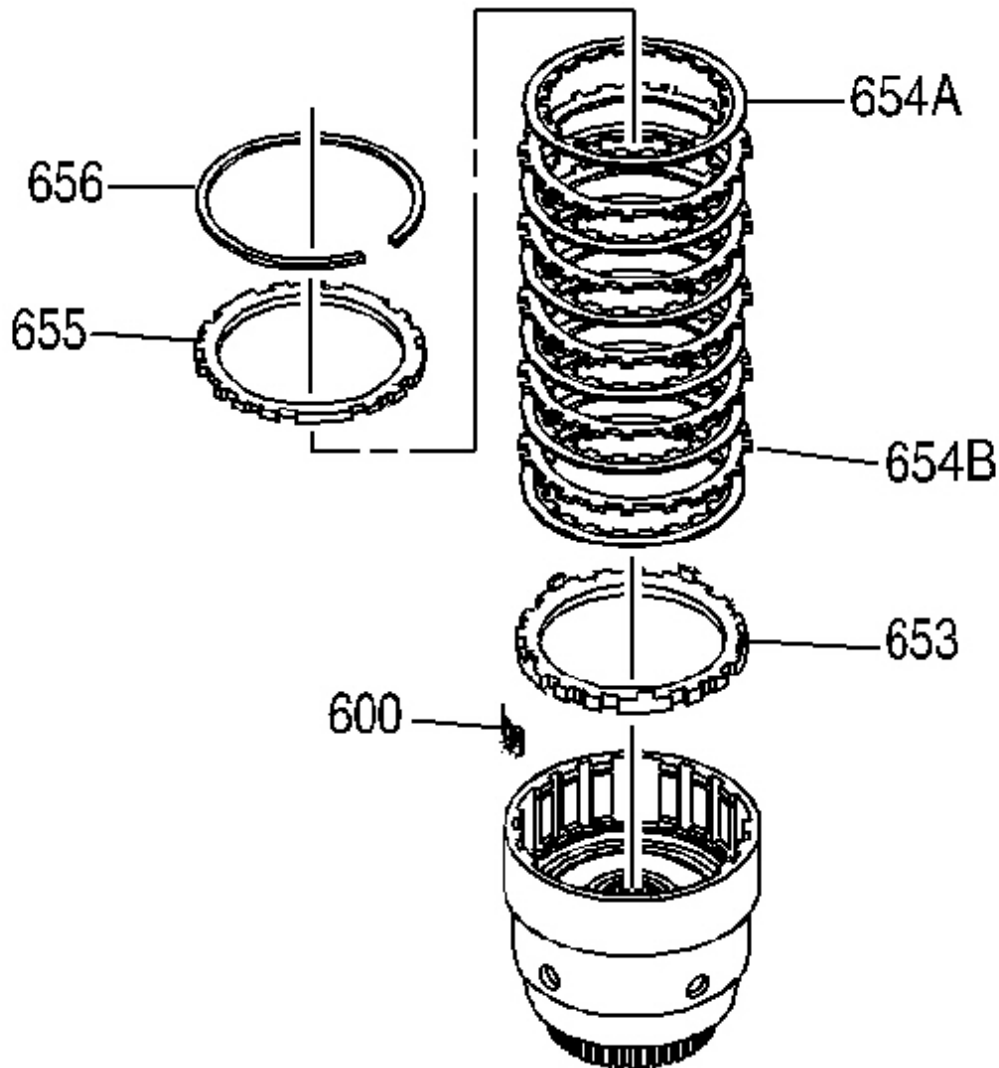

Fig. 309: Locating 3rd & 4th Clutch Backing Plate Retainer Ring
Courtesy of GENERAL MOTORS CORP.

2007 Hummer H3

2007 TRANSMISSION Automatic Transmission - 4L60-E/4L65-E/4L70-E - H3

4. Remove the 3rd and 4th clutch backing plate retainer ring (656).

NOTE: The correct number of fiber plates must be used to avoid damage to the transmission. An incorrect stack up height can cause either excessive clutch slippage or insufficient release, resulting in burned clutch plates.

IMPORTANT: The 3rd and 4th clutch plate stack is model specific. Clutch plate stack up could be either 6 or 7 plates.

5. Remove all 3rd and 4th clutch plates (653-655).
6. Remove the 3-4 clutch boost spring assemblies (600).

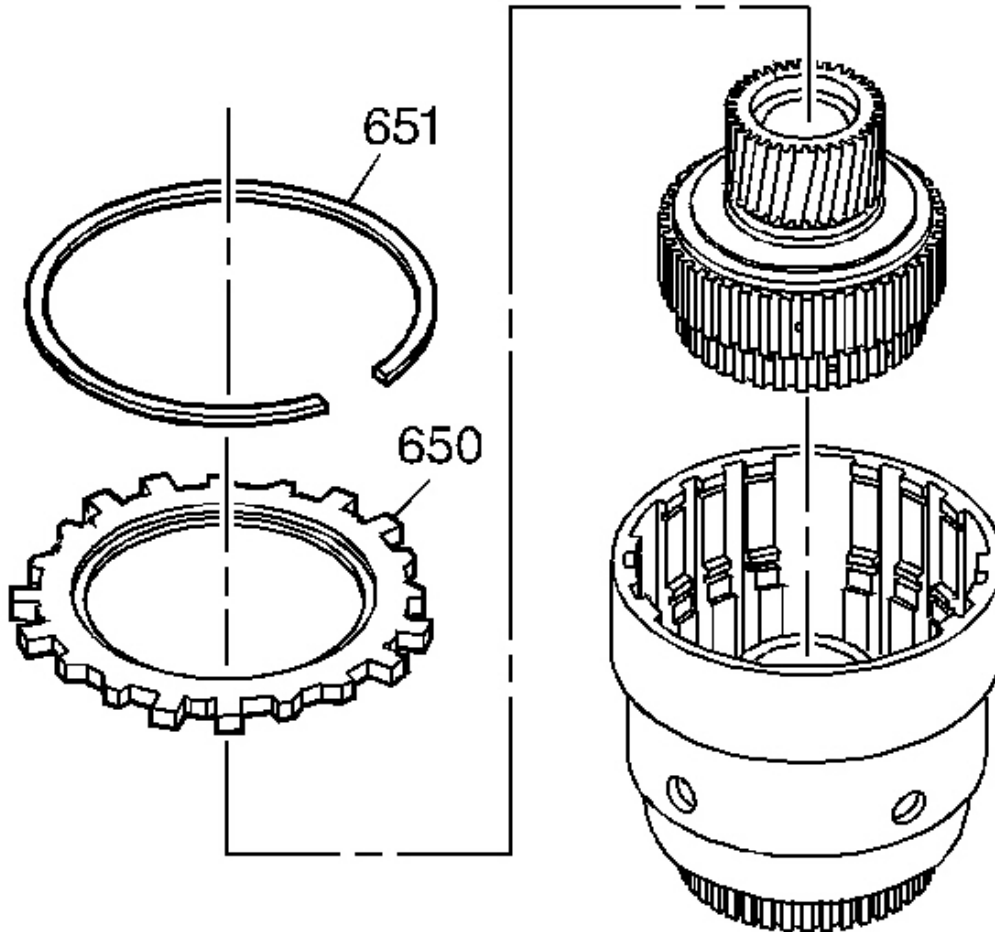

Fig. 310: Identifying Forward Clutch Selective Backing Plate & Retainer Ring
Courtesy of GENERAL MOTORS CORP.

7. Remove the forward clutch backing plate retainer ring (651).
8. Remove the forward clutch selective backing plate (650).
9. Remove the forward clutch sprag assembly.

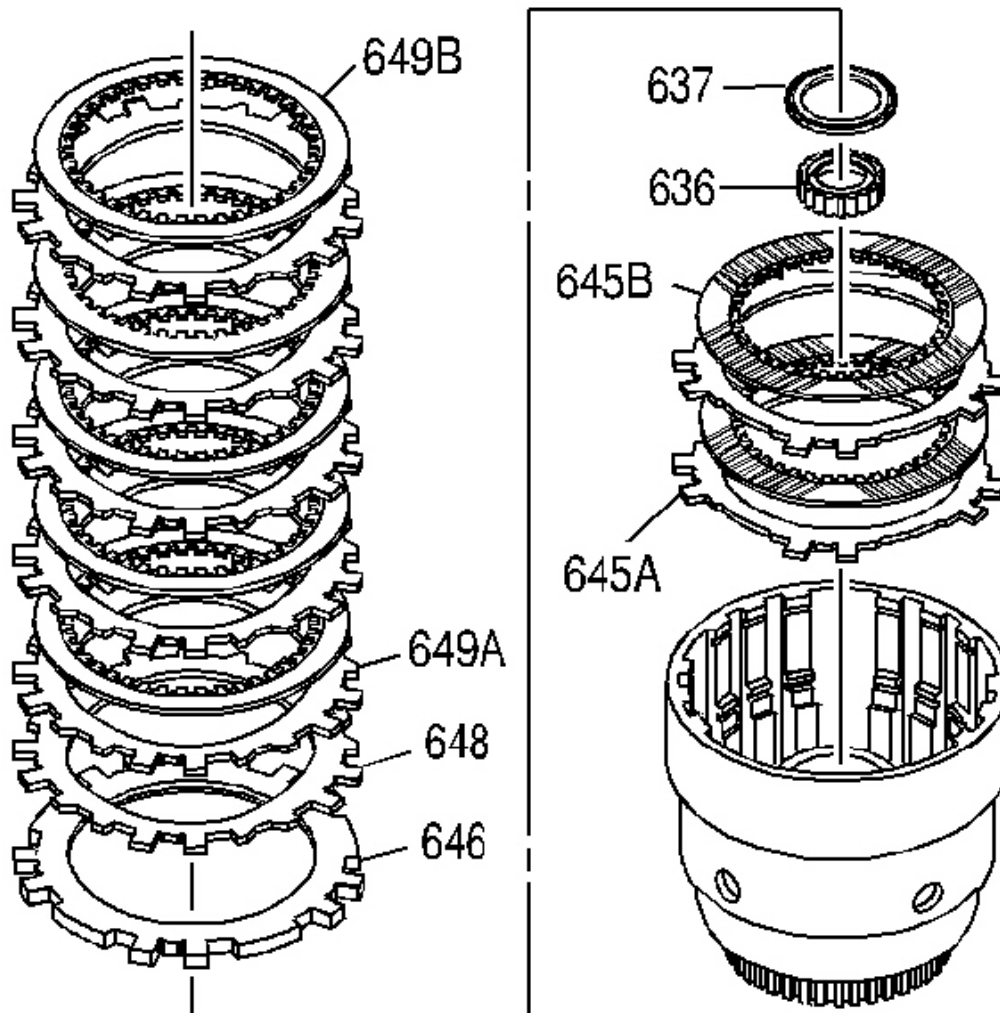

Fig. 311: View Of Forward Clutch Plates
 Courtesy of GENERAL MOTORS CORP.

10. Remove all forward clutch plates (646, 648, 649A, 649B).
11. Remove the input sun gear bearing assembly (637).
12. Remove the input housing to output shaft seal (636).
13. Remove all overrun clutch plates (645A, 645B).

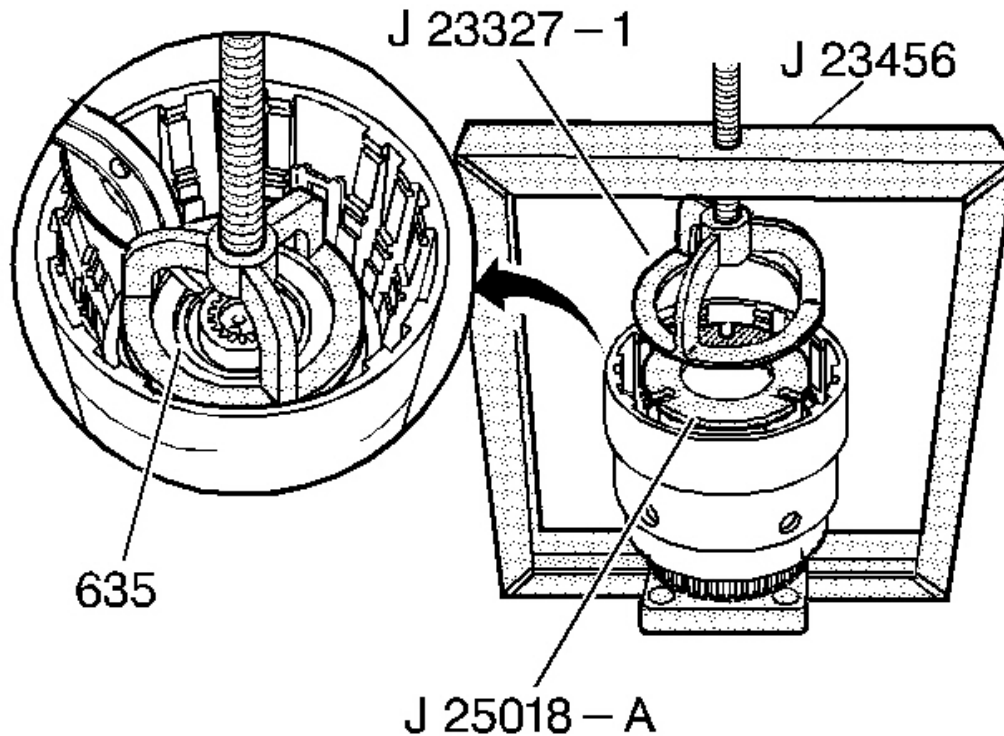

Fig. 312: Installing J 23327-1 & J 25018-A
Courtesy of GENERAL MOTORS CORP.

14. Install the **J 23327-1** and the **J 25018-A** . See **Special Tools**.
15. Compress the overrun clutch spring, using the **J 23456** . See **Special Tools**.
16. Remove the overrun clutch spring retainer snap ring (635).
17. Remove the **J 23327-1** and the **J 25018-A** . See **Special Tools**.

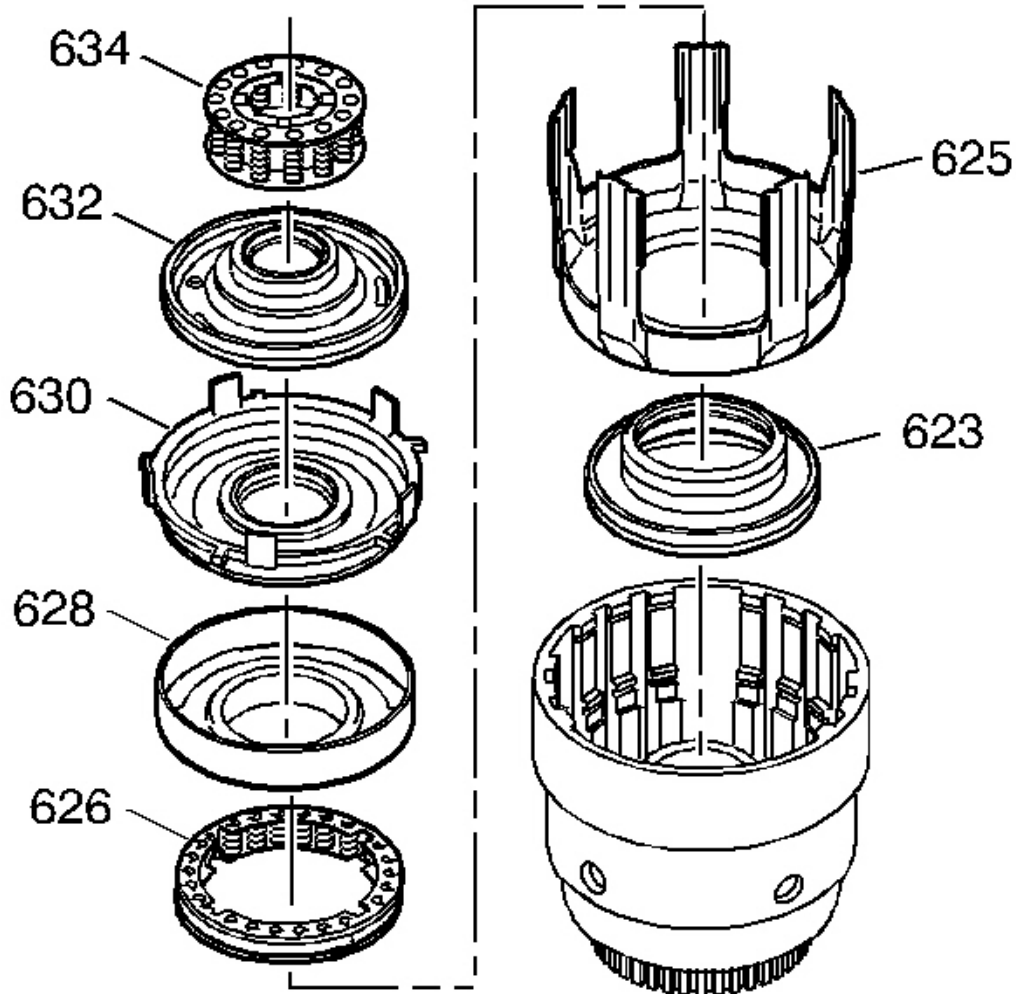

Fig. 313: Input Clutch Assembly
 Courtesy of GENERAL MOTORS CORP.

18. Remove the overrun clutch spring assembly (634).
19. Remove the overrun clutch piston (632).
20. Remove the forward clutch piston (630).
21. Remove the forward clutch housing (628).
22. Remove the 3rd and 4th clutch spring assembly (626).
23. Remove the 3rd and 4th clutch apply ring (625).

24. Remove the 3rd and 4th clutch piston (623).

INPUT HOUSING AND SHAFT ASSEMBLY INSPECTION

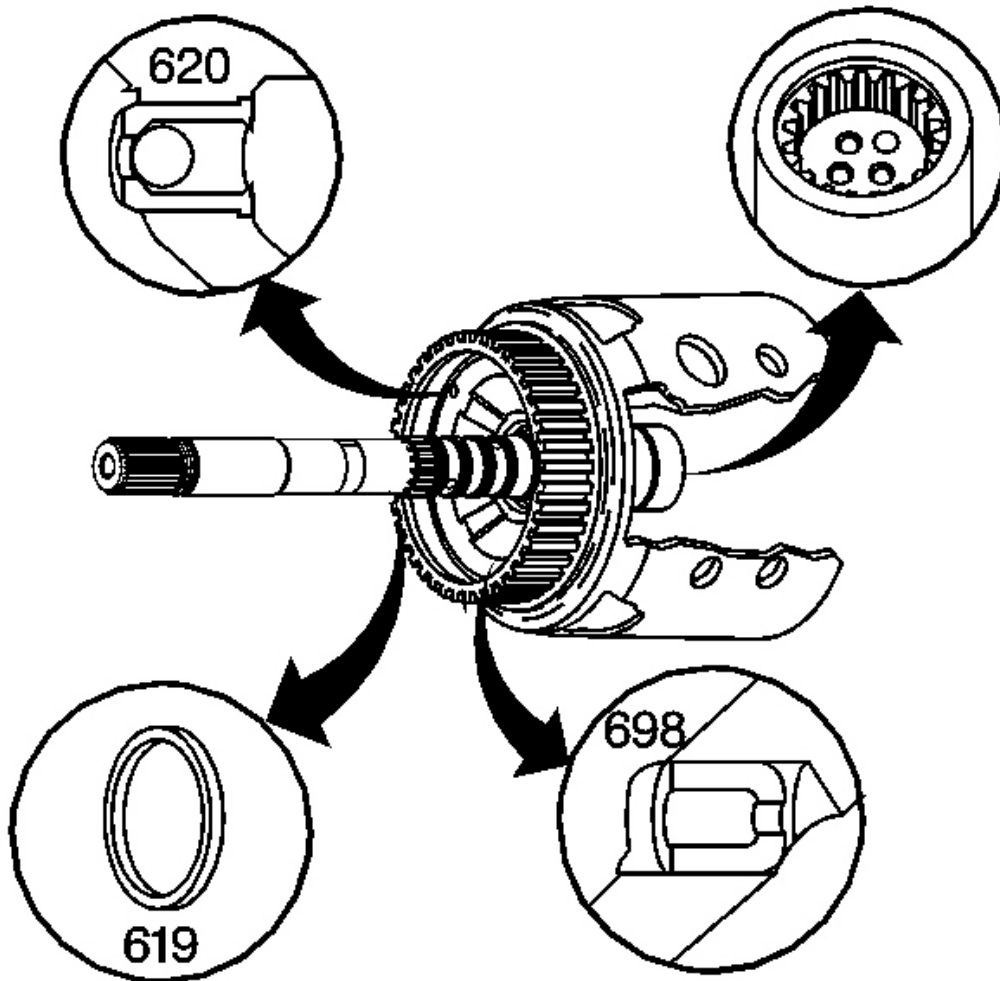

Fig. 314: Identifying Input Housing & Shaft Assembly
Courtesy of GENERAL MOTORS CORP.

1. Inspect the input housing and shaft assembly for the following conditions:
 - Porosity
 - Spline wear - internal and external

- Input speed sensor models, rotor teeth for cracks or damage
 - Three turbine shaft ball check valves are present and move freely
 - Retainer and ball check valve assembly (620)
 - Orificed cup plug (698)
 - Lube hole cracks
2. Test the input housing for cracks by tapping housing with wooden handle. Housing should produce a sharp ring.
 3. Inspect the turbine shaft oil seal ring (619) grooves for damage or burrs. The oil seal rings (619) must fit loose into the ring grooves.

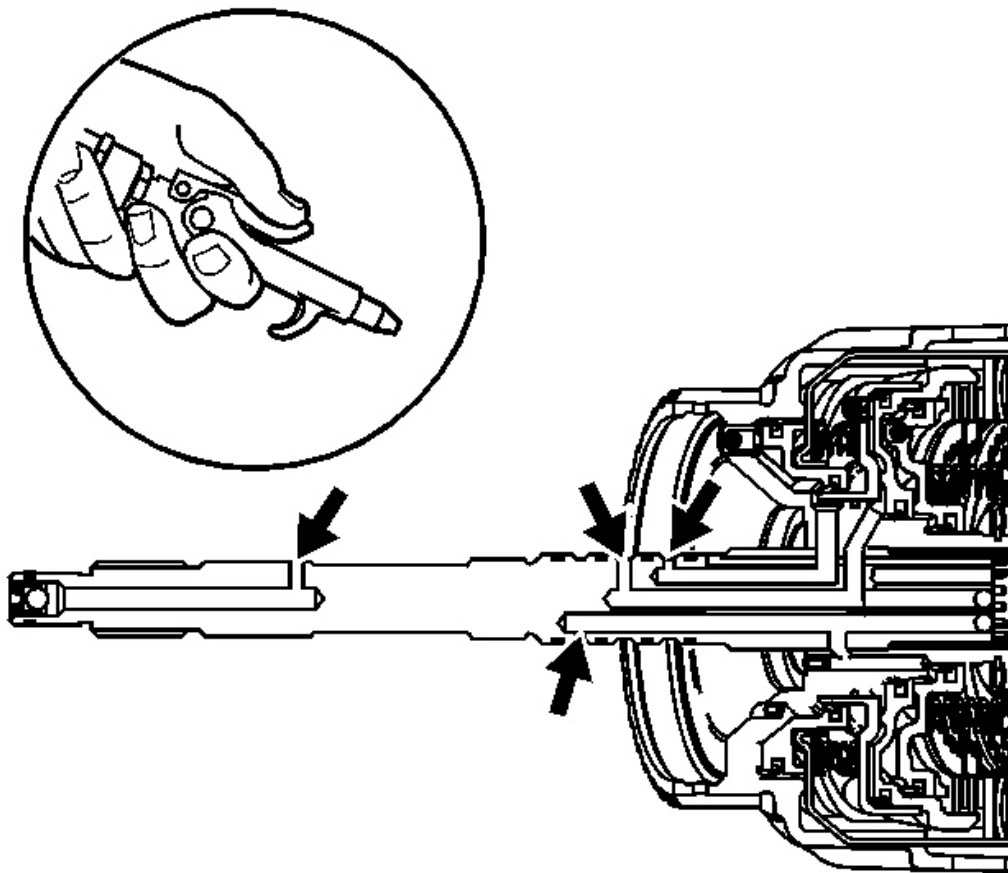

Fig. 315: Identifying Oil Feed Passages
Courtesy of GENERAL MOTORS CORP.

2007 Hummer H3

2007 TRANSMISSION Automatic Transmission - 4L60-E/4L65-E/4L70-E - H3

4. Inspect the oil feed passages for obstructions.
5. Apply compressed air into the passages indicated.

INPUT HOUSING AND SHAFT ASSEMBLY ASSEMBLE

Tools Required

- **J 23327-1** Forward Clutch Spring Compressor (Bridge). See **Special Tools**.
- **J 23456** Booster and Clutch Pack Compressor. See **Special Tools**.
- **J 25018-A** Clutch Spring Compressor Adapter. See **Special Tools**.
- **J 26744-A** Seal Installer. See **Special Tools**.
- **J 29882** Overrun Clutch Seal Protector. See **Special Tools**.
- **J 29883** Forward Clutch Seal Protector. See **Special Tools**.

Assembly Procedure

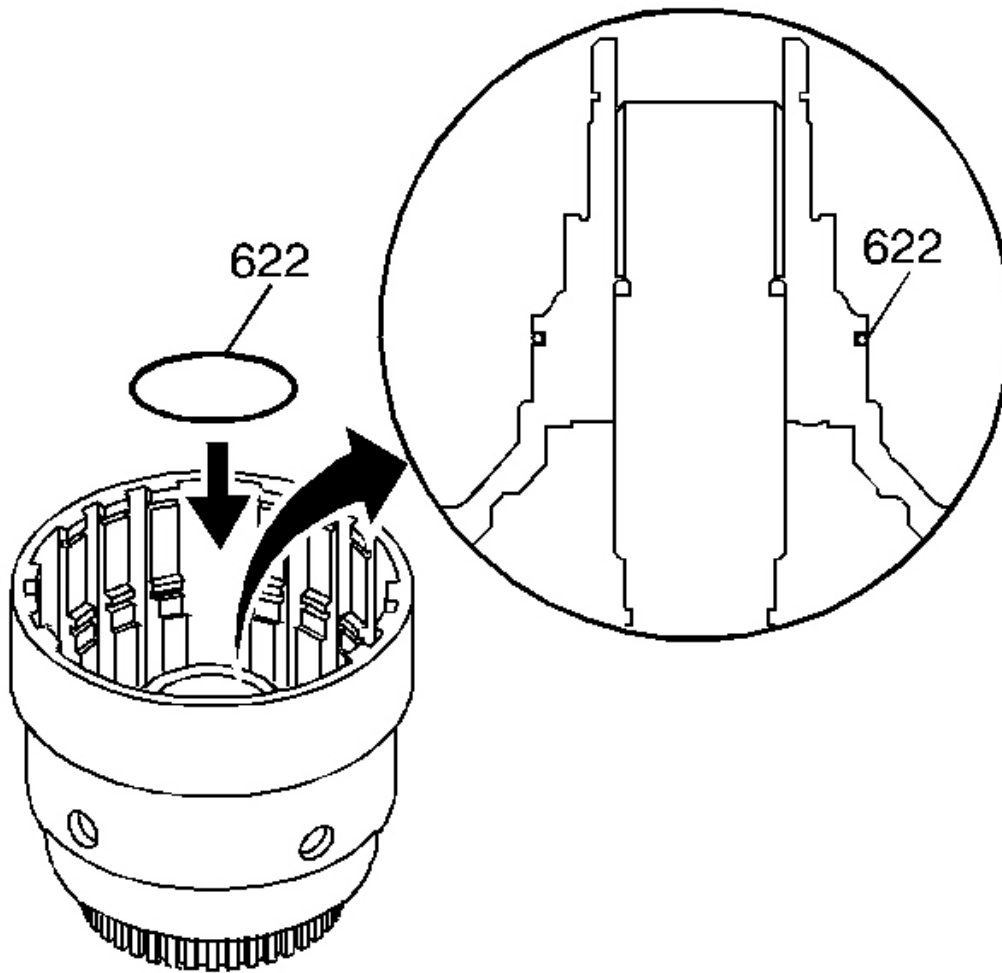

Fig. 316: Locating Forward Clutch Housing O-Ring Seal
Courtesy of GENERAL MOTORS CORP.

1. Install a new input to forward clutch housing O-ring seal (622).

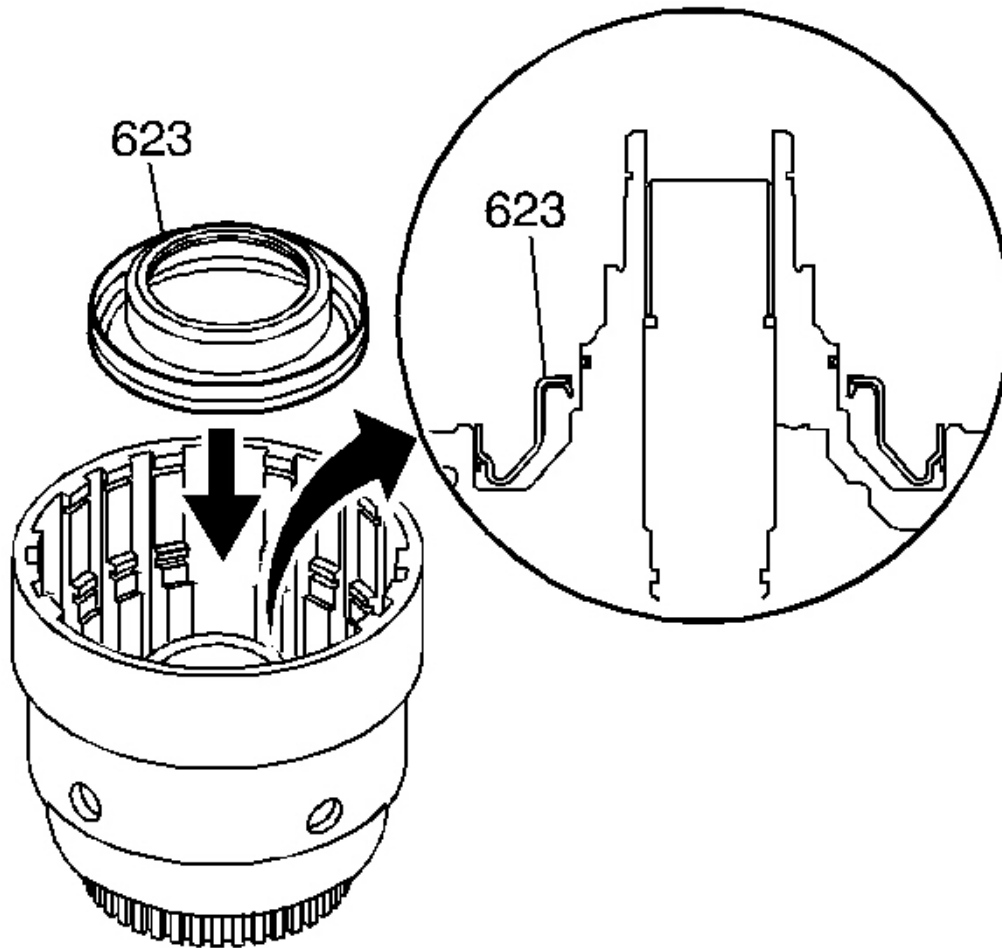

Fig. 317: Identifying 3rd & 4th Clutch Piston Inspection Areas
Courtesy of GENERAL MOTORS CORP.

2. Inspect the 3rd and 4th clutch piston (623) for the following conditions:
 - Porosity or damage
 - Seal damage
3. Install the 3rd and 4th clutch piston (623) into the input housing.

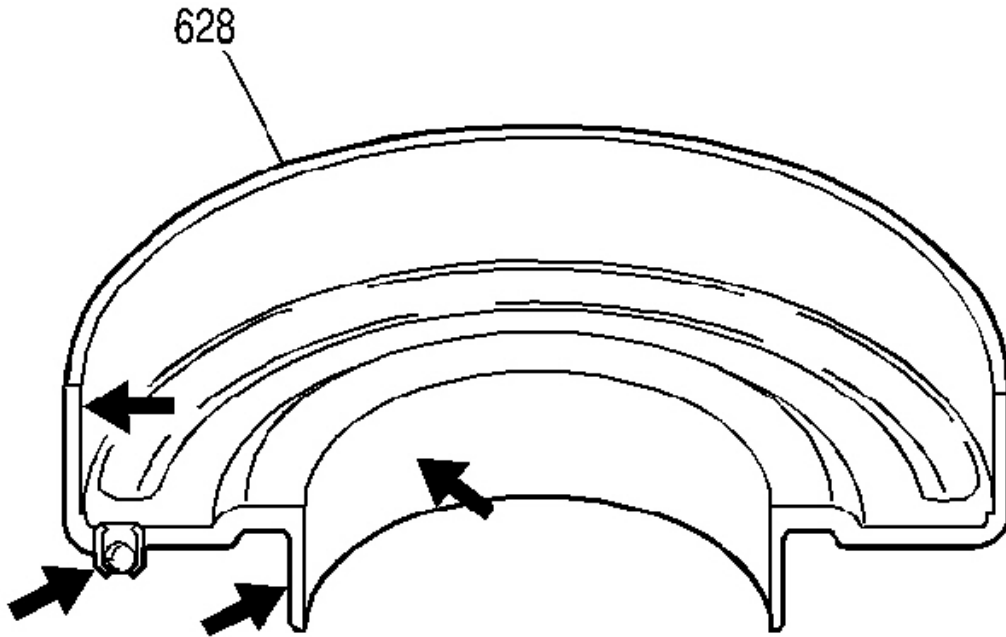

Fig. 318: Forward Clutch Housing Inspection Areas
Courtesy of GENERAL MOTORS CORP.

4. Inspect the forward clutch housing (628) for the following conditions:
 - Proper check ball operation
 - Damage or distortion
 - Burrs in the seal areas
 - Cracks

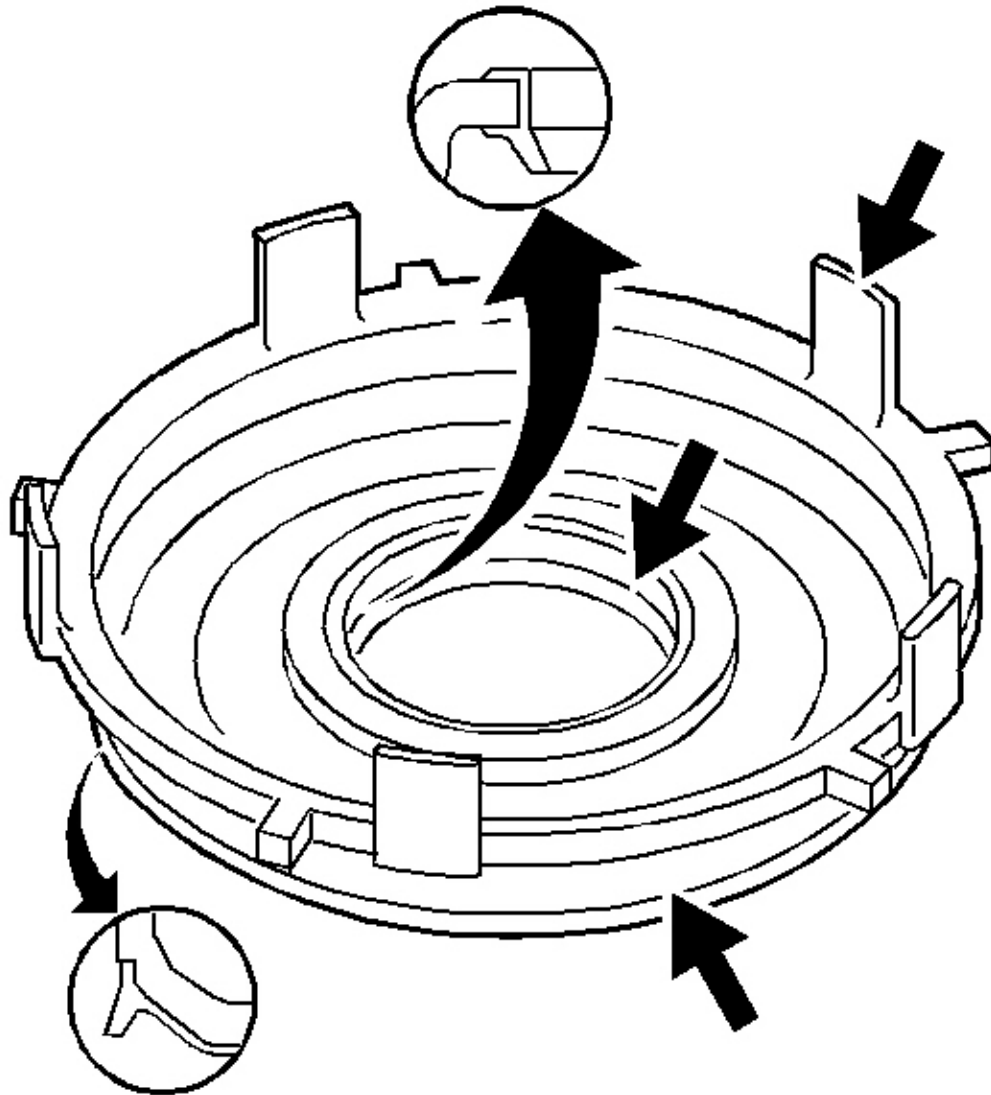

Fig. 319: Inspecting Forward Clutch Piston For Damage Or Wear
Courtesy of GENERAL MOTORS CORP.

5. Inspect the forward clutch piston for the following conditions:
 - Porosity or damage
 - Seal damage
 - Apply leg damage

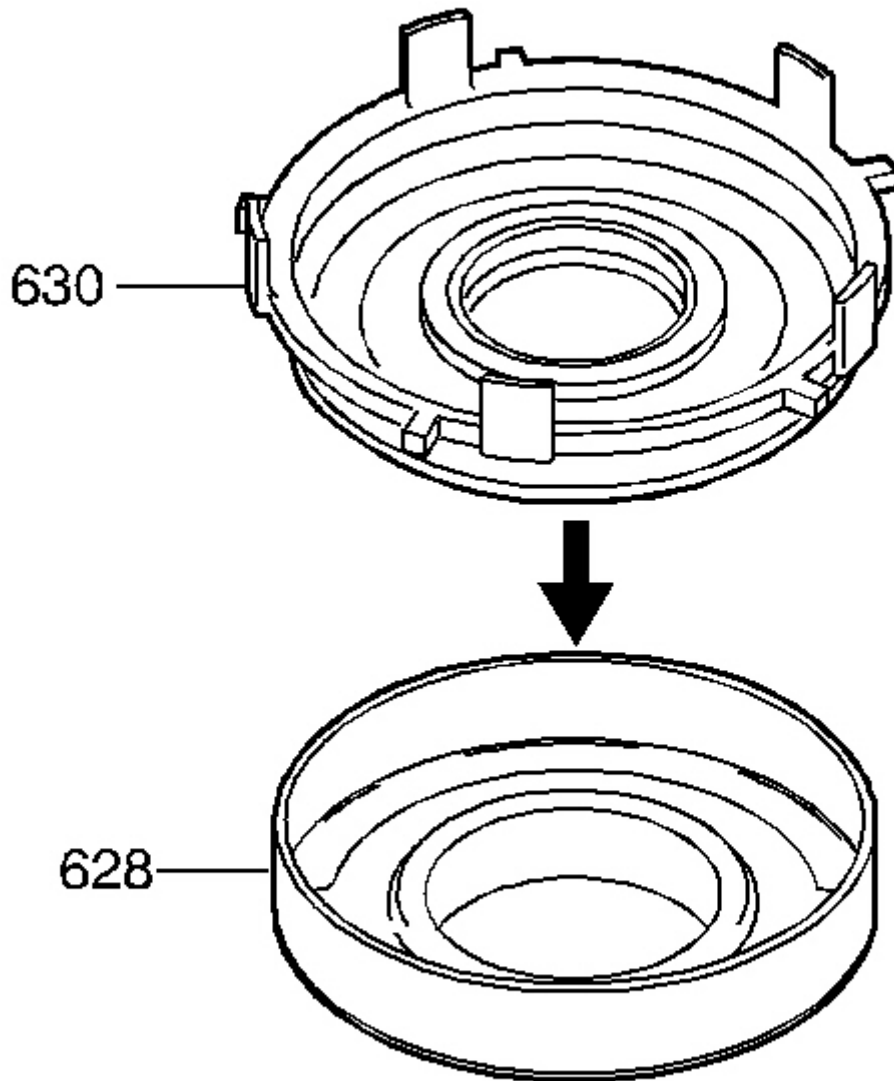

Fig. 320: Installing Forward Clutch Piston
Courtesy of GENERAL MOTORS CORP.

6. Install the forward clutch piston (630) into the forward clutch housing (628).

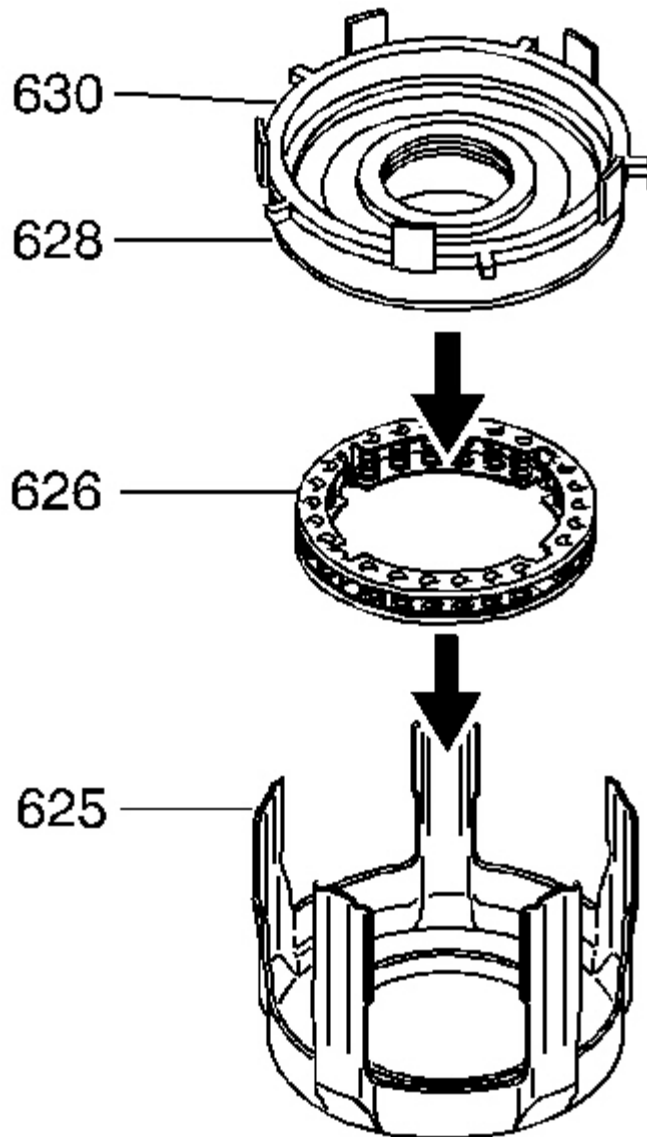

Fig. 321: Locating 3rd & 4th Spring Assembly
Courtesy of GENERAL MOTORS CORP.

7. Install the 3rd and 4th spring assembly (626) into the 3rd and 4th clutch apply ring (625).

IMPORTANT: The forward clutch piston (630) apply legs must be indexed

with the 3rd and 4th clutch apply ring (625) legs.

8. Install the forward clutch housing (628) and forward clutch piston (630) into the 3rd and 4th apply ring (625).

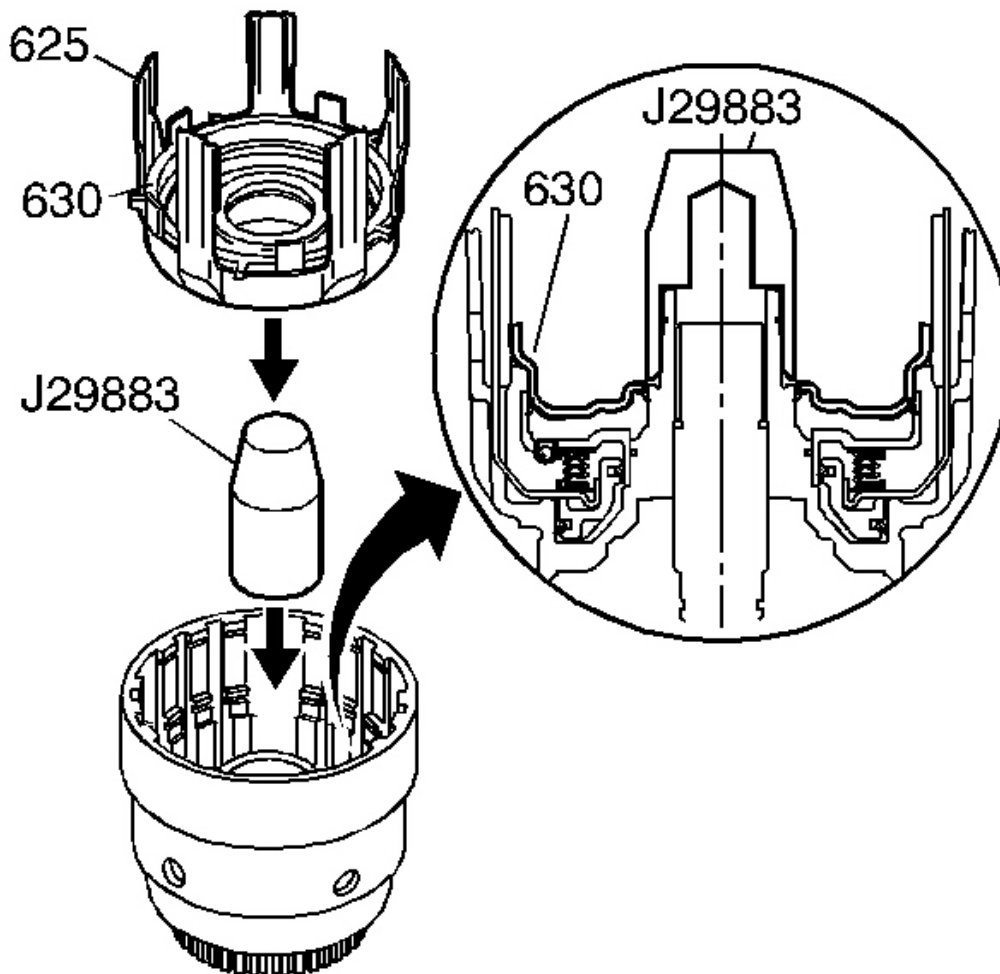

Fig. 322: View Of J 29883 Installed In Input Housing
Courtesy of GENERAL MOTORS CORP.

9. Install the **J 29883** on the input housing. See **Special Tools**.
10. Install the 3rd and 4th clutch apply ring and the forward housing and piston assembly using the following procedure:

- Hold the assembly by the 3rd and 4th clutch apply ring (625) legs during installation.
- Do not let the forward clutch piston (630) separate from the forward clutch housing.
- Firmly seat the assembly.

11. Remove the **J 29883** from the input housing. See **Special Tools**.

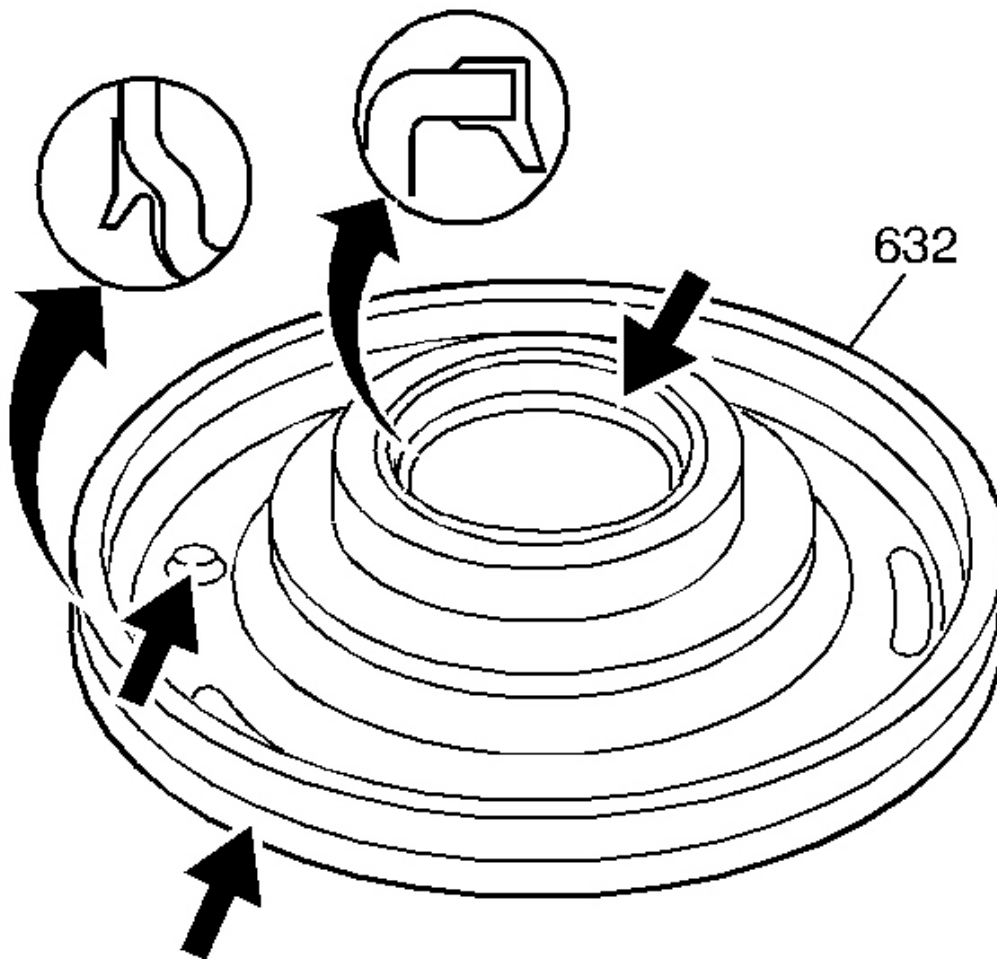

Fig. 323: Inspection Areas On Overrun Clutch Piston
Courtesy of GENERAL MOTORS CORP.

12. Inspect the overrun clutch piston (632) for the following conditions:
- Porosity or damage

- Seal damage
- Overrun clutch ball proper operation

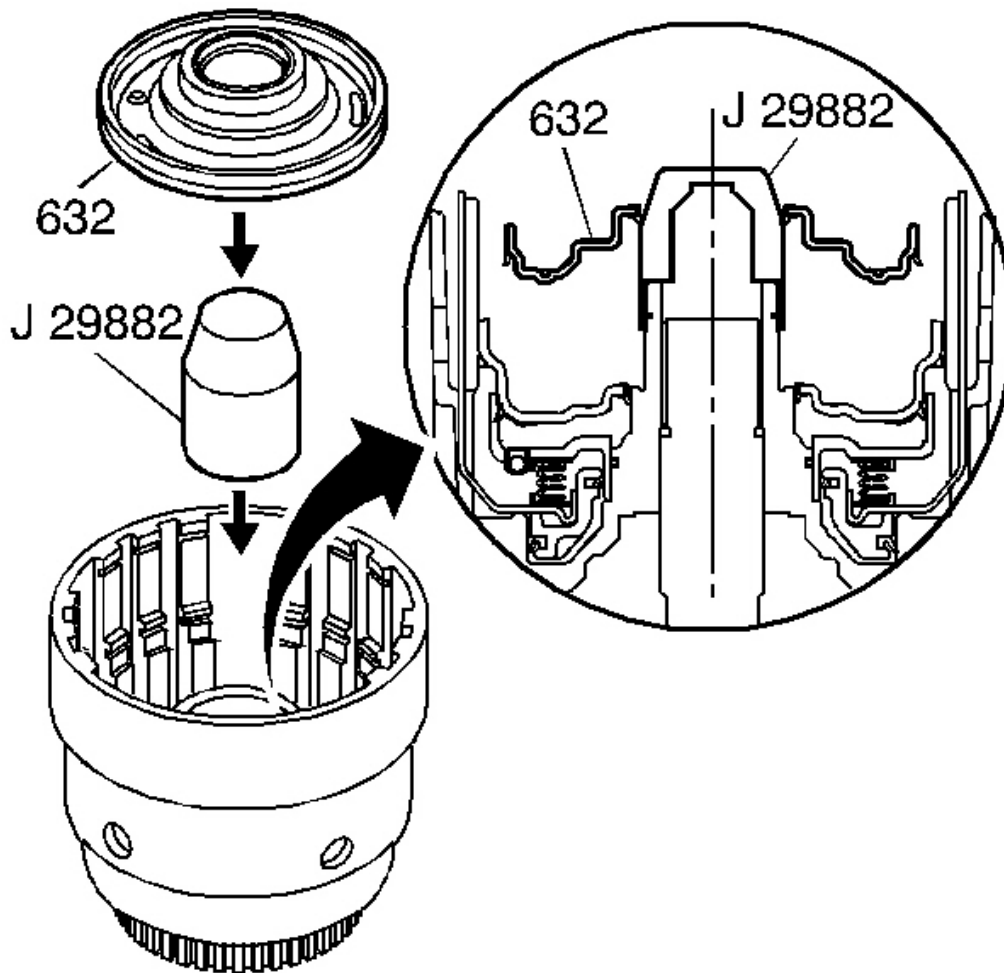

Fig. 324: Identifying Overrun Clutch Piston
Courtesy of GENERAL MOTORS CORP.

13. Install the **J 29882** on the input housing. See **Special Tools**.
14. Install the overrun clutch piston (632) into the input housing.
15. Remove the **J 29882** from the input housing. See **Special Tools**.

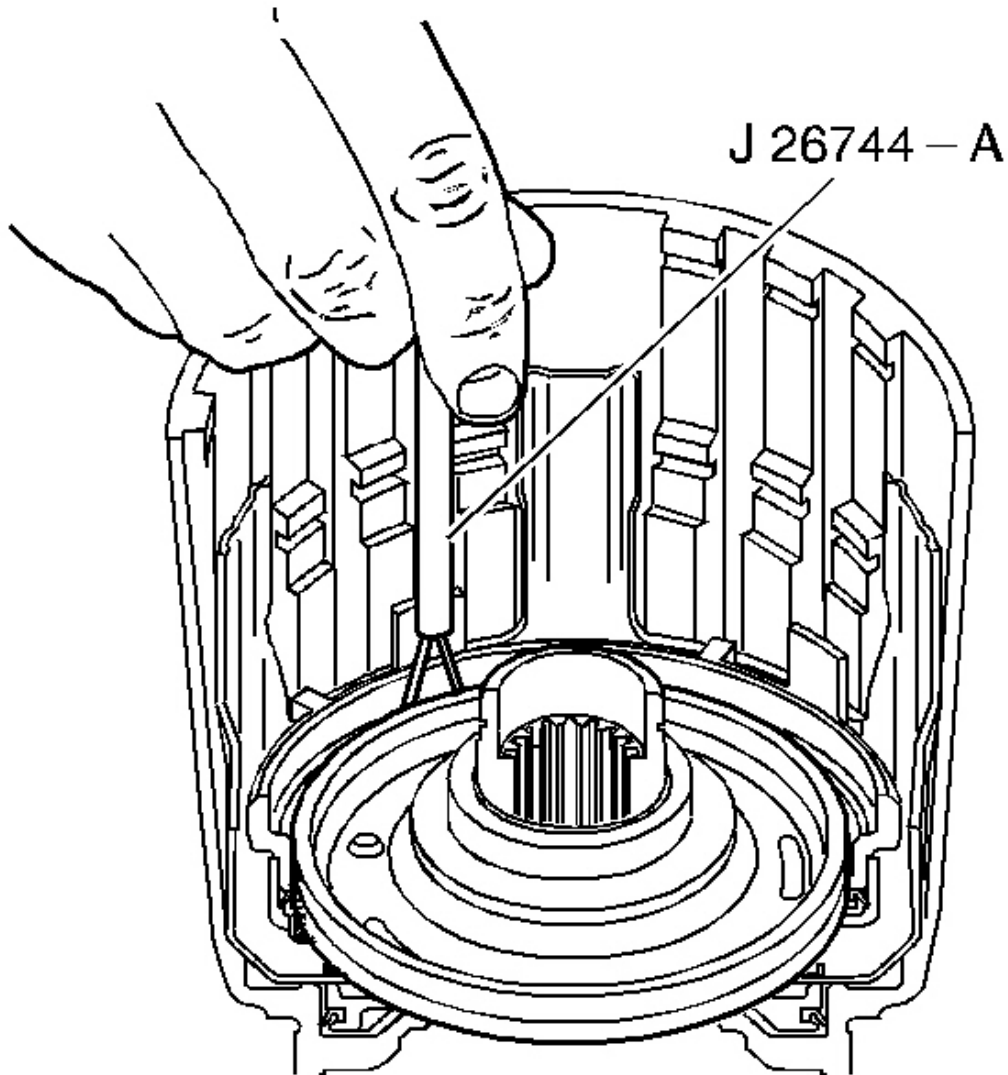

Fig. 325: Installing Overrun Clutch Piston Outer Seal With J 26744-A
Courtesy of GENERAL MOTORS CORP.

16. Using the **J 26744-A** , carefully install the overrun clutch piston outer seal. See **Special Tools**.

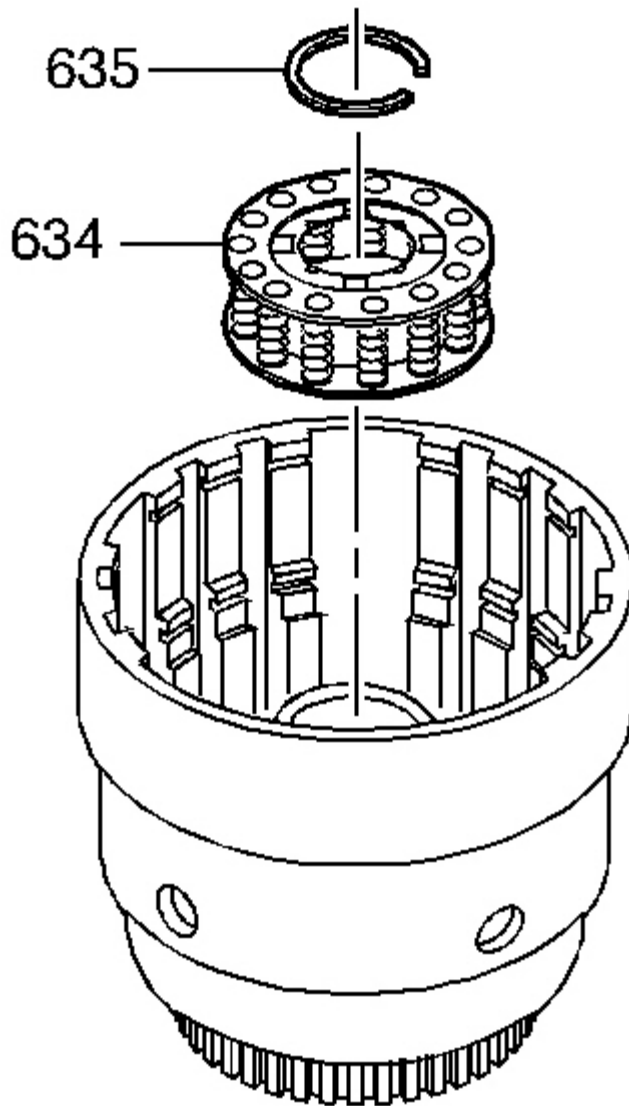

Fig. 326: View Of Overrun Clutch Spring Assembly
Courtesy of GENERAL MOTORS CORP.

17. Install the overrun clutch spring (634) assembly.

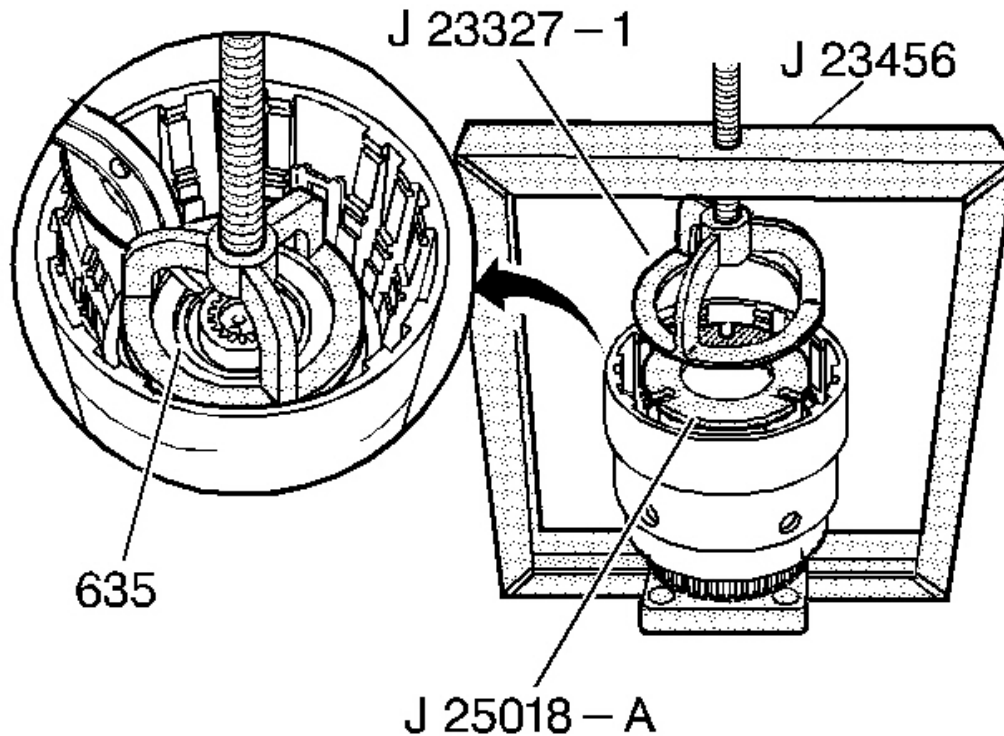

Fig. 327: Installing J 23327-1 & J 25018-A
 Courtesy of GENERAL MOTORS CORP.

18. Install the **J 23327-1** and the **J 25018-A** and compress the overrun clutch spring assembly using **J 23456** . See **Special Tools**.
19. Install the overrun clutch spring retainer snap ring (635).
20. Remove the **J 23327-1** and the **J 25018-A** . See **Special Tools**.

INPUT HOUSING TO OUTPUT SHAFT SEAL INSTALLATION

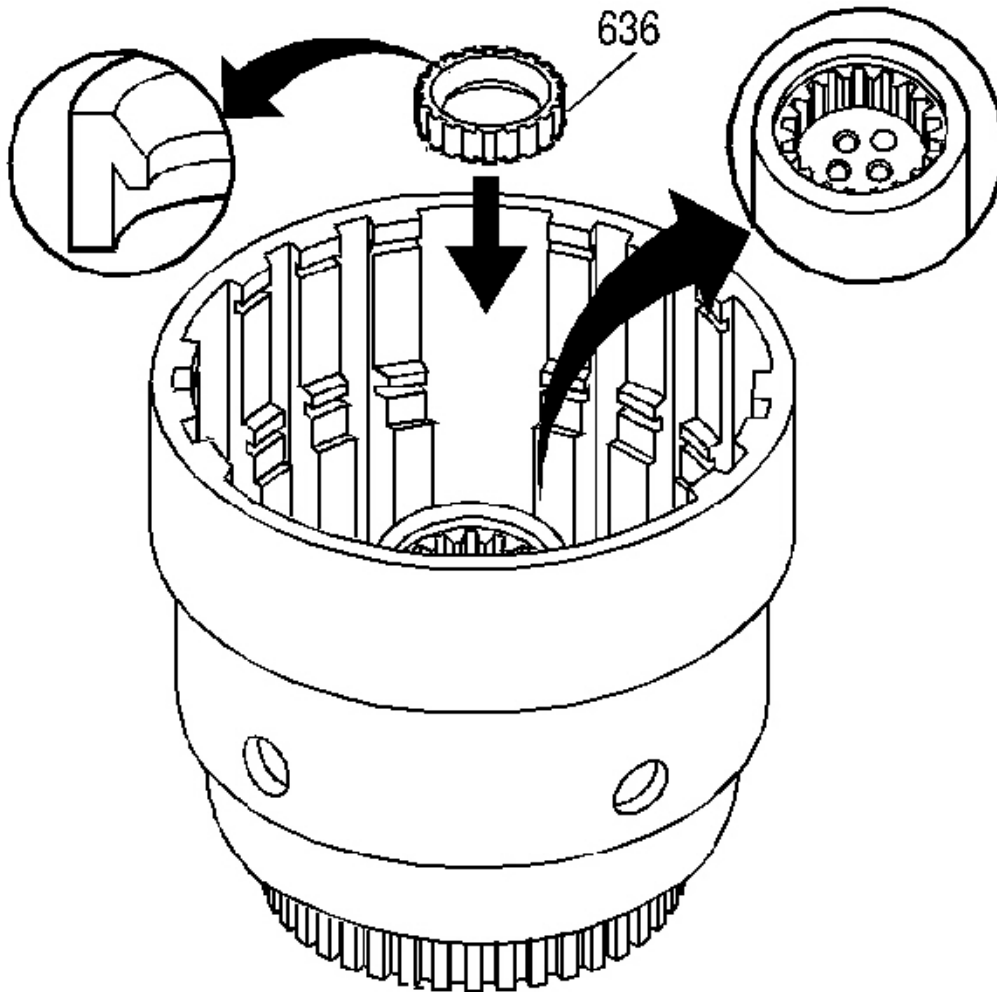

Fig. 328: View Of Input Housing To Output Shaft Seal
Courtesy of GENERAL MOTORS CORP.

Install a new input housing to output shaft seal (636).

OVERRUN CLUTCH INSTALLATION

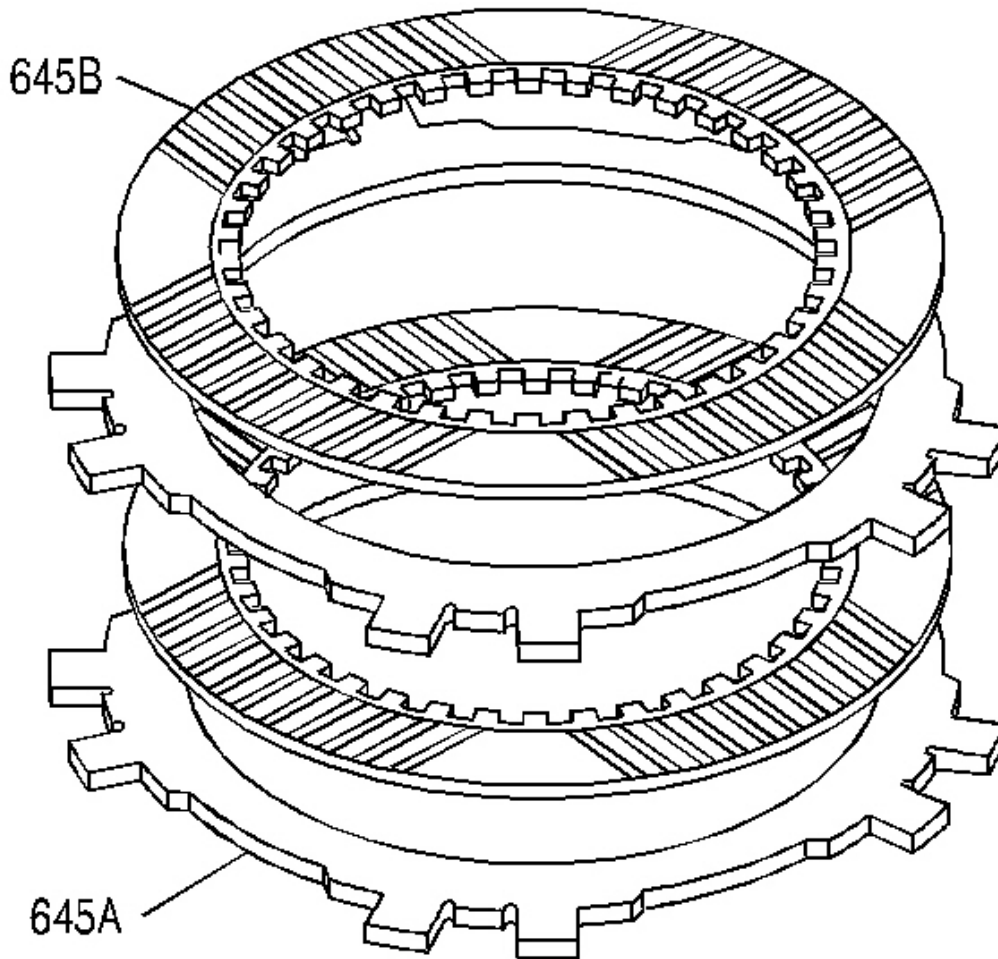

Fig. 329: Identifying Overrun Clutch Plates
Courtesy of GENERAL MOTORS CORP.

1. Inspect the fiber plate assemblies (645B) and the steel plates (645A) for the following defects:
 - Damaged tangs
 - Delamination
 - Excessive wear
 - Wear or heat damage

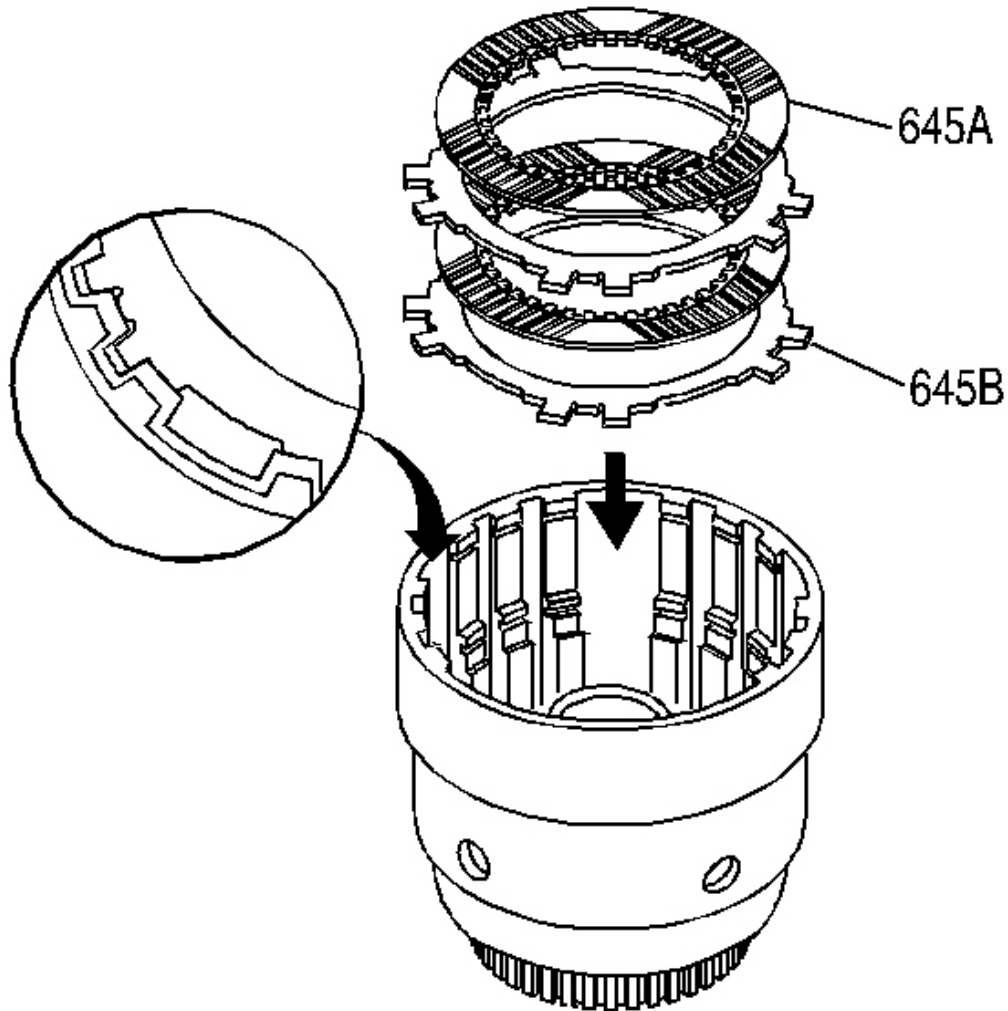

Fig. 330: Aligning Overrun Clutch Plates
Courtesy of GENERAL MOTORS CORP.

2. Install the overrun clutch plates into the input housing starting with a steel plate (645B) and alternating with fiber plate assemblies (645A).
3. Index the plates in the input housing with the wide notches remaining open.

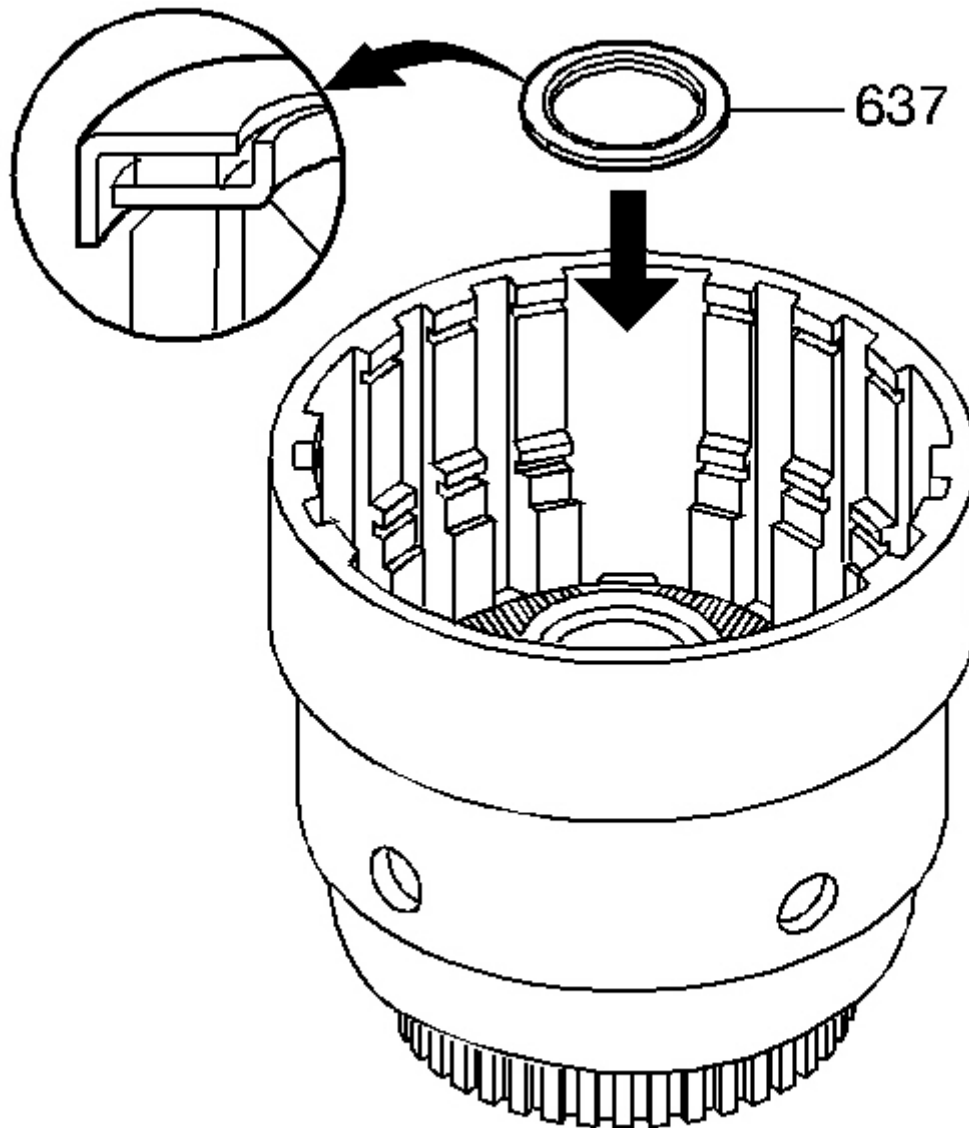

Fig. 331: Input Sun Gear Bearing Assembly
Courtesy of GENERAL MOTORS CORP.

4. Install the input sun gear bearing assembly (637) into the input housing.

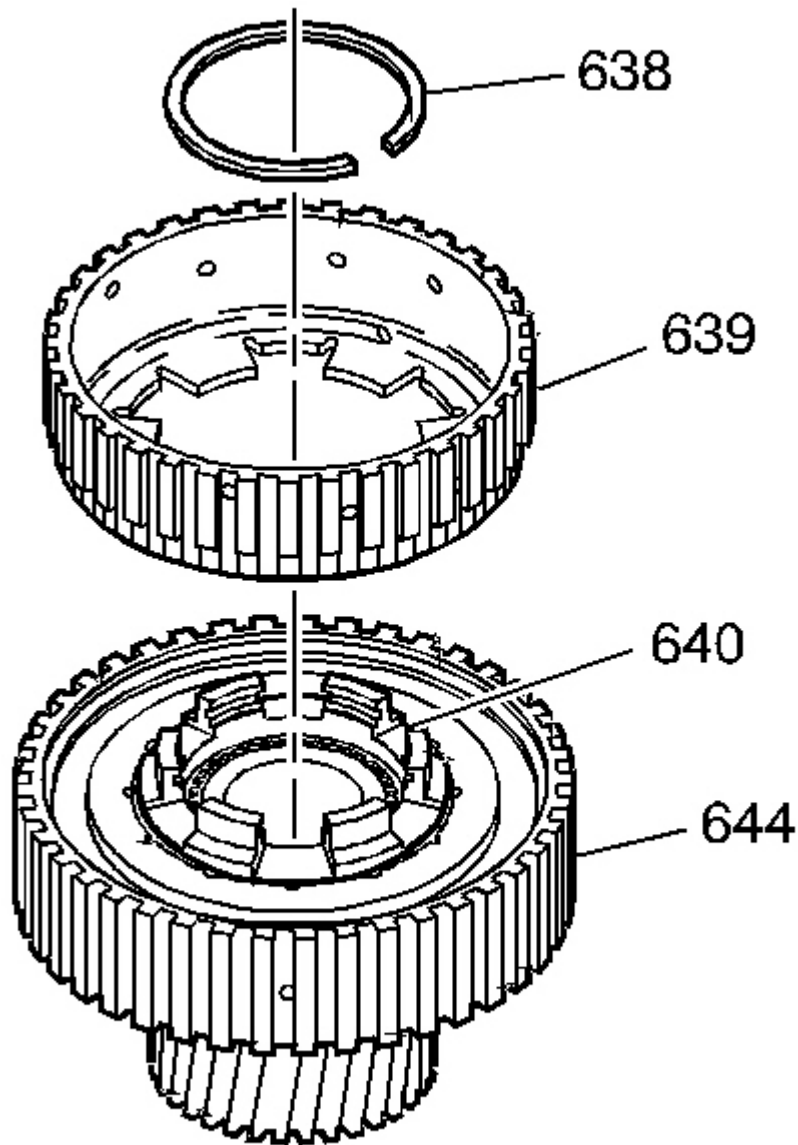

Fig. 332: Locating Overrun Clutch
Courtesy of GENERAL MOTORS CORP.

1. Remove the overrun clutch hub retaining snap ring (638).
2. Remove the overrun clutch hub (639).

3. Remove the forward sprag clutch inner race and input sun gear assembly (640).

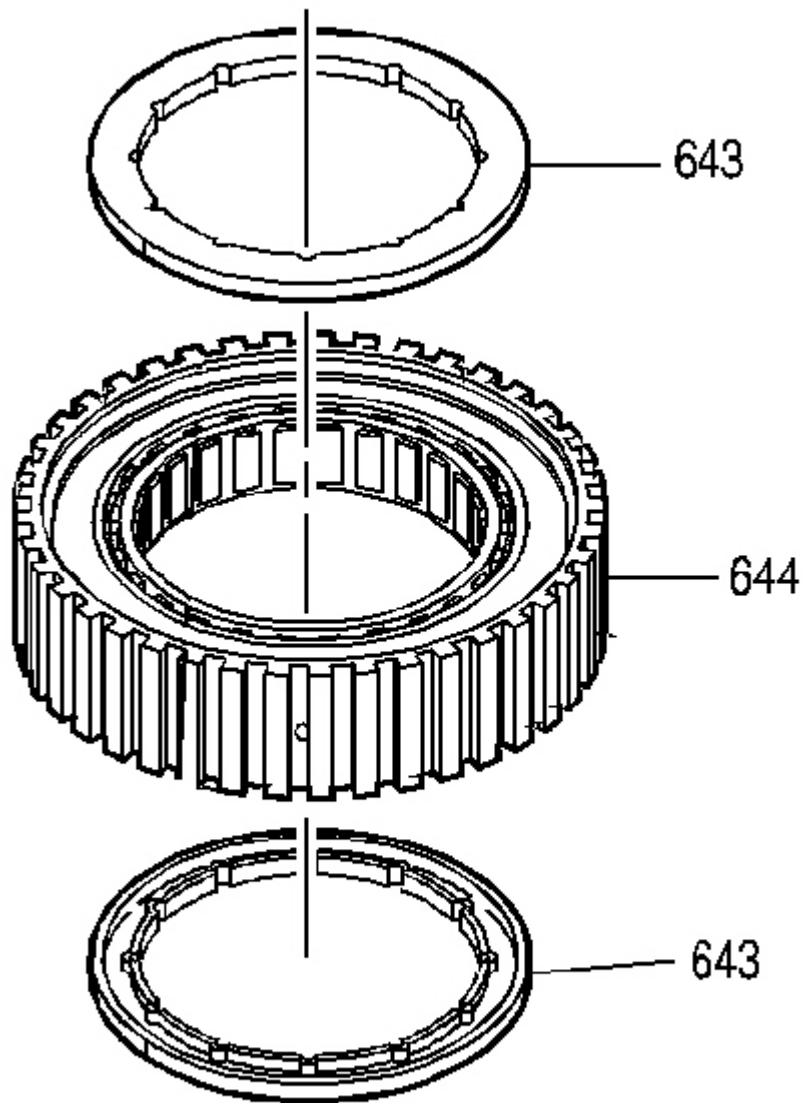

Fig. 333: View Of Sprag Assembly Retainer Rings
Courtesy of GENERAL MOTORS CORP.

4. Remove the sprag assembly retainer rings (643).
5. Remove the forward sprag assembly from the forward clutch outer race (644).

FORWARD CLUTCH SPRAG ASSEMBLY

Fig. 334: Forward Sprag Assembly
Courtesy of GENERAL MOTORS CORP.

1. Inspect the forward sprag assembly (642) for the following conditions:
 - Wear or damage
 - Weak or broken springs
2. Inspect the forward clutch outer race (644) for the following conditions:

- Race wear or damage
- Spline wear
- Surface finish damage

3. Install the forward sprag assembly (642) into the forward clutch outer race (644).

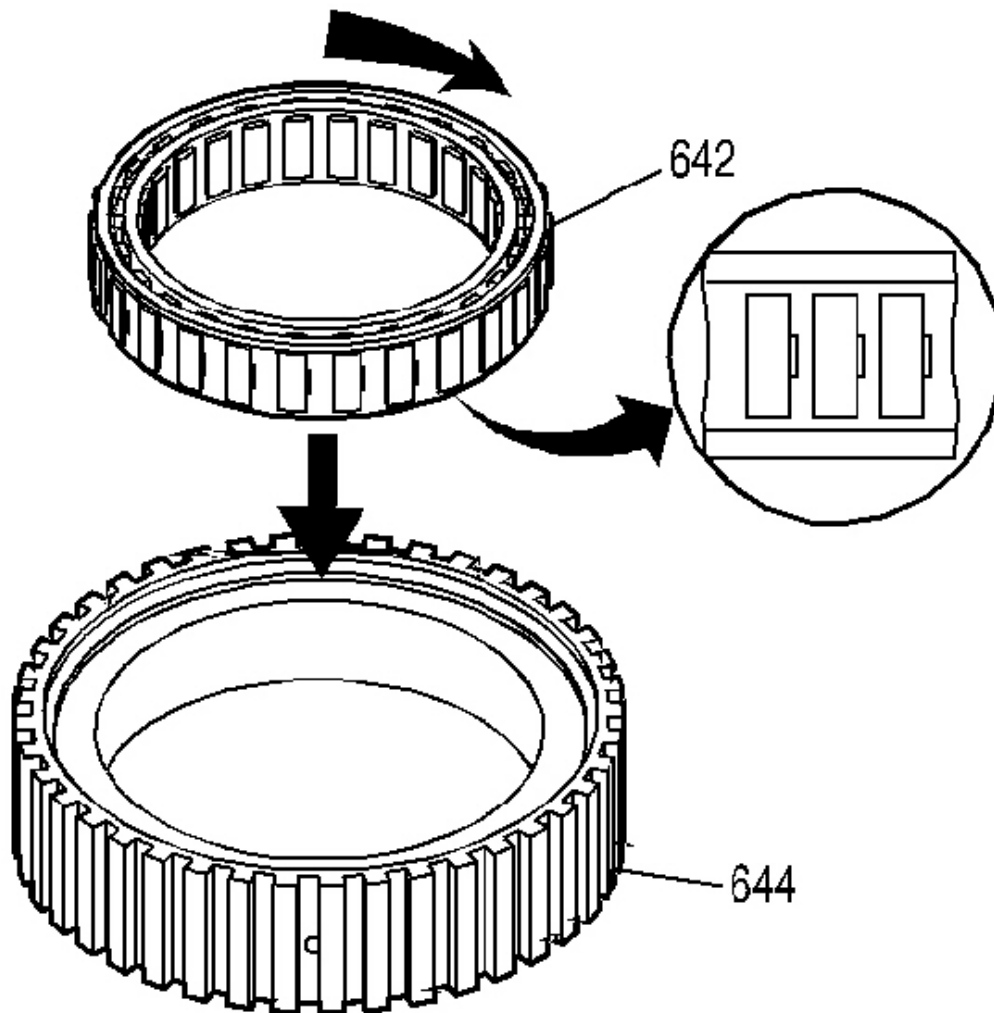
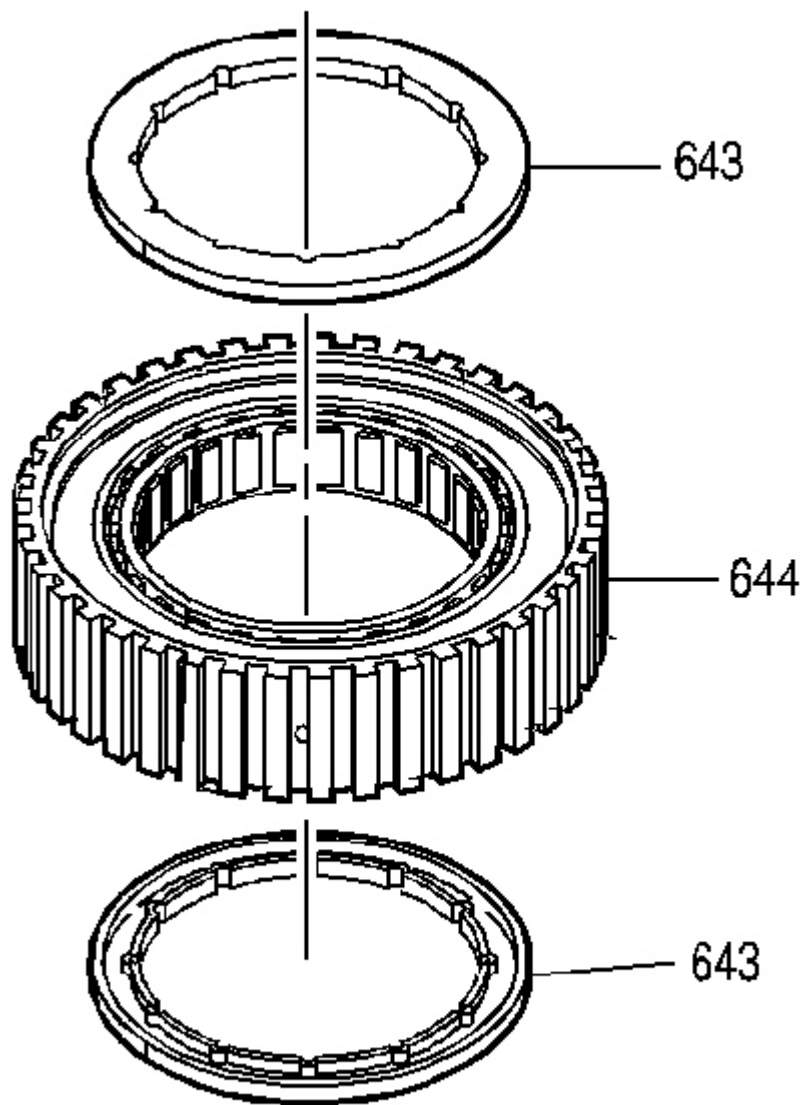

Fig. 335: View Of Sprag Assembly Retainer Rings

Courtesy of GENERAL MOTORS CORP.

4. Inspect the sprag assembly retainer rings (643) for wear or damage.
5. Install the sprag assembly retainer rings (643) into the forward clutch sprag assembly (644).

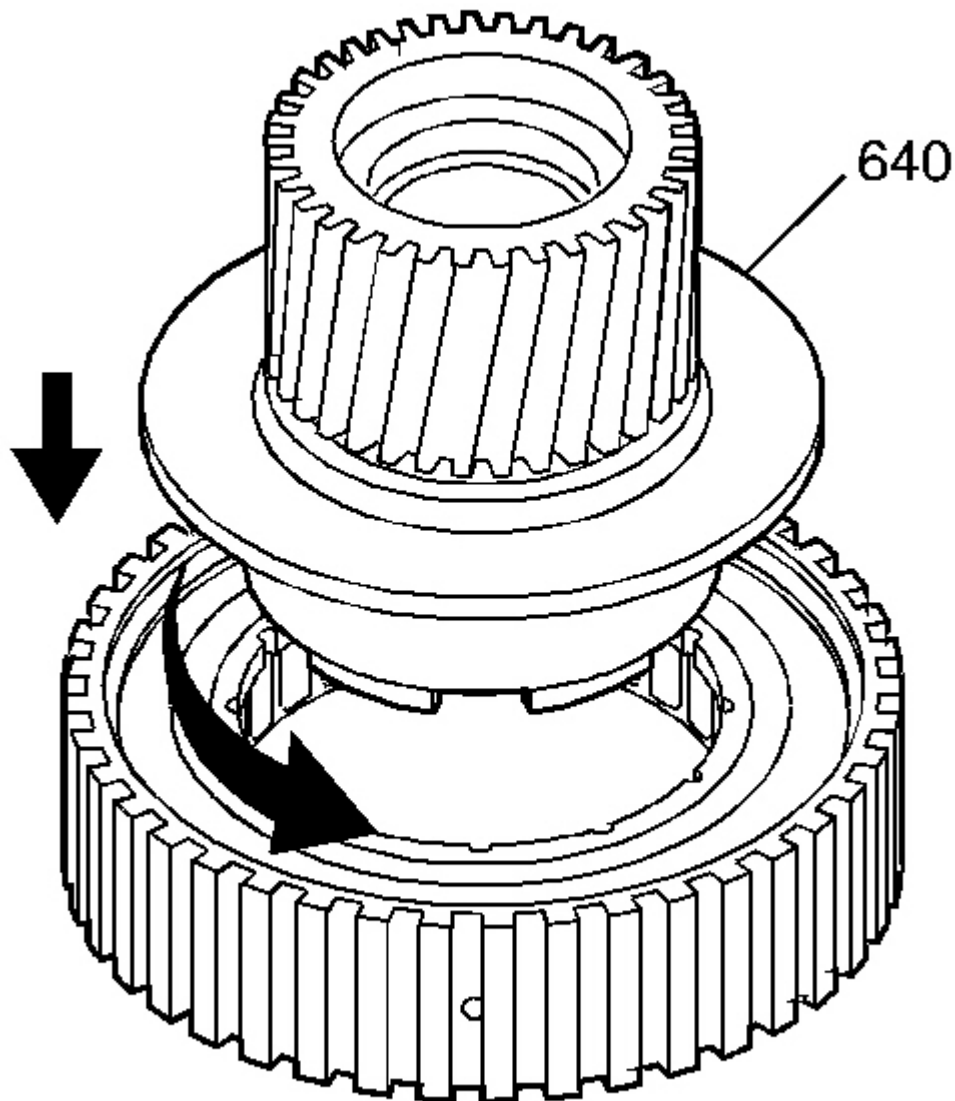

Fig. 336: Inspection Areas On Forward Sprag Clutch Inner Race And Input Sun Gear Assembly

Courtesy of GENERAL MOTORS CORP.

6. Inspect the forward sprag clutch inner race and input sun gear assembly (640) for the following conditions:
 - Damaged spline or gear teeth
 - Ring groove damage
 - Surface finish damage
 - Loose retainer
 - Wear
 - Cracks
7. Install the forward sprag clutch inner race and input sun gear assembly (640) into the forward sprag and outer race assembly.

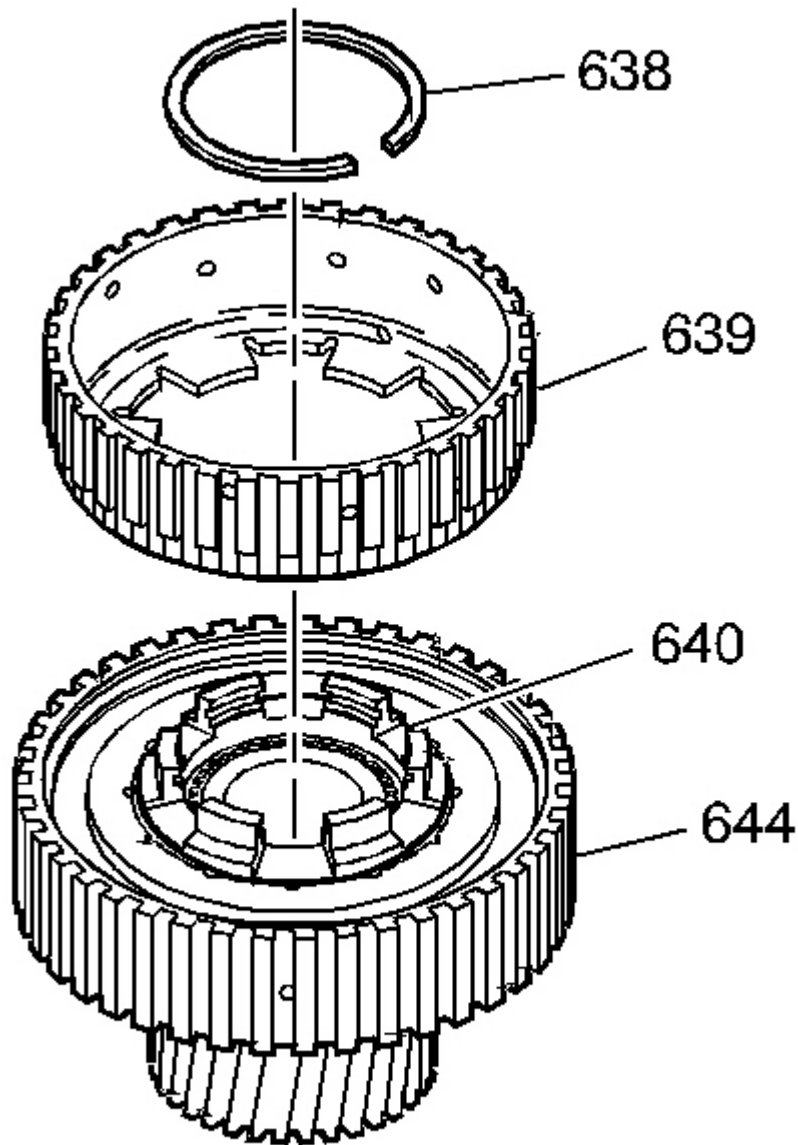

Fig. 337: Locating Overrun Clutch
Courtesy of GENERAL MOTORS CORP.

8. Inspect the overrun clutch hub (639) for the following conditions:
 - Spline damage

2007 Hummer H3

2007 TRANSMISSION Automatic Transmission - 4L60-E/4L65-E/4L70-E - H3

- Plugged lubrication holes
 - Damaged tangs
 - Cracks
9. Install the overrun clutch hub (639) onto the sprag clutch inner race and input sun gear assembly (640).
 10. Install the overrun clutch hub retaining snap ring (638).

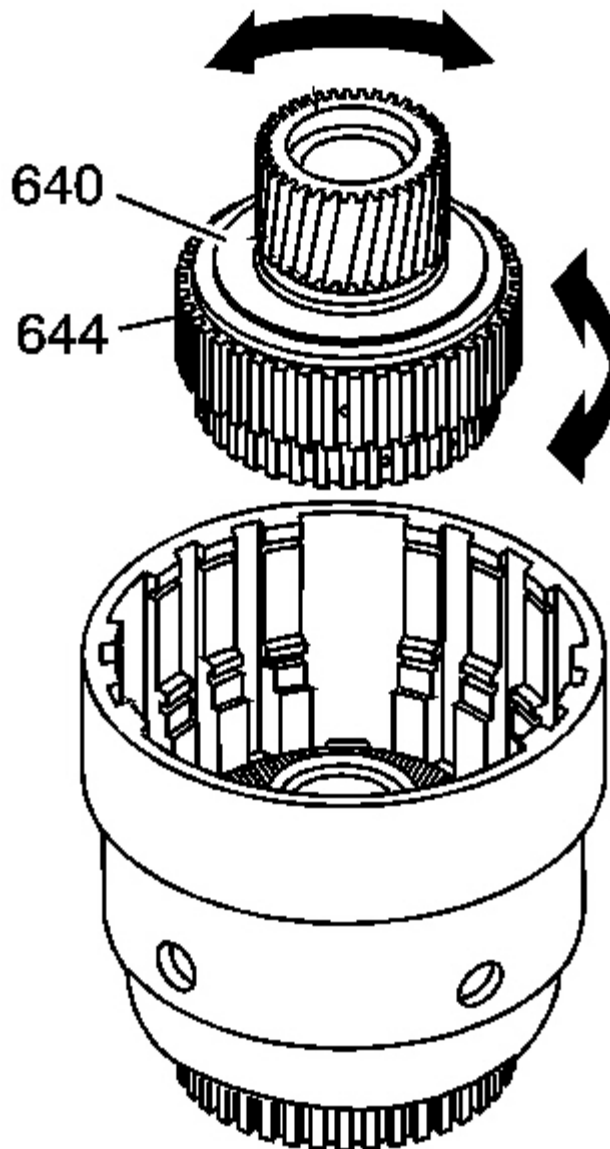

Fig. 338: Checking Sun Gear Rotation
Courtesy of GENERAL MOTORS CORP.

IMPORTANT: If the forward clutch sprag assembly operates backward, you have installed the sprag backward. Reassemble the sprag

correctly.

11. Test the forward clutch sprag assembly for proper operation.
 1. Position the forward clutch sprag assembly with the input sun gear facing up.

IMPORTANT: The sun gear should only rotate in a counterclockwise direction.

2. Hold the forward sprag clutch outer race (644) with one hand and rotate the input sun gear (640) with the other hand.
12. Install the forward clutch sprag and input sun gear assembly into the input clutch housing.
13. Index the overrun clutch hub into the overrun clutch plates.

FORWARD CLUTCH ASSEMBLY ASSEMBLE

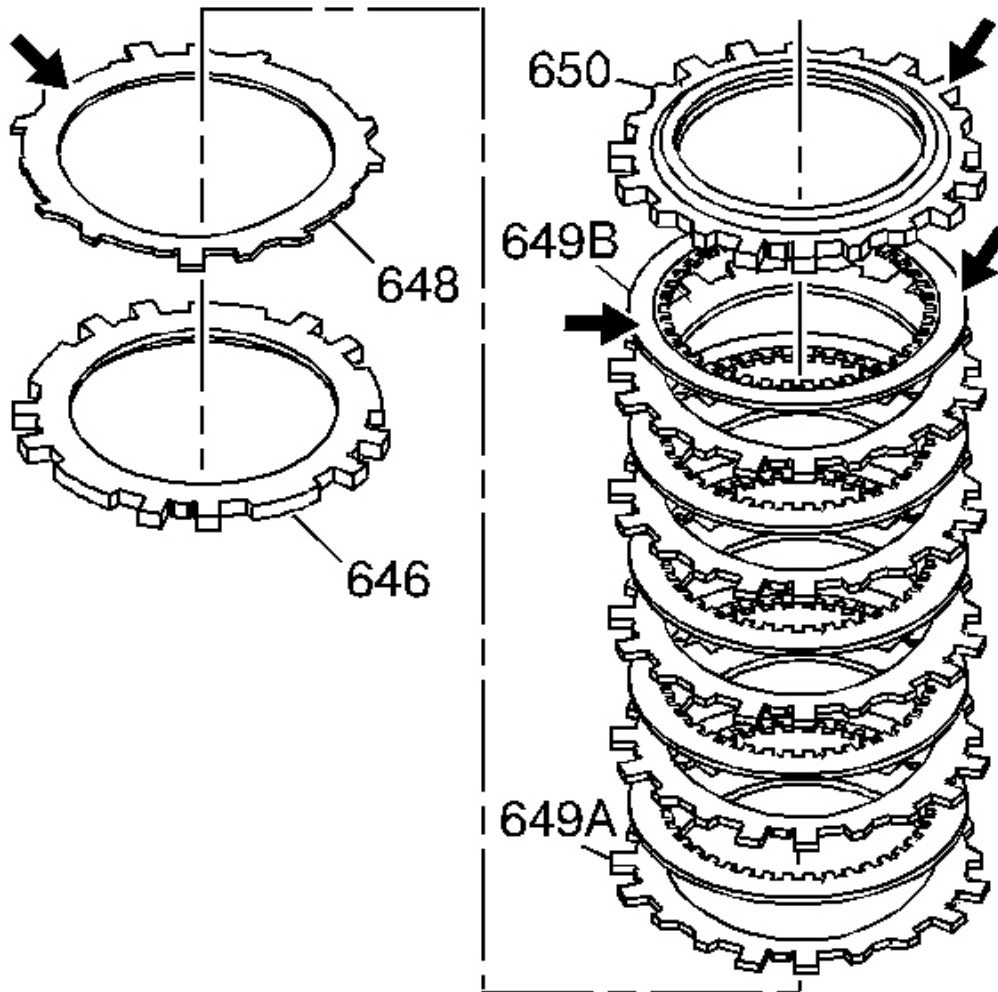

Fig. 339: Inspecting Forward Clutch Assembly For Wear Or Damage
Courtesy of GENERAL MOTORS CORP.

1. Inspect the forward clutch waved plate (648), the apply plate (646), the fiber plate assemblies (649B), the steel plates (649A) and the selective backing plate (650) for the following conditions:
 - Damaged tangs
 - Delamination
 - Excessive wear

- Heat damage
- Flatness
- Surface finish damage
- Burrs and nicks

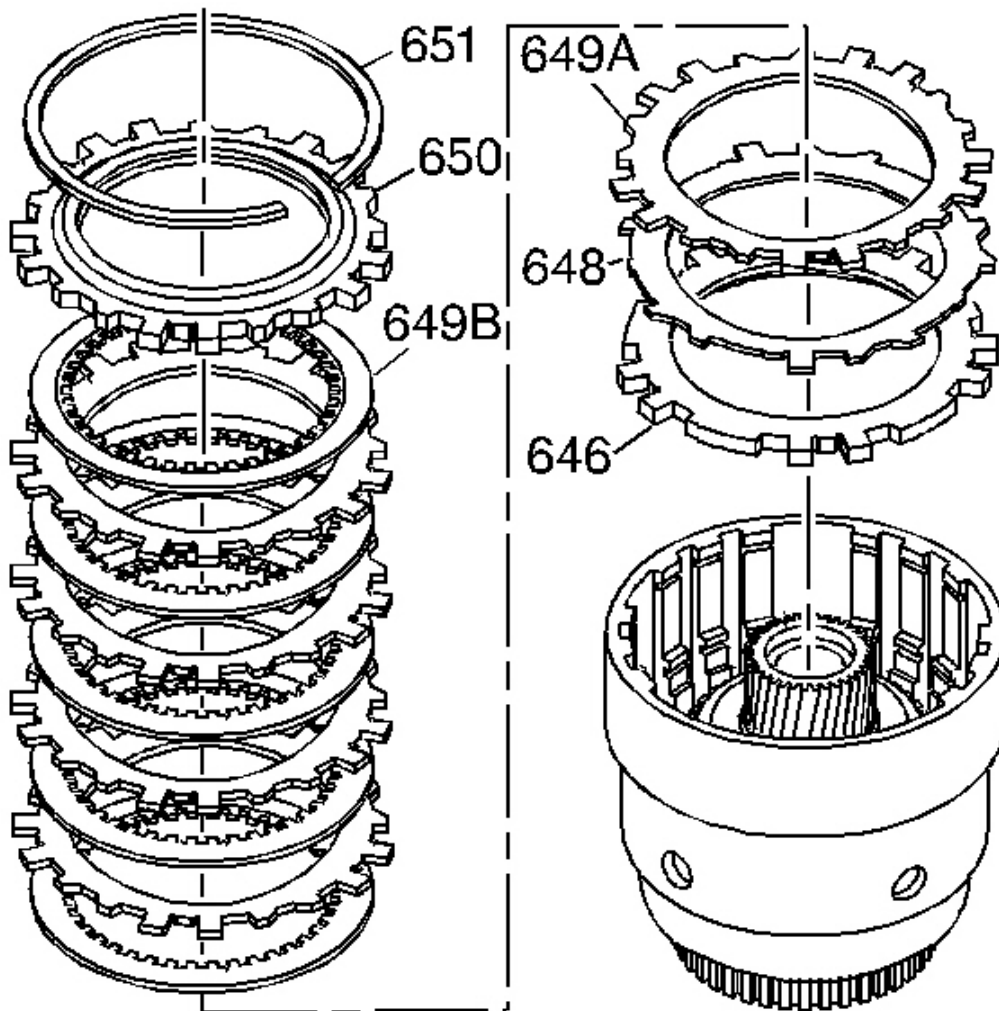

Fig. 340: Identifying Forward Clutch Apply Plates
Courtesy of GENERAL MOTORS CORP.

2. Install the forward clutch apply plate (646).

3. Install the forward clutch waved plate (648).
4. Install the forward clutch steel plates (649A) and alternate with the fiber plate assemblies (649B).
5. Install the forward clutch selective backing plate (650).
6. Install the forward clutch backing plate retainer ring (651).

FORWARD CLUTCH PISTON TRAVEL CHECK

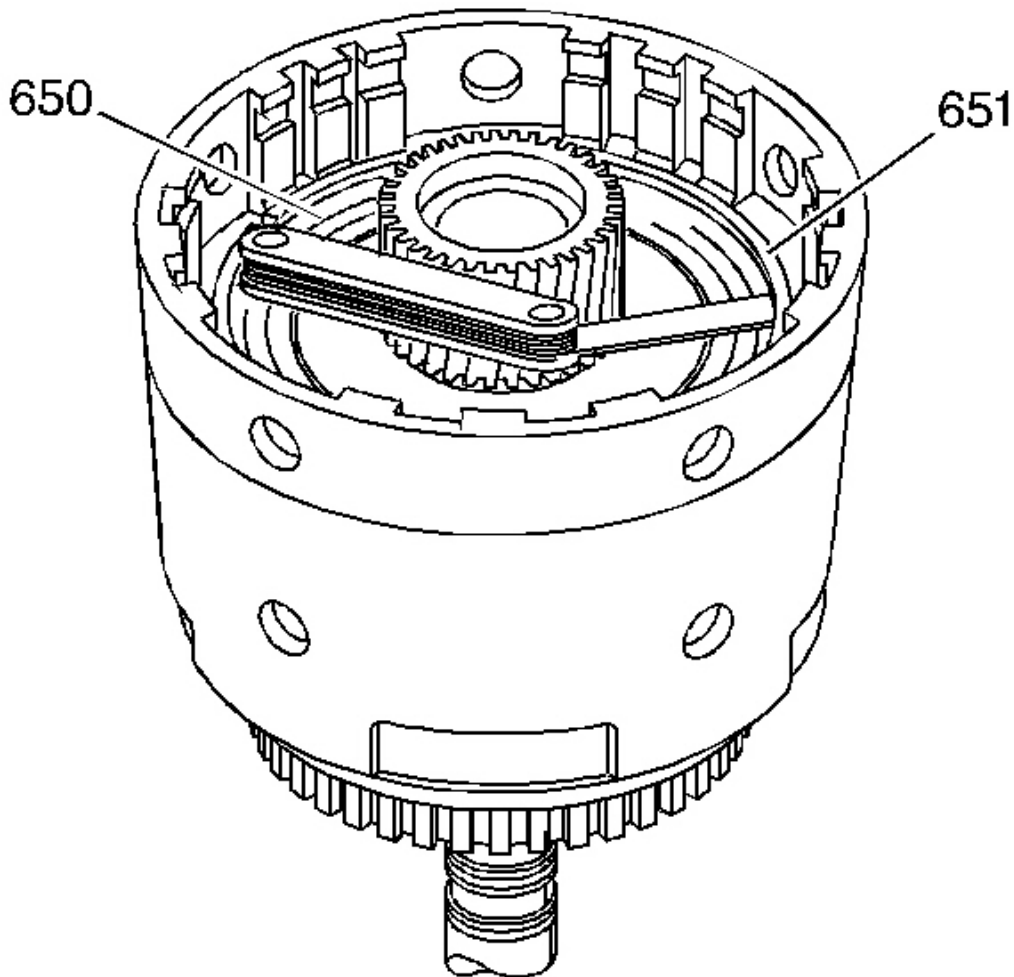

Fig. 341: Measuring Forward Clutch Plate Travel
Courtesy of GENERAL MOTORS CORP.

2007 Hummer H3

2007 TRANSMISSION Automatic Transmission - 4L60-E/4L65-E/4L70-E - H3

1. Use feeler gauges to check the forward clutch plate travel. Check travel between the forward clutch backing plate retainer ring (651) and the forward clutch selective backing plate (650).

The forward clutch plate travel should be:

Specification: 0.876-1.866 mm (0.034-0.073 in)

2. Select the proper forward clutch selective backing plate (650) to obtain the correct travel. Refer to **Forward Clutch Backing Plate Selection** .

3-4 CLUTCH ASSEMBLE

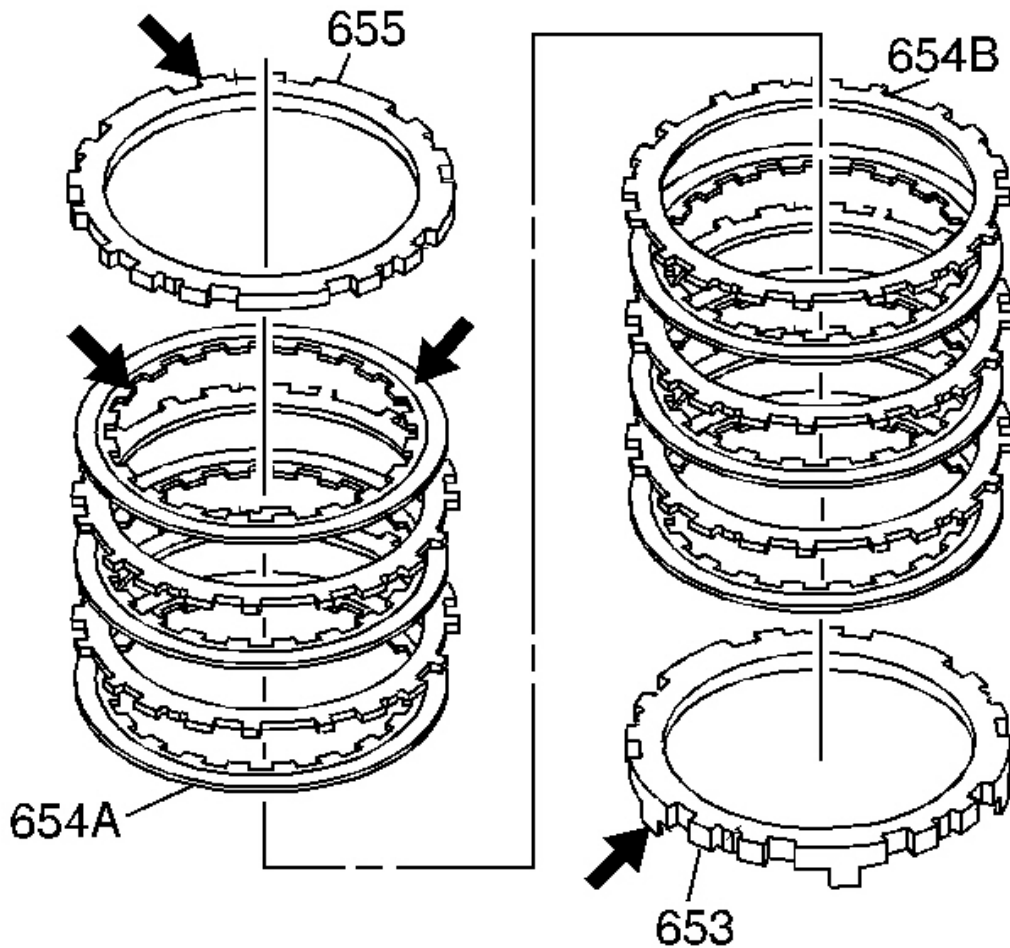

Fig. 342: View Of Inspection Areas On Clutch Apply Plates
Courtesy of GENERAL MOTORS CORP.

IMPORTANT: The part 654A may have 5, 6 or 7 plates.

1. Inspect the 3rd and 4th clutch apply plate (653), the fiber plate assemblies (654A), the steel plates (654B) and the selective backing plate (655) for the following conditions:
 - Damaged tangs
 - Delamination
 - Excessive wear
 - Heat damage or wear

- Surface finish
- Flatness

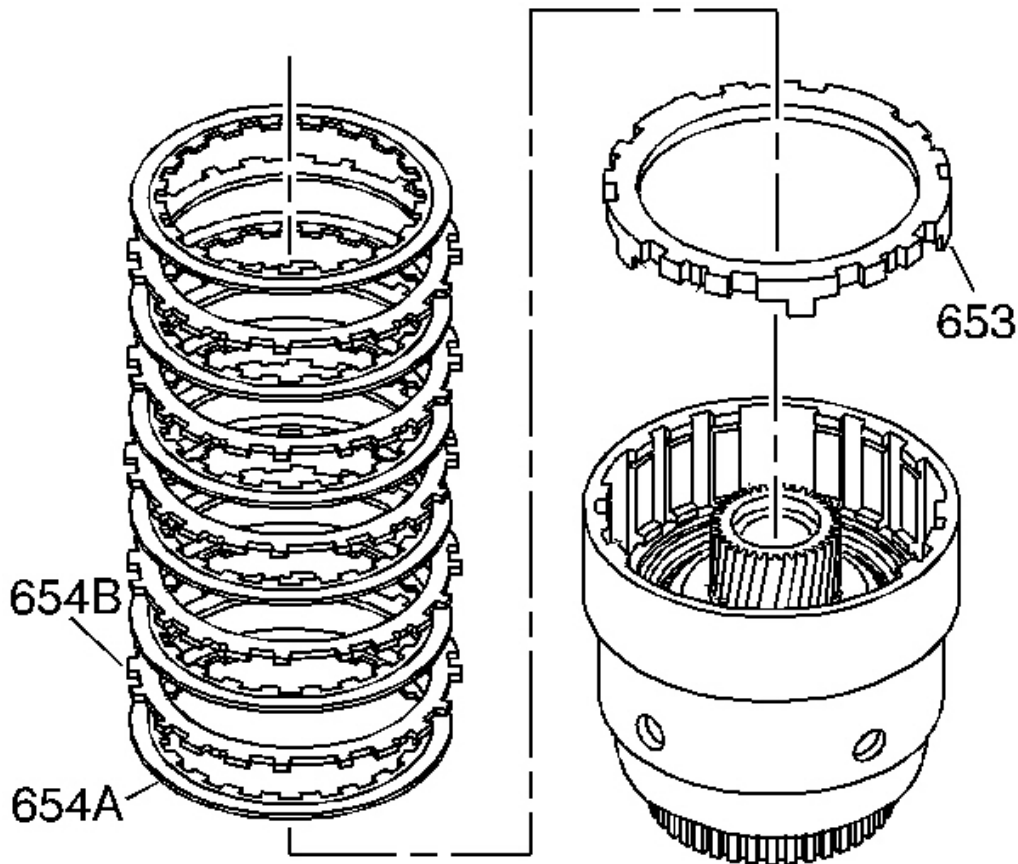

Fig. 343: Installing Clutch Apply Plates Into Input Housing
Courtesy of GENERAL MOTORS CORP.

2. Install the 3rd and 4th clutch apply plate (653) into the input housing. Index each leg of the apply plate into the apply ring legs.

NOTE: The correct number of fiber plates must be used to avoid damage to the transmission. An incorrect stack up height can cause either excessive clutch slippage or insufficient release, resulting in burned clutch plates.

IMPORTANT: The first steel plate (654B) has the same spline configuration as the 3rd and 4th clutch apply plate (653).

IMPORTANT: The 3rd and 4th clutch plate stack is model specific. Clutch plate stack up could be either 6 or 7 plates.

3. Install the 3rd and 4th clutch plates starting with a fiber plate assembly (654A) and alternate with a steel plate (654B).

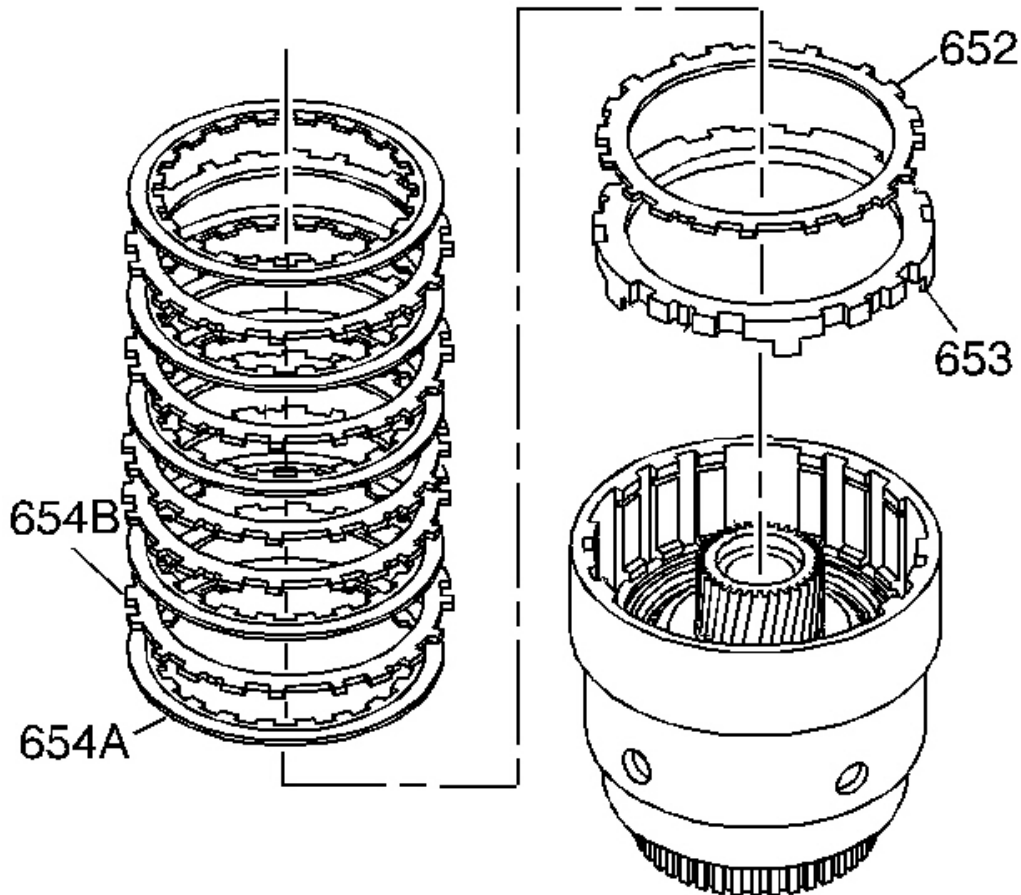

Fig. 344: Illustrating Clutch Plate Assembly
Courtesy of GENERAL MOTORS CORP.

4. Continue the stack up if seven 654A plates are used.

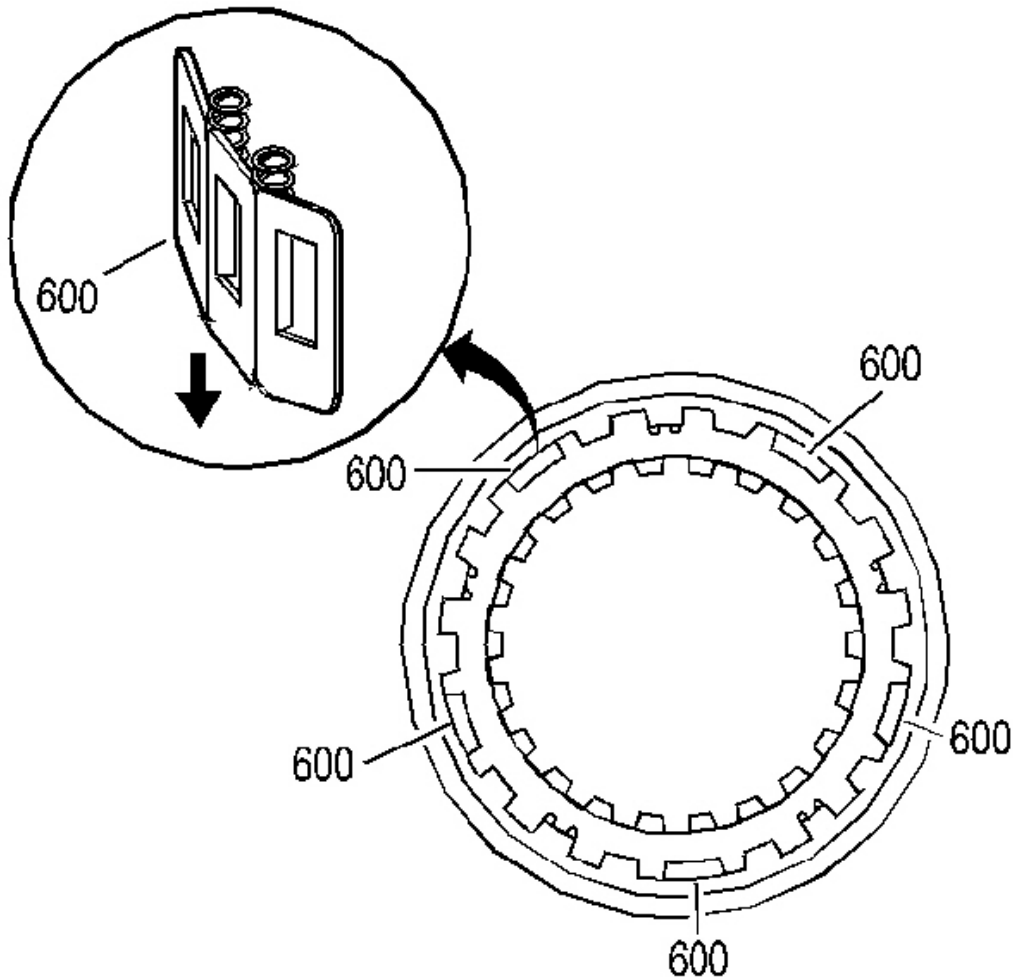

Fig. 345: Identifying 3-4 Clutch Boost Spring Assemblies
Courtesy of GENERAL MOTORS CORP.

5. Inspect the five 3-4 clutch boost spring assemblies (600) for damaged, worn, broken or missing springs. Springs must be held securely by retainer.
6. Install the 3-4 clutch boost spring assemblies (600) into the input housing.

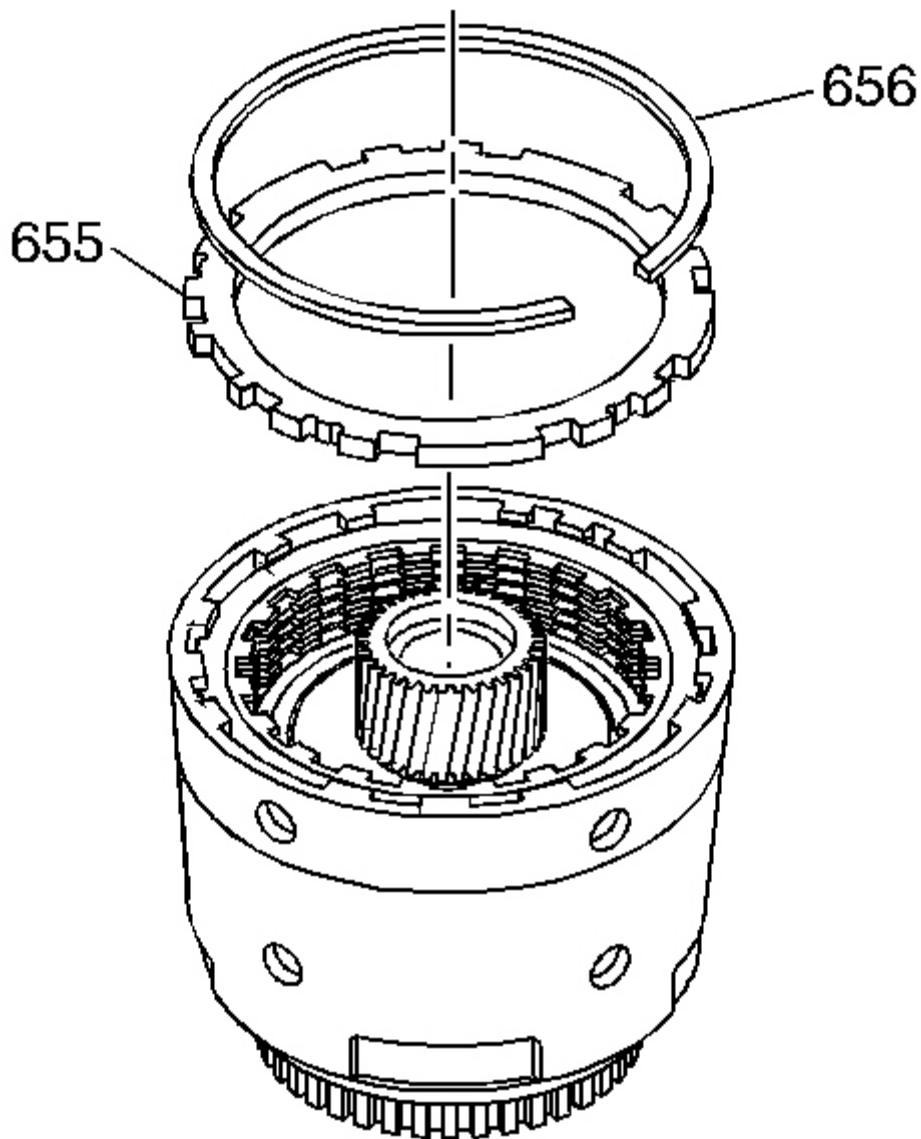

Fig. 346: Locating 3rd & 4th Clutch Selective Backing Plate & Retainer Ring
Courtesy of GENERAL MOTORS CORP.

7. Install the 3rd and 4th clutch selective backing plate (655). Some models may have a chamfer on one side of the selective backing plate. Install the chamfer side up.
8. Install the 3rd and 4th clutch backing plate retainer ring (656).

3-4 CLUTCH PLATE TRAVEL CHECK

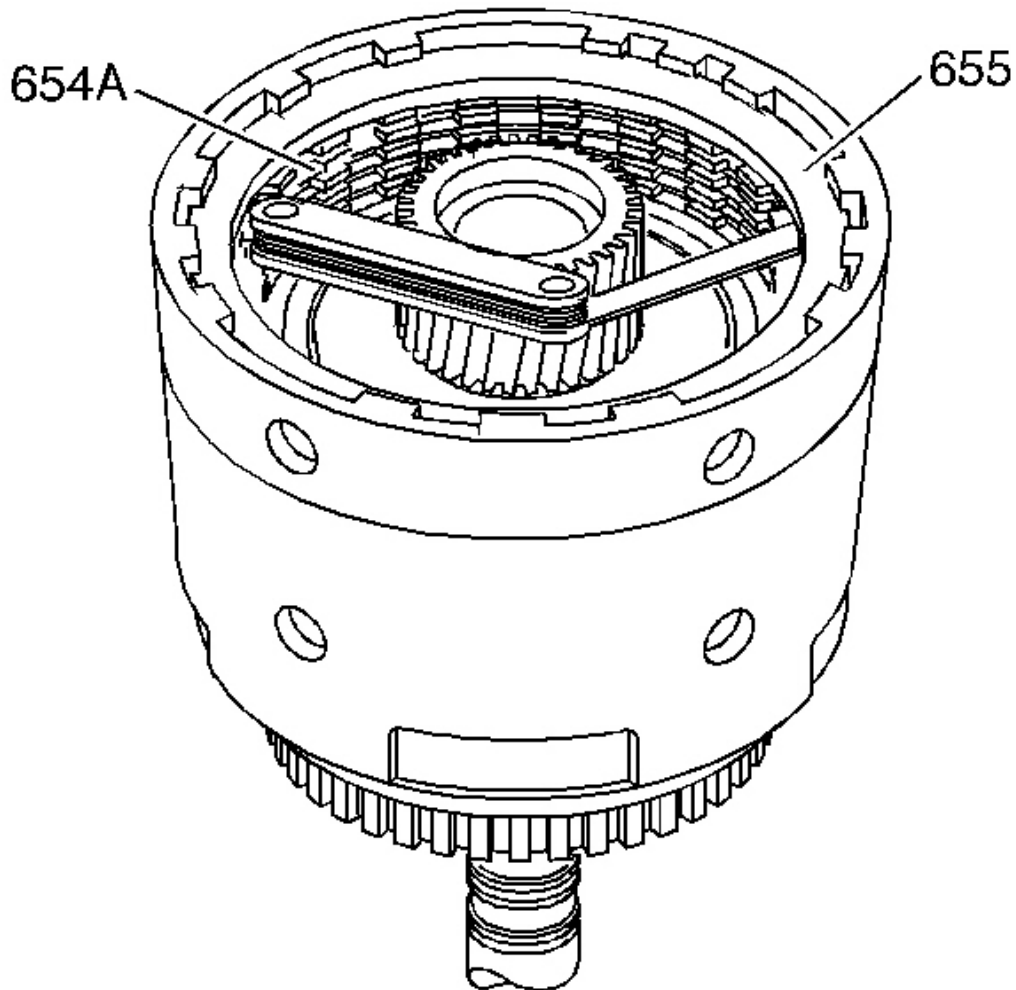

Fig. 347: Checking 3rd & 4th Clutch Plate Travel
Courtesy of GENERAL MOTORS CORP.

1. Use feeler gauges to check the 3rd and 4th clutch plate travel.
2. Check the travel between the selective backing plate (655) and the first fiber plate assembly (654A).

The 3rd and 4th clutch plate travel should be:

2007 Hummer H3

2007 TRANSMISSION Automatic Transmission - 4L60-E/4L65-E/4L70-E - H3

Specification:

- Five plate - 0.99-2.14 mm (0.038-0.084 in)
 - Six plate - 0.90-2.10 mm (0.035-0.082 in)
 - Seven plate - 1.12-2.04 mm (0.044-0.080 in)
3. Select the proper 3rd and 4th clutch selective backing plate to obtain the correct travel.
Refer to **Third and Fourth Clutch Backing Plate Selection** .

CLUTCH AIR CHECK

Inspection Procedure

IMPORTANT: When the overrun clutch is checked, the air will blow by the forward clutch piston lip seals and exit out of the forward clutch feed hole in the turbine shaft.

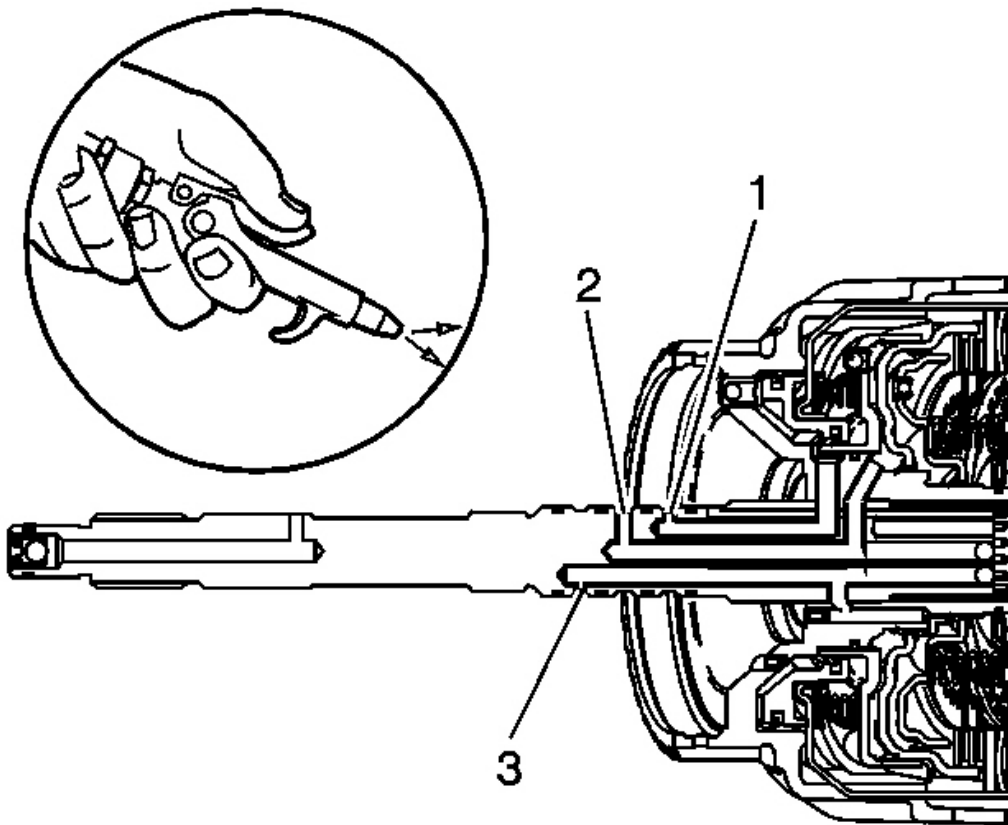

Fig. 348: Applying Air Into Feed Holes
 Courtesy of GENERAL MOTORS CORP.

Apply air into the feed holes in the turbine shaft in order to check the following items:

- The 3rd and 4th clutch (1)
- The forward clutch (2)
- The overrun clutch (3)

TURBINE SHAFT SEAL INSTALLATION

Tools Required

- **J 36418-1B** Turbine Shaft Seal Installer. See **Special Tools**.
- **J 36418-2A** Turbine Shaft Seal Sizer. See **Special Tools**.

Installation Procedure

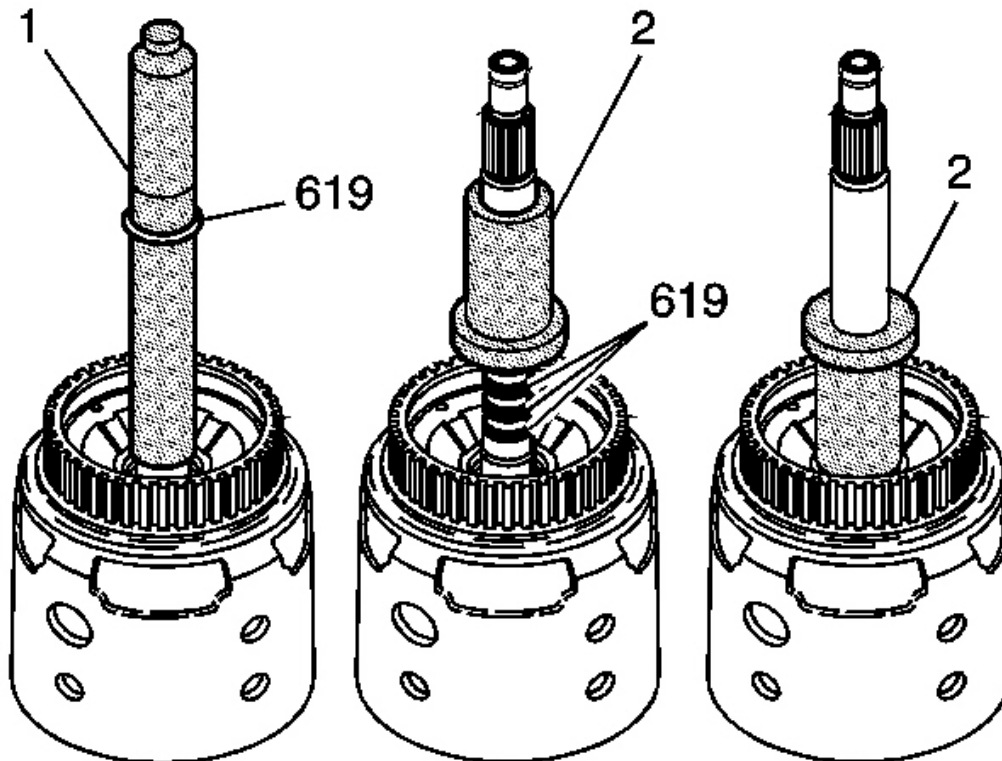

Fig. 349: Installing Turbine Shaft Oil Seal Rings
 Courtesy of GENERAL MOTORS CORP.

1. Use the **J 36418-1B** (1) in order to install the four turbine shaft oil seal rings (619). See **Special Tools**.
2. Resize oil seal rings (619) after installation:
 1. Place **J 36418-2A** (2) over the turbine shaft oil seal rings (619) and seat against input housing. See **Special Tools**.
 2. Remove **J 36418-2A** (2). See **Special Tools**.
 3. Turn **J 36418-2A** (2) upside down and place over the turbine shaft oil seal ring (619). See **Special Tools**.
 4. Seat against input housing.
 5. Leave **J 36418-2A** (2) in place over the turbine shaft oil seal rings (619) until the

reverse input clutch housing is installed. See **Special Tools**.

REVERSE INPUT CLUTCH DISASSEMBLE

Tools Required

- **J 23327-1** Forward Clutch Spring Compressor (Bridge). See **Special Tools**.
- **J 25018-A** Clutch Spring Compressor Adapter. See **Special Tools**.

Disassembly Procedure

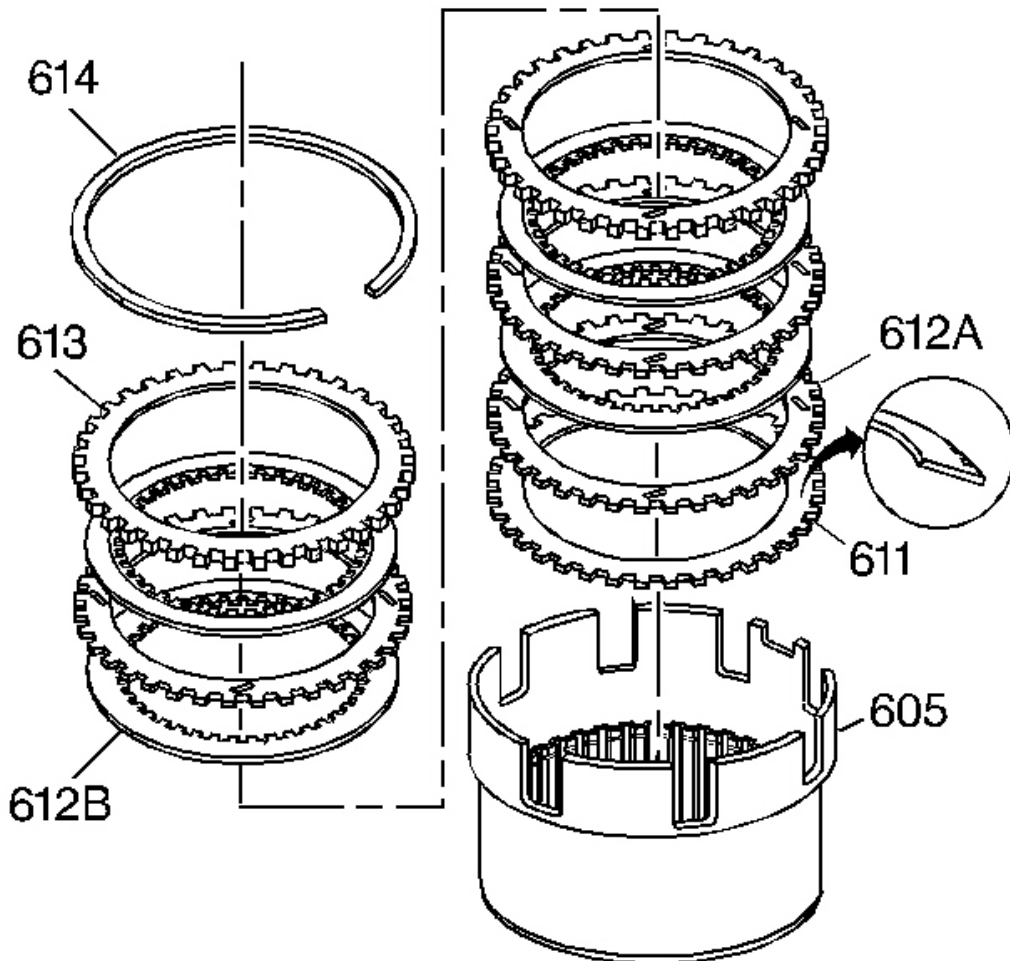

Fig. 350: Locating Reverse Input Clutch Plates

Courtesy of GENERAL MOTORS CORP.

1. Remove the reverse input clutch retaining ring (614).
2. Remove all reverse input clutch plates (611-613).

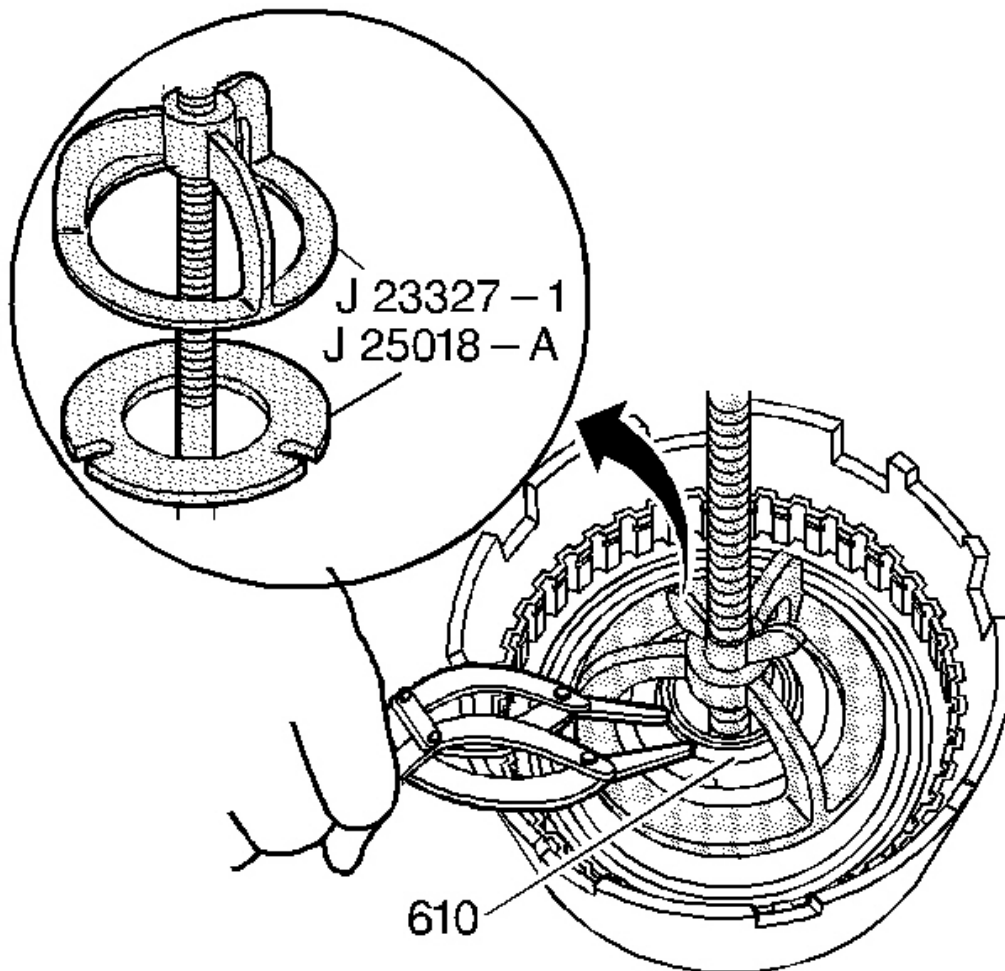

Fig. 351: View Of Reverse Input Clutch Spring Retainer Ring
Courtesy of GENERAL MOTORS CORP.

3. Install the **J 23327-1** and the **J 25018-A** . See **Special Tools**.
4. Compress the reverse input clutch spring assembly.
5. Remove the reverse input clutch spring retainer ring (610).

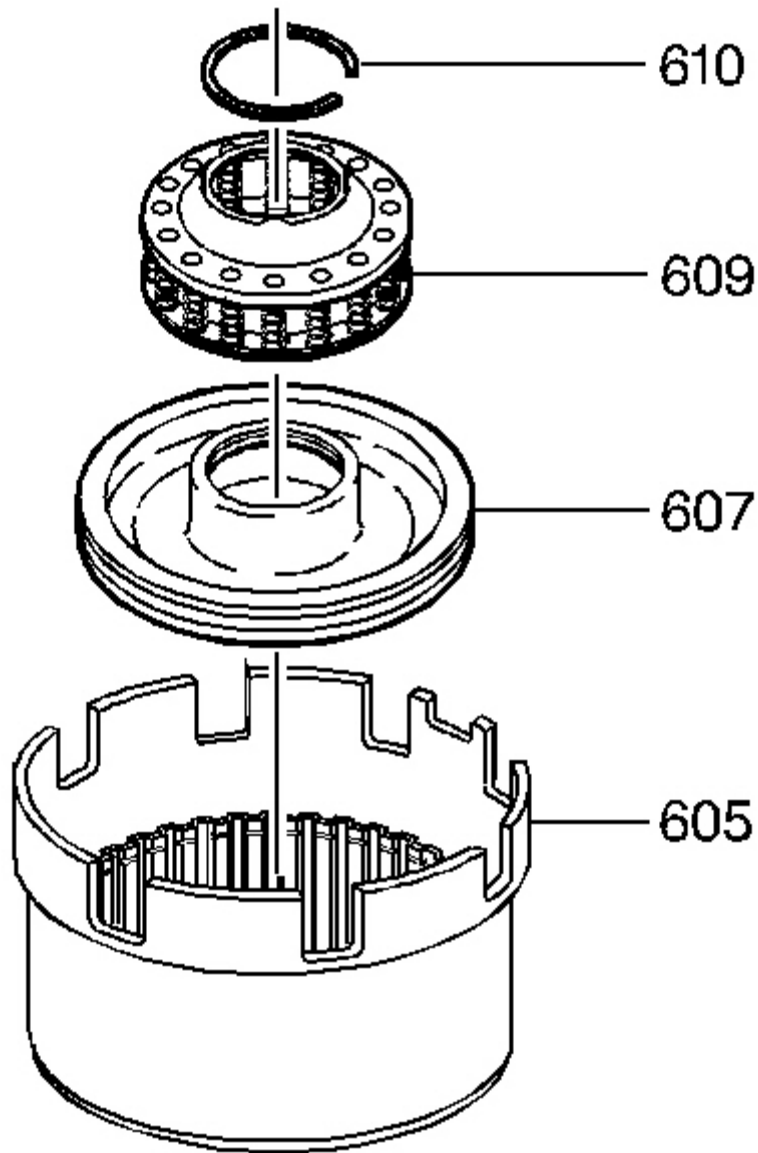

Fig. 352: Identifying Reverse Input Clutch Spring & Piston Assemblies
Courtesy of GENERAL MOTORS CORP.

6. Remove the reverse input clutch spring assembly (609).
7. Remove the reverse input clutch piston assembly (607).

REVERSE INPUT CLUTCH BUSHING REPLACEMENT

Tools Required

- **J 25019** Bushing Service Set. See Special Tools.
- **J 34196-B** Transmission Bushing Service Set. See Special Tools.
- **J 7004-A** Universal Remover. See Special Tools.
- **J 8092** Driver Handle

Removal Procedure

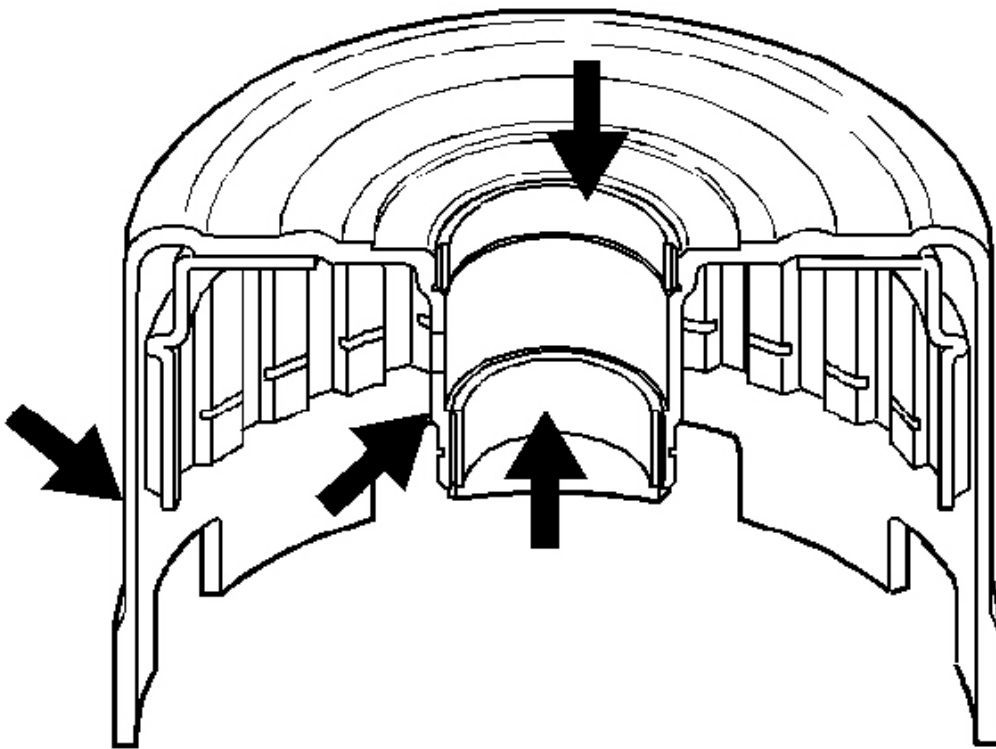

Fig. 353: Inspection Areas On Reverse Input Clutch Housing & Drum Assembly
Courtesy of GENERAL MOTORS CORP.

1. Inspect the reverse input clutch housing and drum assembly for the following conditions:
 - Damaged or worn bushings

- Surface finish on the hub and outer housing - check band surface for flatness
- Leak at the weld
- Heat distortion
- Rolled or distorted retaining ring groove

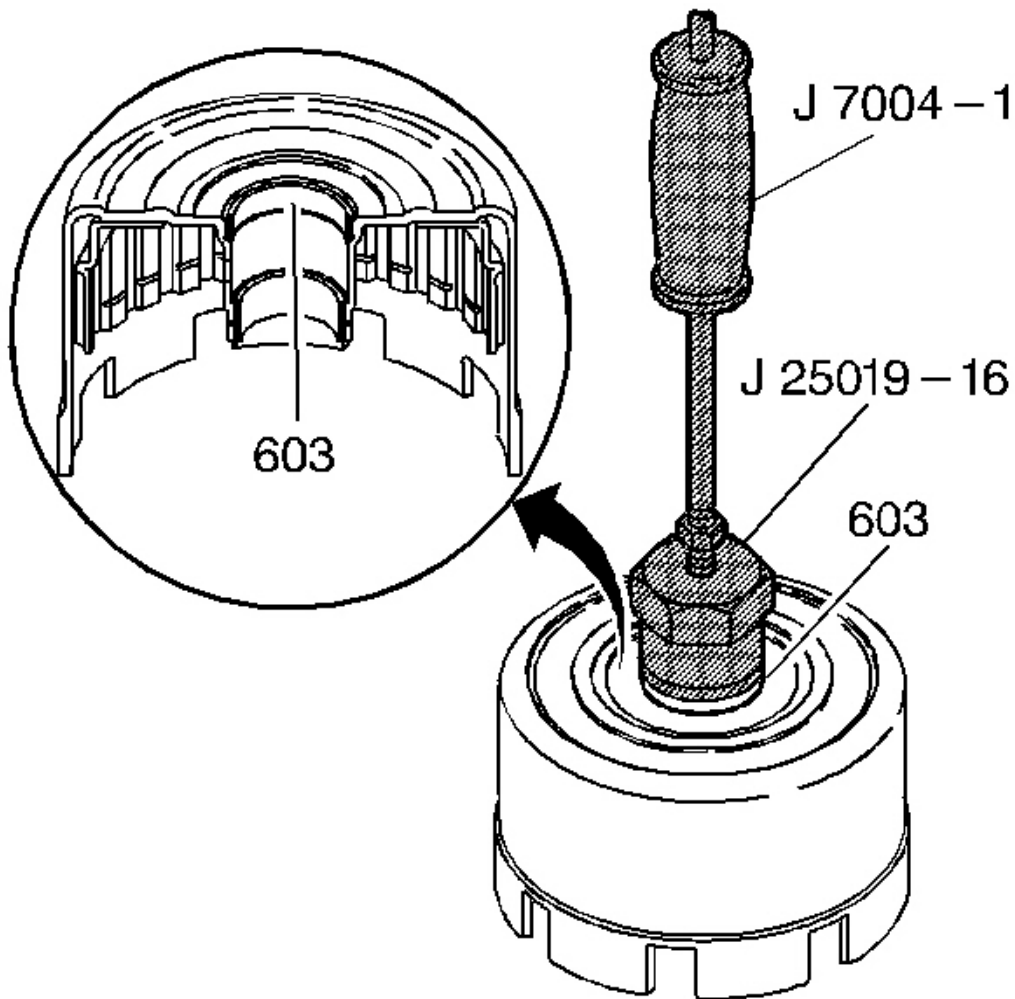

Fig. 354: Identifying Reverse Input Clutch Front Bushing
Courtesy of GENERAL MOTORS CORP.

2. Using the J 25019-16 with the J 7004-A , remove the reverse input clutch front bushing

(603). See **Special Tools**.

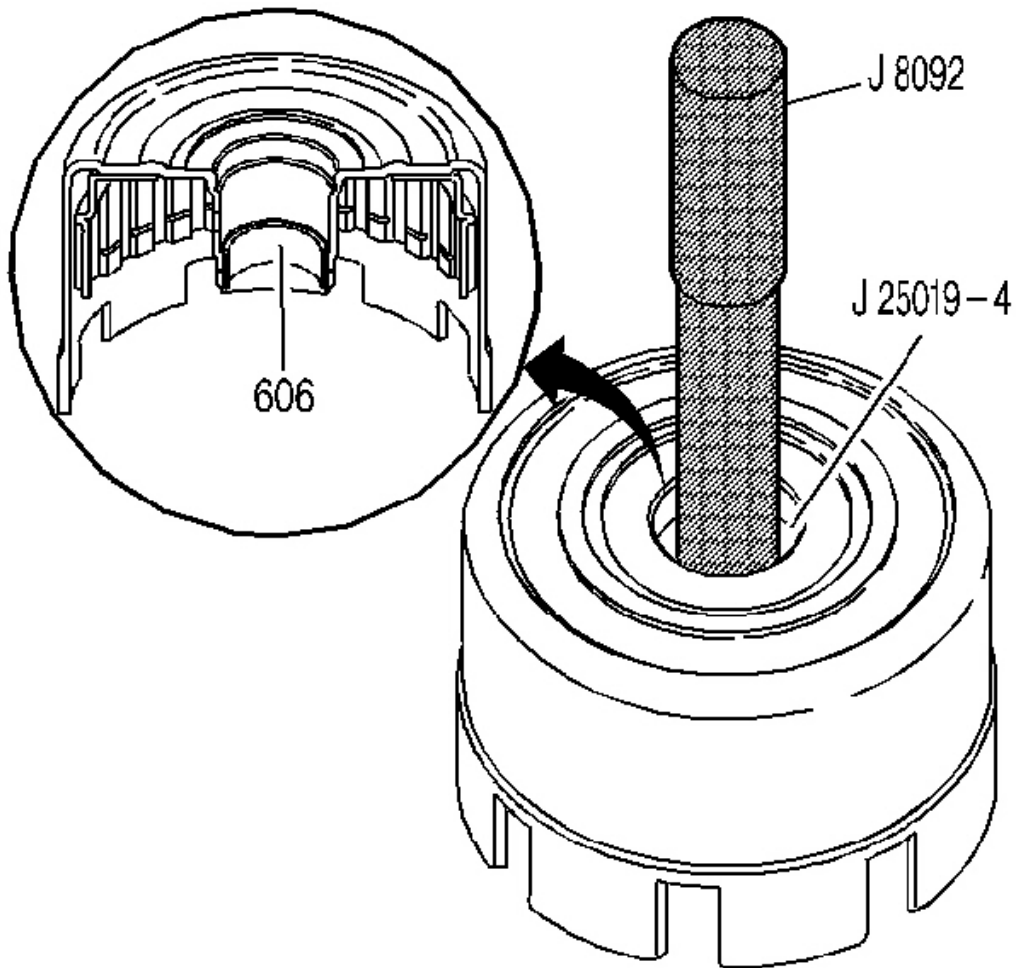

Fig. 355: Locating Reverse Input Clutch Rear Bushing
Courtesy of GENERAL MOTORS CORP.

- Using the J 25019-4 with the J 8092 , remove the reverse input clutch rear bushing (606). See **Special Tools**.

Installation Procedure

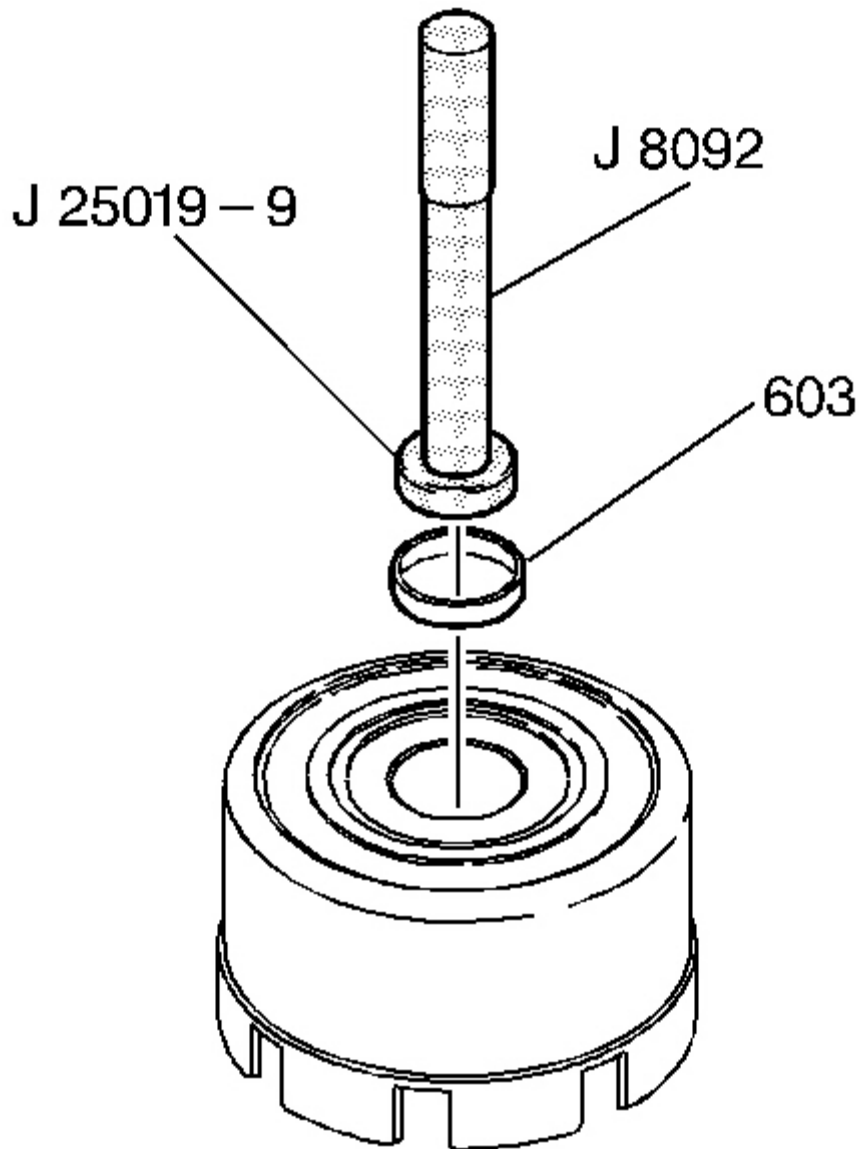

Fig. 356: View Of Reverse Input Clutch Front Bushing
Courtesy of GENERAL MOTORS CORP.

1. Using the **J 25019-9** with the **J 8092** , install a reverse input clutch front bushing (603). See **Special Tools**.

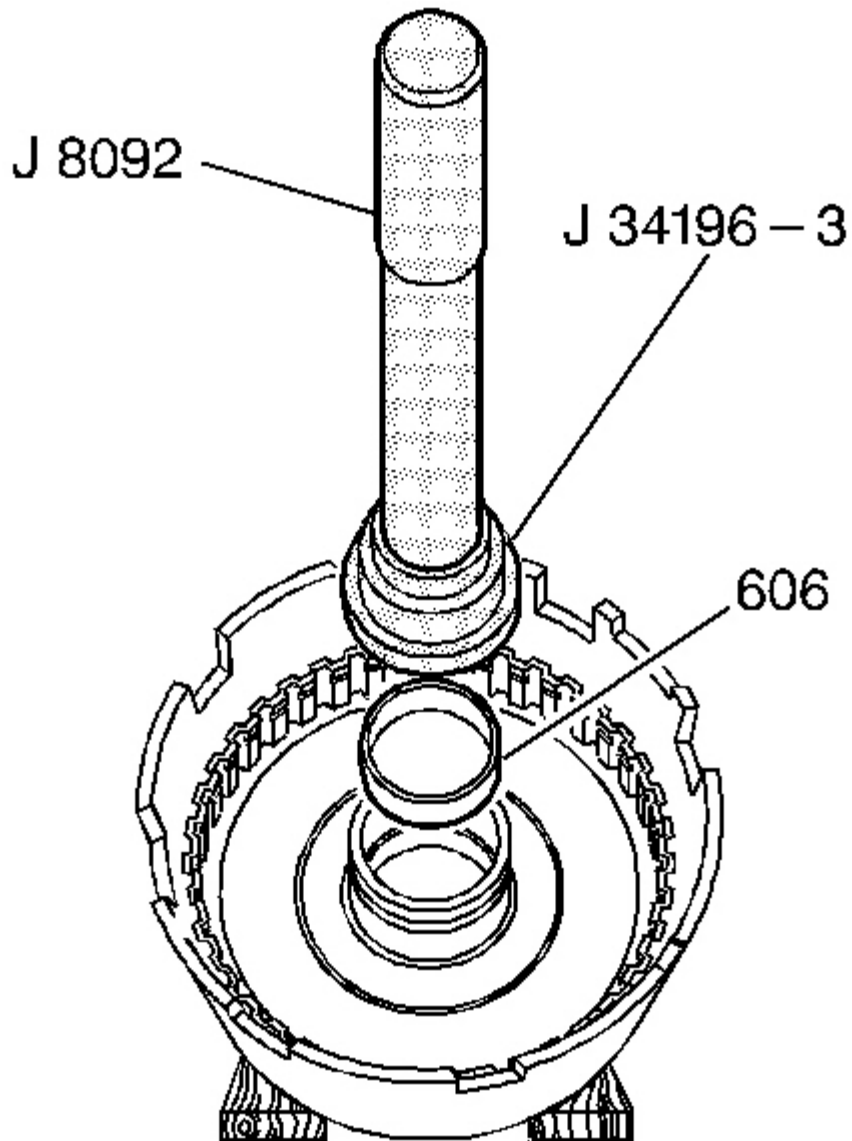

Fig. 357: Installing Reverse Input Clutch Rear Bushing
Courtesy of GENERAL MOTORS CORP.

2. Using the J 34196-3 which is part of kit J 34196-B with the J 8092 , install a reverse input clutch rear bushing (606). See **Special Tools**.

REVERSE INPUT CLUTCH ASSEMBLE**Tools Required**

- **J 23327-1** Forward Clutch Spring Compressor (Bridge). See **Special Tools**.
- **J 25018-A** Clutch Spring Compressor Adapter. See **Special Tools**.
- **J 44571-1** Reverse Input Clutch Piston Installer. See **Special Tools**.

Assembly Procedure

Fig. 358: Locating Inspection Areas On Reverse Input Clutch Piston
Courtesy of GENERAL MOTORS CORP.

1. Inspect the reverse input clutch piston (607) for the following:
 - Damaged or porosity
 - Ring groove damage
2. Install the reverse input clutch inner and outer seals (608) on the piston.

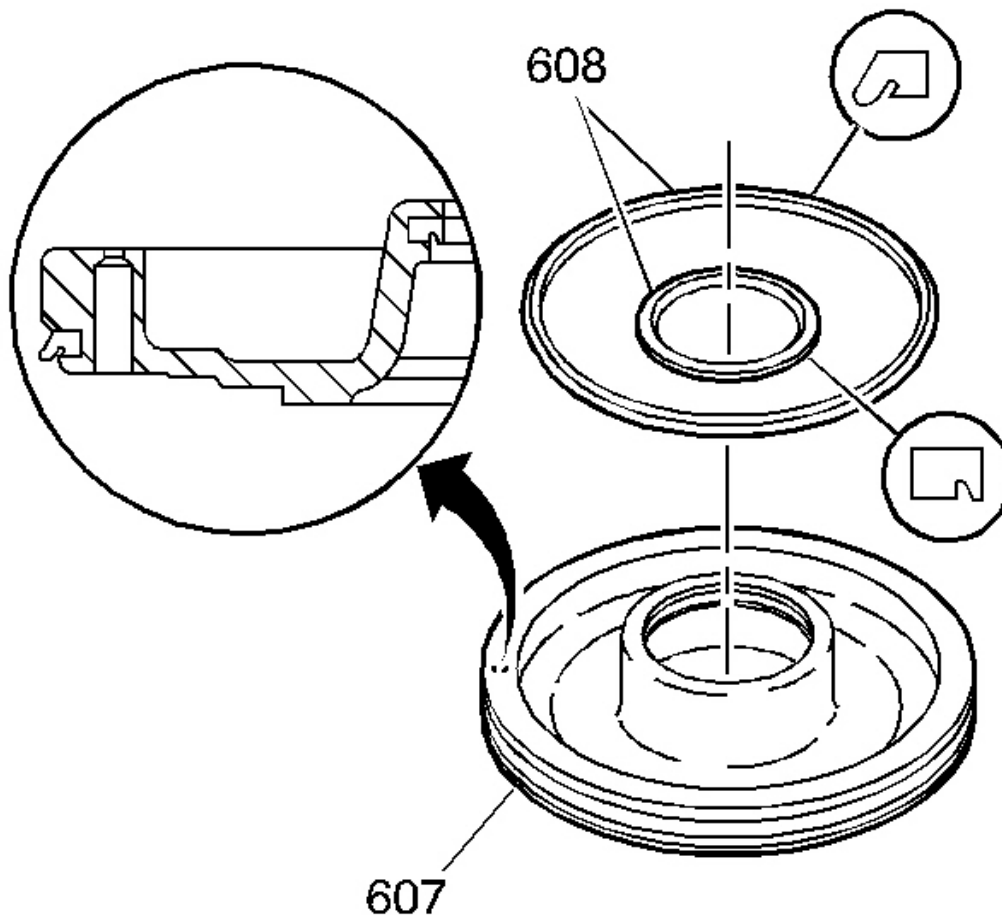
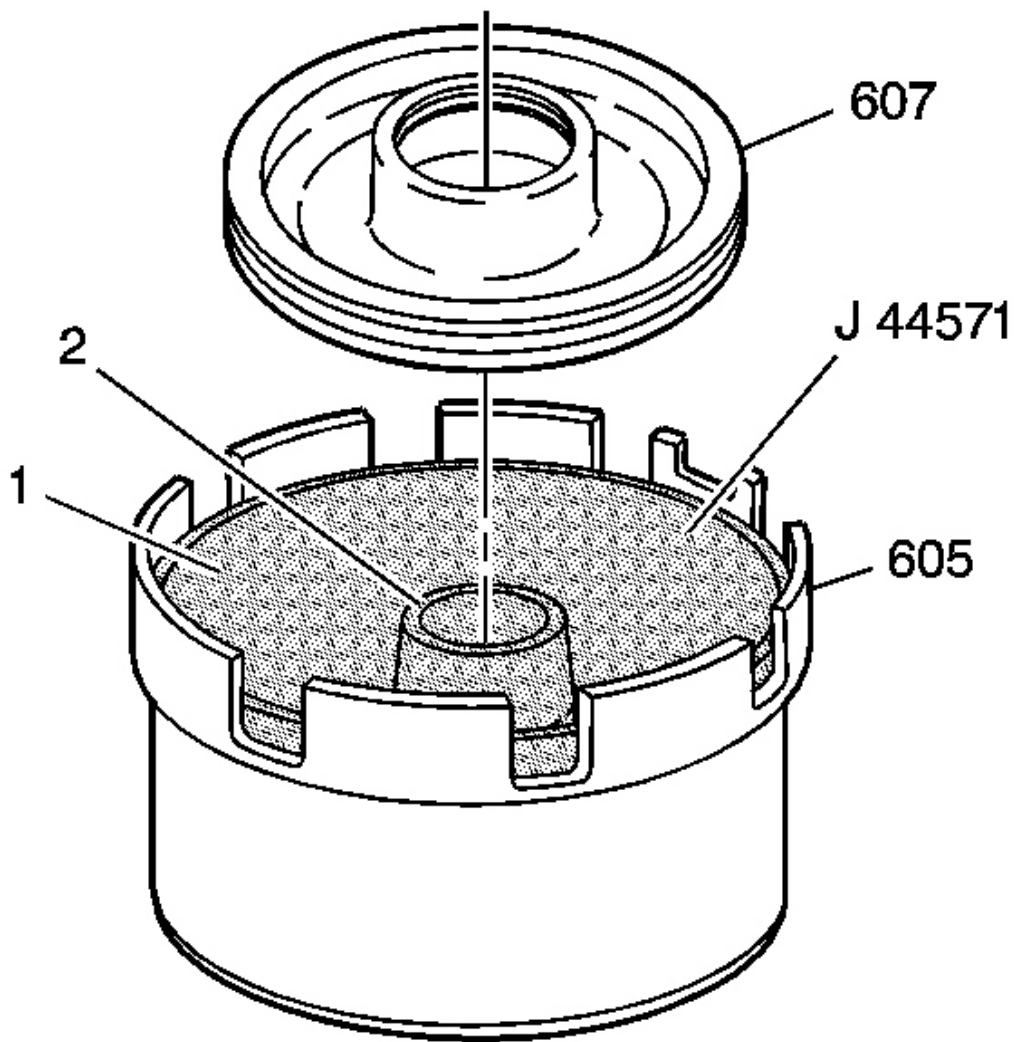

Fig. 359: View Of J 44571-1
Courtesy of GENERAL MOTORS CORP.

3. Install the **J 44571-1** inner (2) and outer (1) reverse input clutch piston installer. See **Special Tools**.
4. Install the piston (607 into the housing (605).
5. Remove the **J 44571-1** . See **Special Tools**.

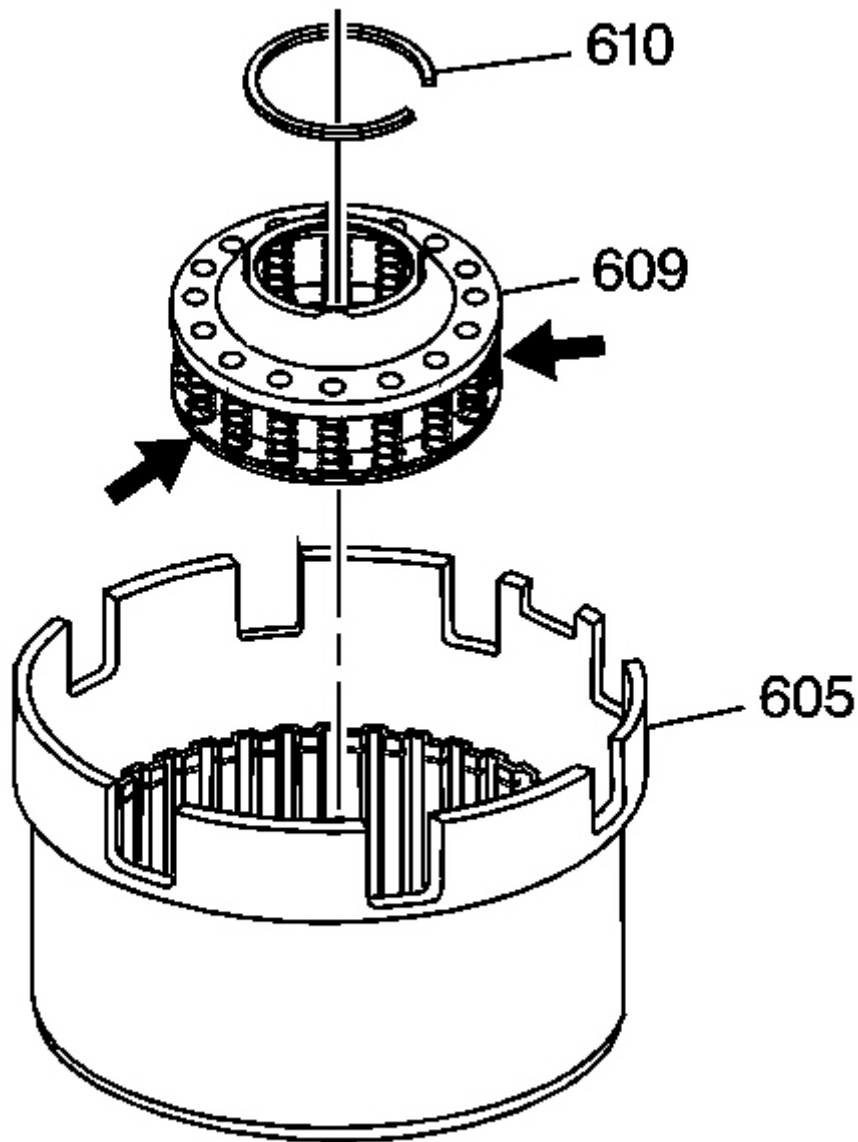

Fig. 360: Identifying Reverse Input Clutch Spring Assembly
Courtesy of GENERAL MOTORS CORP.

6. Inspect the reverse input clutch spring assembly (609) for bent, broken, distorted or damaged springs.
7. Install the reverse input clutch spring assembly (609).

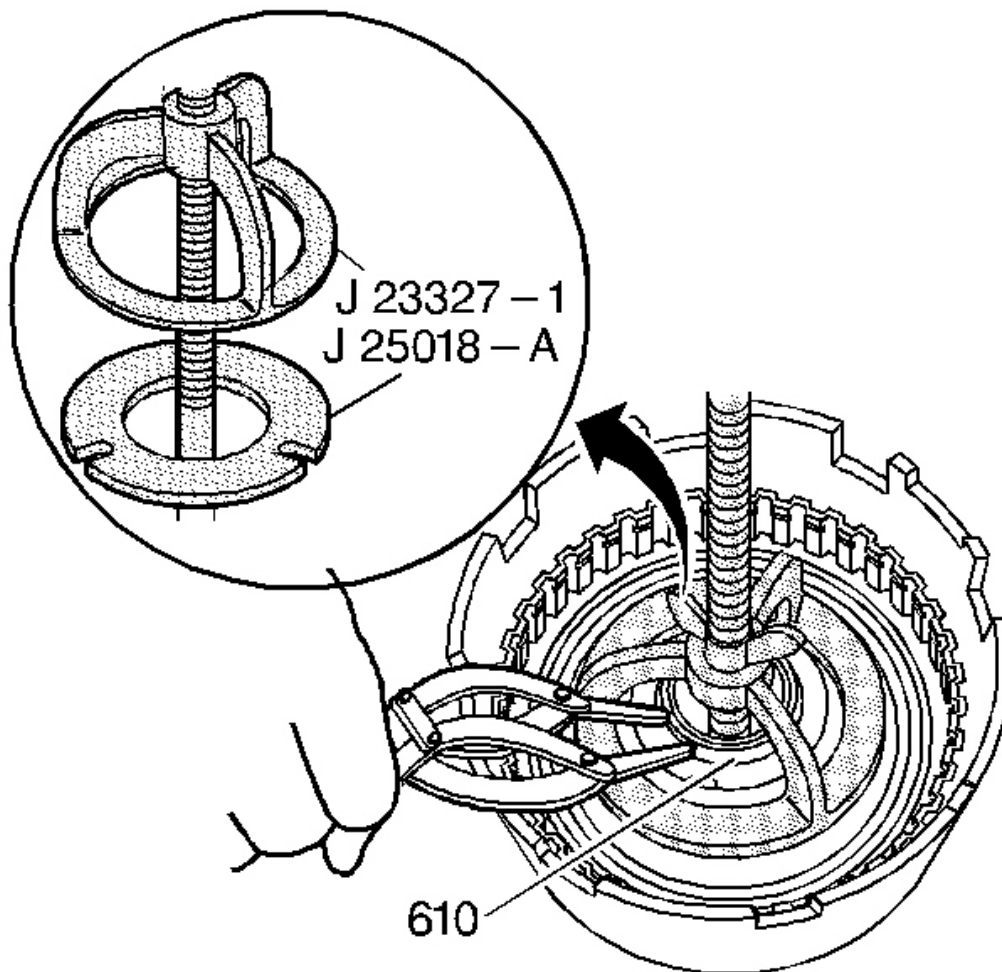

Fig. 361: View Of Reverse Input Clutch Spring Retainer Ring
Courtesy of GENERAL MOTORS CORP.

8. Install the **J 23327-1** and the **J 25018-A** . See **Special Tools**.

9. Install the reverse input clutch spring retainer ring (610).

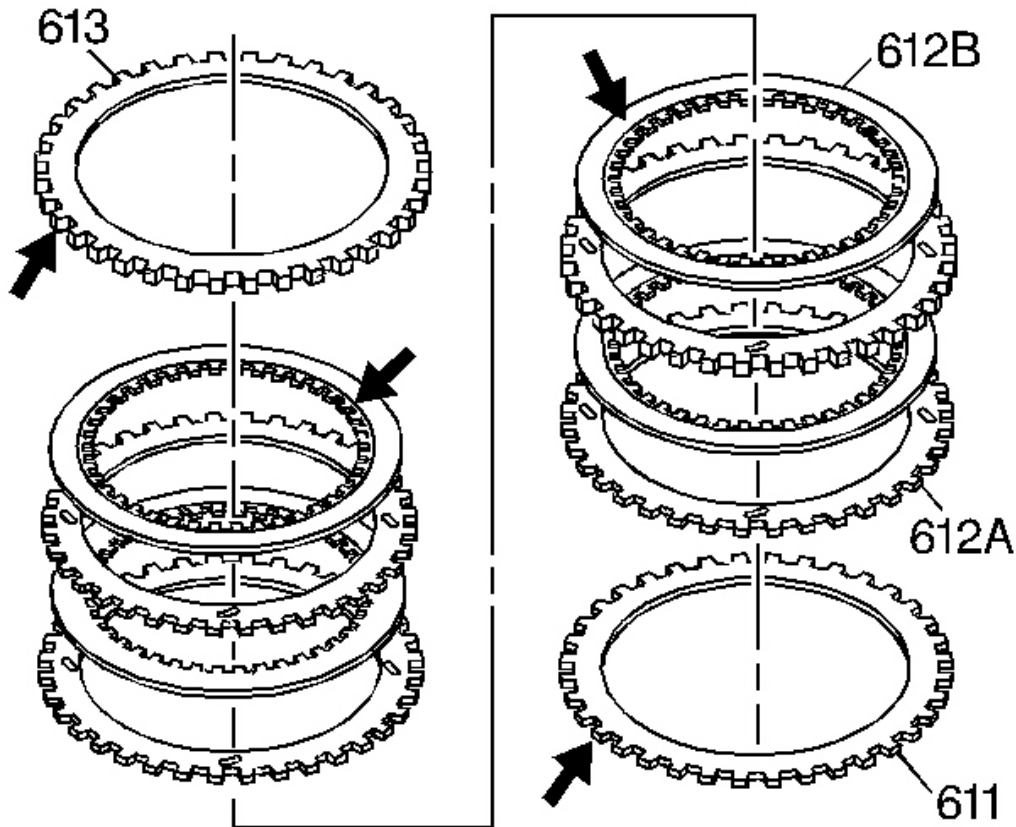

Fig. 362: Inspecting Plates For Damage Or Wear
Courtesy of GENERAL MOTORS CORP.

10. Inspect the belleville plate (611), the fiber plate assemblies (612B), the steel turbulator plates (612A) and the selective backing plate (613) for the following items:

- Damaged tangs
- Delamination
- Excessive wear
- Heat damage or wear
- Surface finish
- Flatness

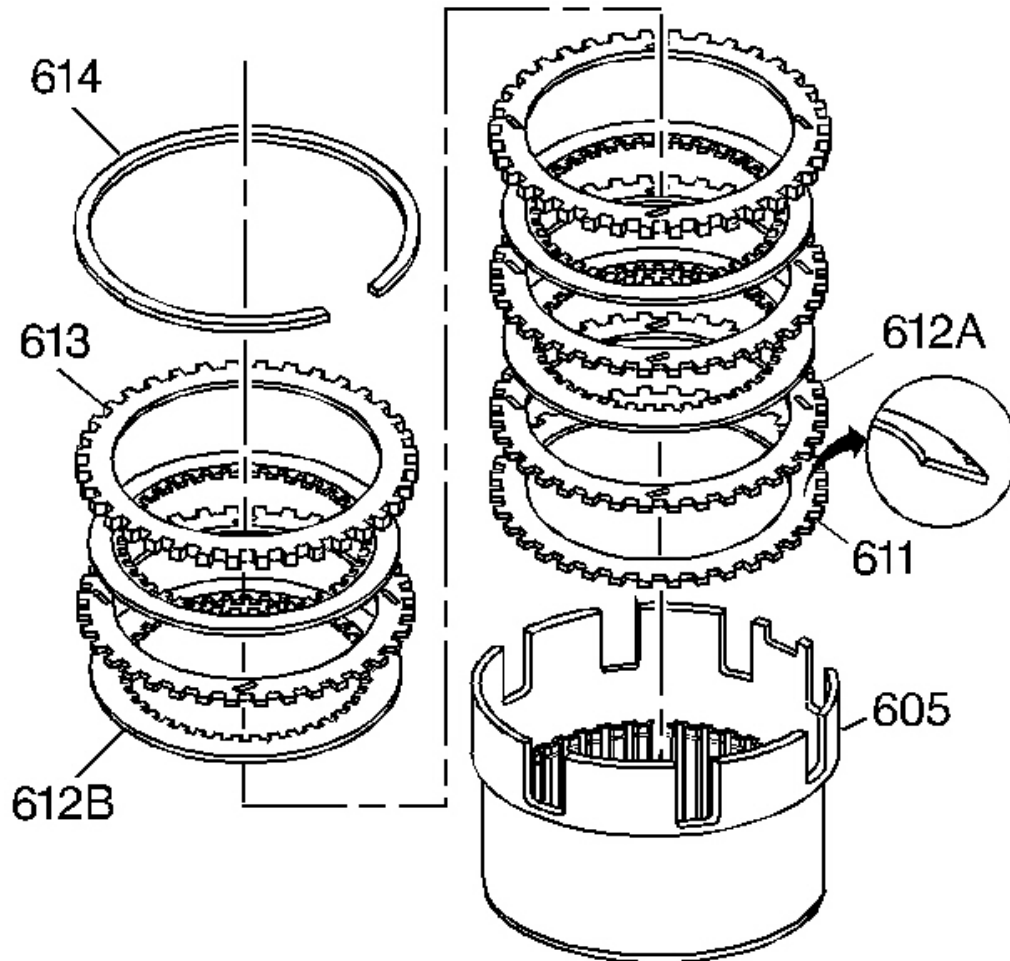

Fig. 363: Locating Reverse Input Clutch Plates
 Courtesy of GENERAL MOTORS CORP.

11. Install the reverse input clutch bellville plate (611), with the inner diameter up, into the reverse input clutch housing and drum assembly (605).
12. Install the reverse input clutch plates starting with a steel turbulator plate (612A) and alternate with a fiber plate assembly (612B).
13. Install the reverse input clutch selective backing plate (613).
14. Install the reverse input clutch retaining ring (614).

REVERSE INPUT CLUTCH PLATE TRAVEL CHECK

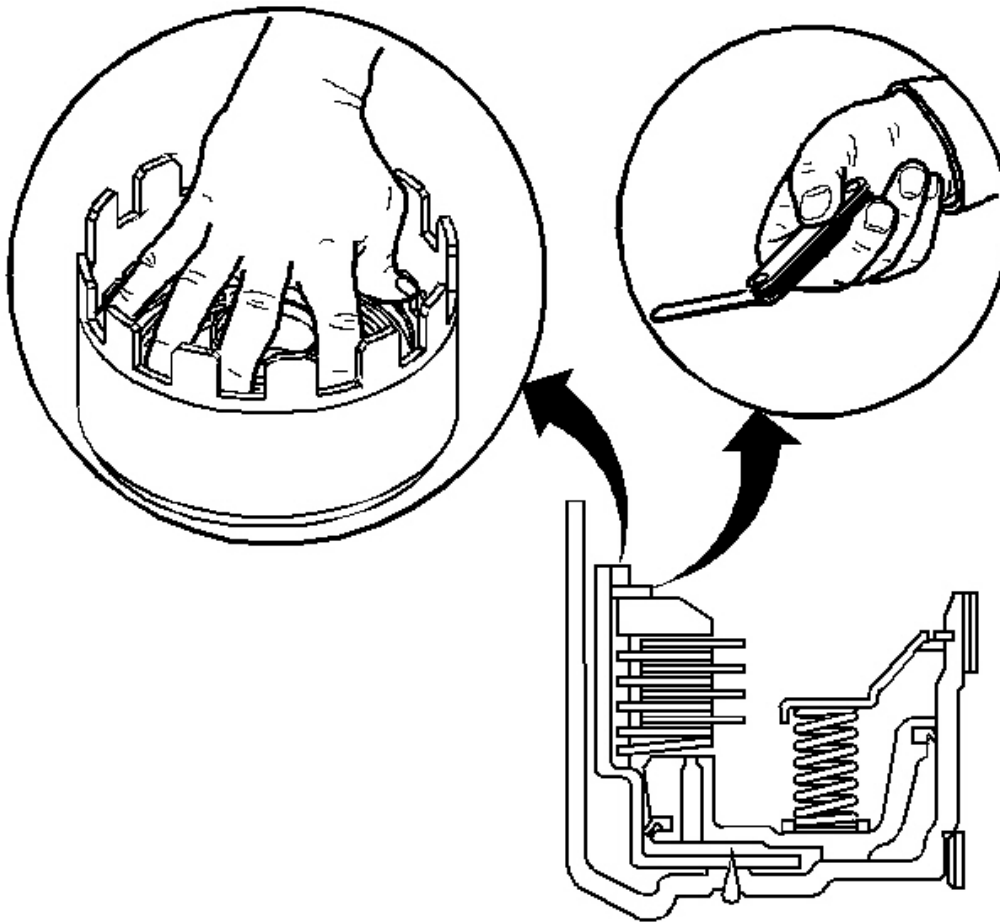

Fig. 364: Checking Reverse Input Clutch Plate Travel
Courtesy of GENERAL MOTORS CORP.

1. Apply an evenly distributed load to the clutch pack.
2. Use feeler gages to check the reverse input clutch plate travel.
3. Check the travel between the selective backing plate and the reverse input clutch retainer ring.

Clutch Plate Travel Specifications: The reverse input clutch plate travel should be 1.02-2.01 mm (0.040-0.079 in).

4. Select the proper selective backing plate to obtain the correct travel. Refer to **Reverse**

Input Clutch Backing Plate Selection .

REVERSE INPUT AND 3-4 CLUTCH HOUSING INSTALLATION

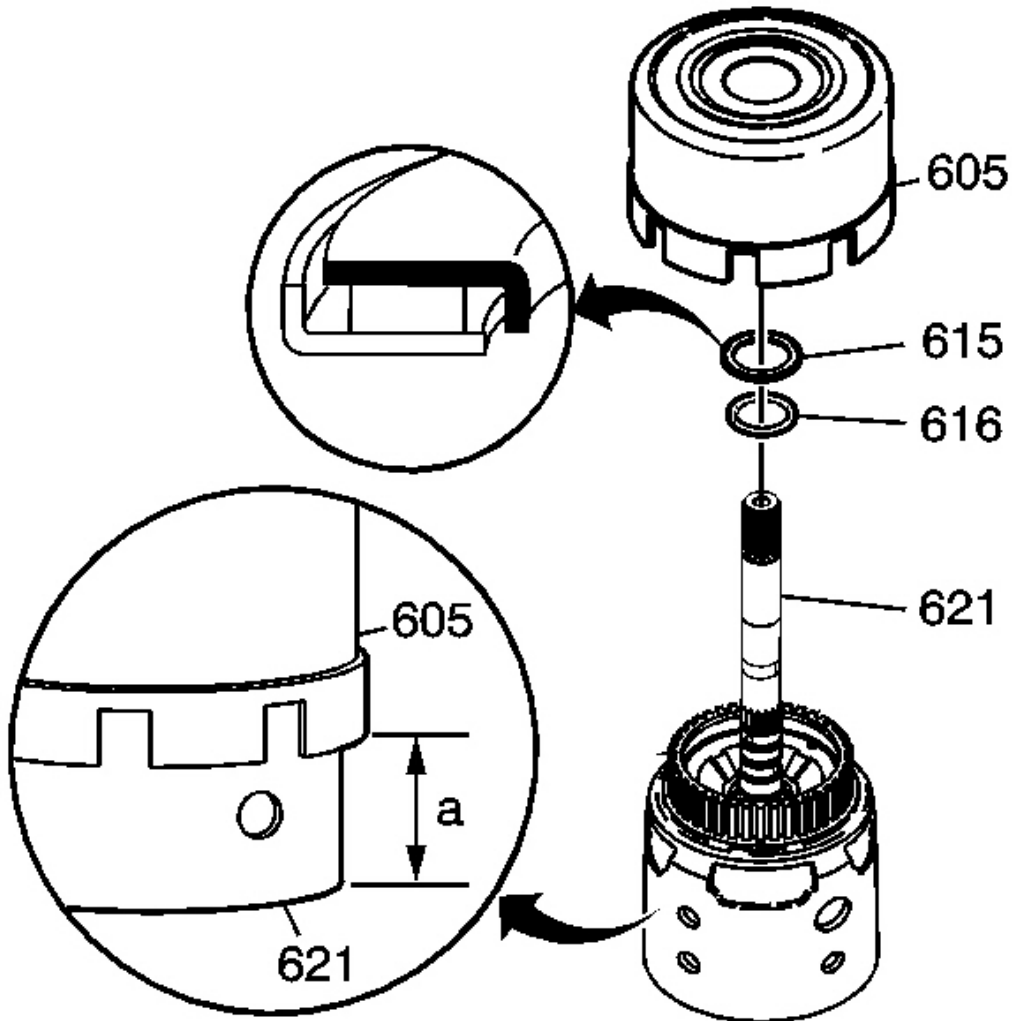

Fig. 365: View Of Clutch Housing Components
Courtesy of GENERAL MOTORS CORP.

1. Install the selective thrust washer (616) on the input housing (621).
2. Install the stator shaft/selective washer bearing assembly (615) on the input housing (621).

The black race on the bearing goes toward the oil pump - facing up.

3. Install the reverse input clutch assembly (605) on the input housing (621).
4. Index the reverse input clutch plates with the input clutch housing. Make certain all reverse input clutch plates are fully engaged. When fully engaged, the housings will be 88.9 mm (3.5 in) apart as shown (a).

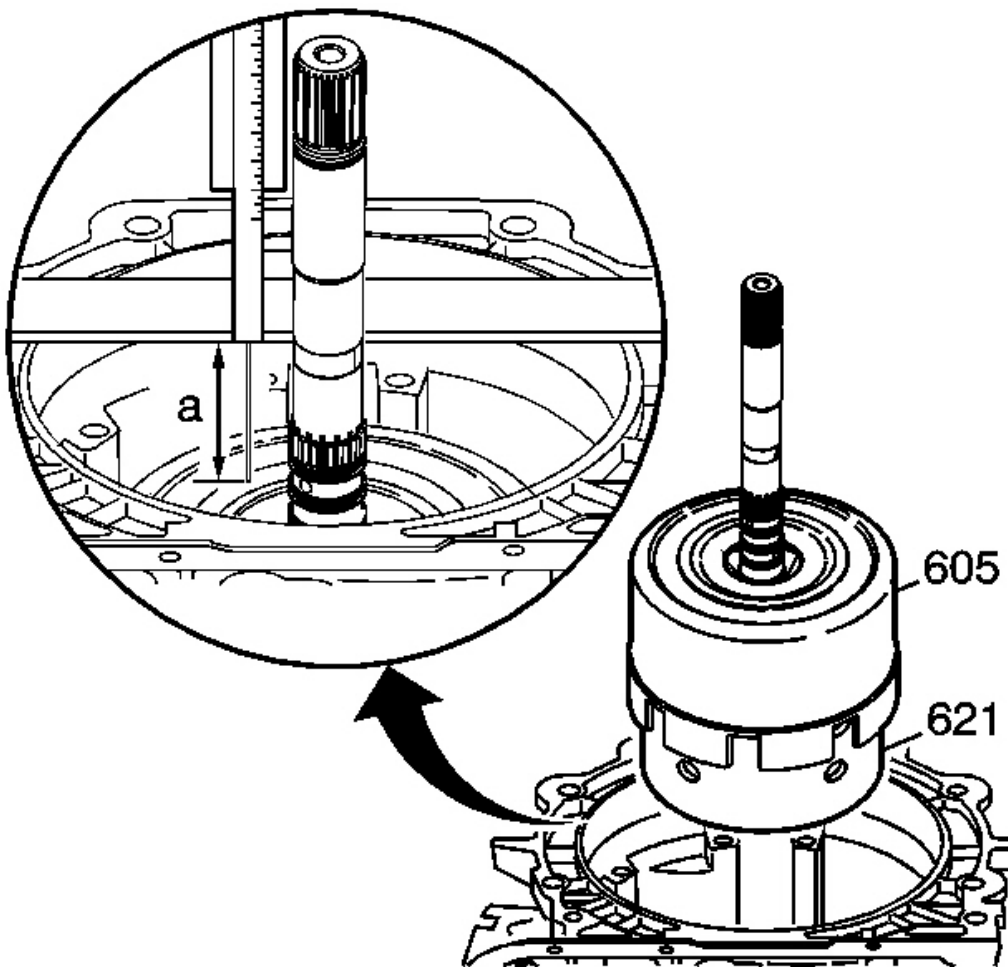

Fig. 366: View of Input Clutch Assembly & Input Housing
Courtesy of GENERAL MOTORS CORP.

5. Install the reverse input and the input clutch assembly into the transmission case.

2007 Hummer H3

2007 TRANSMISSION Automatic Transmission - 4L60-E/4L65-E/4L70-E - H3

6. Index the 3rd and 4th clutch plates with the input internal gear.
 - Ensure that all clutch plates are fully engaged.
 - When properly assembled, the reverse input clutch housing will be located just below the case oil pump mounting face.
 - To assist assembly, hold the output shaft while rotating the input housing.

IMPORTANT: The measurement from the top of the case to the top of the input clutch assembly is approximate.

7. Measure (a) from the top of the case to the top of the input clutch assembly (605). When fully engaged, the distance will be approximately 61.0 mm (2.40 in).

If the measurement is out of specification, you may not have all of the 3rd and 4th clutch plates indexed accurately.

2-4 BAND ASSEMBLY INSTALLATION

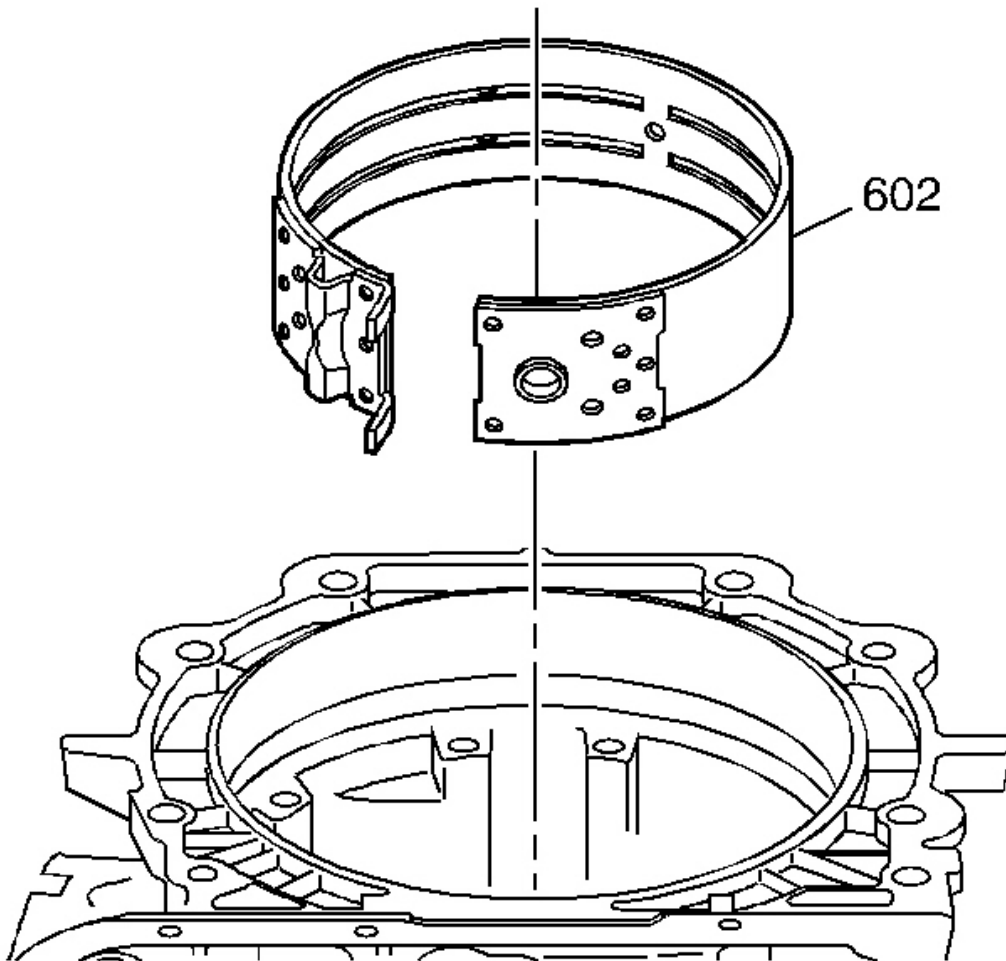

Fig. 367: View Of 2-4 Band Assembly
Courtesy of GENERAL MOTORS CORP.

1. Inspect the 2-4 band assembly (602) for damage or wear.
2. Install the 2-4 band (602) into the case.

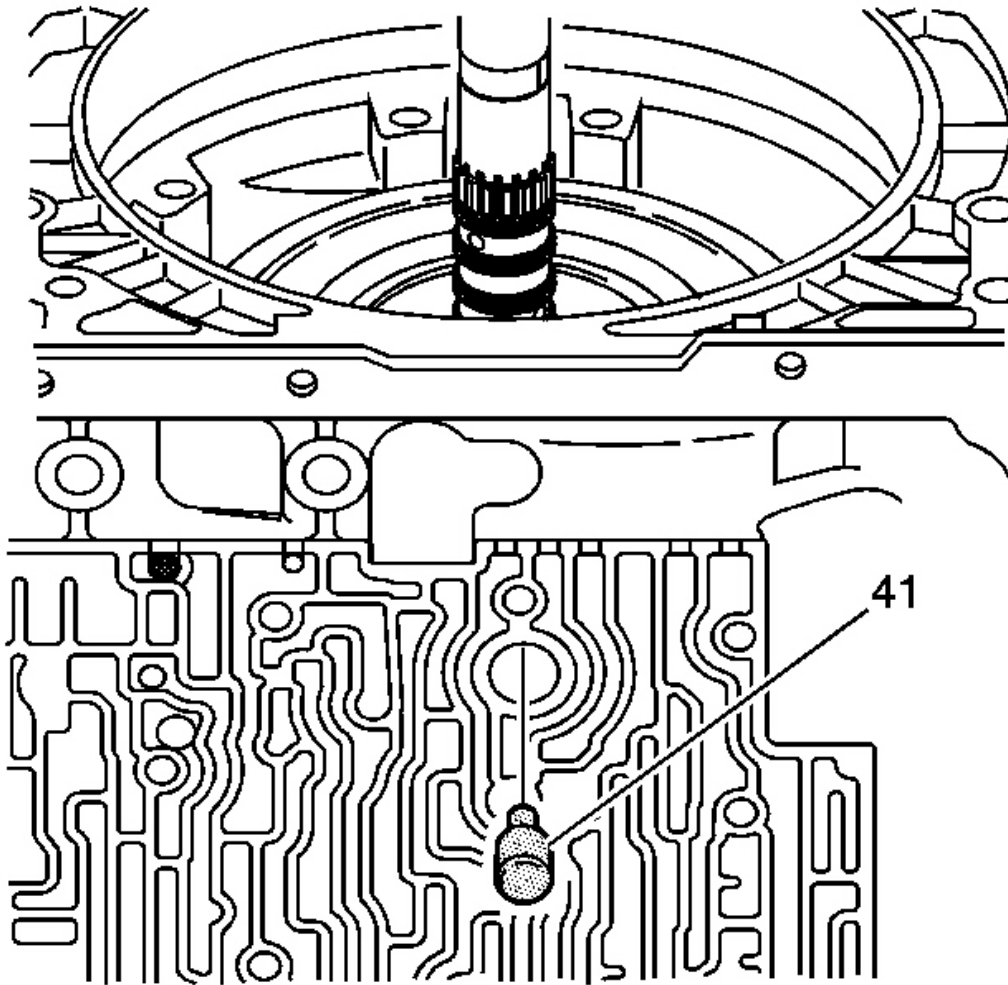

Fig. 368: Identifying Band Anchor Pin
Courtesy of GENERAL MOTORS CORP.

3. Install the band anchor pin (41) into the case.
4. Index the band to fit the band anchor pin into the band.

OIL PUMP DISASSEMBLE

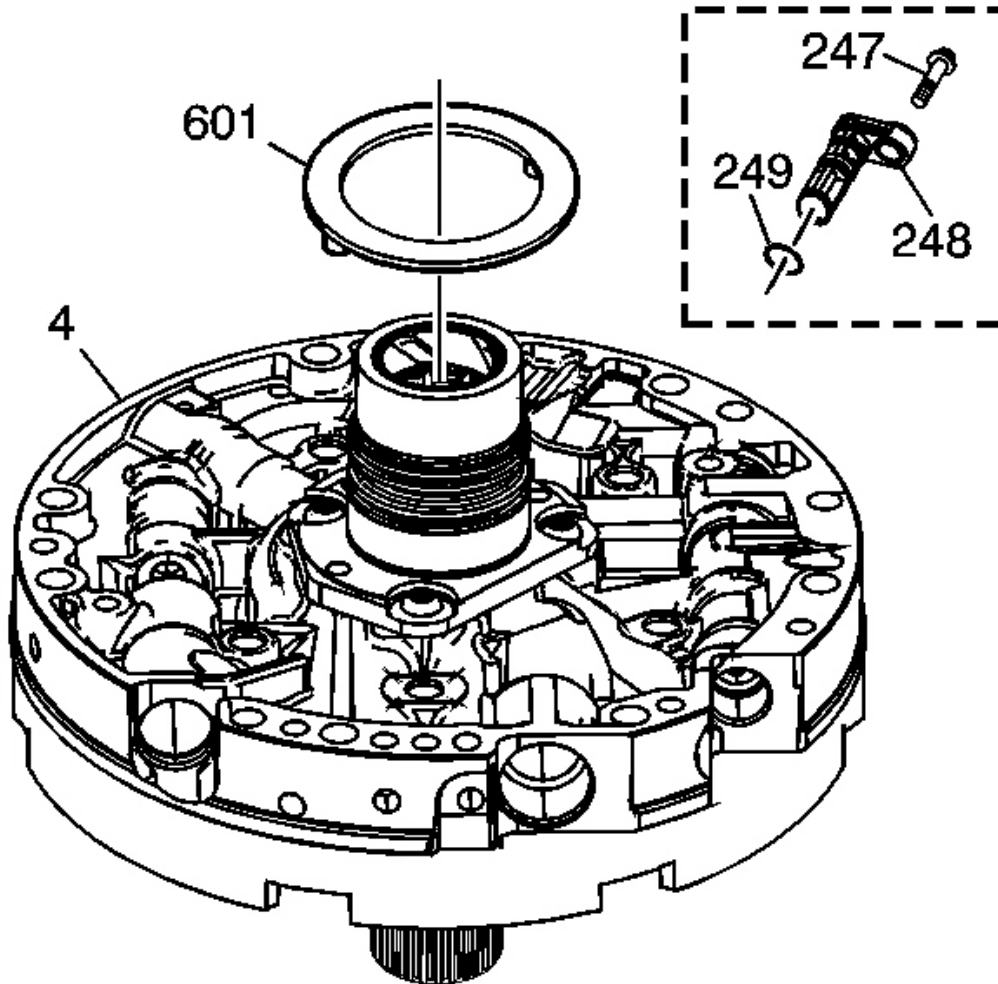

Fig. 369: Identifying Oil Pump Thrust Washer
Courtesy of GENERAL MOTORS CORP.

1. Remove the thrust (pump to drum) washer (601).
2. For pump assemblies with an ISS hole plug (248), remove plug bolt (247) and ISS hole plug (248).
3. Remove the O-ring (249) and discard.

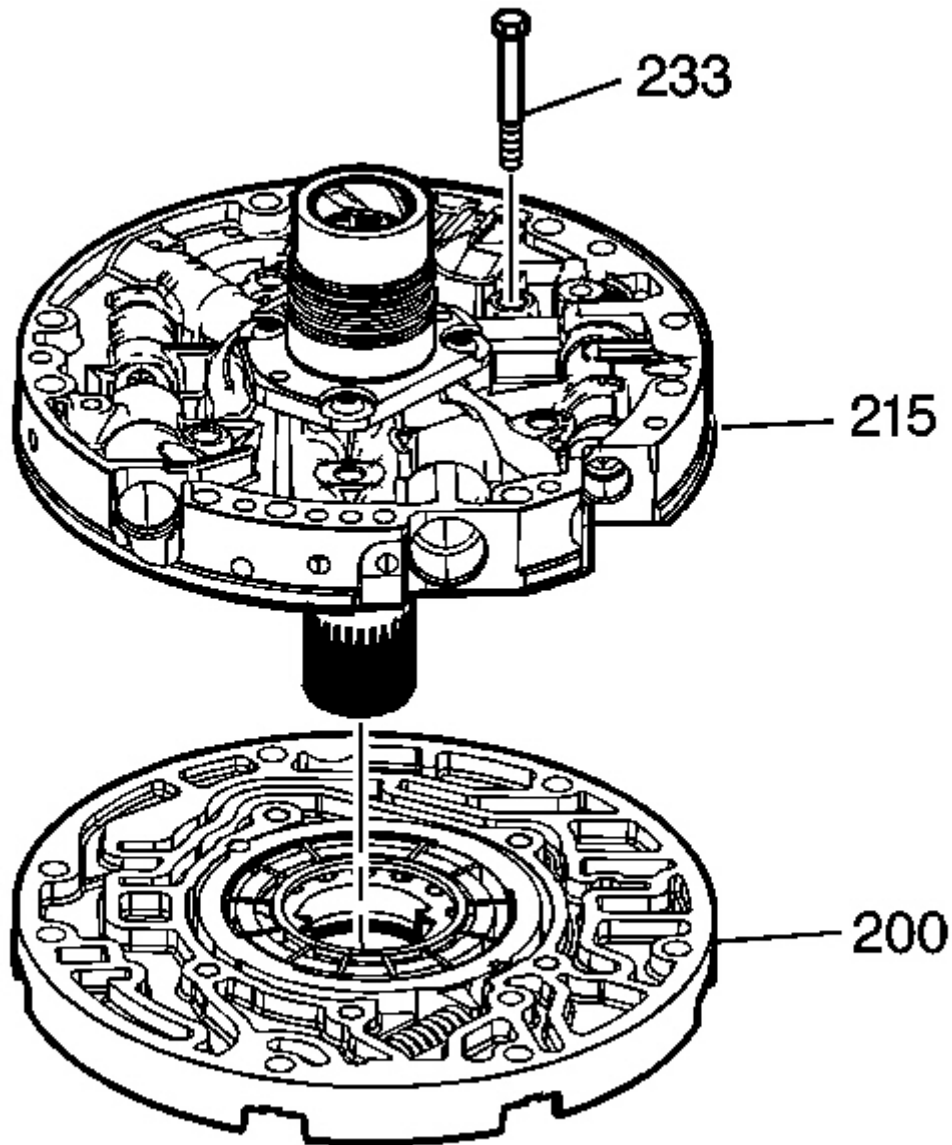

Fig. 370: View Of Oil Pump Cover & Oil Pump Body
Courtesy of GENERAL MOTORS CORP.

4. Remove the pump cover bolts (233).
5. Remove the pump cover (215) from the pump body (200).

OIL PUMP BODY DISASSEMBLE

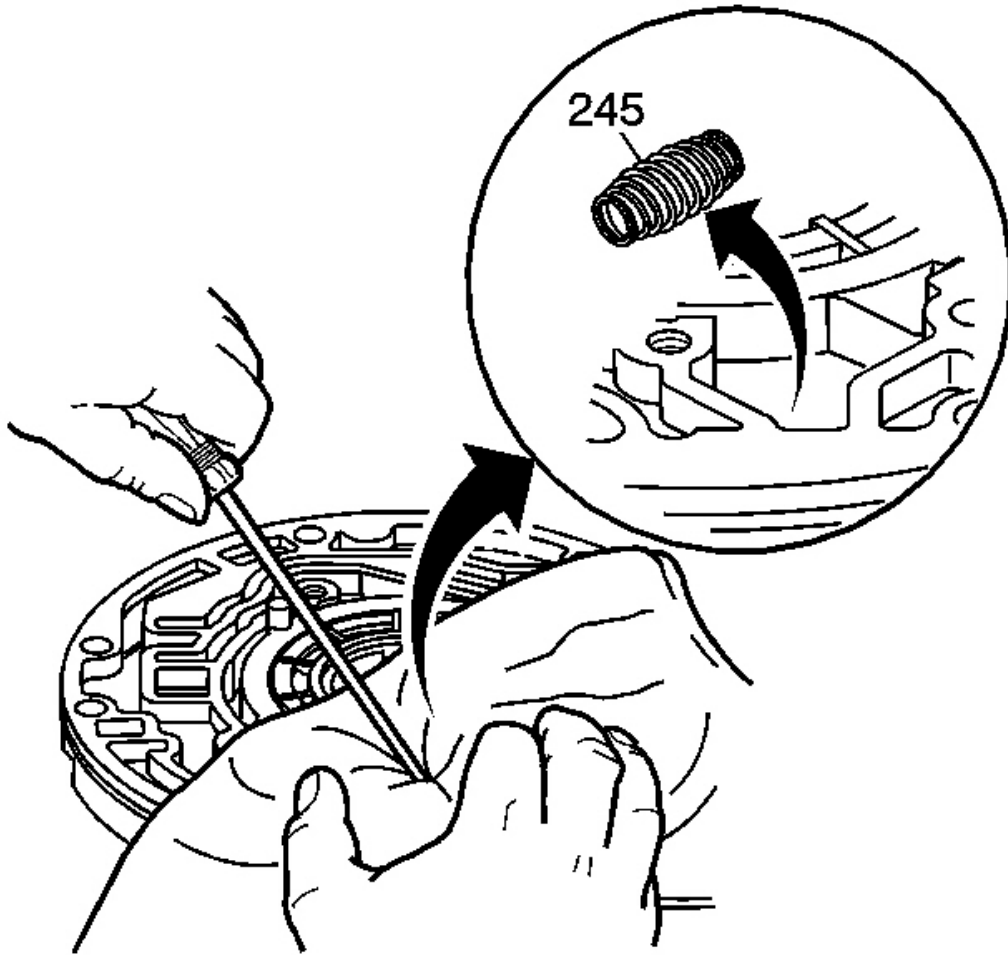

Fig. 371: Removing Pump Slide Outer Spring
Courtesy of GENERAL MOTORS CORP.

1. Remove the pump slide outer spring (245).
2. Place a rag over the spring while removing to prevent the spring from flying out.

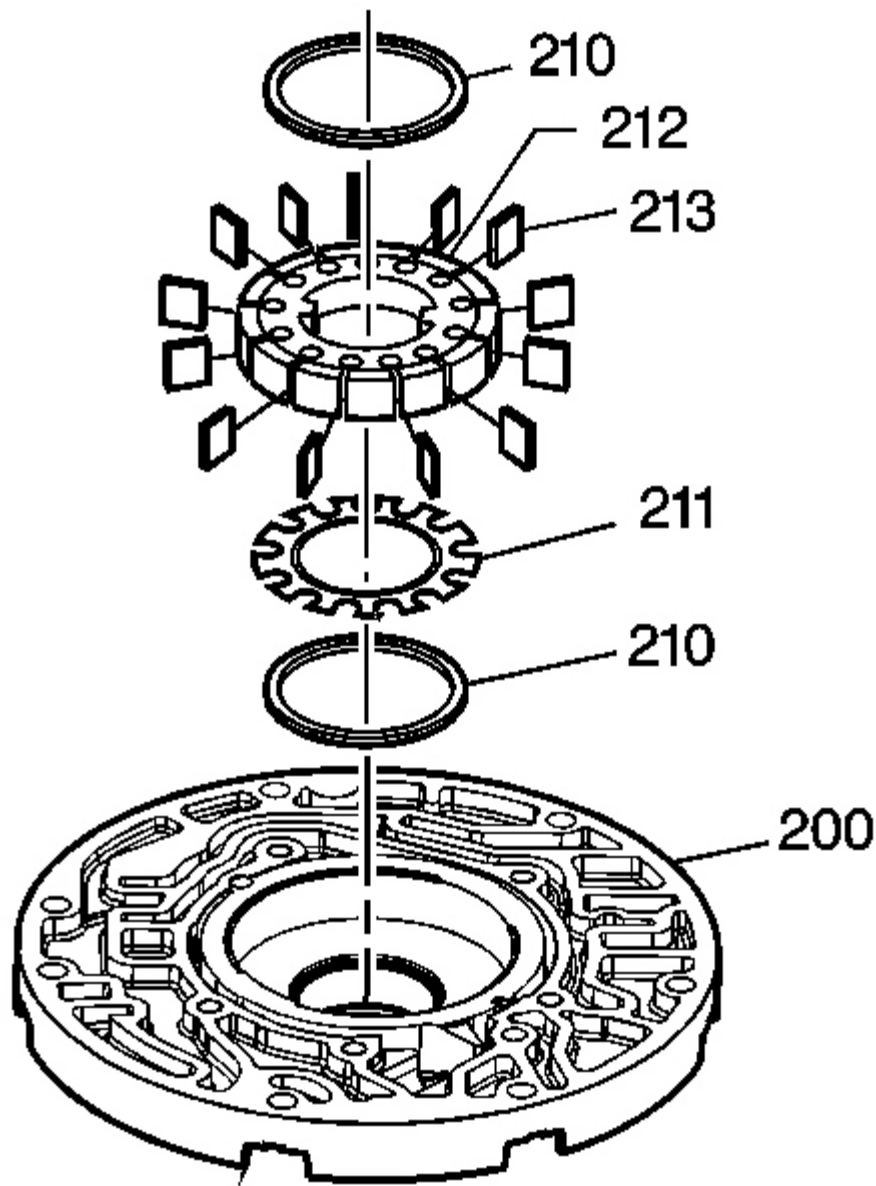

Fig. 372: Identifying Pump Vane Ring, Rotor Guide & Rotor
Courtesy of GENERAL MOTORS CORP.

3. Remove the oil pump rotor (212) and pump vane rings (210).
4. Remove the pump vanes (213).

5. Remove the rotor guide (211).

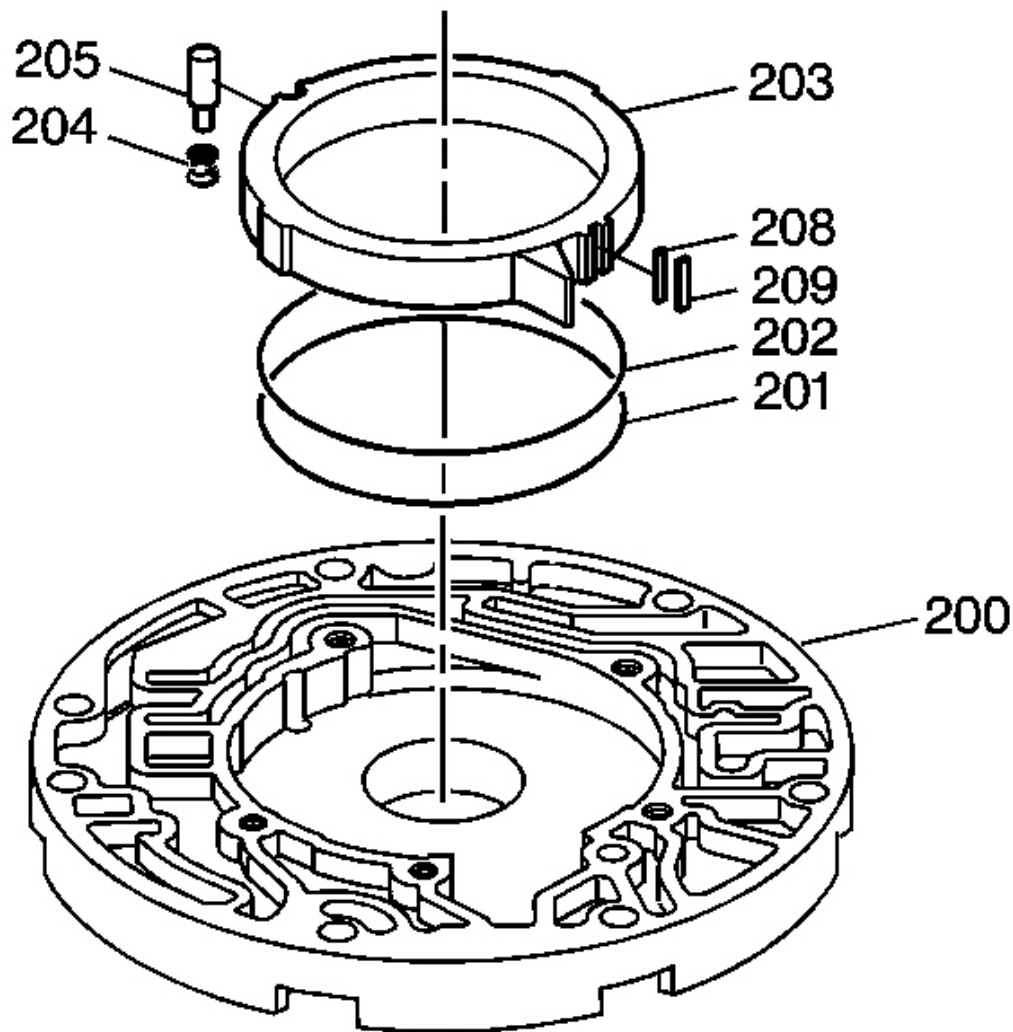

Fig. 373: Identifying Oil Pump Slide, Pump Slide Support Seal & Pump Slide Seal
Courtesy of GENERAL MOTORS CORP.

6. Remove the pump slide (203), pump slide support seal (208) and the pump slide seal (209).
7. Remove the slide seal back-up O-ring seal (202) and the oil seal - slide to wear plate, ring (201).
8. Remove the pivot slide pin (205) and the pivot pin spring (204).

OIL PUMP ROTOR AND SLIDE MEASUREMENT

Fig. 374: Measuring Oil Pump Rotor & Slide
Courtesy of GENERAL MOTORS CORP.

IMPORTANT: Measure the rotor and slide thickness for surface wear. The rotor and slide measurements must both fall into the same thickness range. If the rotor and slide measurements do not fall into the same thickness range or are outside of all the ranges, the oil pump must be replaced as an assembly.

- Refer to Oil Pump Rotor and Slide Measurement .
- Measure the oil pump rotor (212) thickness.
- Measure the oil pump slide (203) thickness.

OIL PUMP BODY BUSHING REPLACEMENT**Tools Required**

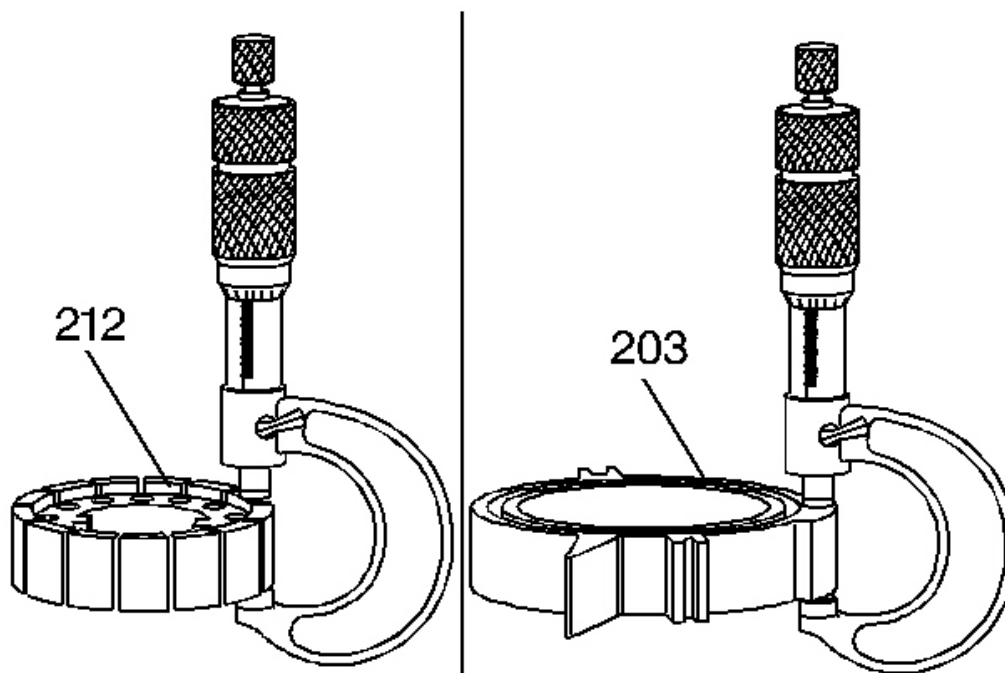
- **J 41778-1** Pump Body Bushing Installer/Remover. See **Special Tools**.
- **J 41778-2** Pump Body Bushing Position Stop. See **Special Tools**.

Procedure

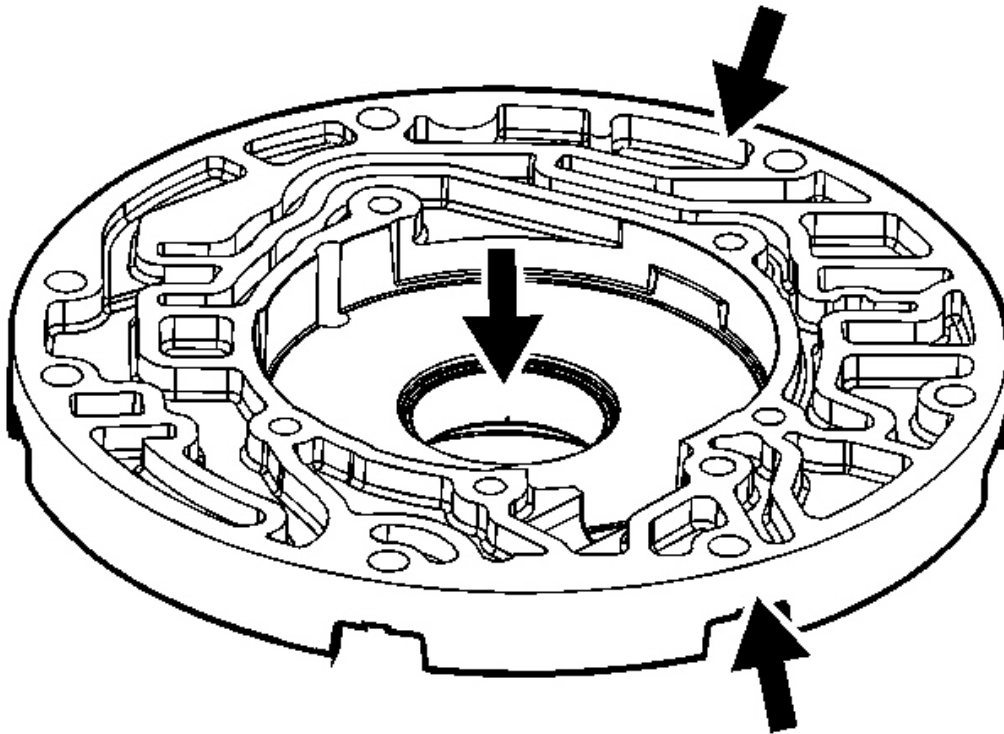

Fig. 375: Inspecting Oil Pump Body
Courtesy of GENERAL MOTORS CORP.

1. Inspect the oil pump body for the following:
 - Worn or damaged bushings
 - Foreign material or debris
 - Porosity
 - Scored or irregular mating faces
 - Cross channel leaks

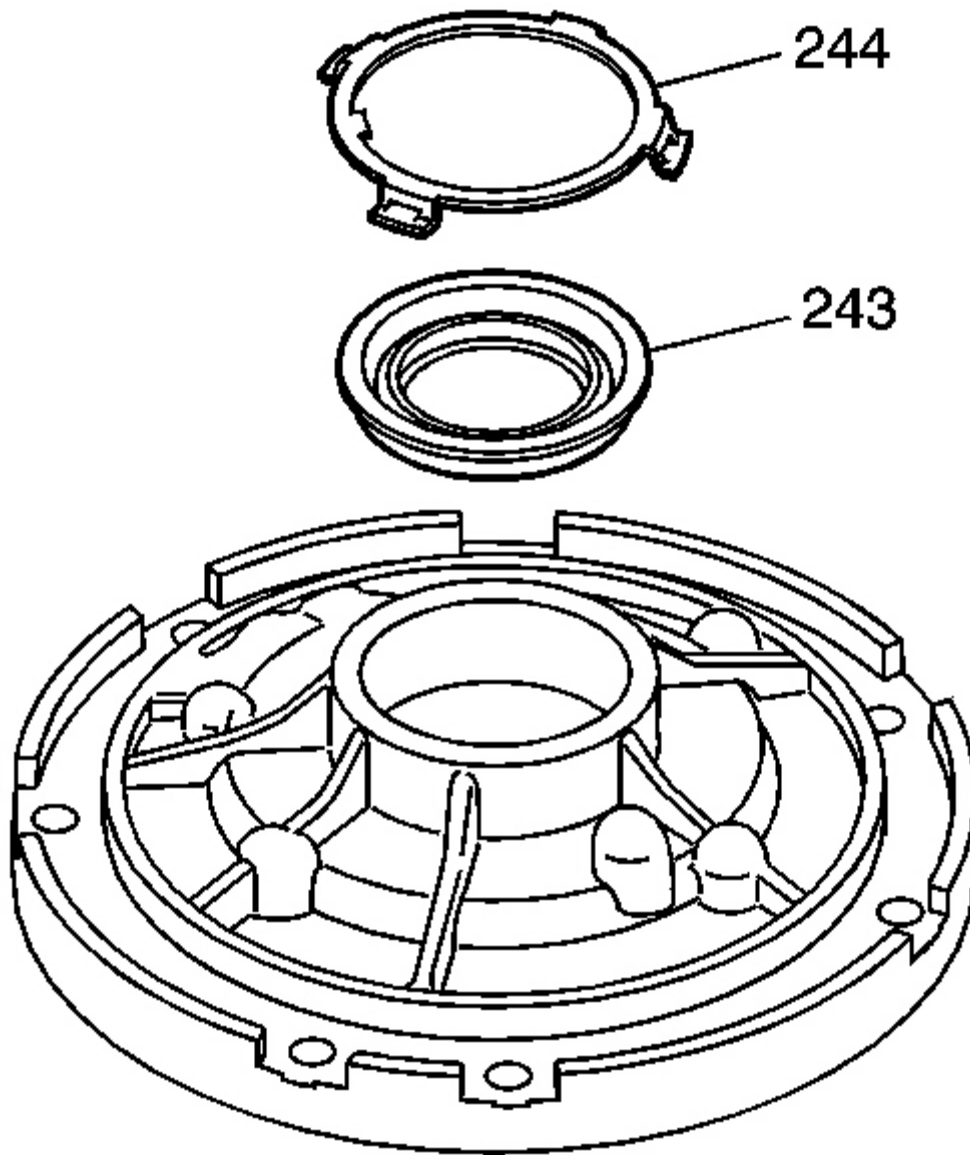

Fig. 376: View Of Front Fluid Seal Retainer & Oil Seal Assembly
Courtesy of GENERAL MOTORS CORP.

2. Remove the front fluid seal retainer (244).
3. Remove the oil seal assembly (243).

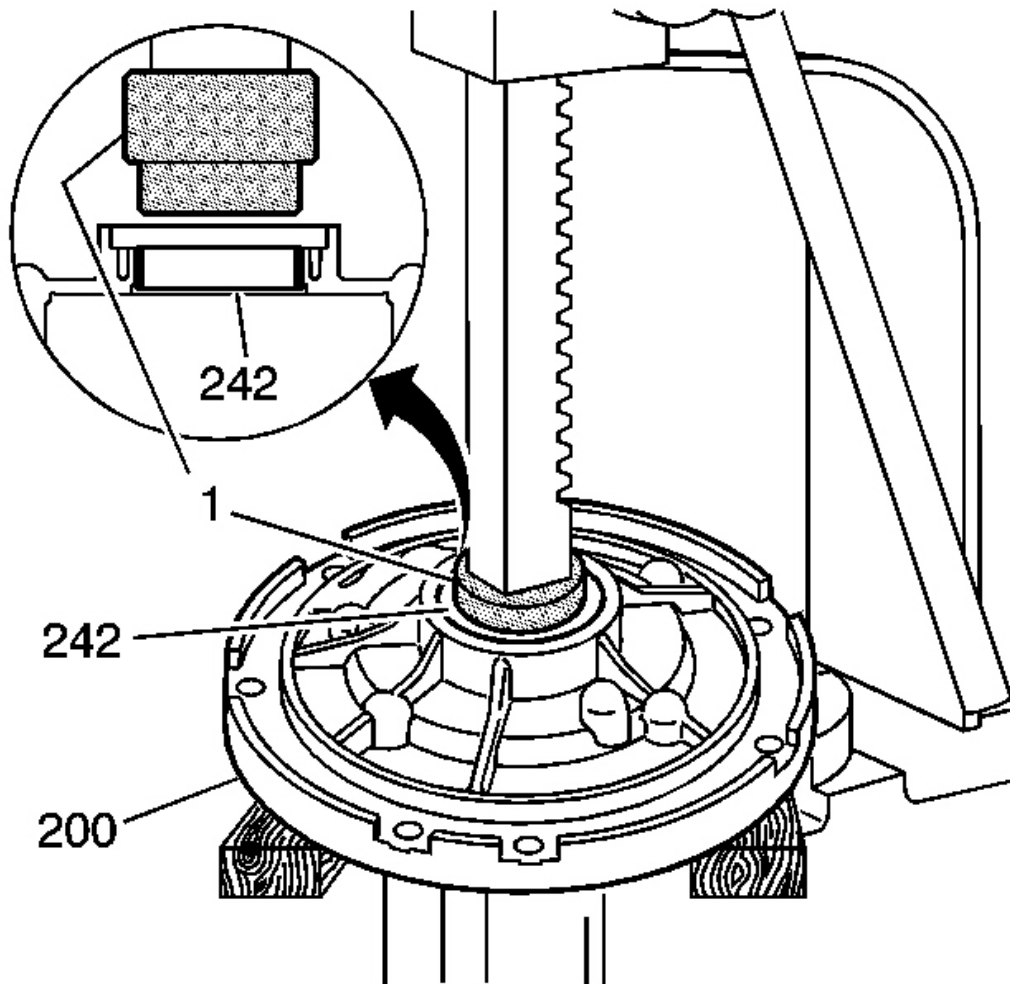

Fig. 377: Identifying Pump Body Bushing
Courtesy of GENERAL MOTORS CORP.

4. Using the **J 41778-1** (1) with an arbor press, remove the pump body bushing (242). See **Special Tools**.

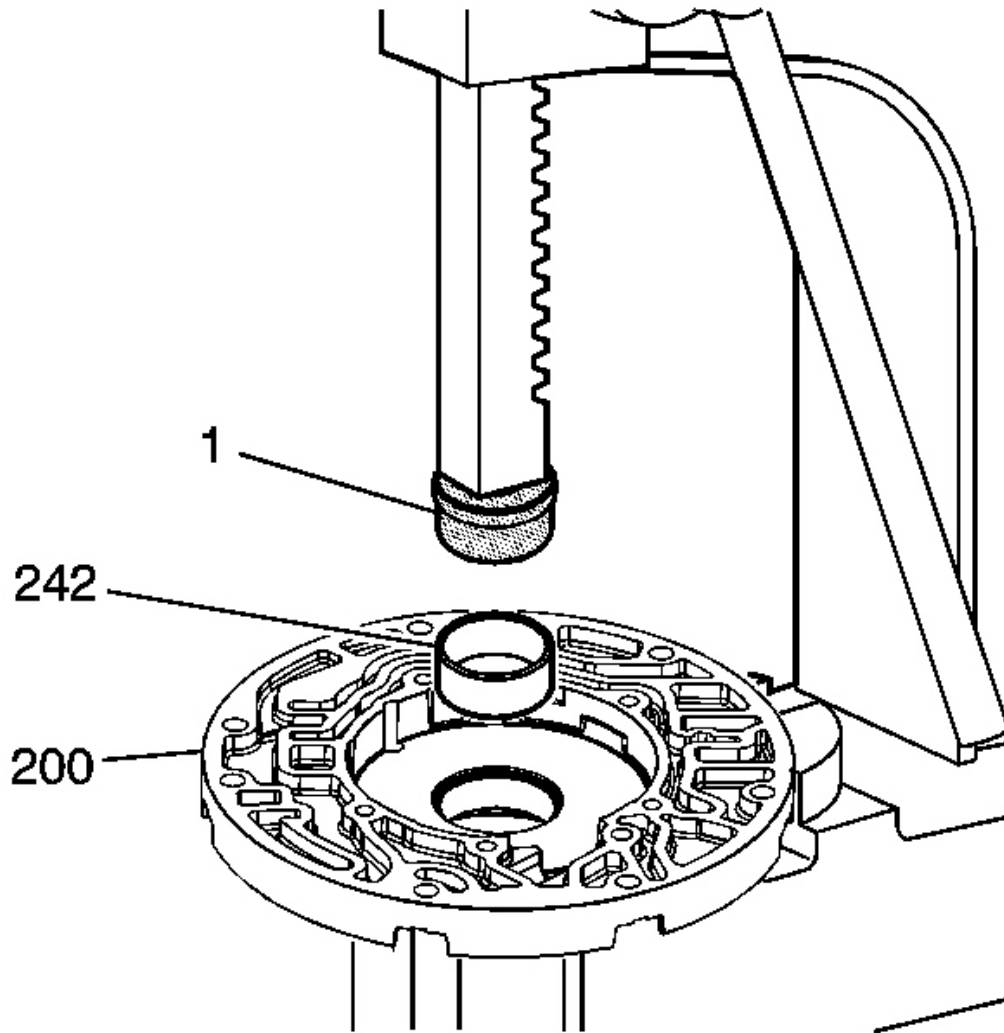

Fig. 378: Installing Pump Body Bushing
Courtesy of GENERAL MOTORS CORP.

5. Using **J 41778-1** (1) with an arbor press, install a new pump body bushing (242). See **Special Tools**.

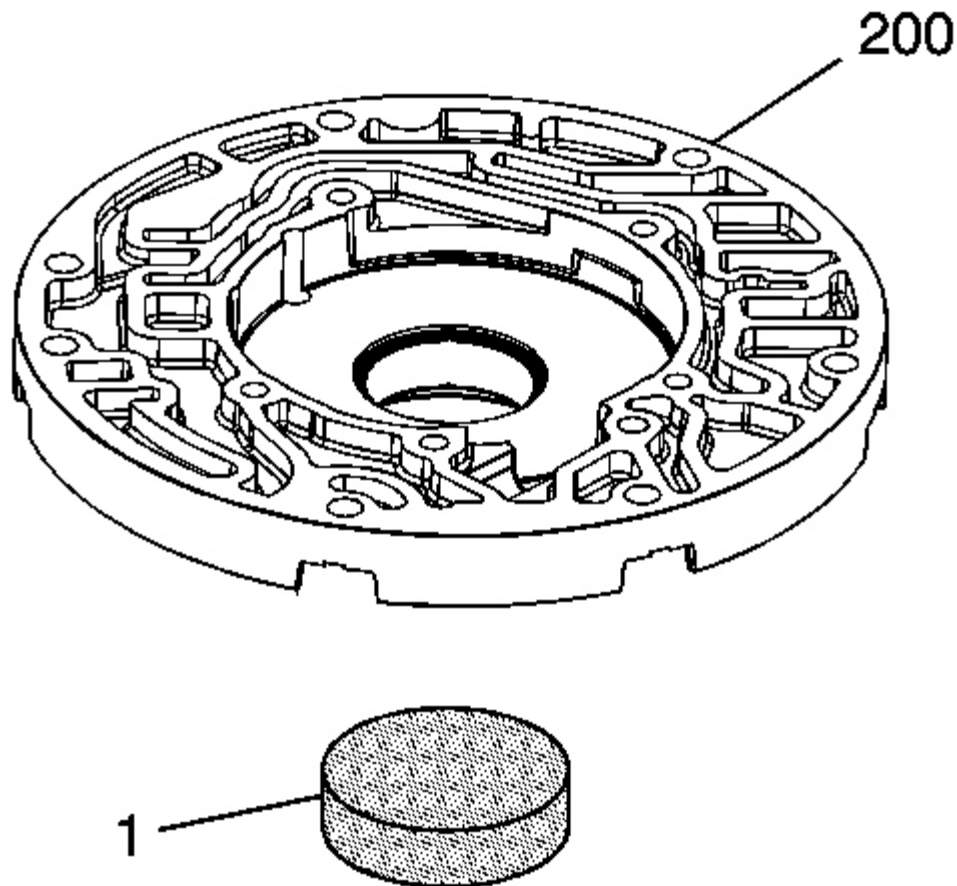

Fig. 379: Using J 41778-2
Courtesy of GENERAL MOTORS CORP.

6. Use the **J 41778-2** (1) to ensure proper bushing depth. See **Special Tools**.

OIL PUMP BODY ASSEMBLE

Assembly Procedure

- **J 25016** Pump Seal and Speedometer Gear Installer. See **Special Tools**.
- **J 36850** Transjel Lubricant

Assembly Procedure

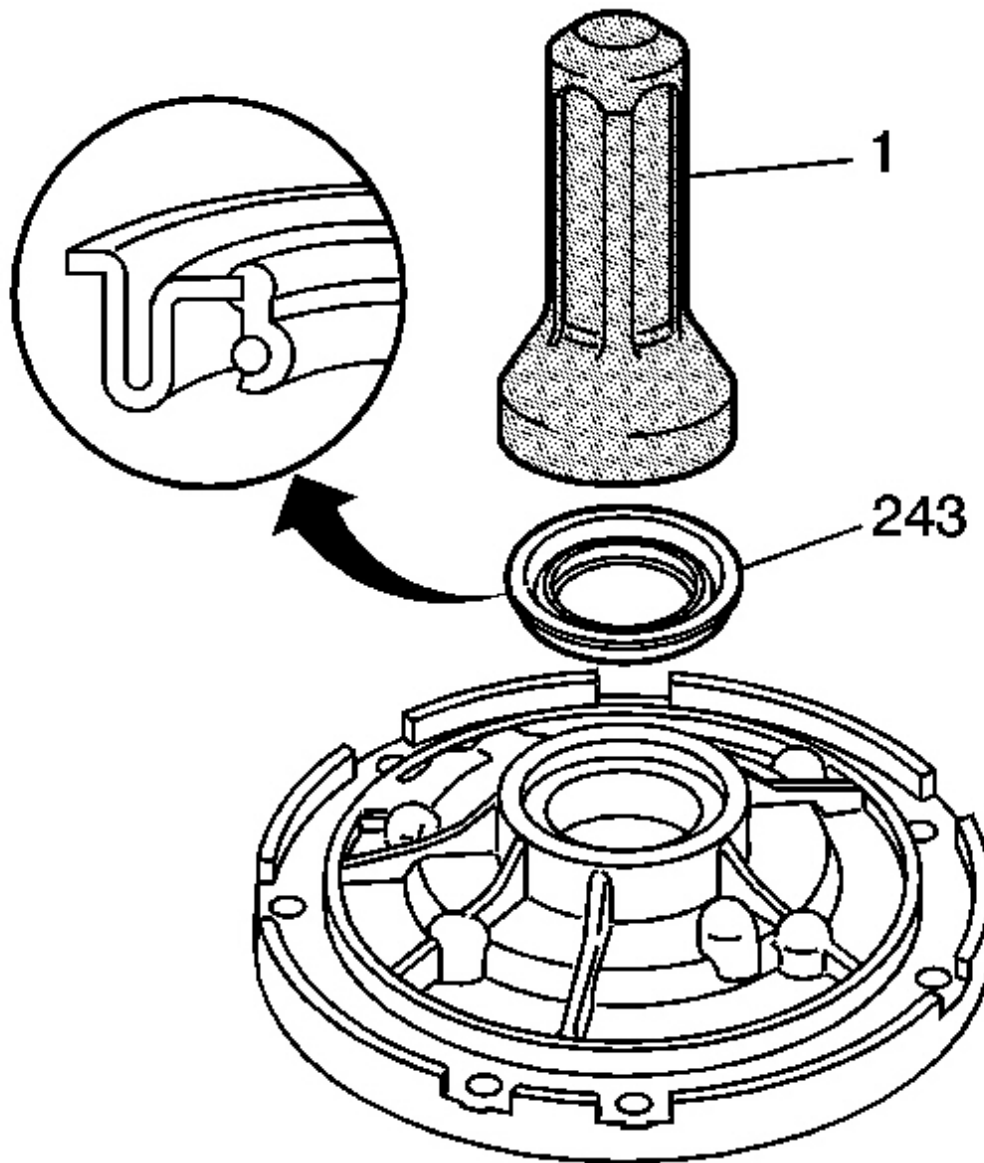

Fig. 380: Installing Oil Seal Assembly
Courtesy of GENERAL MOTORS CORP.

1. Using the **J 25016** (1), install the oil seal assembly (243). See **Special Tools**.

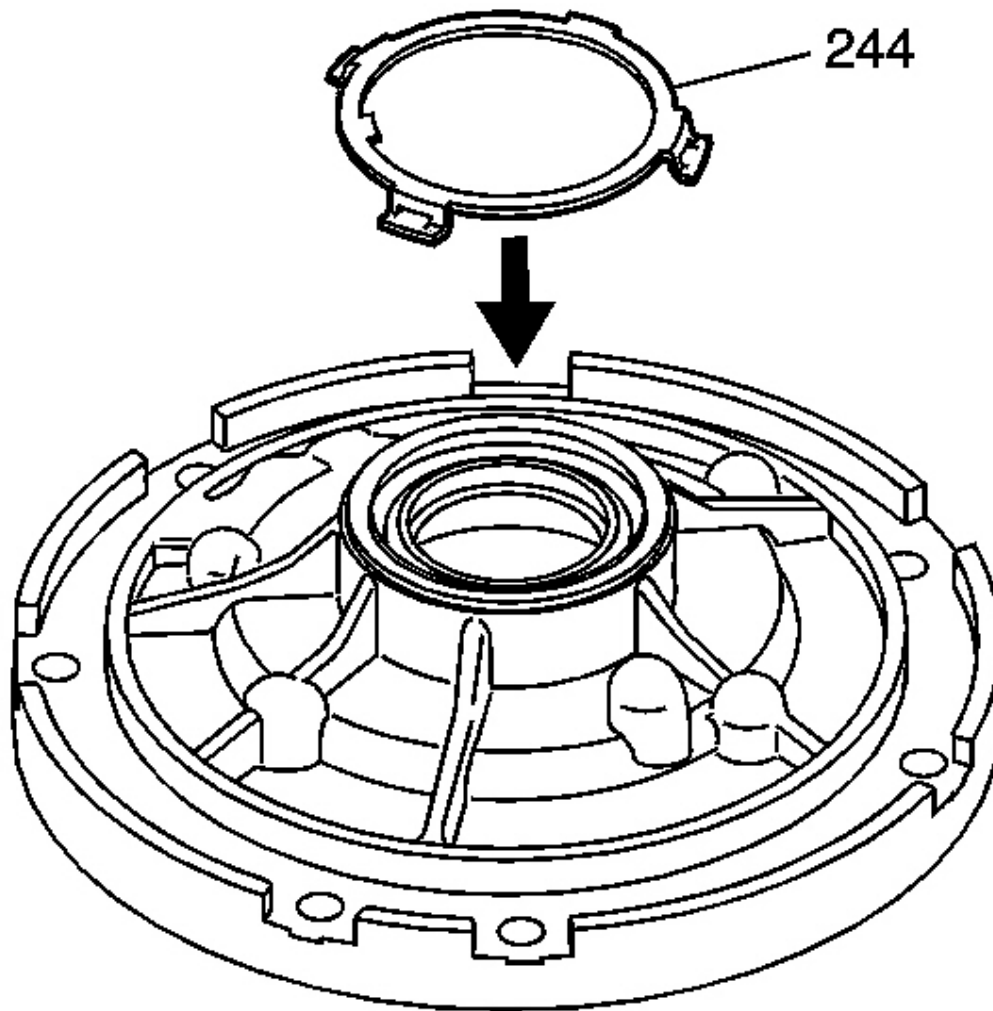

Fig. 381: View Of Fluid Seal Retainer
Courtesy of GENERAL MOTORS CORP.

2. Install the fluid seal retainer (244).

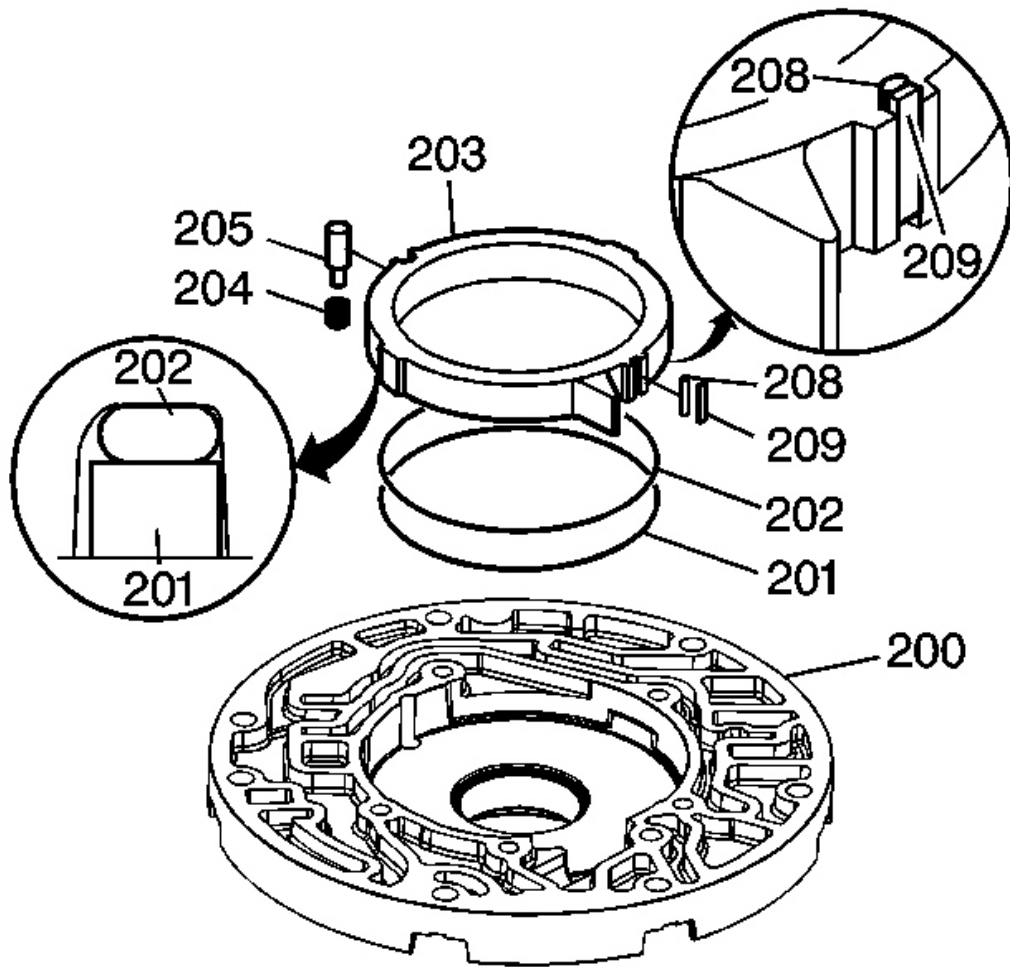

Fig. 382: Installing O-Ring Seal & Oil Seal Ring
 Courtesy of GENERAL MOTORS CORP.

3. Install an O-ring seal (202) and oil seal ring (201) into the groove on the back side of the pump slide (203).
4. Use **J 36850** or an equivalent, to retain the seal and the ring on the slide.
5. Install the pivot pin spring (204) into the pump body pocket.
6. Install the seal support (208) and the pump slide seal (209) into the pump slide (203). Retain with **J 36850** or equivalent.
7. Install the pump slide (203).

The oil seal ring must face downward into the pump pocket.

8. Install the pivot pin (205), index the slide notch with the pivot pin.

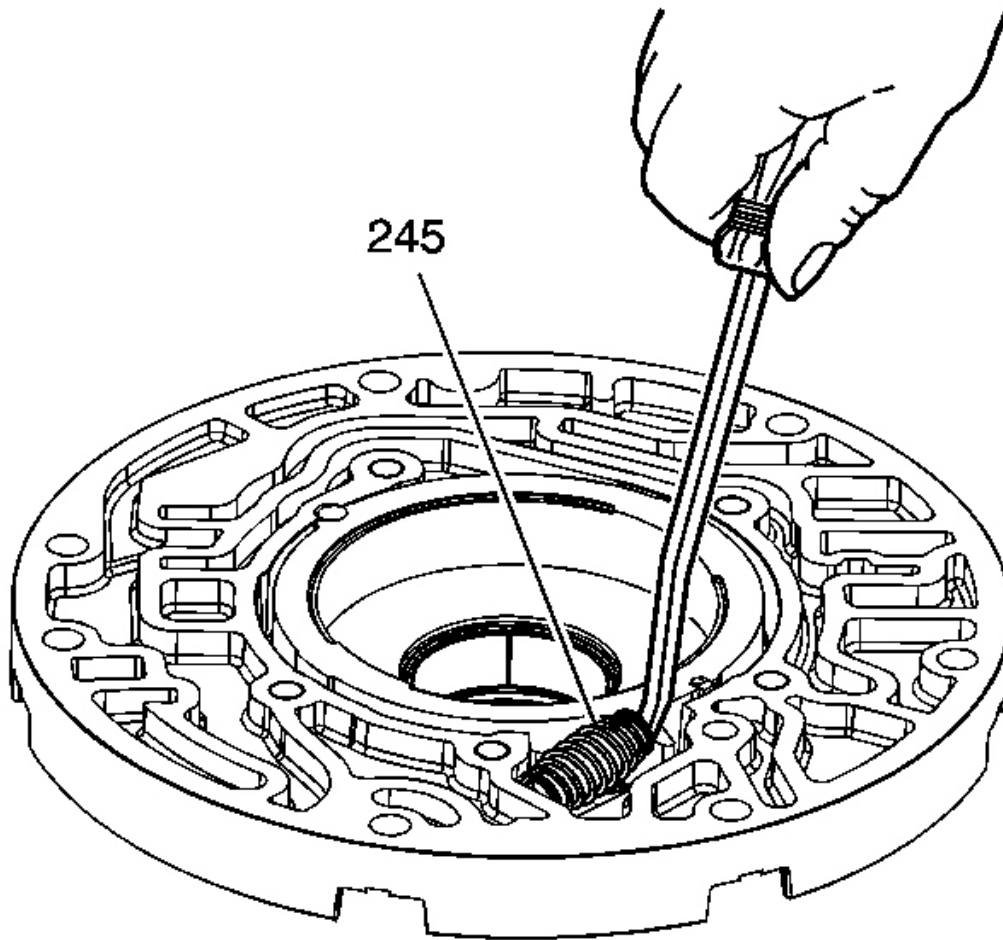

Fig. 383: Installing Fluid Pump Slide Outer Spring
Courtesy of GENERAL MOTORS CORP.

9. Install the fluid pump slide outer spring (245).

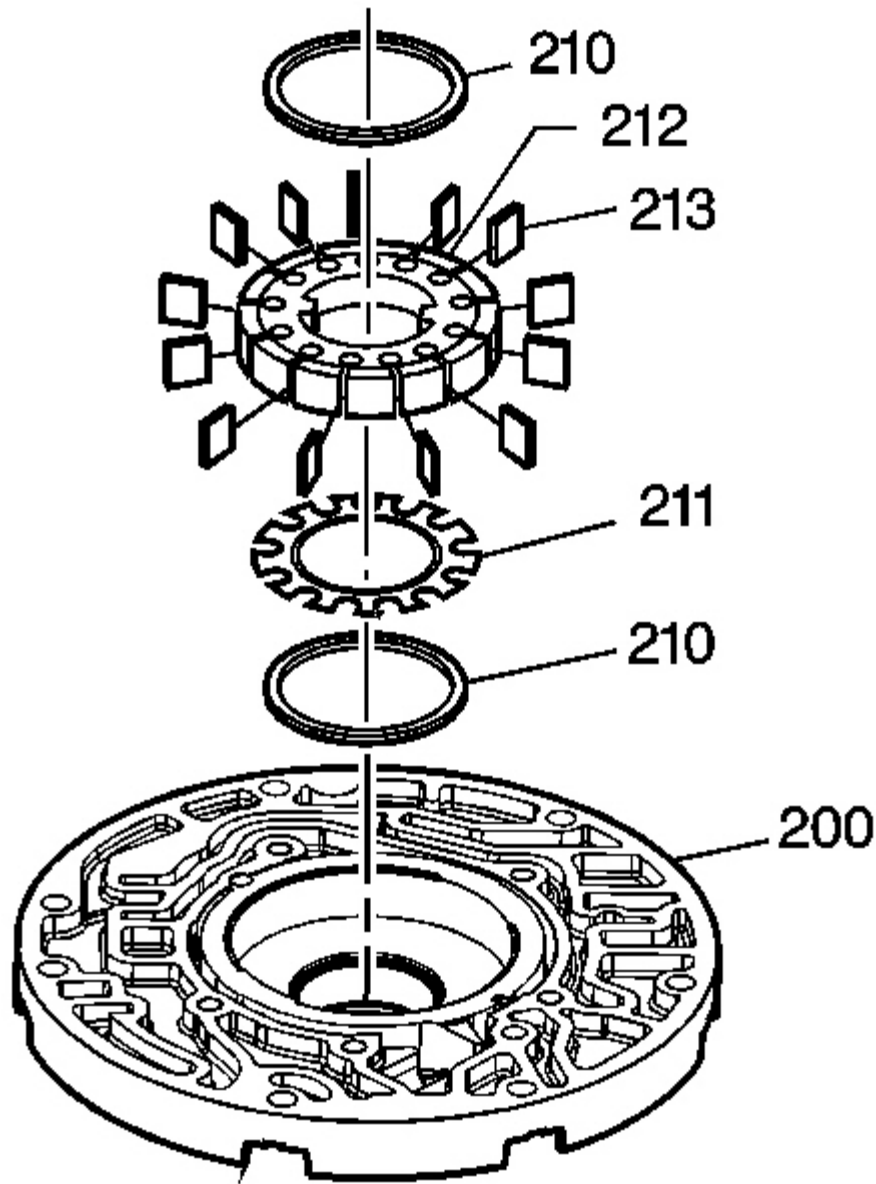

Fig. 384: Identifying Pump Vane Ring, Rotor Guide & Rotor
Courtesy of GENERAL MOTORS CORP.

10. Install the rotor guide (211) and the bottom pump vane ring (210) into the rotor (212) and retain with **J 36850** or an equivalent.

11. Install the rotor (212) with the rotor guide (211) toward the pump pocket.
12. Install the pump vanes (213). Ensure the vanes are flush with the oil pump body surface.
13. Install the top pump vane ring (210).

OIL PUMP COVER DISASSEMBLE

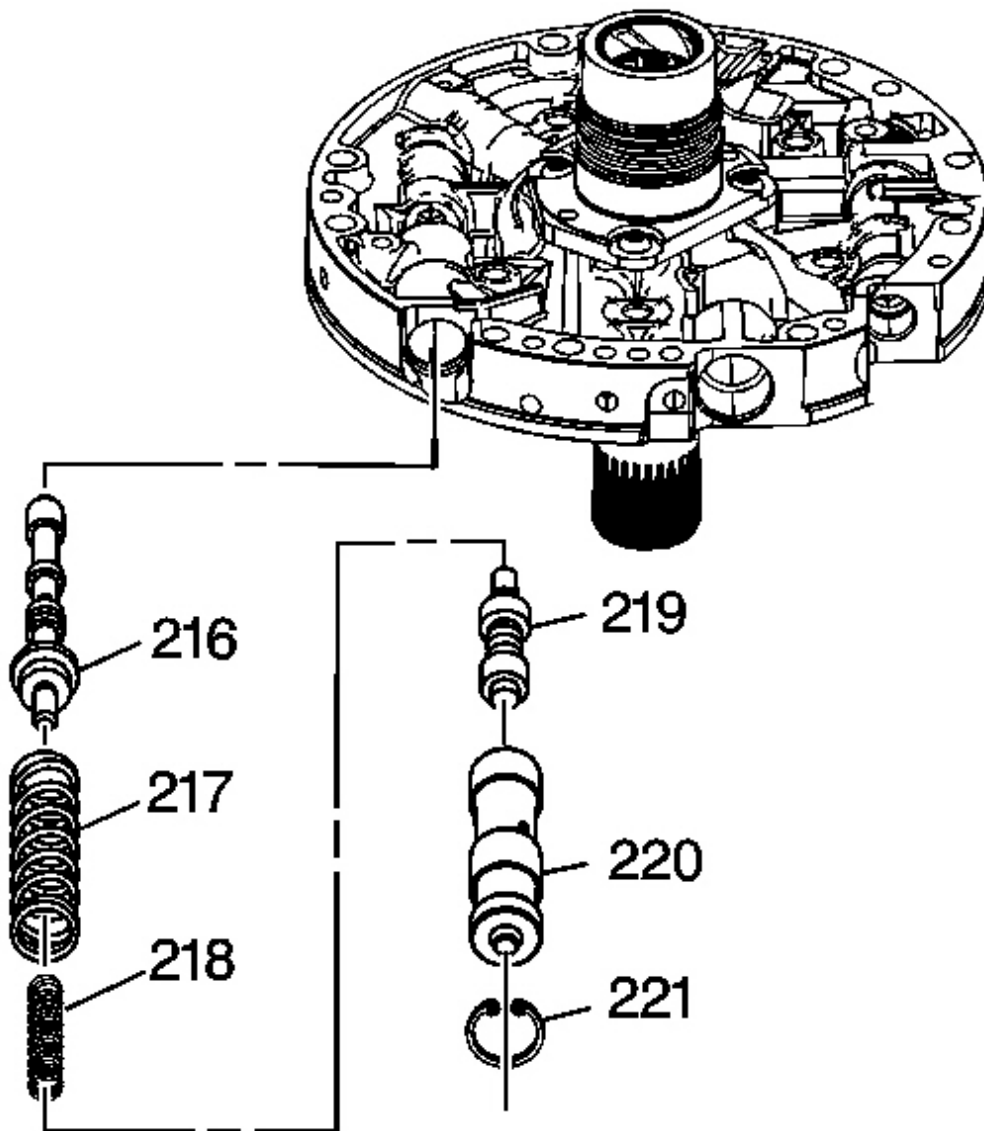

Fig. 385: View Of Oil Pump Cover & Components
Courtesy of GENERAL MOTORS CORP.

1. Remove the oil pump reverse boost valve retaining ring (221).
2. Remove the reverse boost valve sleeve (220) and the reverse boost valve (219).
3. Remove the pressure regulator isolator spring (218) and the pressure regulator valve spring (217).
4. Remove the pressure regulator valve (216).

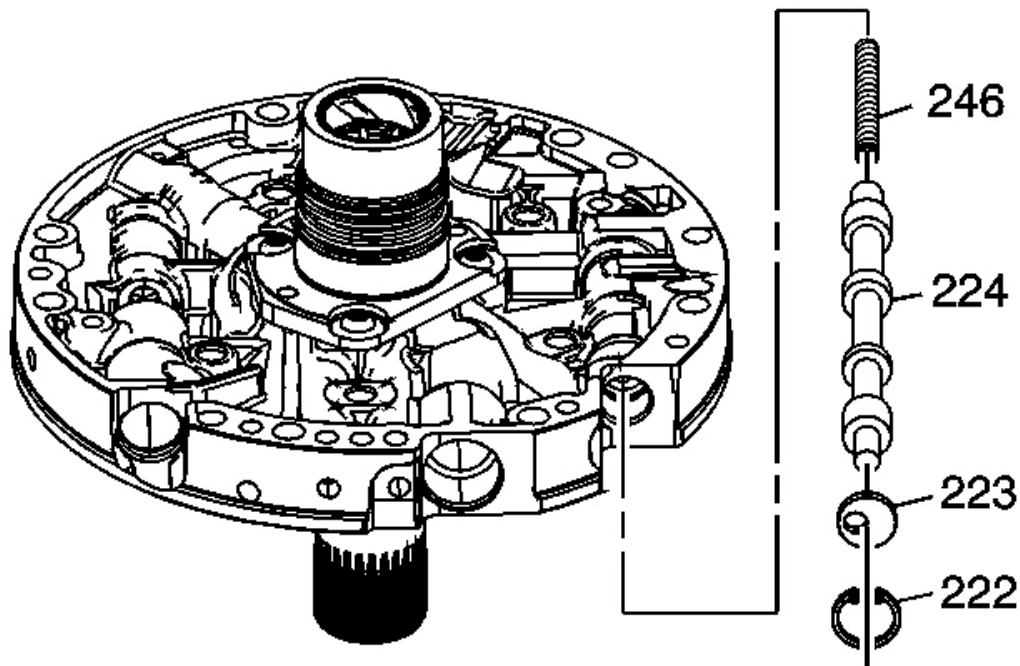

Fig. 386: Identifying Converter Clutch Valve Components
Courtesy of GENERAL MOTORS CORP.

5. Remove the oil pump converter clutch valve retaining ring (222).
6. Remove the stop valve (223) and the converter clutch valve (224).
7. Remove the converter clutch valve (246).

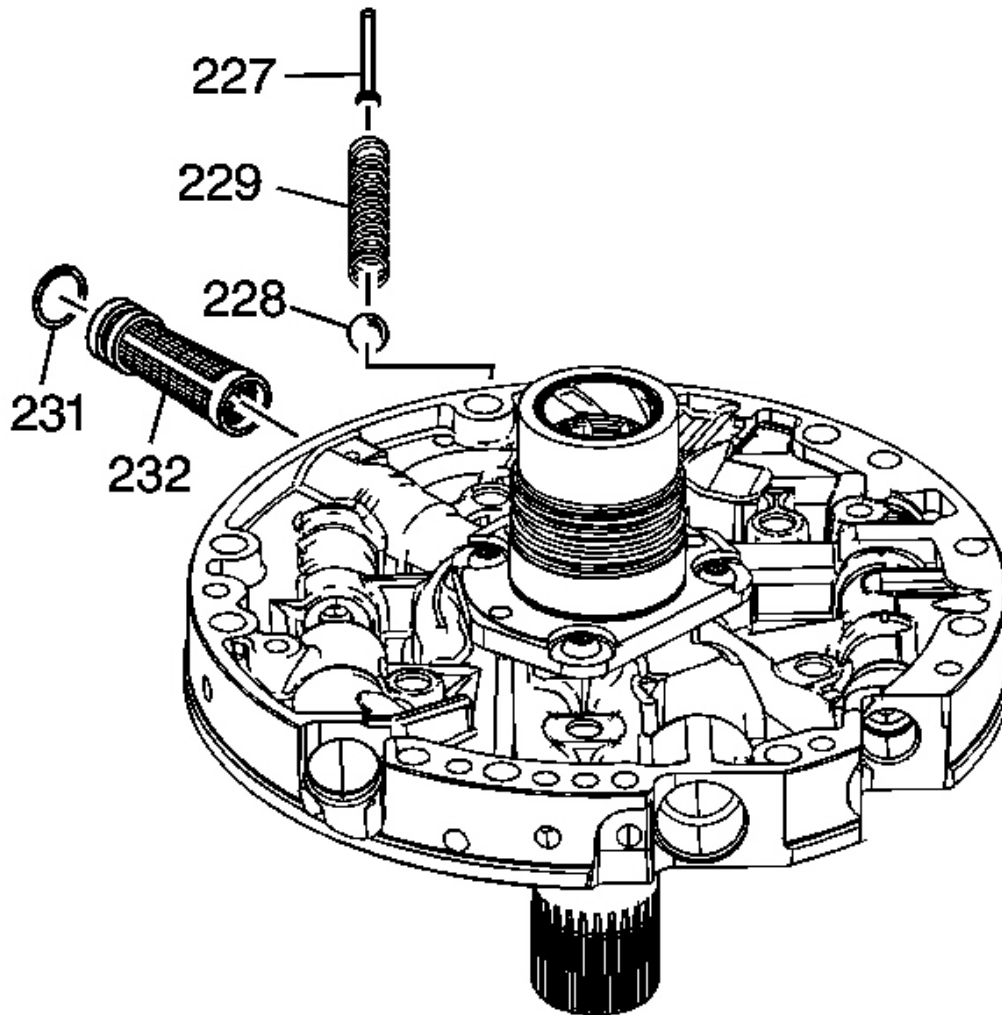

Fig. 387: Identifying Pressure Relief Bolt Valve components
Courtesy of GENERAL MOTORS CORP.

8. Remove the pressure relief bolt rivet (227).
9. Remove the pressure relief spring (229) and the pressure relief ball (228).
10. Remove the oil pump cover screen (232) and the oil pump cover screen seal (231).

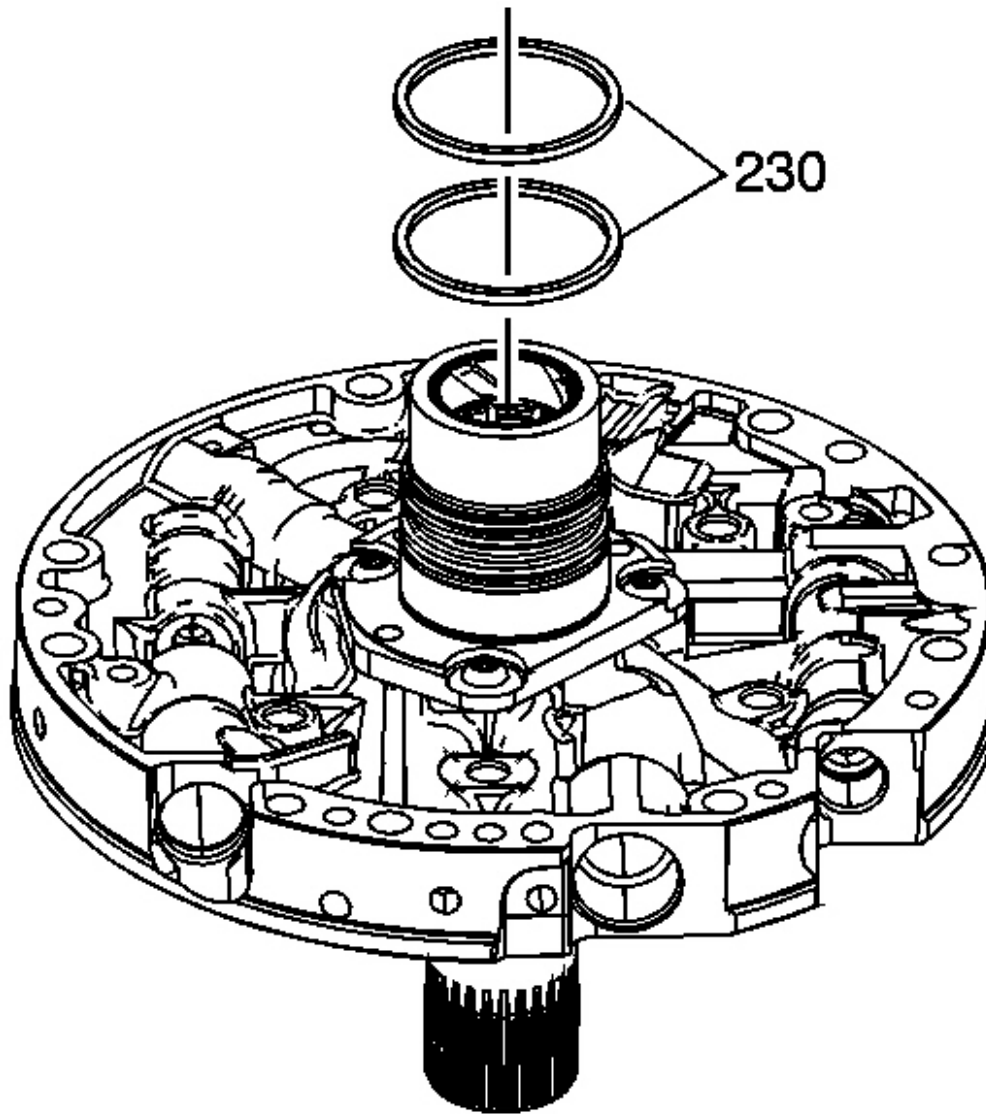

Fig. 388: View Of Stator Shaft Oil Seal Rings
Courtesy of GENERAL MOTORS CORP.

11. Remove the stator shaft oil seal rings (230).

OIL PUMP STATOR SHAFT BUSHING REPLACEMENT

Tools Required

- **J 7004-A** Universal Remover. See **Special Tools**.
- **J 8092** Universal Driver Handle - 3/4 in - 10
- **J 21465-01** Bushing Service Set. See **Special Tools**.
- **J 25019-14** Bushing Installer
- **J 34196-B** Transmission Bushing Service Set. See **Special Tools**.

Removal Procedure

Fig. 389: Locating Pump Cover, Check Valve Retainer, Ball Assemblies & Cup Plugs

Courtesy of GENERAL MOTORS CORP.

1. Inspect the pump cover, all check valve retainer and ball assemblies (237), cup plugs (235, 236) and orificed cup plugs (238, 240).

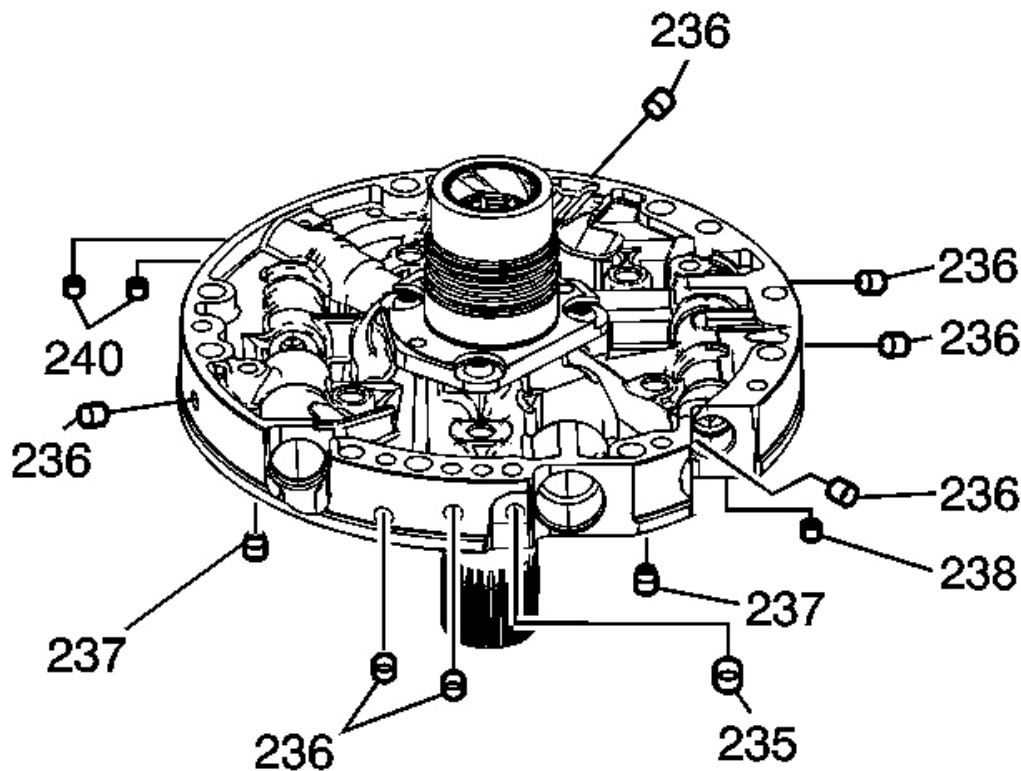
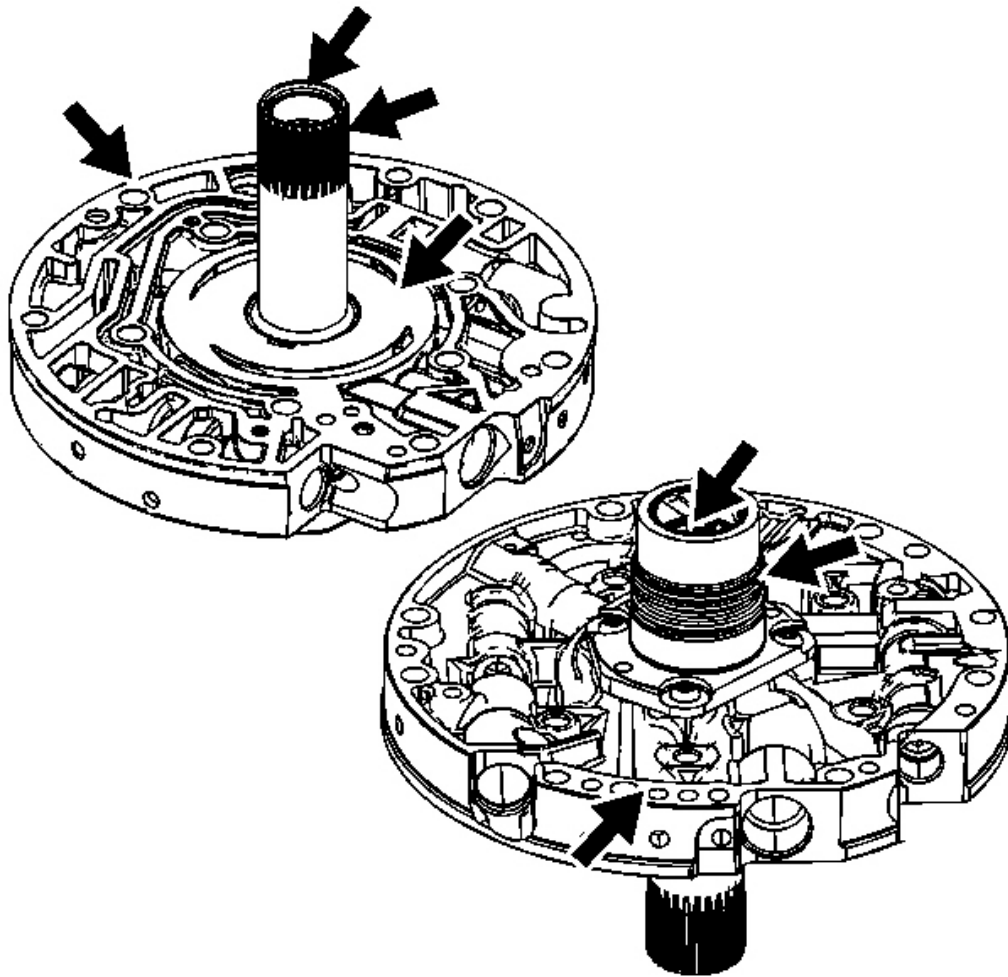

Fig. 390: View Of Pump Cover
Courtesy of GENERAL MOTORS CORP.

2. Inspect the pump cover for the following conditions:
 - Worn or damaged bushings
 - Foreign material or debris
 - Porosity
 - Scored or irregular mating faces
 - Cross channel leaks

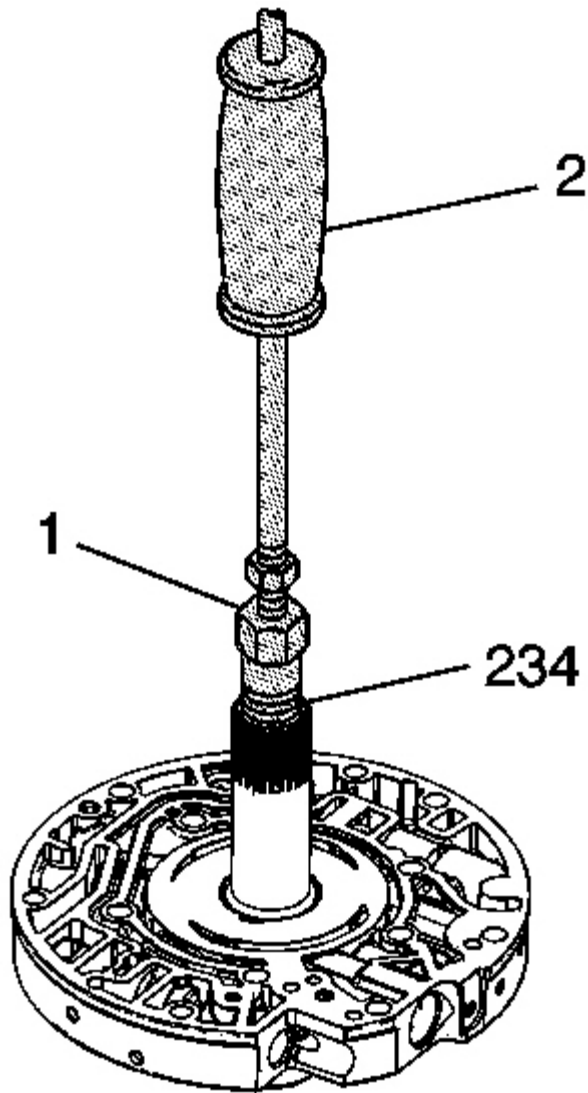

Fig. 391: Removing Stator Shaft Front Bushing
Courtesy of GENERAL MOTORS CORP.

3. Using the **J 21465-15** (1) with the **J 7004-A** (2), remove the stator shaft front bushing (234). See **Special Tools**.

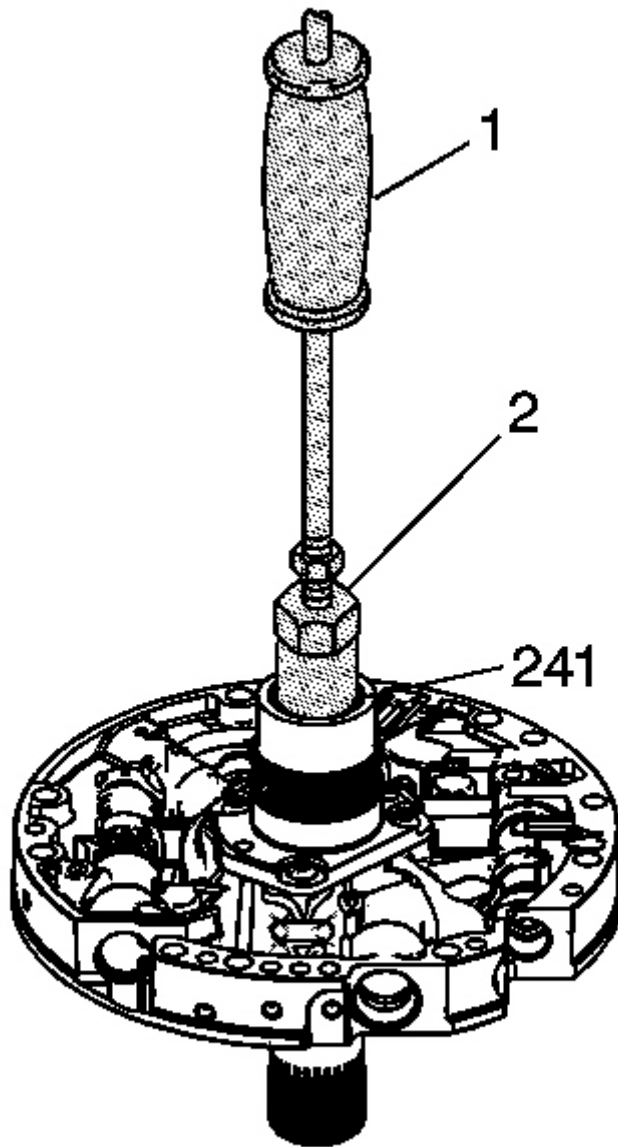

Fig. 392: Removing Stator Shaft Rear Bushing
Courtesy of GENERAL MOTORS CORP.

4. Using the **J 25019-14** (2) with the **J 7004-A** (1), remove the stator shaft rear bushing (241). See Special Tools.

Installation Procedure

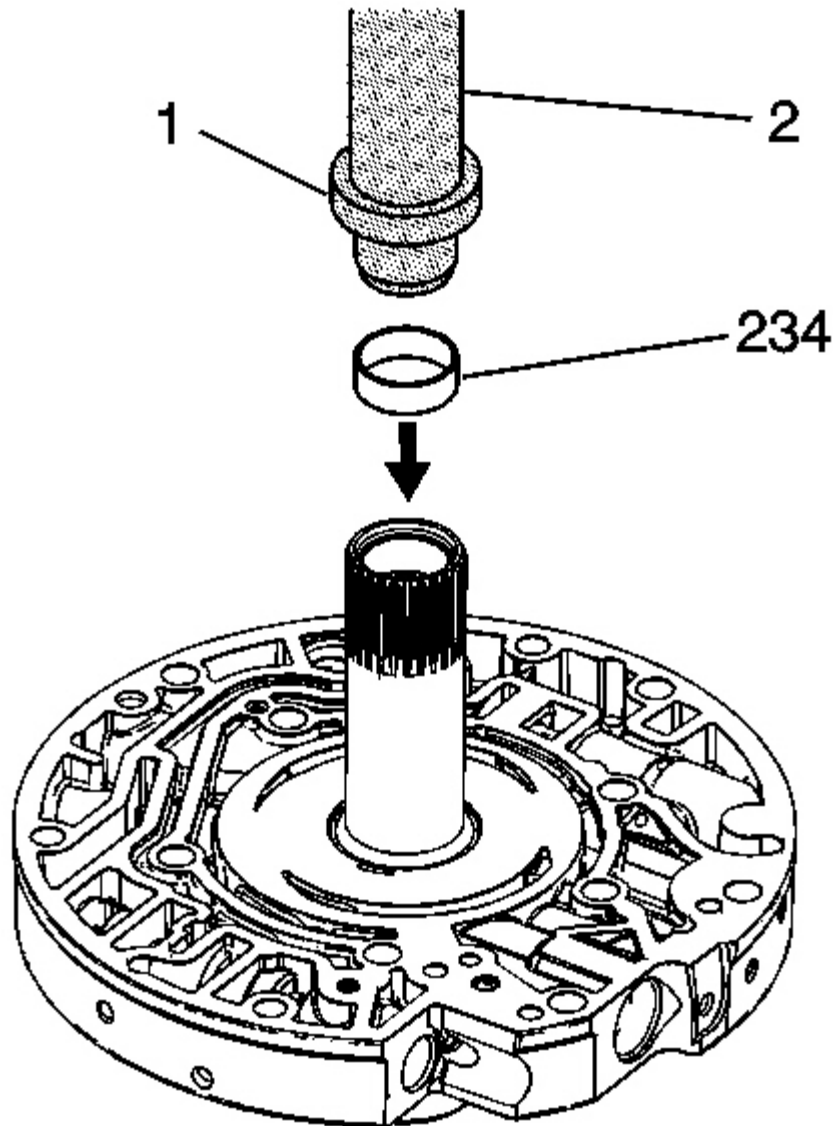

Fig. 393: Installing Stator Shaft Front Bushing
Courtesy of GENERAL MOTORS CORP.

1. Using the J 21465-2 (1) and the J 8092 (2), install a new stator shaft front bushing (234). See **Special Tools**.

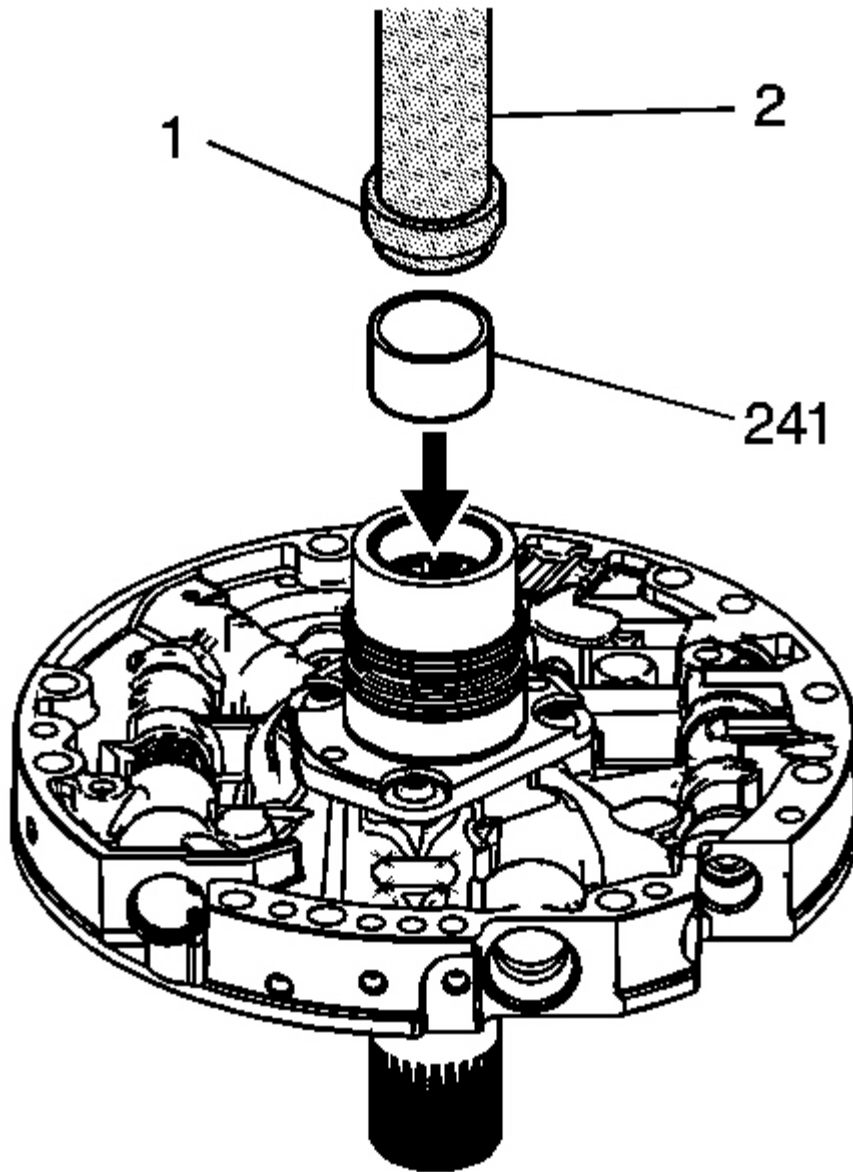

Fig. 394: Installing Stator Shaft Rear Bushing
Courtesy of GENERAL MOTORS CORP.

2. Using the J 34196-2 (1) which is part of kit J 34196-B and the J 8092 (2), install the stator shaft rear bushing (241). See **Special Tools**.

OIL PUMP COVER ASSEMBLE

Tools Required

- **J 38735-3** Pusher. See Special Tools.
- **J 39855** Stator Shaft Seal Installer. See Special Tools.

Assembly Procedure

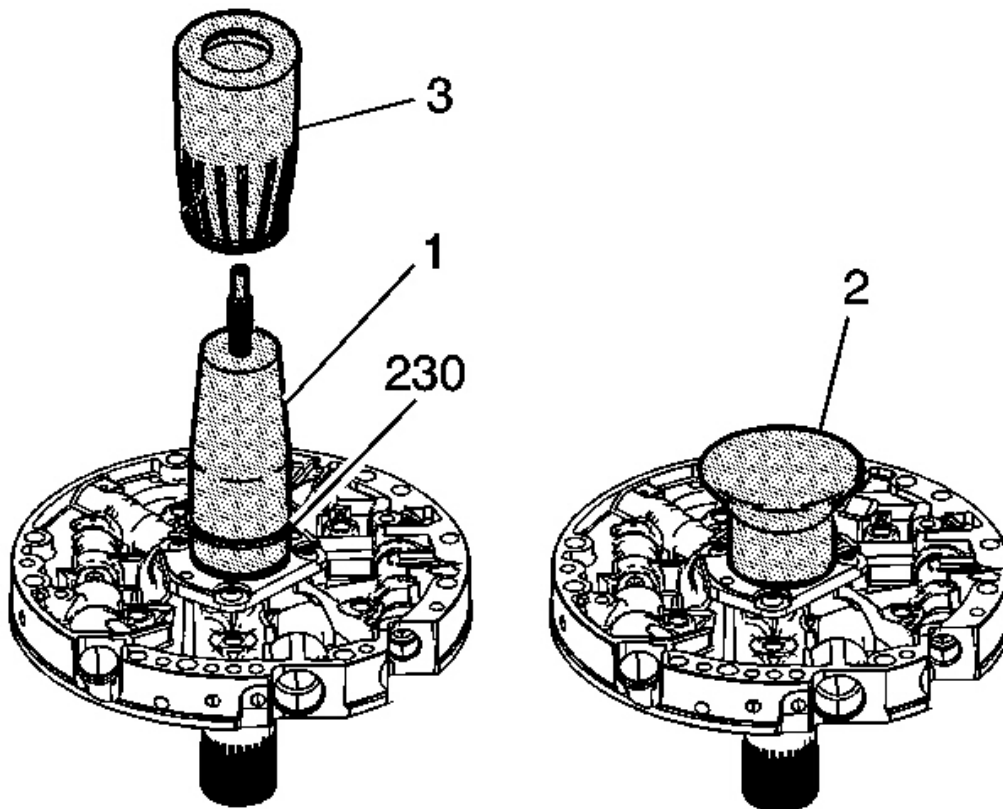

Fig. 395: Installing Stator Shaft Oil Seal Rings
Courtesy of GENERAL MOTORS CORP.

1. Using the J 39855-1 (1) which is part of kit **J 39855** and the **J 38735-3** (3), install the stator shaft oil seal rings (230). See Special Tools.
2. Place J 39855-2 (2) which is part of kit **J 39855** over the seals. See Special Tools.

3. Leave J 39855-2 (2) which is part of kit **J 39855** on the stator shaft until just before the pump is to be installed into the transmission. See **Special Tools**.

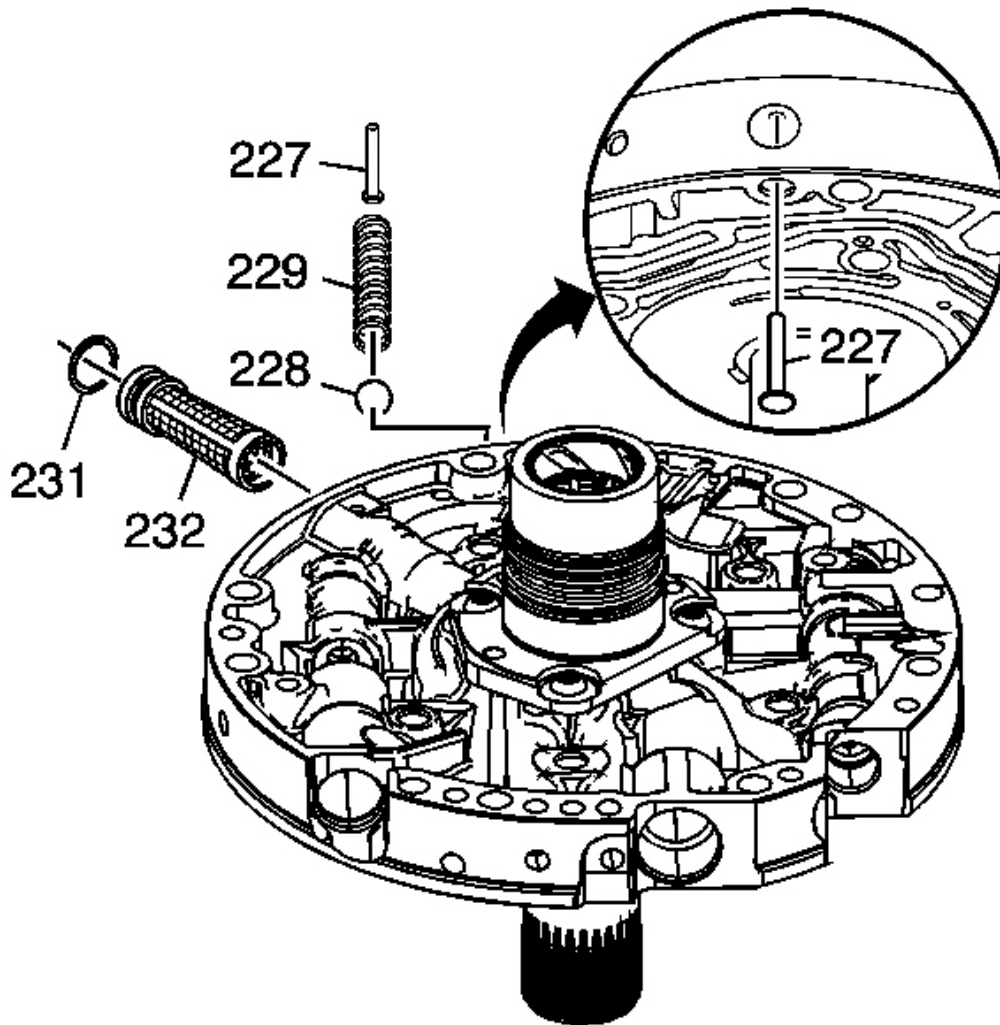

Fig. 396: Identifying Pressure Relief Bolt Valve components
Courtesy of GENERAL MOTORS CORP.

4. Install the pressure relief ball (228) and pressure relief spring (229).
5. Install the pressure relief bolt rivet (227).
6. Install the oil pump cover screen seal (231) on the oil pump cover screen (232).

7. Install the oil pump cover screen (232) into the pump cover.

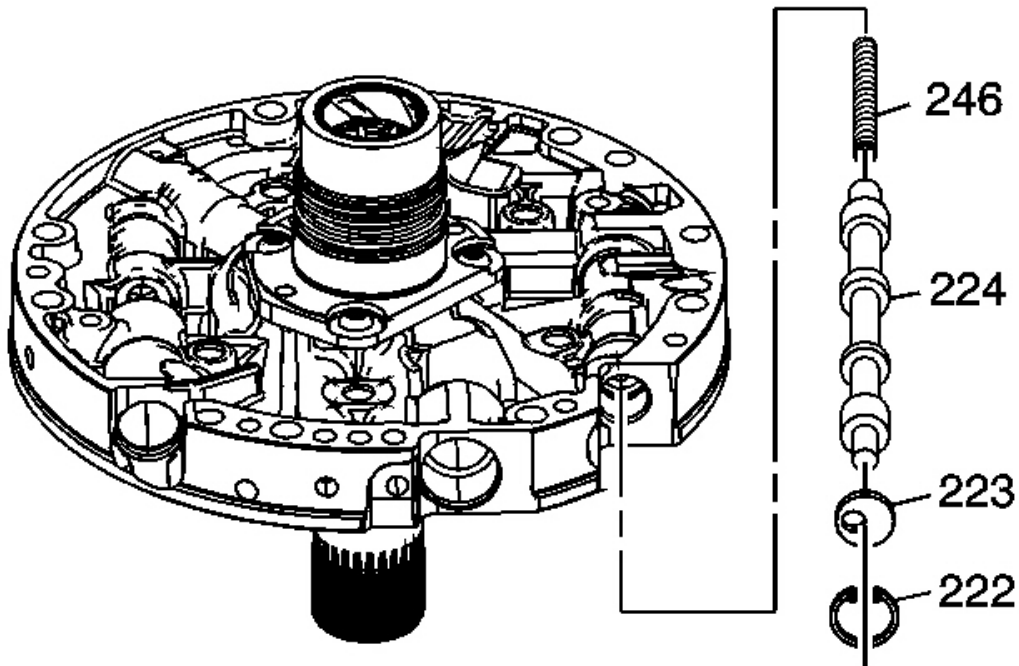

Fig. 397: Identifying Converter Clutch Valve
Courtesy of GENERAL MOTORS CORP.

8. Install the converter clutch valve spring (246).
9. Install the converter clutch valve (224).
10. Install the stop valve (223) and the oil pump converter clutch valve retaining ring (222).

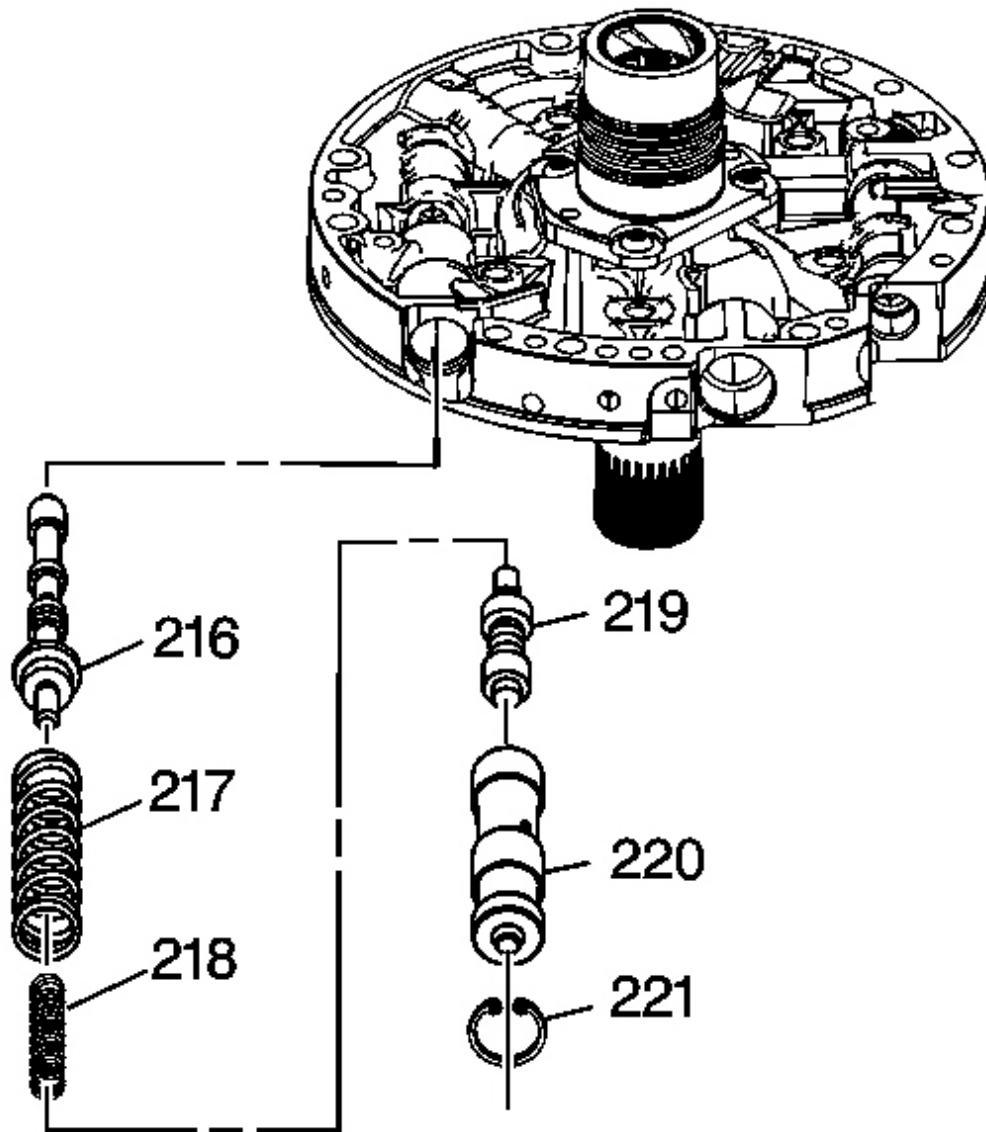

Fig. 398: View Of Oil Pump Cover & Components
 Courtesy of GENERAL MOTORS CORP.

11. Install the pressure regulator valve (216).
12. Install the pressure regulator isolator spring (218) and the pressure regulator valve spring (217).

2007 Hummer H3

2007 TRANSMISSION Automatic Transmission - 4L60-E/4L65-E/4L70-E - H3

13. Install the reverse boost valve (219) in the reverse boost valve sleeve (220).
14. Install the reverse boost valve and sleeve in the pump cover.
15. Install the oil pump reverse boost valve retaining ring (221).

OIL PUMP COVER AND BODY ASSEMBLE

Tools Required

J 21368 Pump Body and Cover Alignment Band. See **Special Tools**.

Assembly Procedure

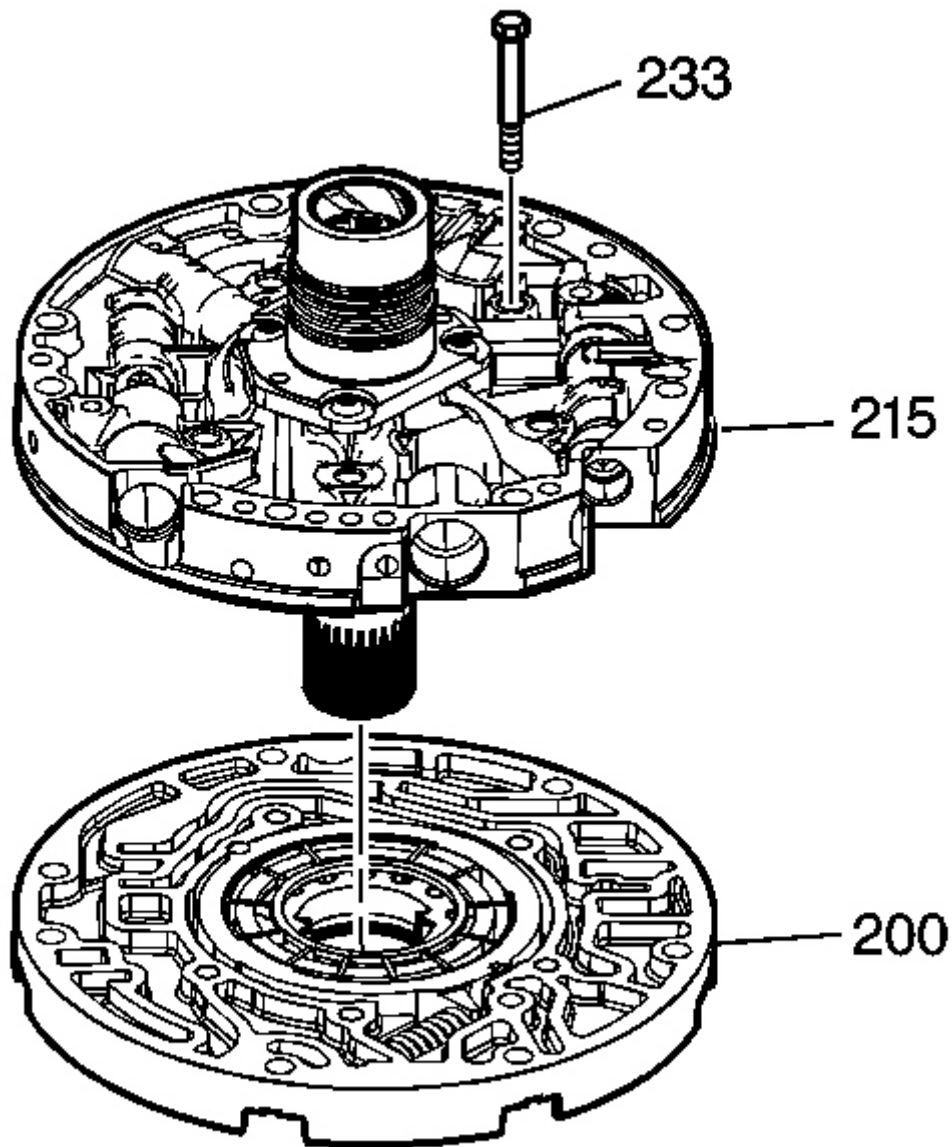

Fig. 399: View Of Oil Pump Cover & Oil Pump Body
Courtesy of GENERAL MOTORS CORP.

1. Place the oil pump cover onto the oil pump body and put stator shaft through a hole in the bench.
2. Install the pump cover bolts (233) finger tight only.

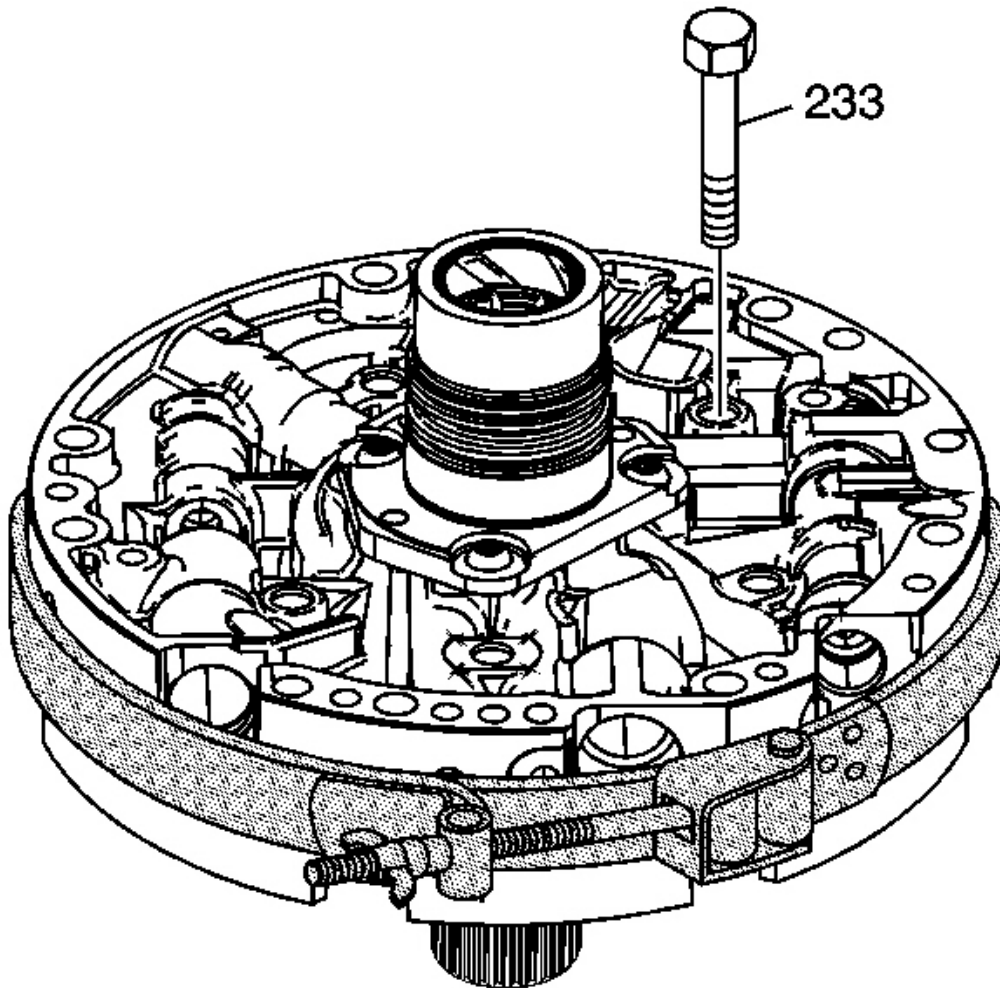

Fig. 400: Identifying Pump Cover Bolts
Courtesy of GENERAL MOTORS CORP.

3. Install the **J 21368** . See **Special Tools**.

NOTE: Refer to **FASTENER NOTICE** .

4. Tighten the pump cover bolts (233).

Tighten: Tighten the bolts to 24 N.m (18 lb ft).

5. Remove the **J 21368** . See Special Tools.

OIL PUMP ASSEMBLY INSTALLATION

Tools Required

- **J 25025-1** Dial Indicator Mounting Post
- **J 39855** Stator Shaft Seal Installer. See Special Tools.

Installation Procedure

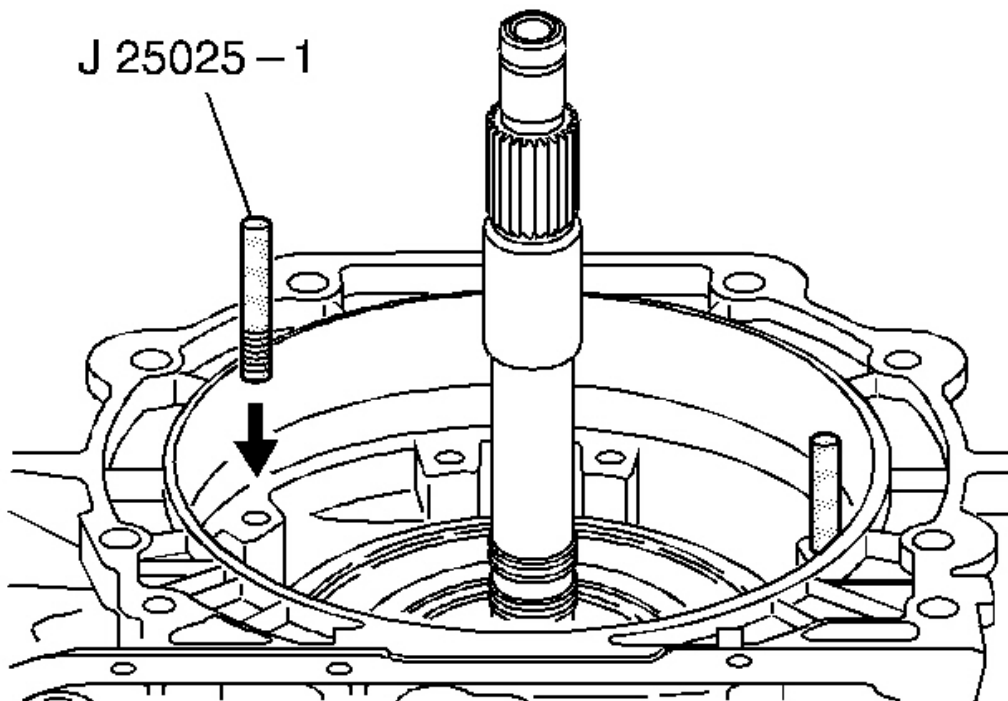

Fig. 401: Installing J 25025-1
Courtesy of GENERAL MOTORS CORP.

1. Install the **J 25025-1** .

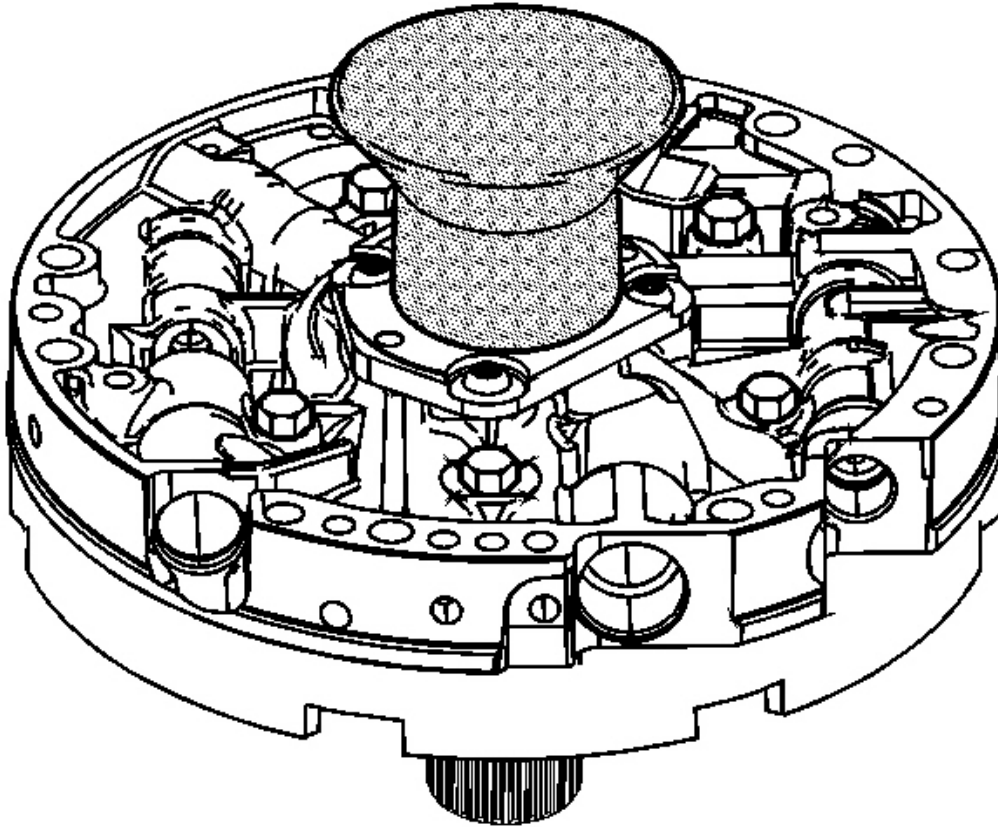

Fig. 402: View Of 39855-2
Courtesy of GENERAL MOTORS CORP.

2. Remove the J 39855-2 which is part of kit J 39855 . See **Special Tools**.

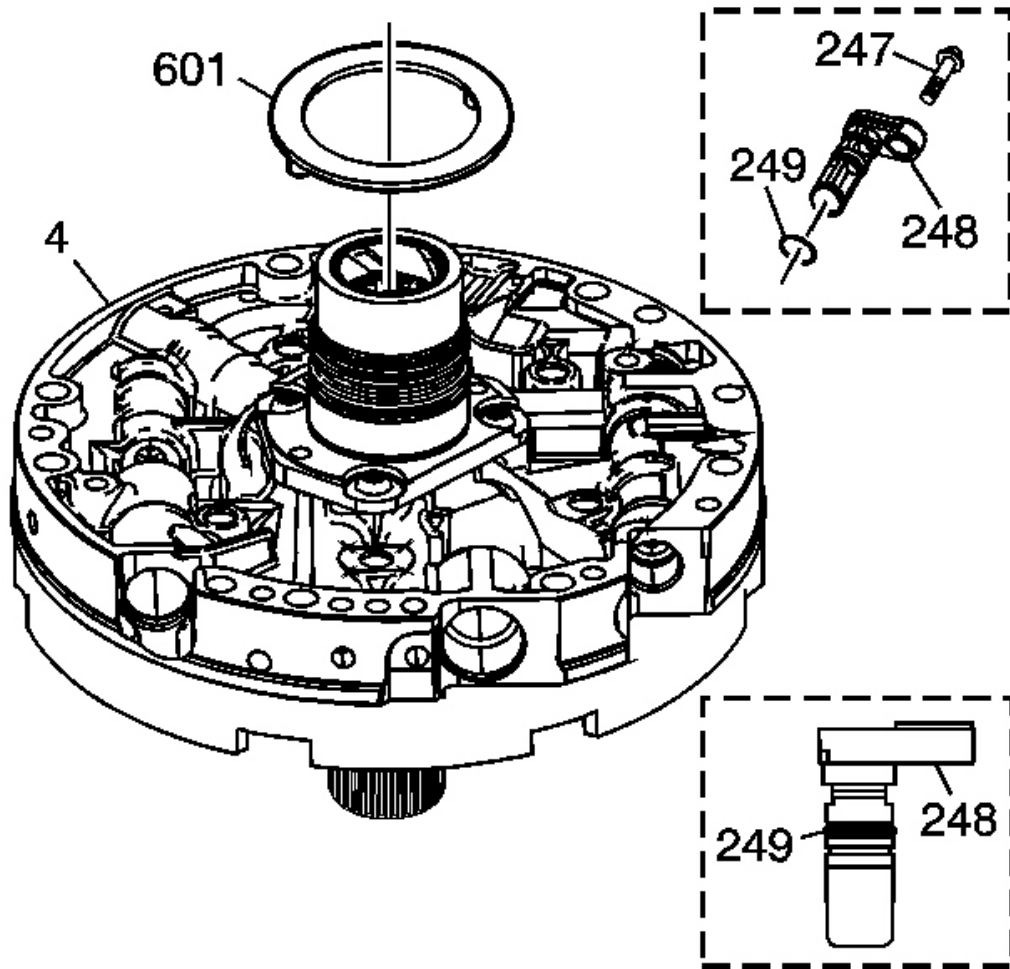

Fig. 403: Identifying Drum Thrust Washer
 Courtesy of GENERAL MOTORS CORP.

3. Install the pump to drum thrust washer (601).
4. Use **J 36850** or equivalent to retain the washer to the pump.
5. For pump assemblies with an ISS hole plug (248), lubricate a NEW O-ring (249) with transmission fluid and install onto the ISS hole plug (248).
6. Install the ISS hole plug (248) into the ISS hole and align with the mounting hole.

NOTE: Refer to **FASTENER NOTICE** .

7. Install the bolt (247).

Tighten: Tighten the bolt to 9-11 N.m (6.6-8.1 lb ft).

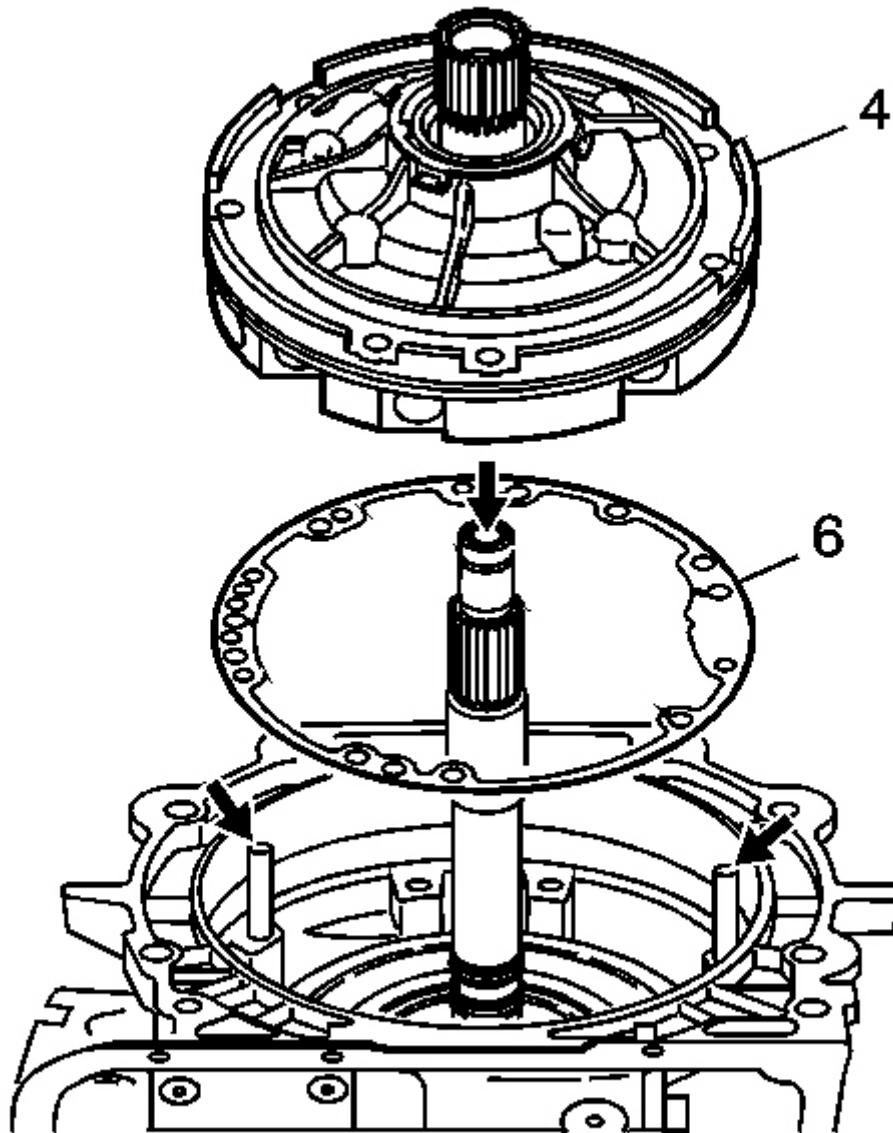

Fig. 404: View Of Pump Cover, Case & Gasket
Courtesy of GENERAL MOTORS CORP.

8. Install the pump cover to case gasket (6).

IMPORTANT: The oil pump to case seal is installed after the oil pump assembly, during torque converter installation. Refer to Converter Housing Installation.

9. Install the oil pump assembly (4) into the case and align all holes properly.

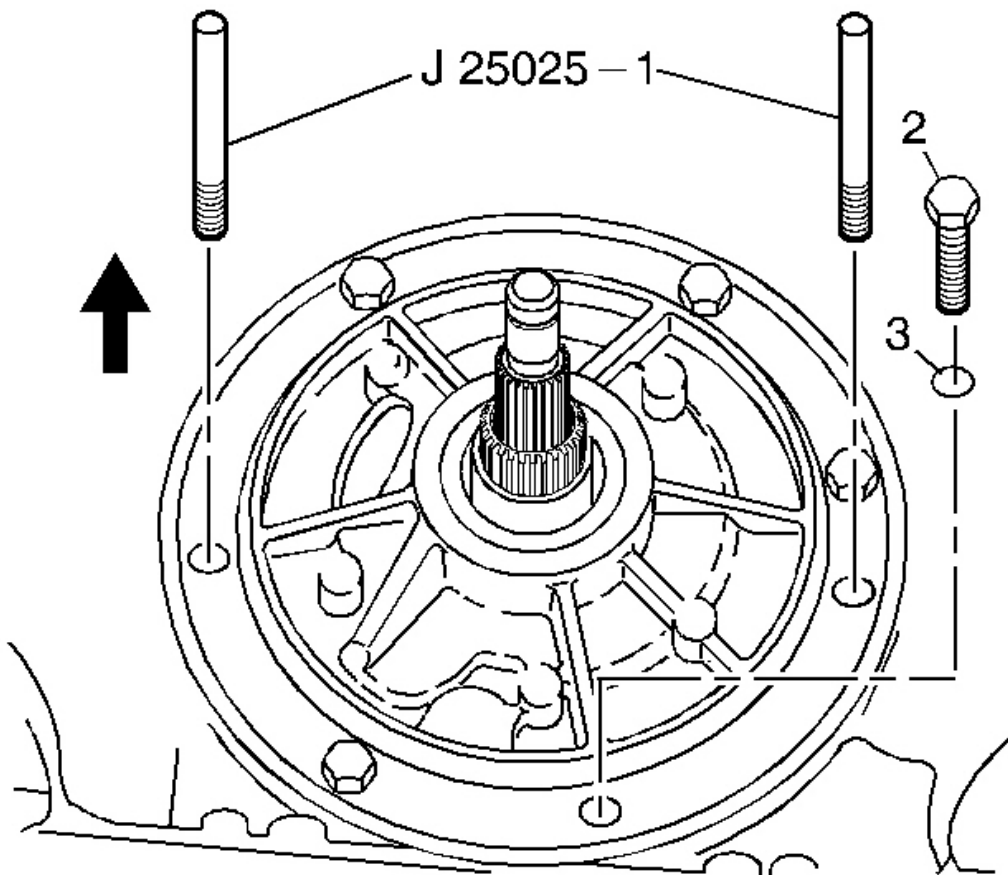

Fig. 405: View Of J 25025-1
Courtesy of GENERAL MOTORS CORP.

IMPORTANT: The pump to case bolt O-ring seals (3) must be replaced.

10. Install the pump to case bolts (2) with new O-ring seals (3).

Tighten: Tighten the bolts to 29 N.m (21 lb ft).

11. Remove the **J 25025-1** .

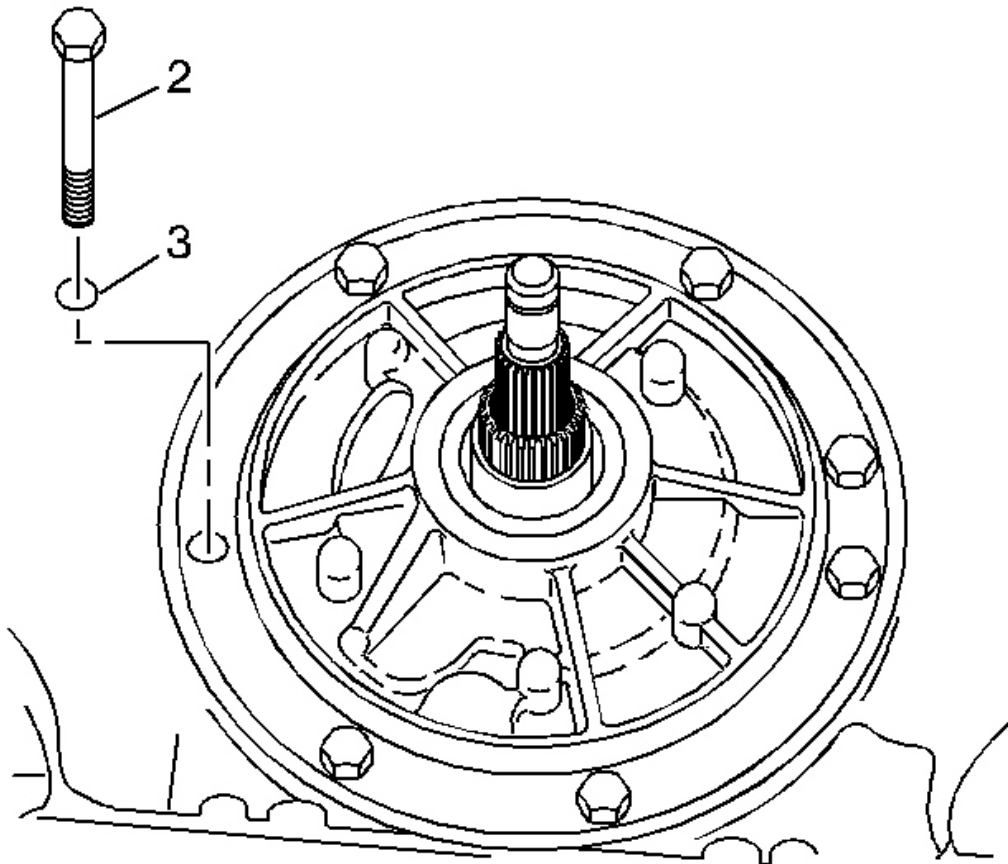

Fig. 406: Locating Pump To Case Bolts & O-Ring Seals
Courtesy of GENERAL MOTORS CORP.

12. Install the remaining pump to case bolts (2) and O-ring seals (3), in the holes where the **J 25025-1** were.

Tighten: Tighten the bolts to 29 N.m (21 lb ft).

2007 Hummer H3

2007 TRANSMISSION Automatic Transmission - 4L60-E/4L65-E/4L70-E - H3

TRANSMISSION END PLAY CHECK

Tools Required

- **J 25022** End Play Fixture Adapter. See **Special Tools**.
- **J 34725** End Play Checking Adapter. See **Special Tools**.
- **J 43205** End Play Fixture Adapter (300 mm). See **Special Tools**.
- **J 24773-A** Oil Pump Remover. See **Special Tools**.
- **J 8001** Dial Indicator Set
- **J 25025-7A** Dial Indicator Post. See **Special Tools**.

Check Procedure

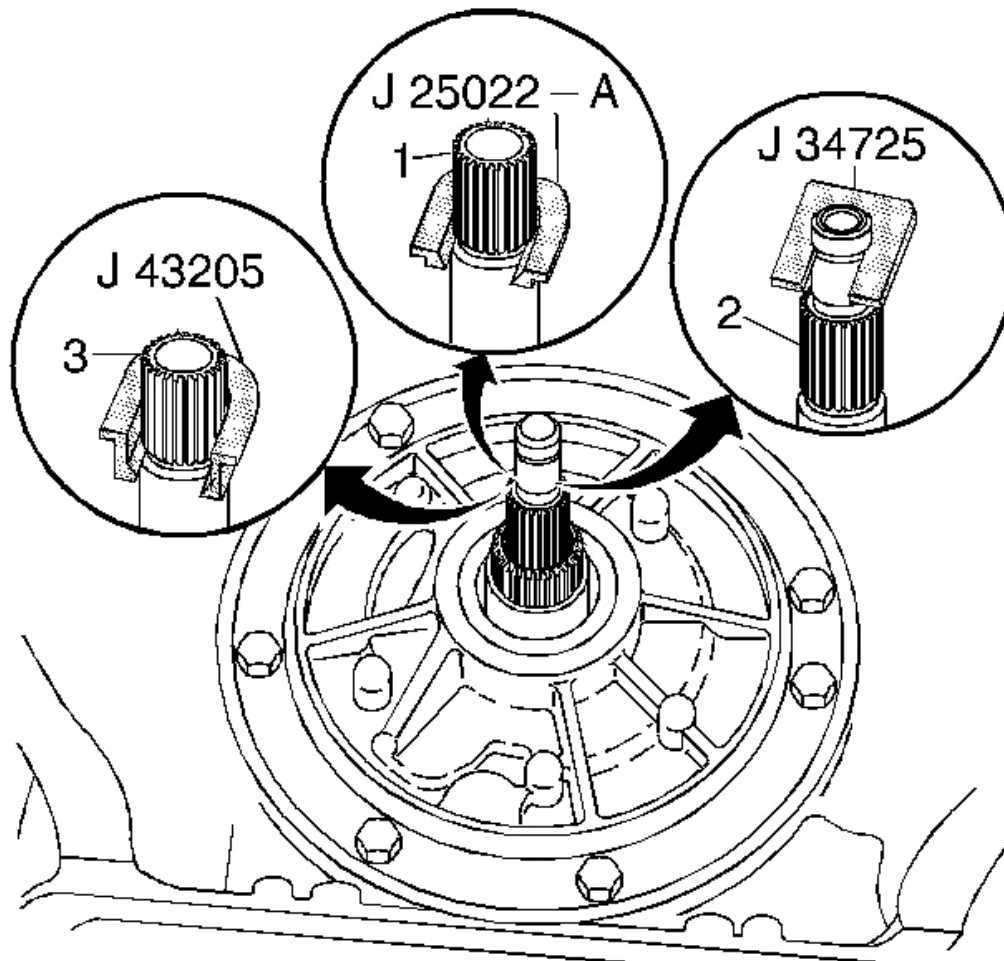

Fig. 407: Identifying Different End Play Fixture Adapters
Courtesy of GENERAL MOTORS CORP.

IMPORTANT: Torque converter size is model dependent.

1. Install an end play fixture adapter.
 - Use **J 25022** for a 245 mm and 258 mm turbine shaft (1). See **Special Tools**.
 - Use **J 34725** for a 298 mm turbine shaft (2). See **Special Tools**.
 - Use **J 43205** for a 300 mm turbine shaft (3). See **Special Tools**.

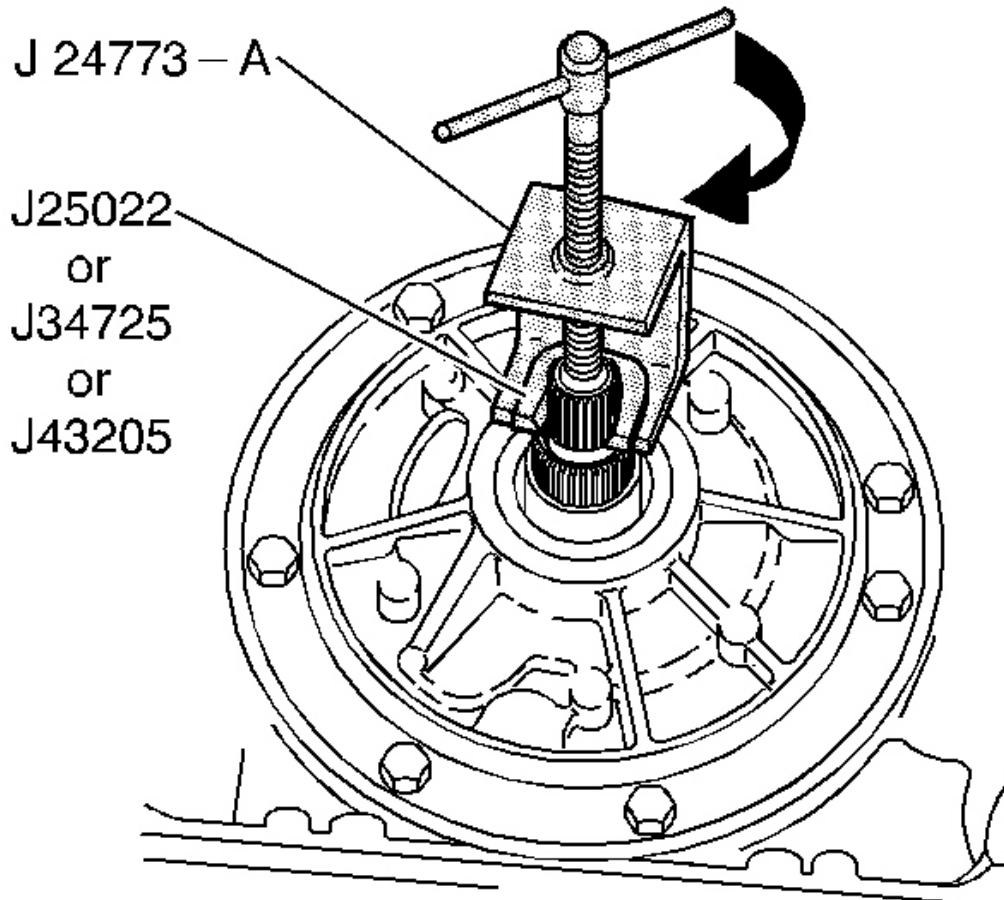

Fig. 408: Identifying J 24773-A
Courtesy of GENERAL MOTORS CORP.

2. Install the **J 24773-A** . See **Special Tools**.

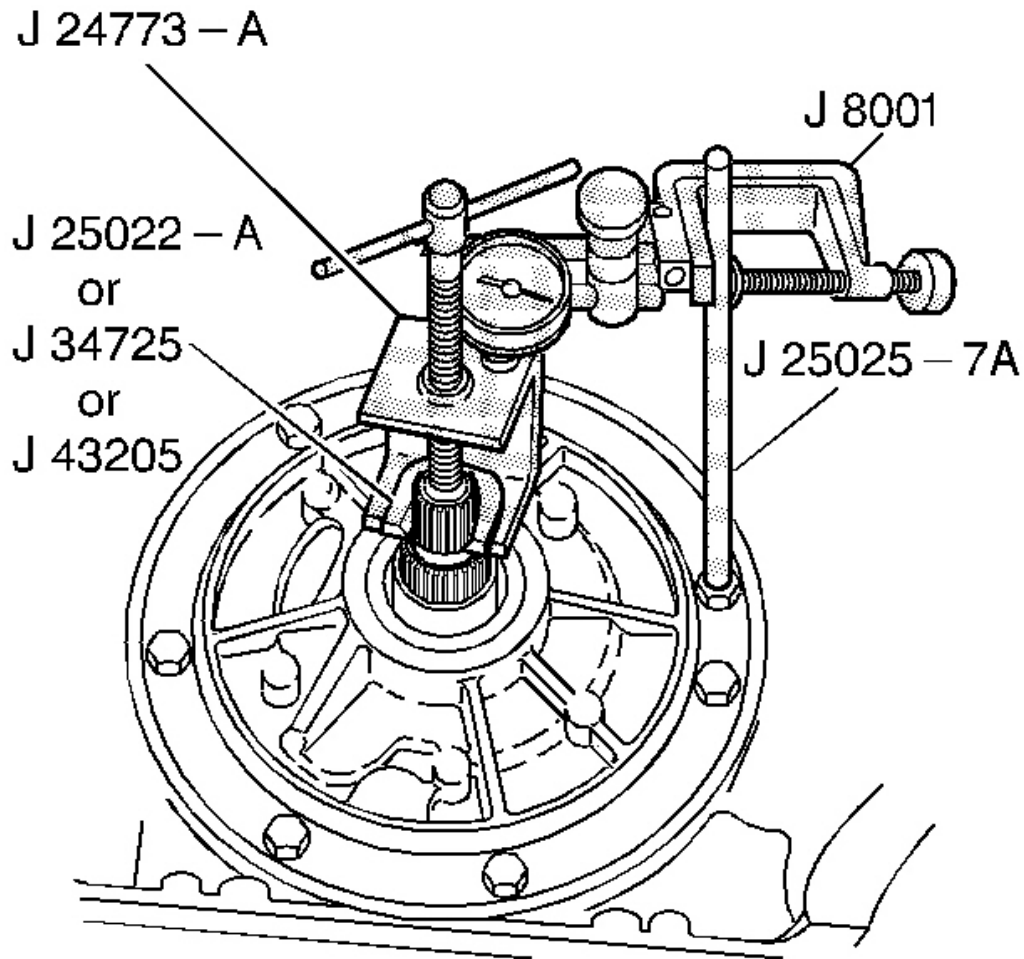

Fig. 409: Installing J 25025-7A With J 8001
Courtesy of GENERAL MOTORS CORP.

3. Remove an oil pump bolt.
4. Install **J 25025-7A** (or a 278 mm or 11 in bolt) and lock nut. See **Special Tools**.
5. Install **J 8001** .

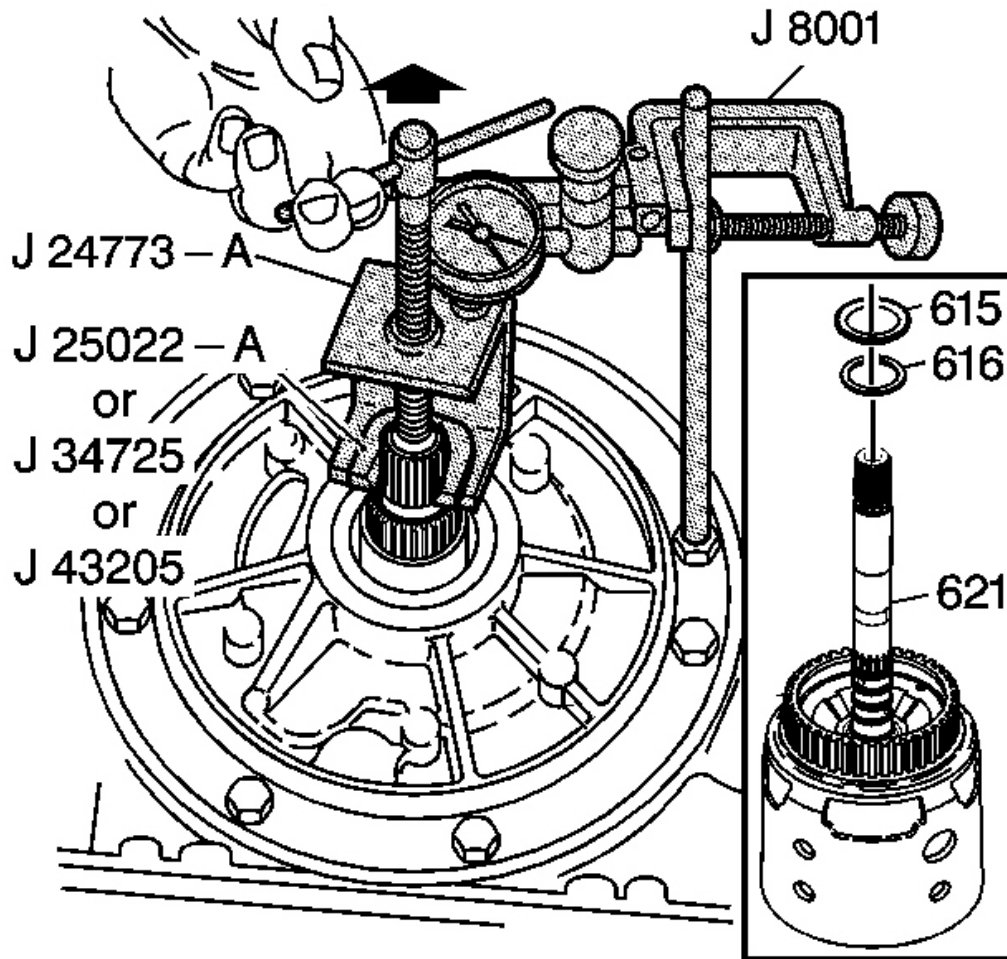

Fig. 410: Installing J 8001 & Setting It To Zero
 Courtesy of GENERAL MOTORS CORP.

6. Set the **J 8001** to zero.
7. Pull up on **J 24773-A** . See **Special Tools**.

Proper end play should be 0.13-0.92 mm (0.005-0.036 in).

8. The selective washer (616), which controls the end play, is located between the input housing (621) and the thrust bearing (615) on the oil pump hub.

2007 Hummer H3

2007 TRANSMISSION Automatic Transmission - 4L60-E/4L65-E/4L70-E - H3

If the end play measurement is incorrect, refer to the table **End Play Specifications** . Choose a new selective washer (616) based on the original selective washer and the information contained in the table.

If the dial indicator shows no end play, the selective washer (616) and thrust bearing (615) may have been misassembled.

9. Correct the end play by changing the selective washer (616).

CONVERTER HOUSING INSTALLATION

Tools Required

J 41510 T-50 Plus Bit. See **Special Tools**.

Installation Procedure

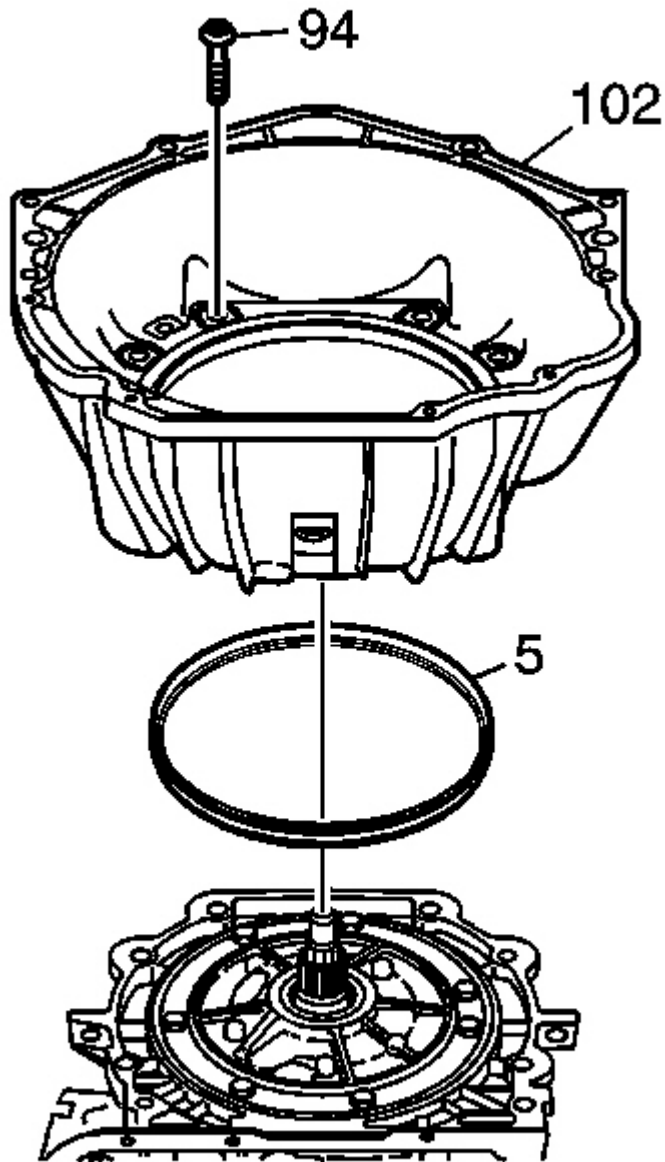

Fig. 411: View Of Oil Pump Seal, Converter Housing & Bolts
Courtesy of GENERAL MOTORS CORP.

IMPORTANT:

- Ensure the converter housing and case face are clean before installing a new pump seal.

- **When installing a new oil pump seal (5), the seal will protrude slightly above the case surface. The oil pump seal is a wedge design that will conform to the surfaces between the oil pump body and the transmission case as the converter housing (102) is installed.**

1. Install the oil pump seal (5). Seat oil pump seal (5) by hand, between pump body and case. Ensure the seal is evenly seated.
2. Install the converter housing (102).

NOTE: Refer to **FASTENER NOTICE** .

3. Using the **J 41510** , install the converter housing bolts (94) to the transmission case. See **Special Tools**.

Tighten:

- Tighten converter housing bolts evenly in a star pattern sequence.
- Tighten the converter housing bolts (94) to 65-75 N.m (48-55 lb ft).

TURBINE SHAFT O-RING INSTALLATION

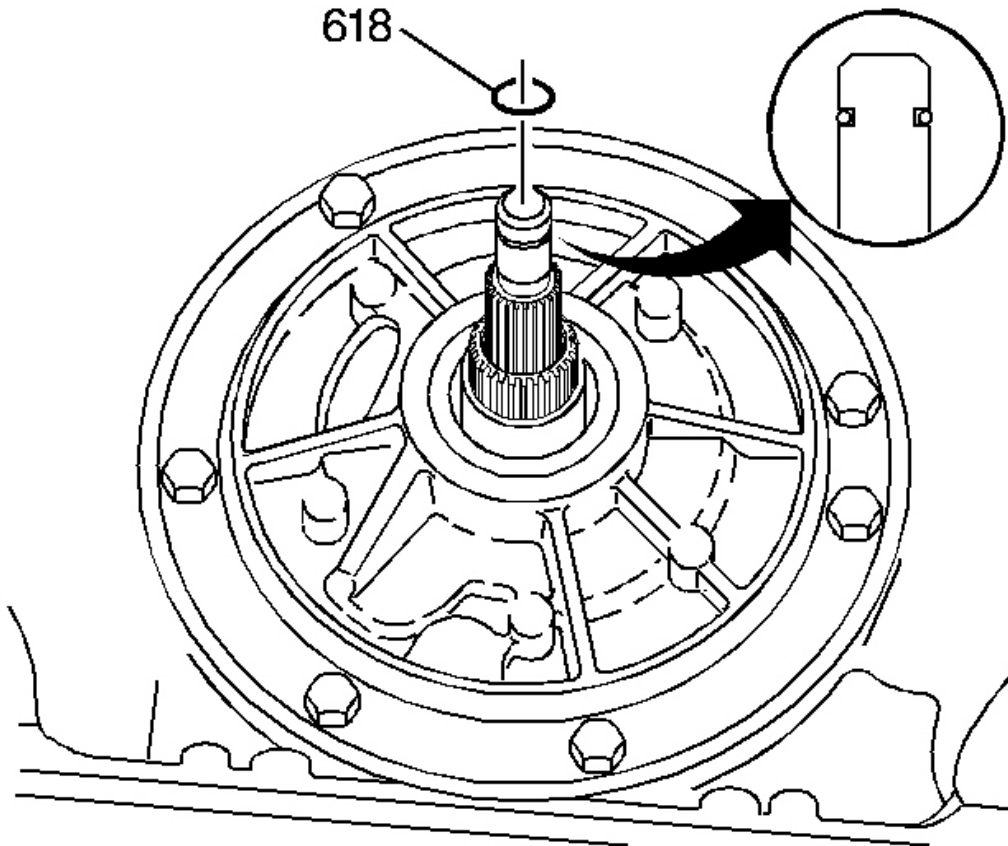

Fig. 412: Identifying Turbine Shaft O-Ring
Courtesy of GENERAL MOTORS CORP.

Install the O-ring (618) on the turbine shaft. O-Ring location is location dependent.

CONTROL VALVE BODY DISASSEMBLE

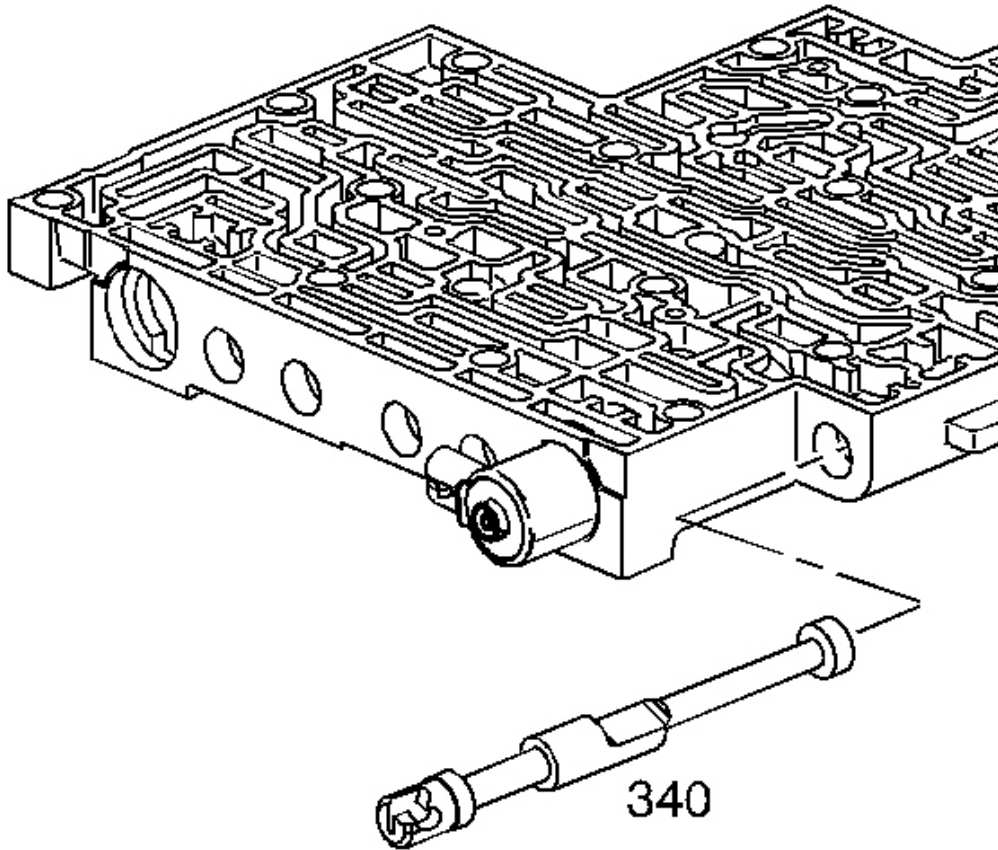

Fig. 413: View Of Manual Valve
Courtesy of GENERAL MOTORS CORP.

CAUTION: Refer to Valve Springs Can Be Tightly Compressed
Caution .

1. Remove the manual valve (340).

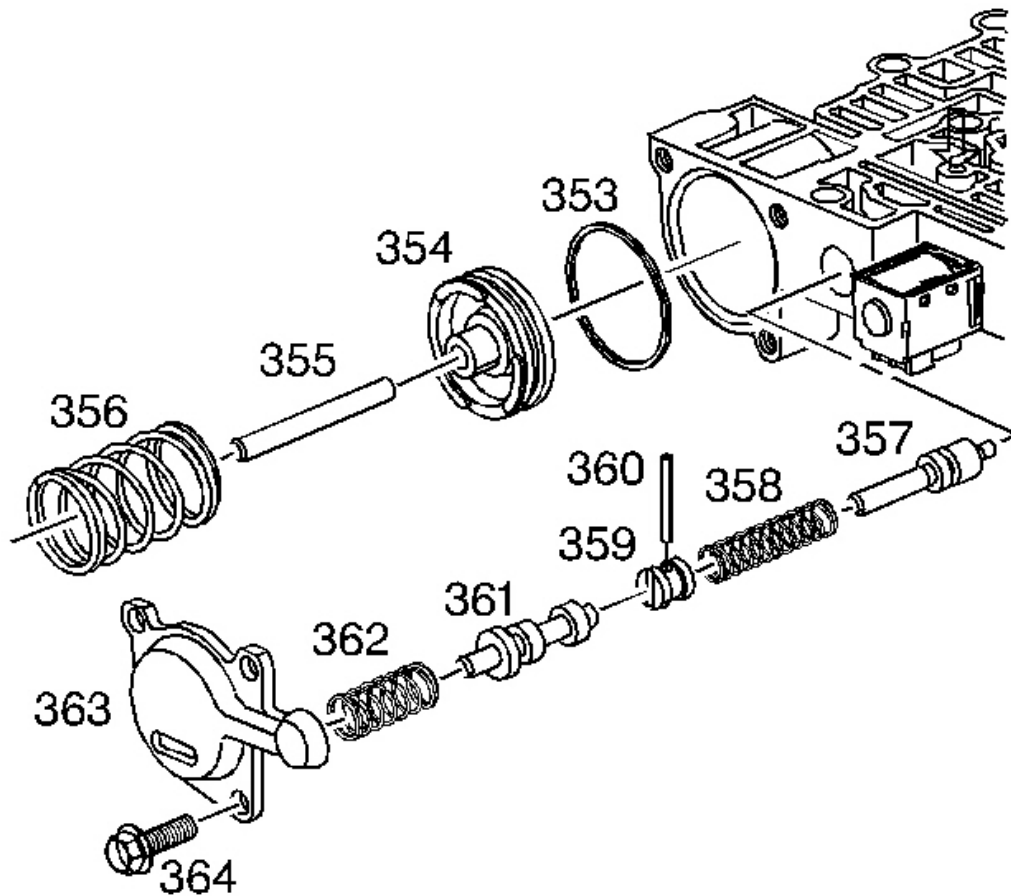

Fig. 414: Exploded View Of Forward Abuse & Low Overrun Components
Courtesy of GENERAL MOTORS CORP.

2. Remove the forward accumulator cover bolts (364) and the forward accumulator cover (363).
3. Remove the forward accumulator spring (356), forward accumulator piston (354) and the forward accumulator pin (355).
4. Remove the low overrun valve spring (362) and the low overrun valve (361).
5. Remove the coiled spring pin (360) and the bore plug (359).
6. Remove the forward abuse valve spring (358) and the forward abuse valve (357).

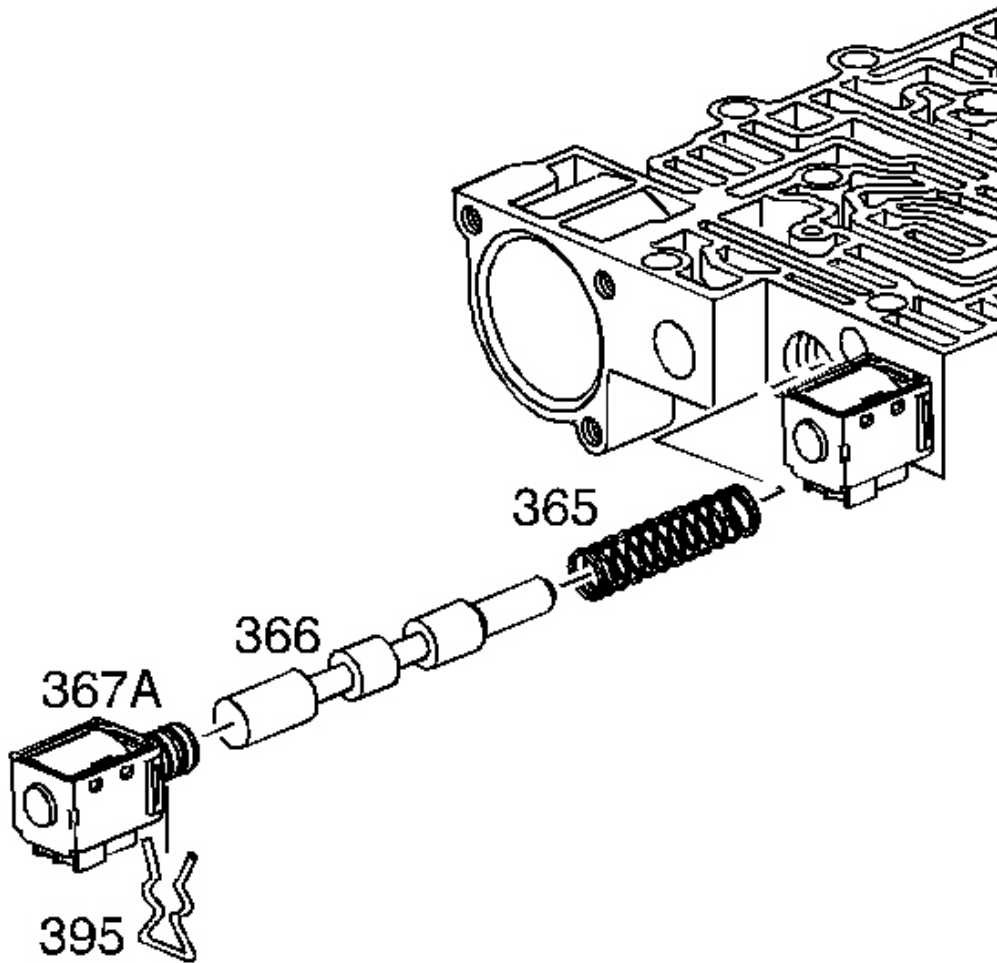

Fig. 415: Removing The 1-2 Shift Solenoid Retainer And The 1-2 Shift Solenoid
Courtesy of GENERAL MOTORS CORP.

7. Remove the solenoid retainer (395) and the 1-2 shift solenoid (367A).
8. Remove the 1-2 shift valve (366) and the 1-2 shift valve spring (365).

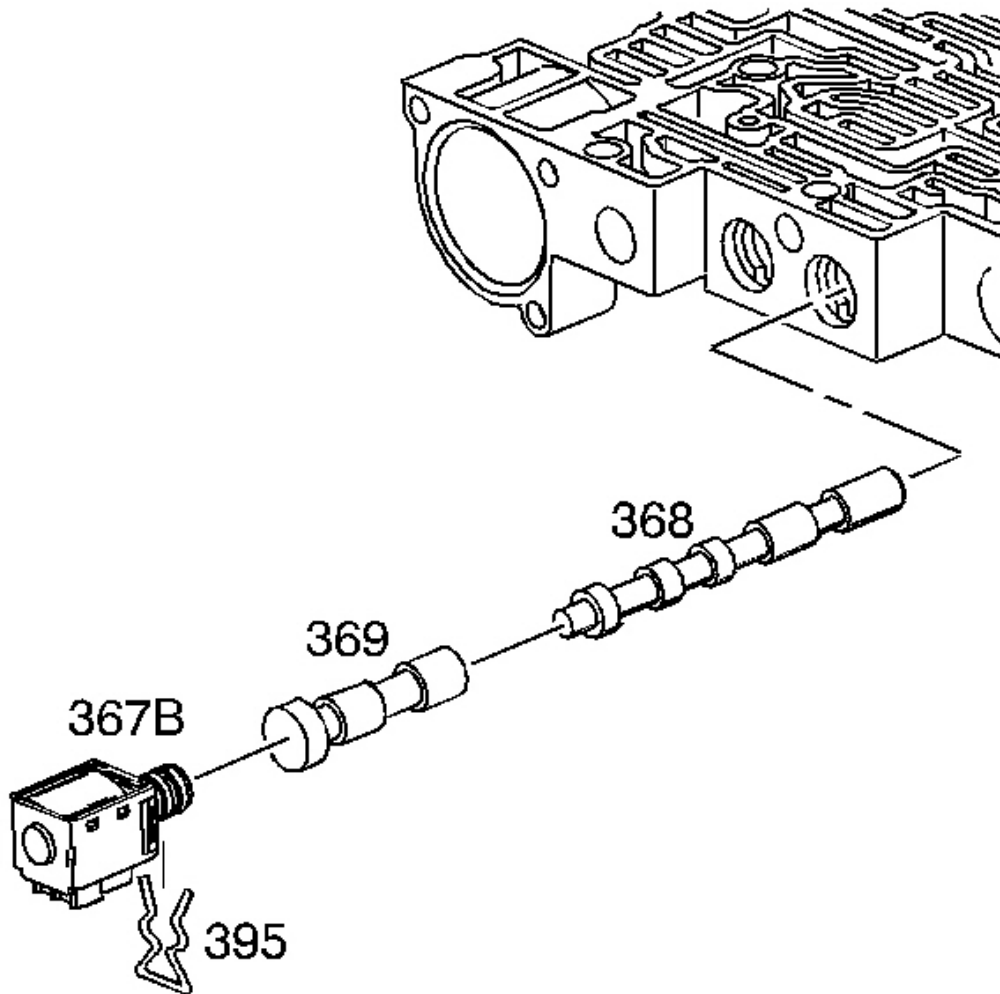
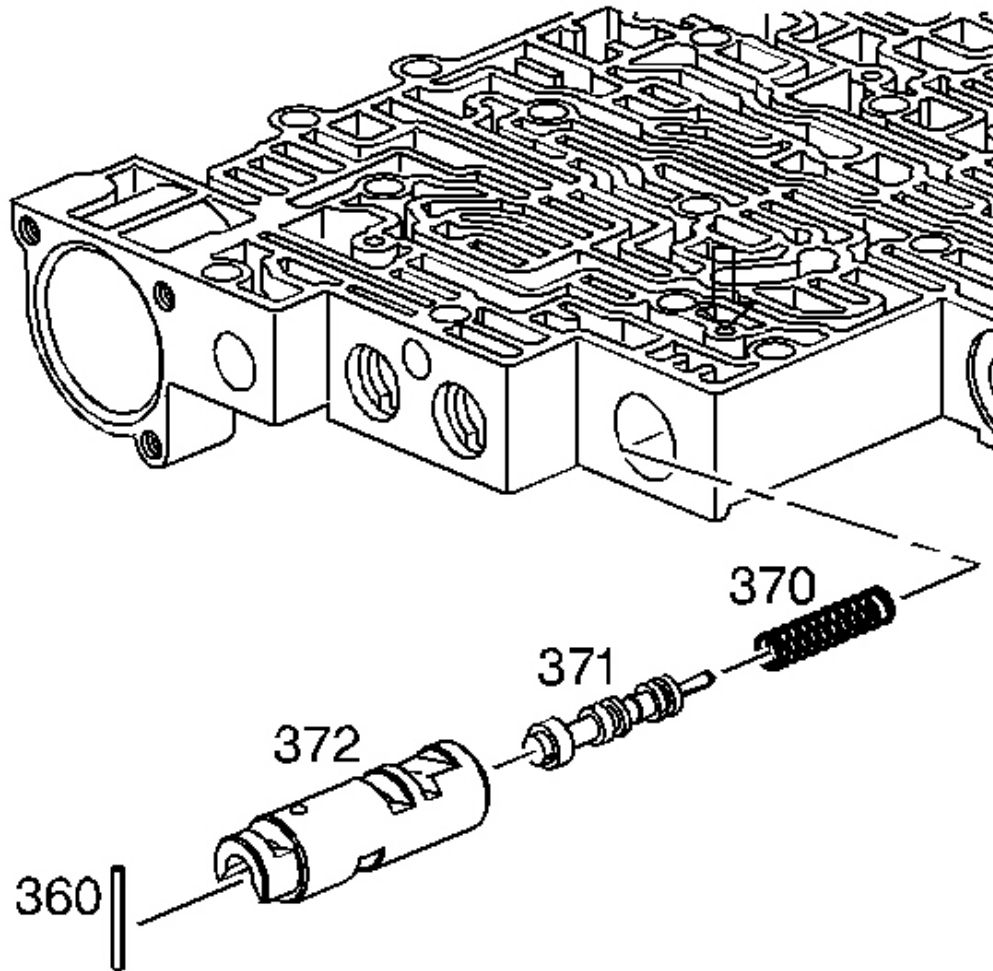

Fig. 416: Removing The 2-3 Shift Solenoid Retainer And The 2-3 Shift Solenoid
Courtesy of GENERAL MOTORS CORP.

9. Remove the solenoid retainer (395) and the 2-3 shift solenoid (367B).
10. Remove the 2-3 shuttle valve (369) and the 2-3 shift valve (368).



**Fig. 417: View Of 1-2 Accumulator Valve & 1-2 Accumulator Valve Sleeve
Courtesy of GENERAL MOTORS CORP.**

11. Remove the coiled spring pin (360).
12. Remove the 1-2 accumulator valve sleeve (372).
13. Remove the 1-2 accumulator valve (371) and the 1-2 accumulator valve spring (370).

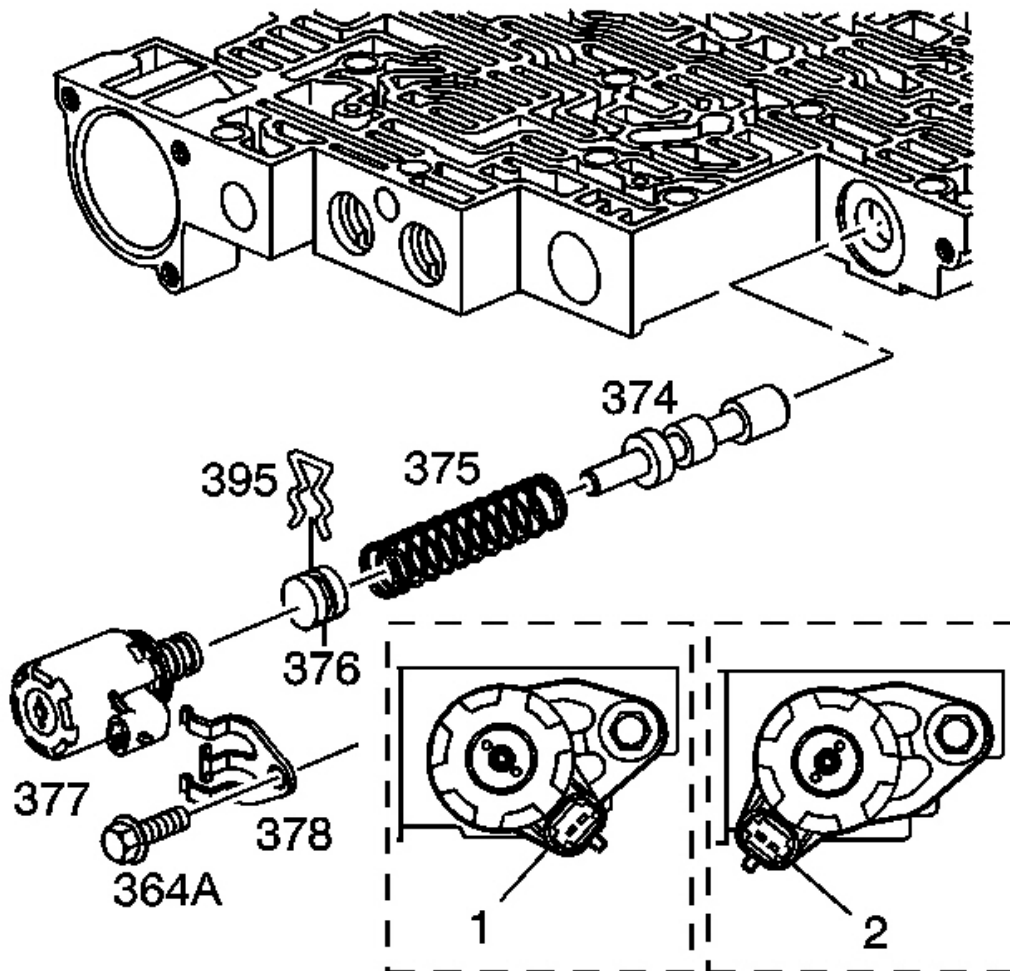

Fig. 418: View Of Pressure Control Solenoid & Components
 Courtesy of GENERAL MOTORS CORP.

14. Remove the solenoid retainer bolt (364A) and the solenoid retainer (378). Remove the pressure control solenoid (377), note orientation upon removal.

CAUTION: Refer to Valve Springs Can Be Tightly Compressed
Caution .

15. Compress the actuator feed limit valve spring (375).
16. Remove the bore plug retainer (395) and release the spring slowly.

17. Remove the bore plug (376).
18. Remove the actuator feed limit valve spring (375) and the actuator feed limit valve (374).

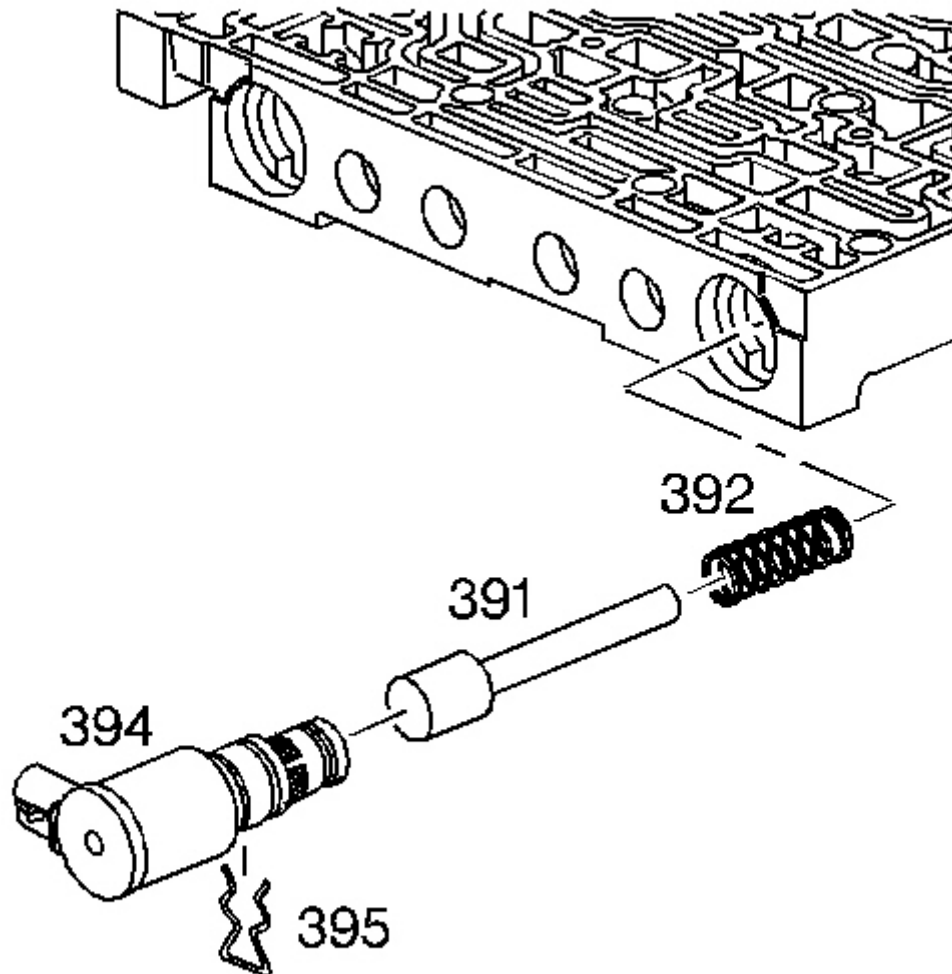

Fig. 419: Removing The 3-2 Control Solenoid Retainer And The 3-2 Control Solenoid
Courtesy of GENERAL MOTORS CORP.

19. Remove the solenoid retainer (395) and the 3-2 control solenoid (394).
20. Remove the 3-2 control valve (391) and the 3-2 control valve spring (392).

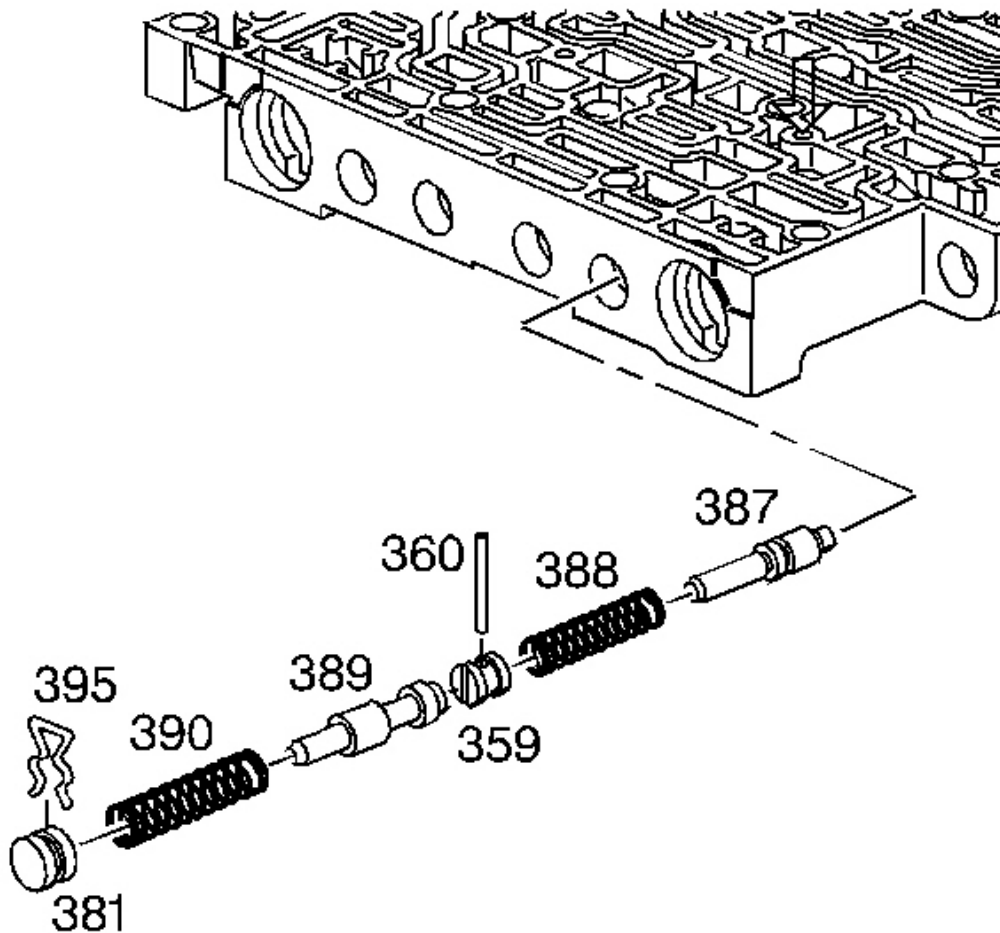

Fig. 420: View Of Reverse Abuse Valve & 3-2 Downshift Valve
Courtesy of GENERAL MOTORS CORP.

CAUTION: Refer to Valve Springs Can Be Tightly Compressed
Caution .

21. Remove the bore plug retainer (395) and the bore plug (381).
22. Remove the 3-2 downshift valve spring (390) and the 3-2 downshift valve (389).
23. Remove the coiled spring pin (360) and the bore plug (359).
24. Remove the reverse abuse valve spring (388) and the reverse abuse valve (387).

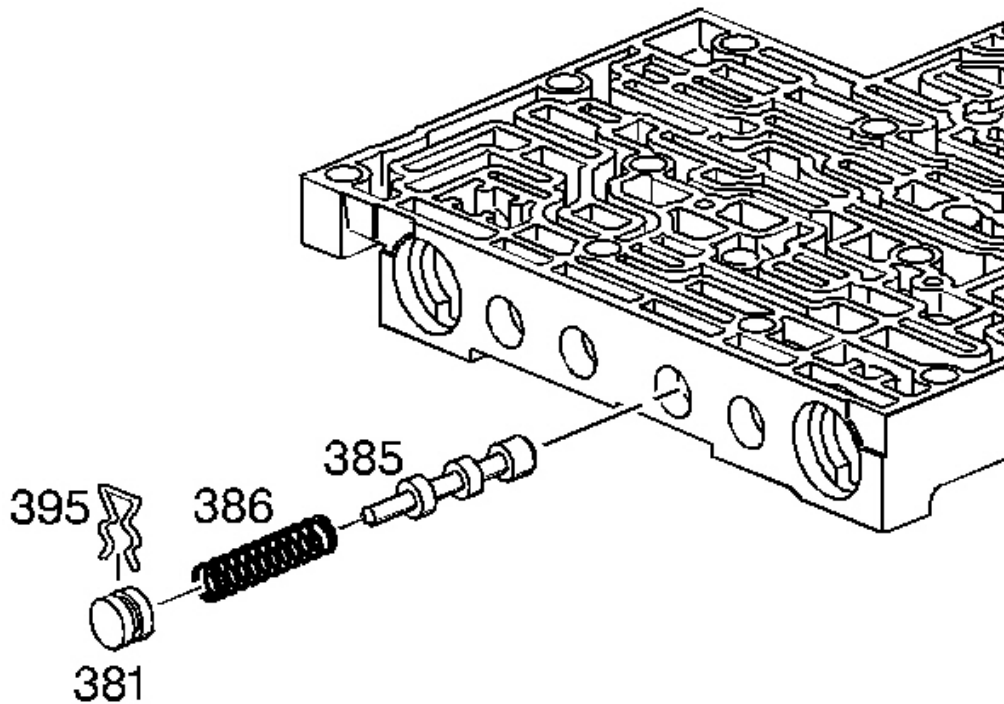

Fig. 421: Locating 3-4 Shift Valve
Courtesy of GENERAL MOTORS CORP.

CAUTION: Refer to Valve Springs Can Be Tightly Compressed
Caution .

25. Remove the bore plug retainer (395) and the bore plug (381).
26. Remove the 3-4 shift valve spring (386) and the 3-4 shift valve (385).

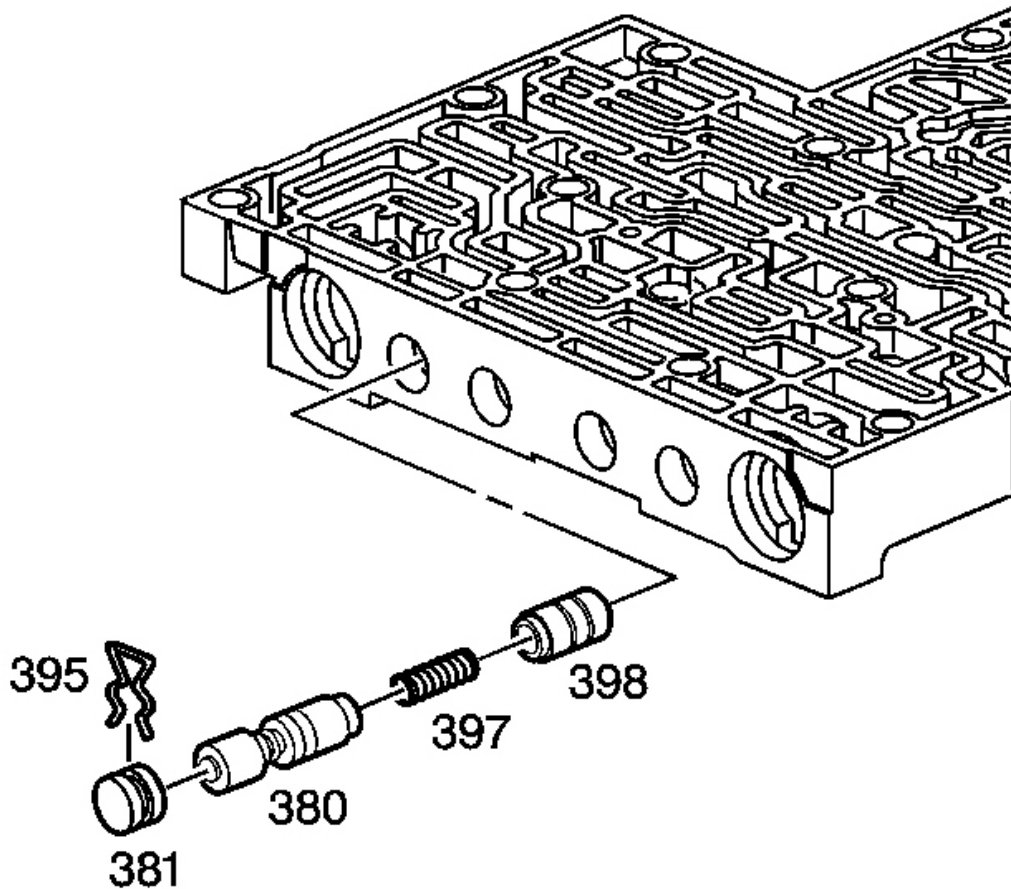

Fig. 422: Identifying Isolator Valve & Regulator Apply Valve
Courtesy of GENERAL MOTORS CORP.

27. Remove the bore plug retainer (395) and the bore plug (381).
28. Remove the regulator apply valve (380) and the regulator apply spring (397) and the isolator valve (398).

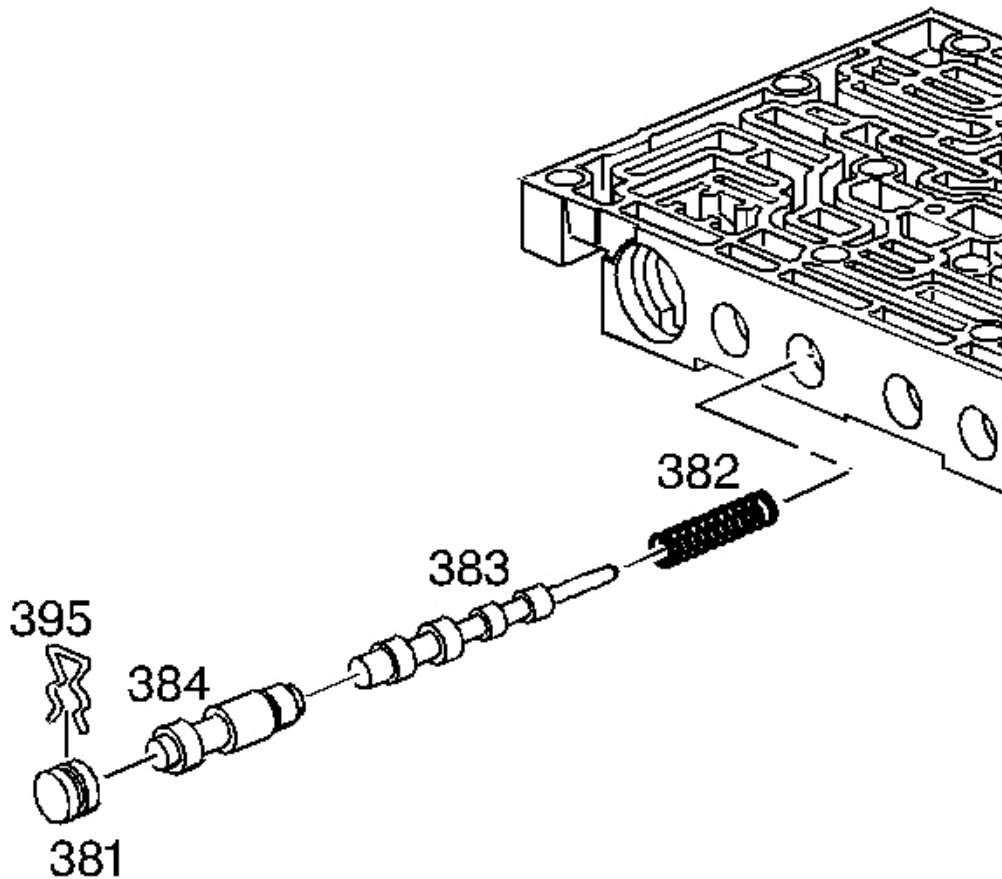

Fig. 423: View Of 4-3 Sequence Valve & 3-4 Relay Valve
Courtesy of GENERAL MOTORS CORP.

29. Remove the bore plug retainer (395) and the bore plug (381).
30. Remove the 3-4 relay valve (384) and the 4-3 sequence valve (383) and the 4-3 sequence valve spring (382).

CONTROL VALVE BODY ASSEMBLY

Inspection Procedure

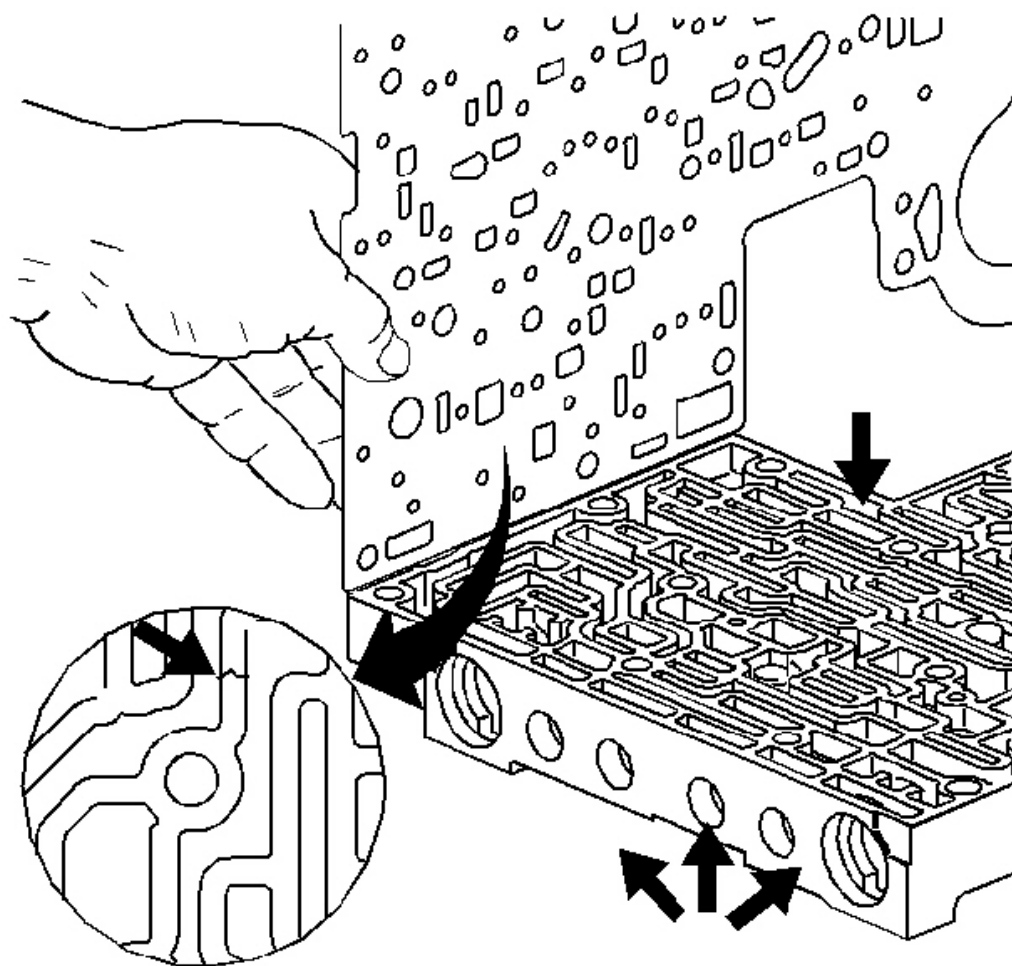

Fig. 424: Inspecting Control Valve Body For Channel Witness Marks
Courtesy of GENERAL MOTORS CORP.

1. Inspect the valve body to spacer plate gasket for valve body channel witness marks. The witness marks should be complete. Incomplete witness marks may be caused by an uneven case surface. Incomplete witness marks may also be caused by cross-channel leaks.
2. Inspect the valve body casting for the following conditions:
 - Porosity
 - Cracks
 - Damaged machined surfaces

- Chips or debris

Cleaning Procedure

1. Clean all the valves, springs, bushings and the control valve body in clean solvent.
2. Dry all the parts using compressed air.

Installation Procedure

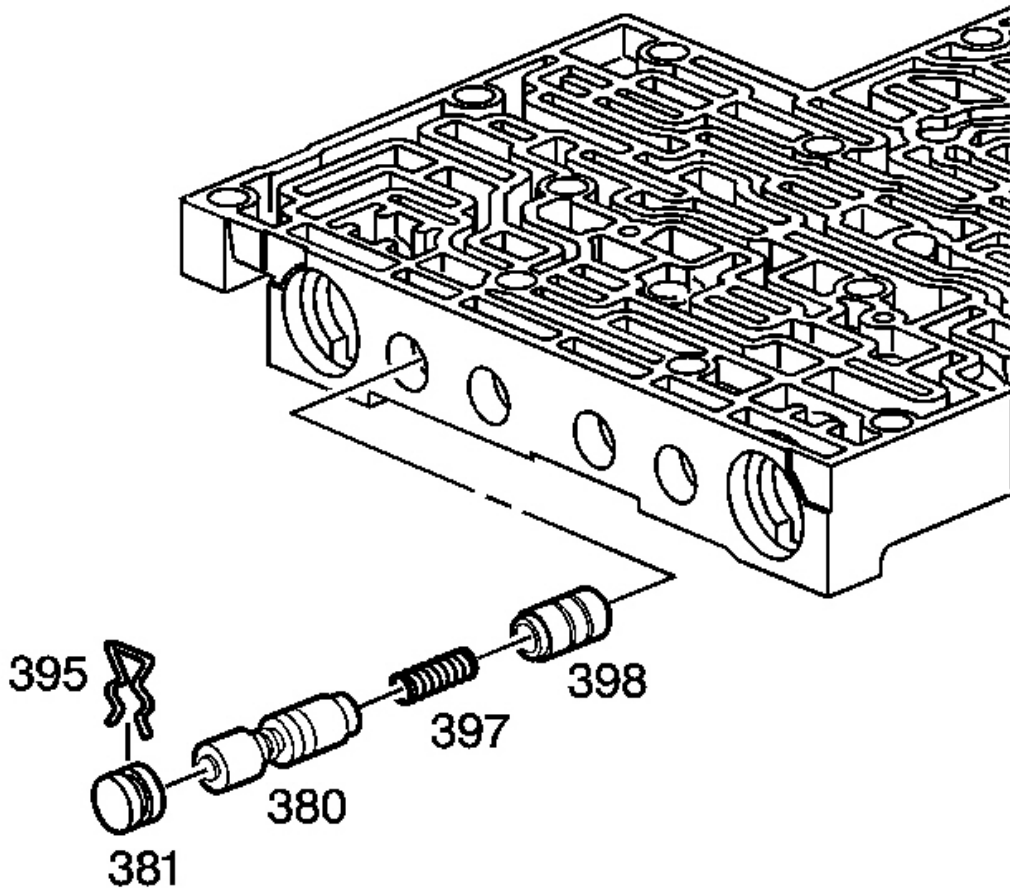

Fig. 425: Identifying Isolator Valve & Regulator Apply Valve
Courtesy of GENERAL MOTORS CORP.

CAUTION: Refer to Valve Springs Can Be Tightly Compressed

Caution .

IMPORTANT: Lubricate all parts with DEXRON®VI automatic transmission fluid before installation.

1. Install the following items:
 1. The isolator valve (398)
 2. The regulator apply spring (397)
 3. The regulator apply valve (380)
 4. The bore plug (381)
 5. The bore plug retainer (395)

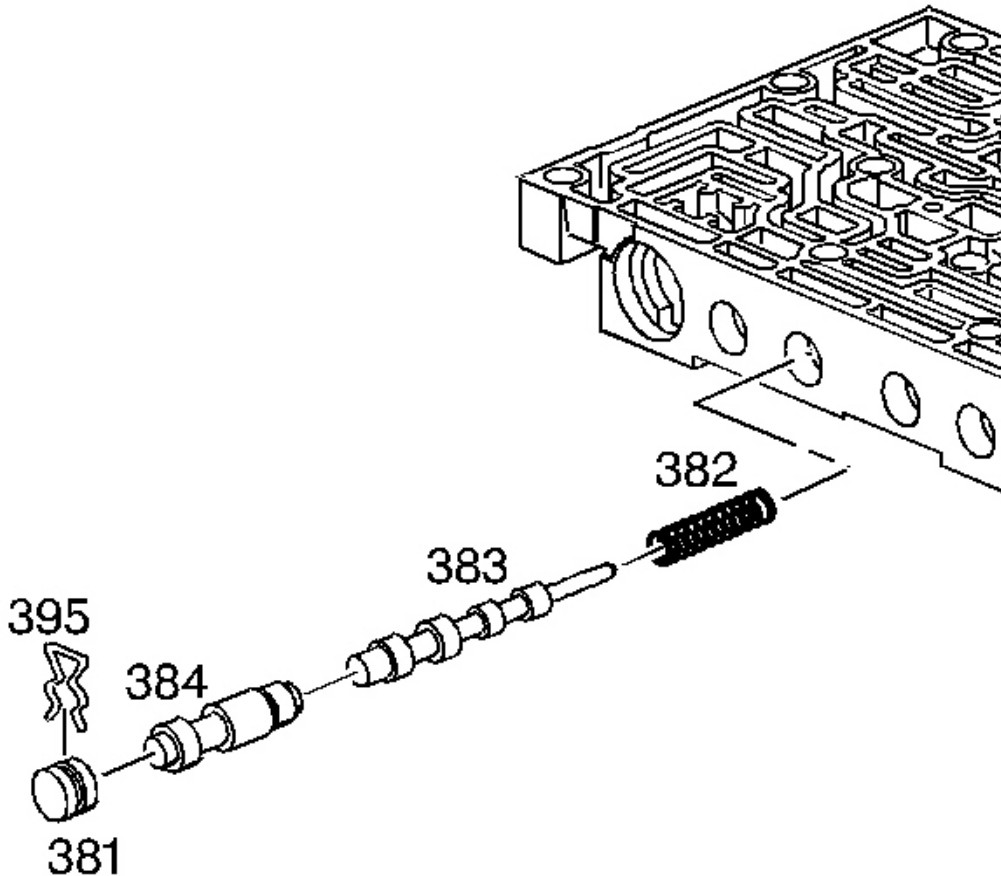

Fig. 426: View Of 4-3 Sequence Valve & 3-4 Relay Valve
Courtesy of GENERAL MOTORS CORP.

2. Install the following items:
 1. The 4-3 sequence valve spring (382)
 2. The 4-3 sequence valve (383)
 3. The 3-4 relay valve (384)
 4. The bore plug (381)
 5. The bore plug retainer (395)

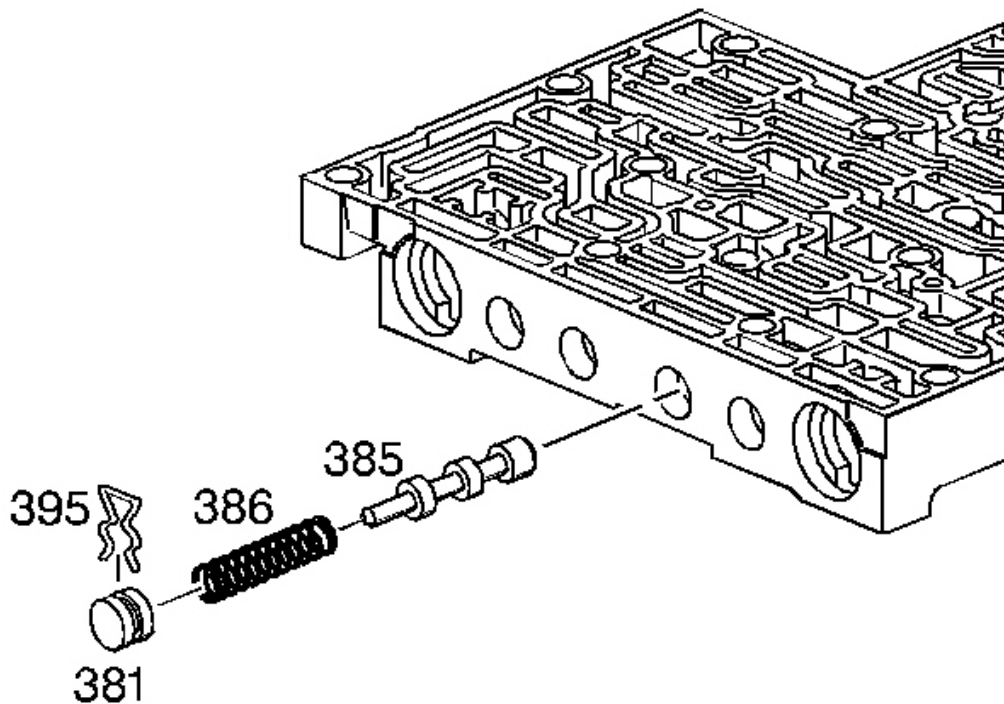

Fig. 427: Locating 3-4 Shift Valve
Courtesy of GENERAL MOTORS CORP.

3. Install the following items:
 1. The 3-4 shift valve (385)
 2. The 3-4 shift valve spring (386)

3. The bore plug (381)
4. The bore plug retainer (395)

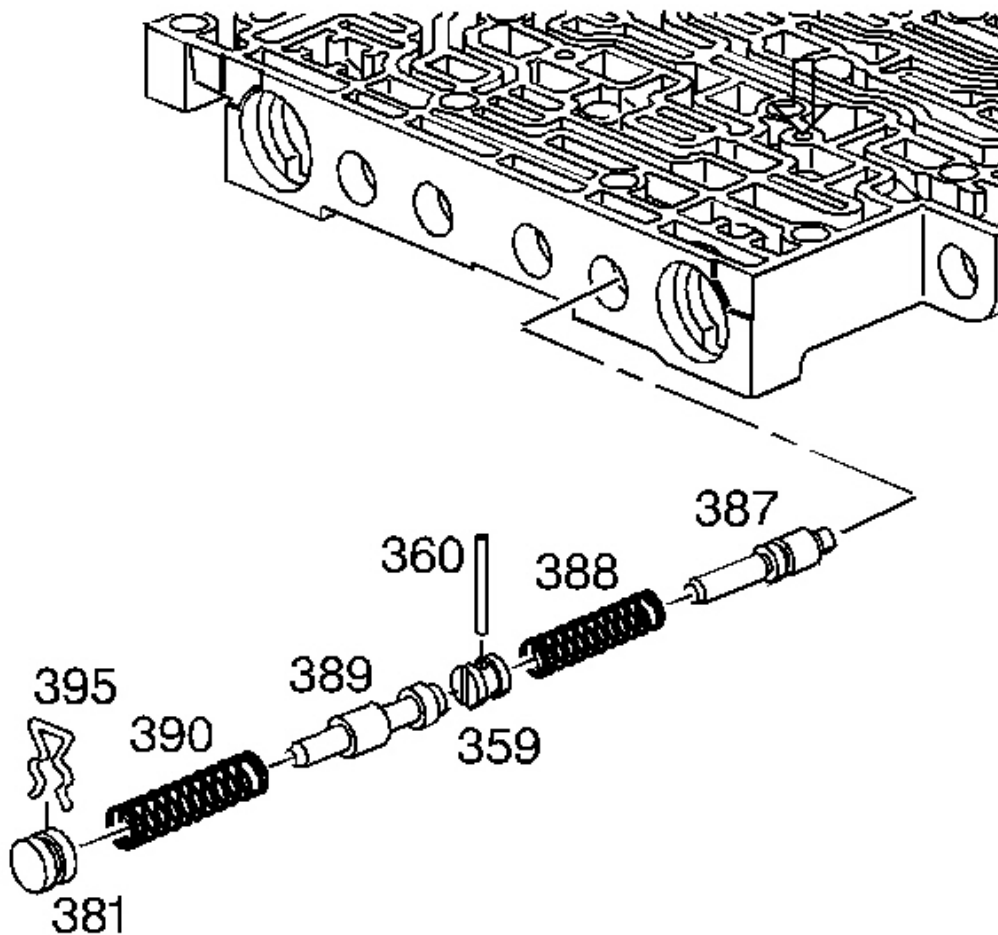

Fig. 428: View Of Reverse Abuse Valve & 3-2 Downshift Valve
Courtesy of GENERAL MOTORS CORP.

4. Install the following items:
 1. The reverse abuse valve (387)
 2. The reverse abuse valve spring (388)
 3. The bore plug (359)

4. The coiled spring pin (360)
5. The 3-2 downshift valve (389)
6. The 3-2 downshift valve spring (390)
7. The bore plug (381)
8. The bore plug retainer (395)

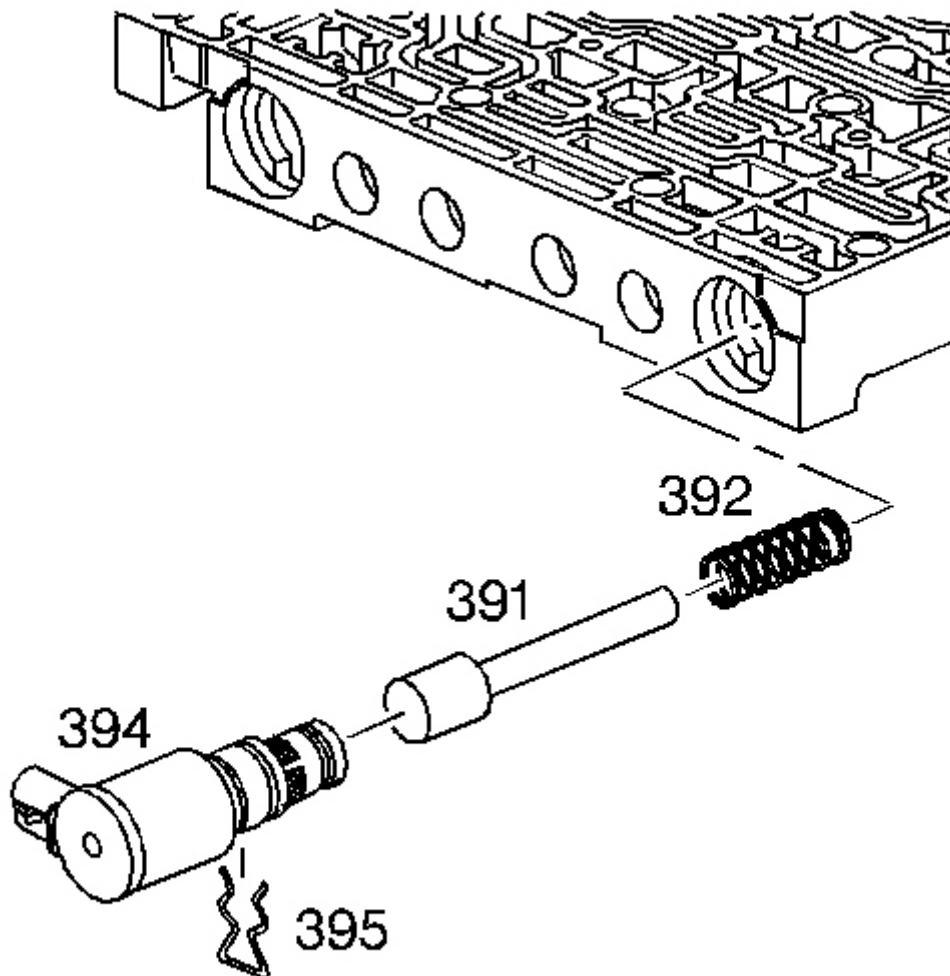

Fig. 429: Removing The 3-2 Control Solenoid Retainer And The 3-2 Control Solenoid

Courtesy of GENERAL MOTORS CORP.

NOTE: Be sure all solenoids are installed with the electrical connectors facing the non-machined (cast) side of the valve body; otherwise, the solenoids will bind against the transmission case as the valve body bolts are tightened and damage may occur.

5. Install the following items:
 1. The 3-2 control valve spring (392)
 2. The 3-2 control valve (391)
 3. The 3-2 control solenoid (394)
 4. The solenoid retainer (395)

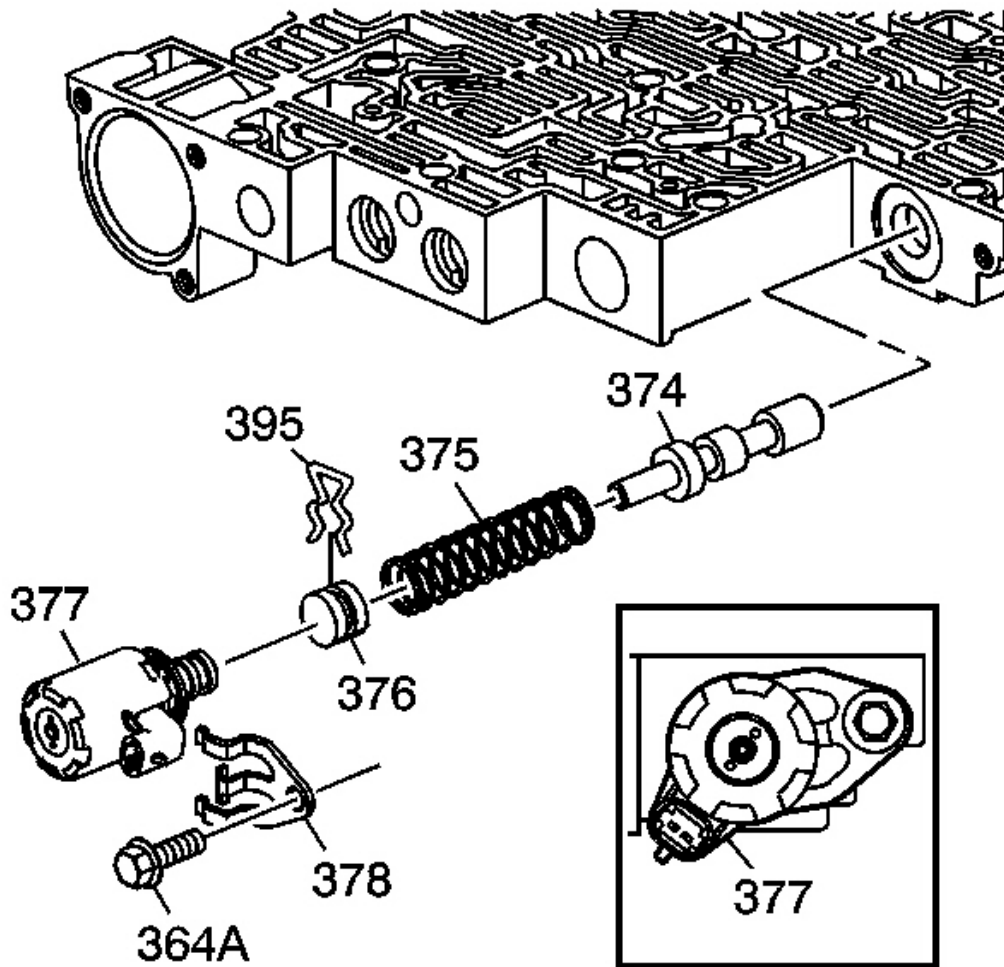

Fig. 430: View Of Valve Body Solenoids & Components
 Courtesy of GENERAL MOTORS CORP.

NOTE: Be sure all solenoids are installed with the electrical connectors facing the non-machined (cast) side of the valve body; otherwise, the solenoids will bind against the transmission case as the valve body bolts are tightened and damage may occur.

6. Install the following items:
 1. The actuator feed limit valve (374)

2007 Hummer H3

2007 TRANSMISSION Automatic Transmission - 4L60-E/4L65-E/4L70-E - H3

2. The actuator feed limit valve spring (375)
3. The bore plug (376)
4. The bore plug retainer (395)
5. The pressure control solenoid (377)
6. The solenoid retainer (378)

NOTE: Refer to Fastener Notice .

7. The solenoid retainer bolt (364)

Tighten: Tighten the bolt to 8-14 N.m (6-10 lb ft).

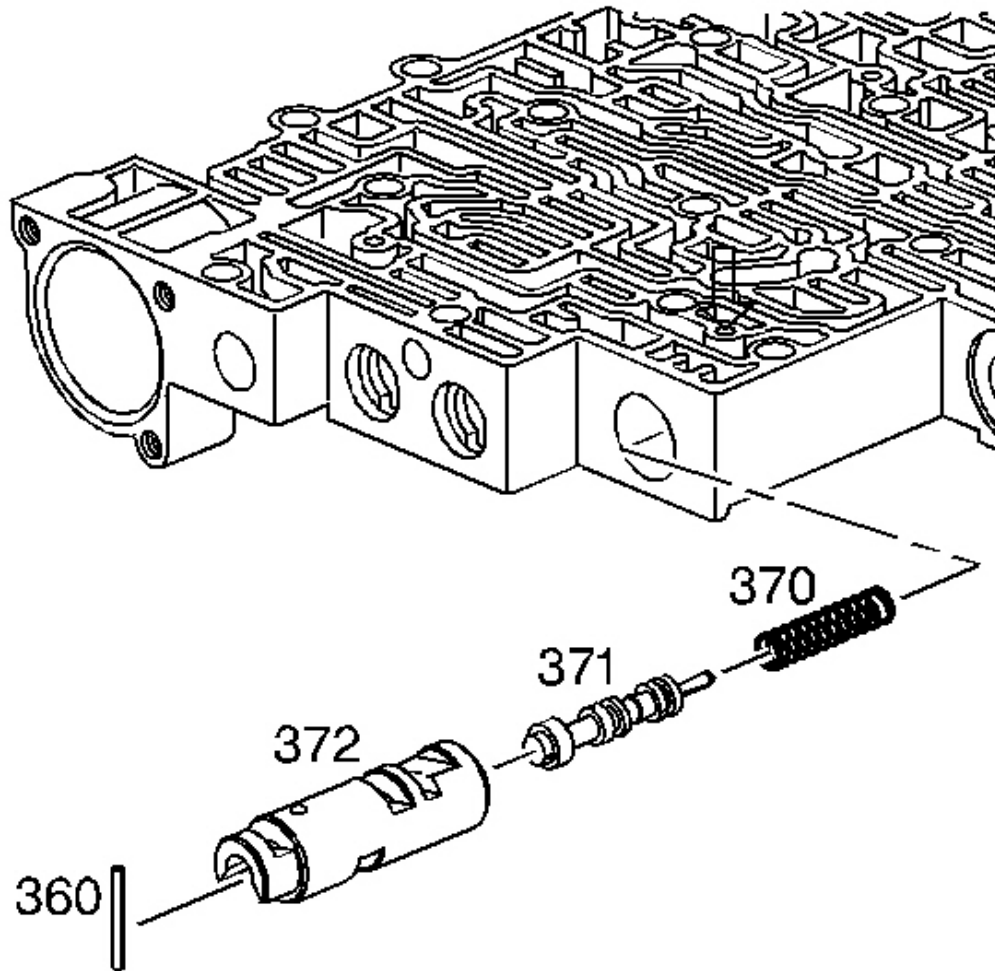

**Fig. 431: View Of 1-2 Accumulator Valve & 1-2 Accumulator Valve Sleeve
Courtesy of GENERAL MOTORS CORP.**

7. Install the following items:
 1. The 1-2 accumulator valve spring (370)
 2. The 1-2 accumulator valve (371) in the 1-2 accumulator valve sleeve (372)
 3. The 1-2 accumulator valve and sleeve assembly
 4. The coiled spring pin (360)

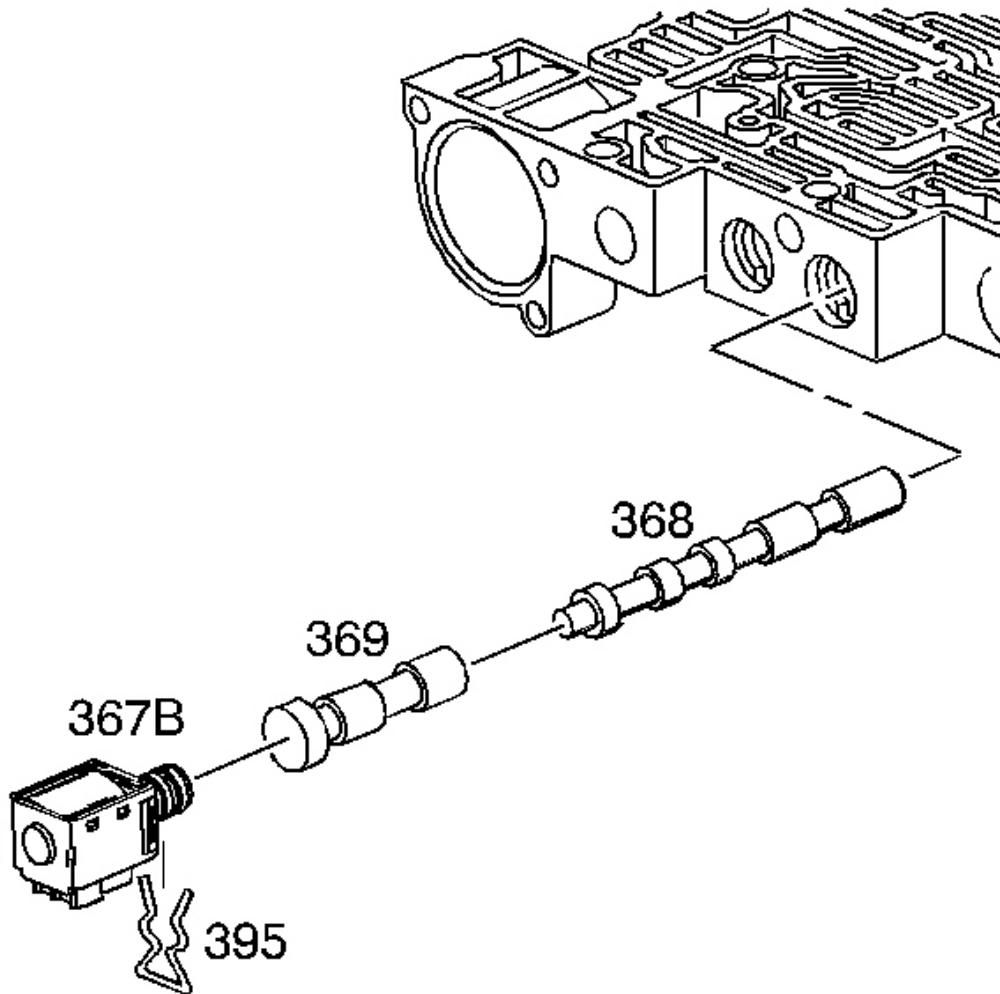

Fig. 432: Removing The 2-3 Shift Solenoid Retainer And The 2-3 Shift Solenoid
Courtesy of GENERAL MOTORS CORP.

NOTE: Be sure all solenoids are installed with the electrical connectors facing the non-machined (cast) side of the valve body; otherwise, the solenoids will bind against the transmission case as the valve body bolts are tightened and damage may occur.

8. Install the following items:

1. The 2-3 shift valve (368)
2. The 2-3 shuttle valve (369)
3. The 2-3 shift solenoid valve (367B)
4. The solenoid retainer (395)

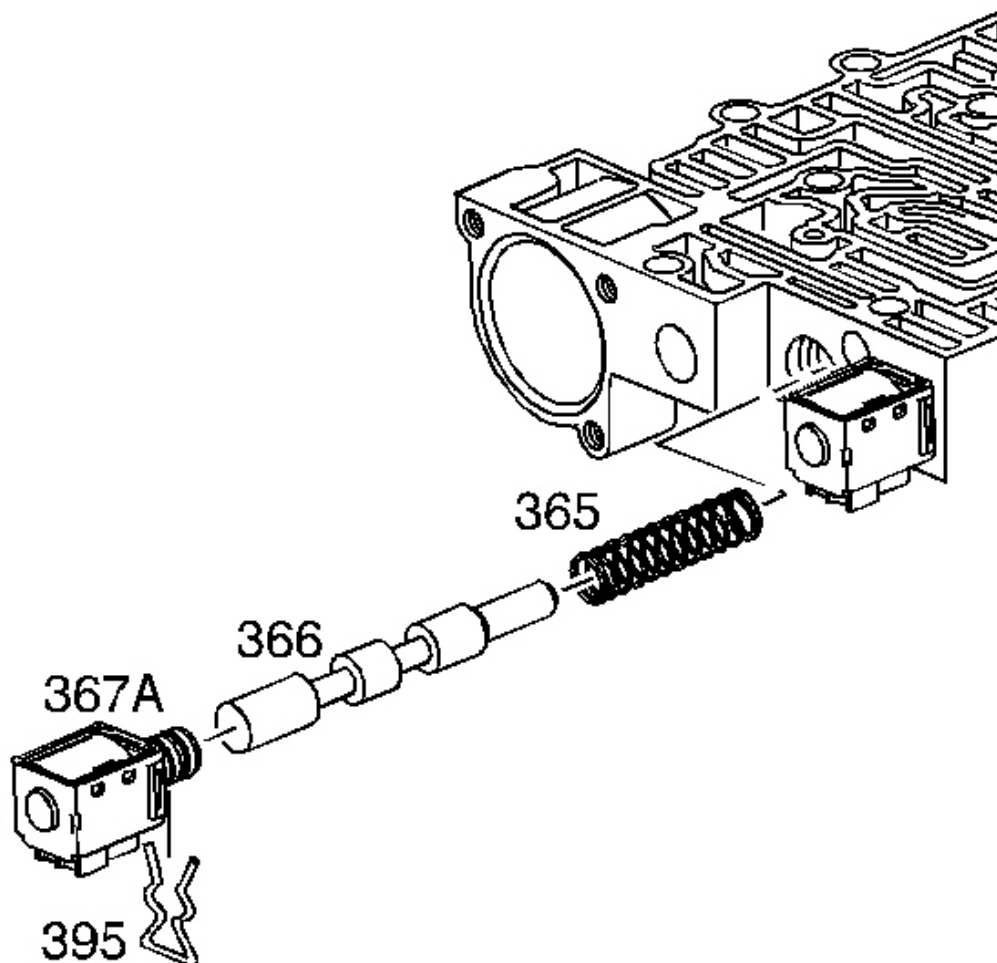

Fig. 433: Removing The 1-2 Shift Solenoid Retainer And The 1-2 Shift Solenoid
Courtesy of GENERAL MOTORS CORP.

NOTE: Be sure all solenoids are installed with the electrical connectors facing the non-machined (cast) side of the valve

body; otherwise, the solenoids will bind against the transmission case as the valve body bolts are tightened and damage may occur.

9. Install the following items:
1. The 1-2 shift valve spring (365)
 2. The 1-2 shift valve (366)
 3. The 1-2 shift solenoid valve (367A)
 4. The solenoid valve retainer (395)

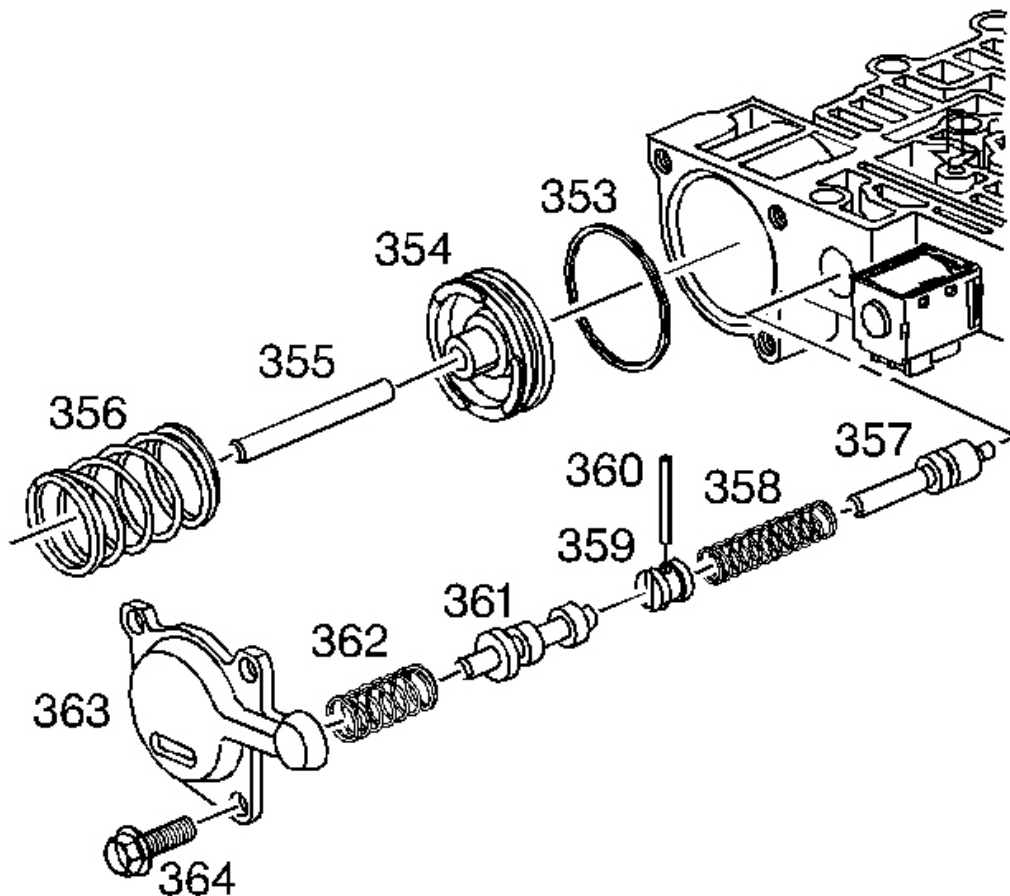

Fig. 434: Exploded View Of Forward Abuse & Low Overrun Components
Courtesy of GENERAL MOTORS CORP.

2007 Hummer H3

2007 TRANSMISSION Automatic Transmission - 4L60-E/4L65-E/4L70-E - H3

10. Install the following items:

1. The forward abuse valve (357)
2. The forward abuse valve spring (358)
3. The bore plug (359)
4. The coiled spring pin (360)
5. The low overrun valve (361)
6. The low overrun valve spring (362)

11. Install the following items:

1. The forward accumulator oil seal (353) on the forward accumulator piston (354)
2. The forward accumulator pin (355)
3. The forward accumulator piston (354)
4. The forward accumulator spring (356)
5. The forward accumulator cover (363)
6. The forward accumulator cover bolts (364)

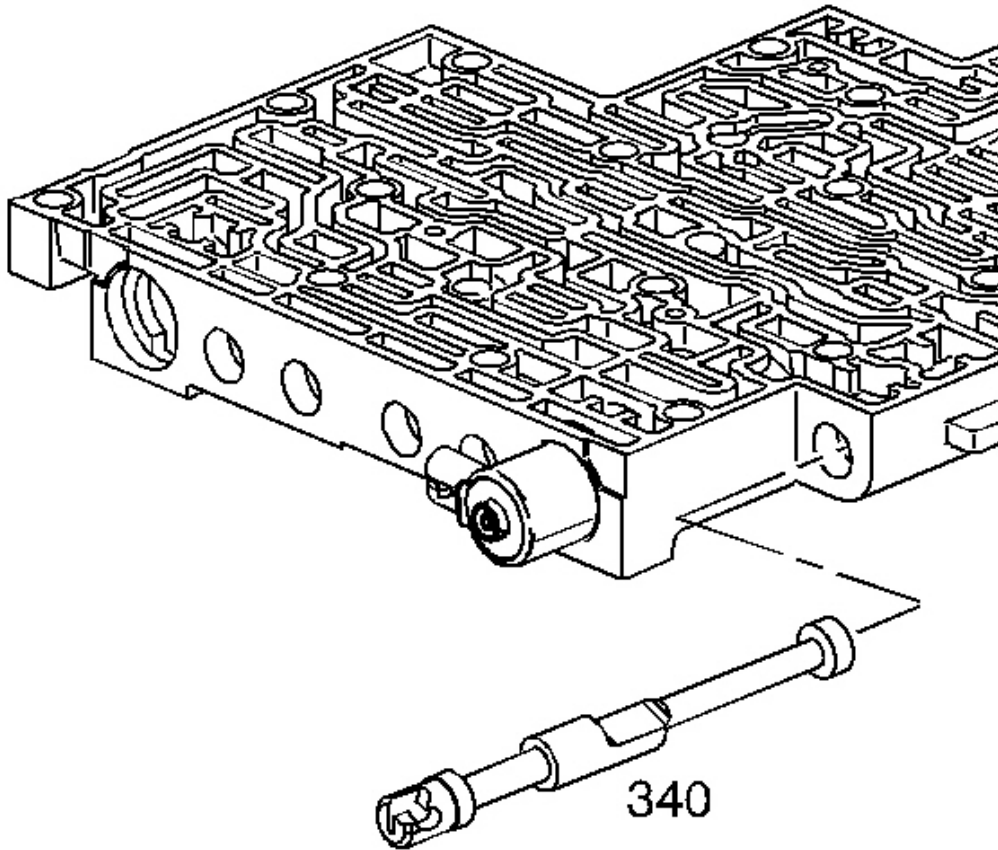

Fig. 435: View Of Manual Valve
Courtesy of GENERAL MOTORS CORP.

12. Install the manual valve (340).

3-4 ACCUMULATOR INSTALLATION

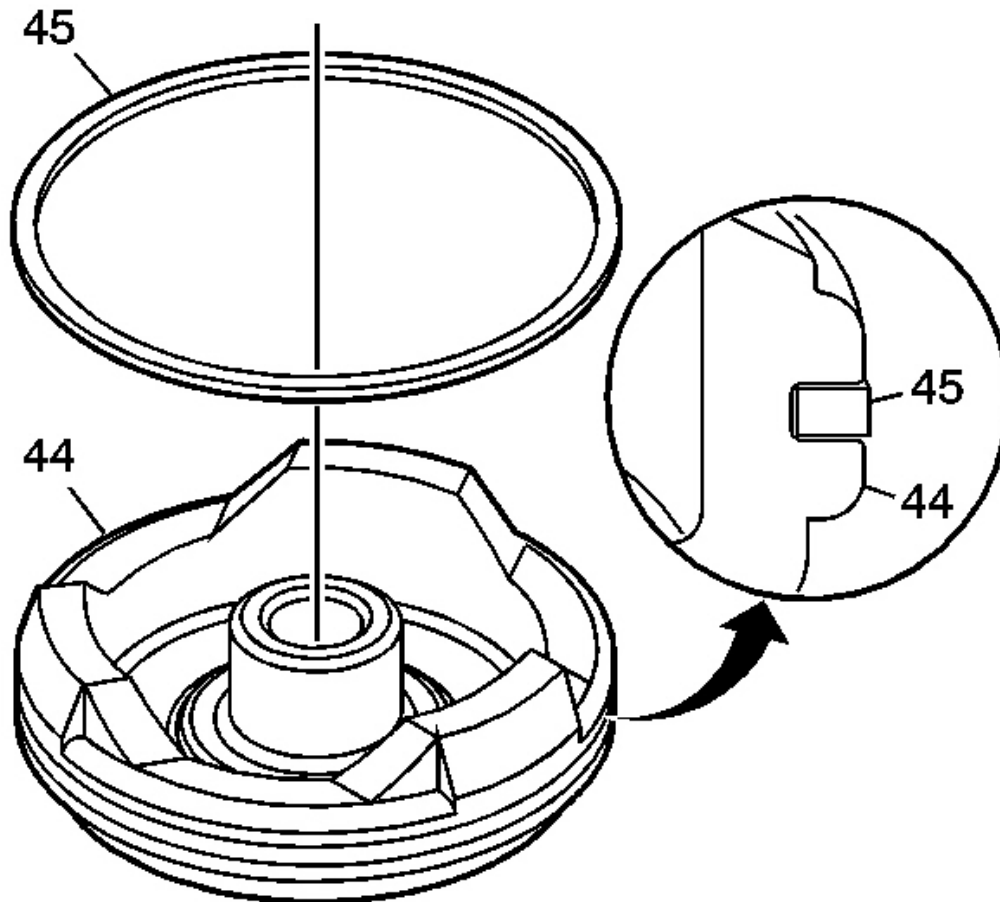

Fig. 436: Identifying 3-4 Accumulator Piston & Piston Oil Seal Ring
Courtesy of GENERAL MOTORS CORP.

1. Inspect the 3-4 accumulator piston (44) for the following conditions:
 - Porosity
 - Cracks
 - Scoring
 - Nicks and scratches
2. Install the 3-4 accumulator piston oil seal ring (45) on the 3-4 accumulator piston (44).

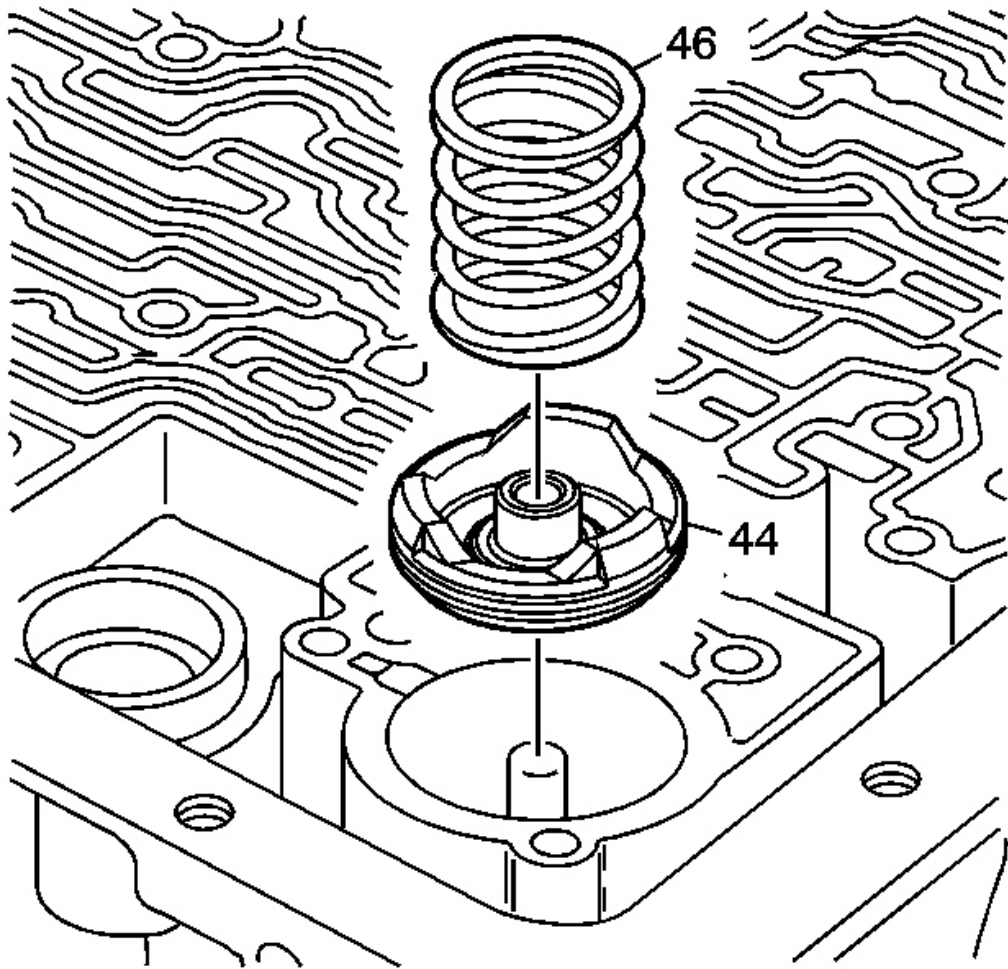

Fig. 437: Identifying 3-4 Accumulator Piston & Accumulator Spring
Courtesy of GENERAL MOTORS CORP.

3. Install the 3-4 accumulator piston (44) and seal assembly into the bore.
4. Inspect the 3-4 accumulator spring (46) for cracks.

IMPORTANT: Some models do not use a 3-4 accumulator spring.

5. Install the 3-4 accumulator spring.

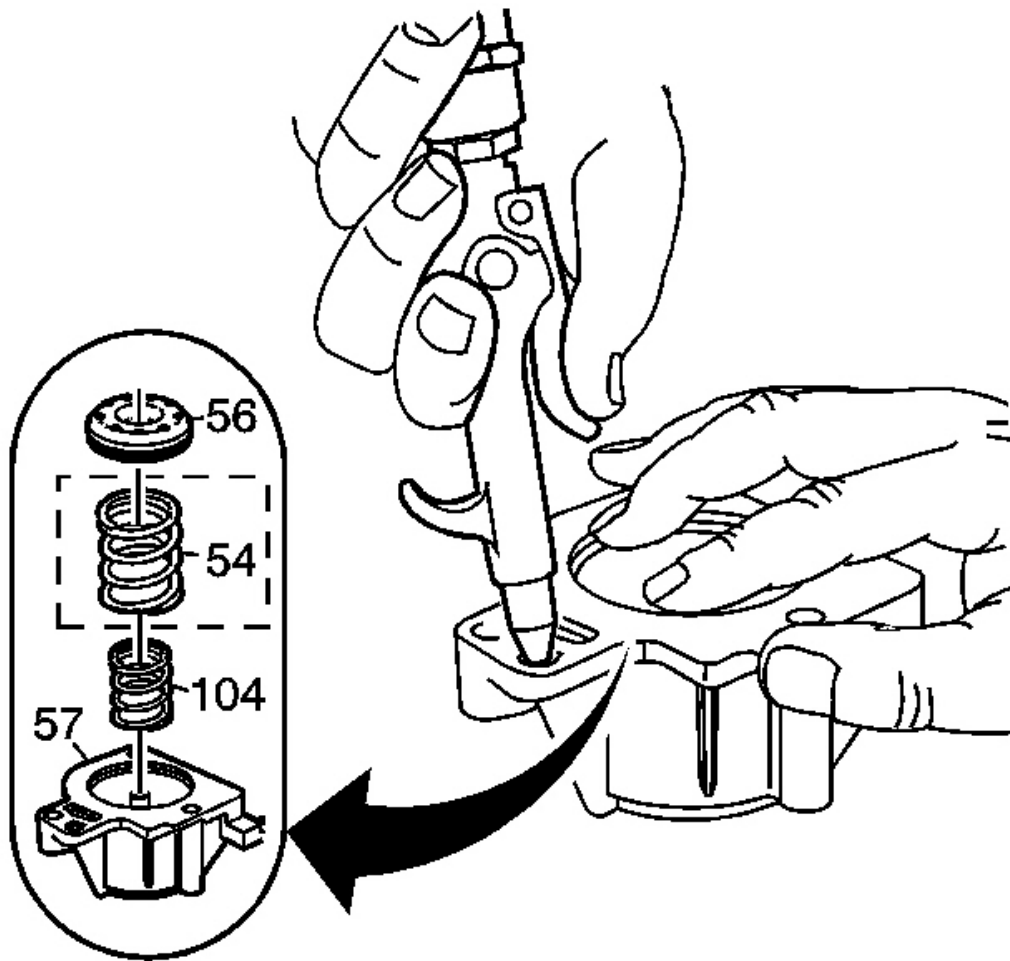

Fig. 438: View Of Accumulator Housing
Courtesy of GENERAL MOTORS CORP.

IMPORTANT: Some models may not use an outer 1-2 accumulator spring (54).

1. Blow air into the 1-2 accumulator housing (57) to remove the 1-2 accumulator piston (56).
2. Remove the 1-2 inner (104) and outer (54) accumulator springs.

1-2 ACCUMULATOR ASSEMBLY

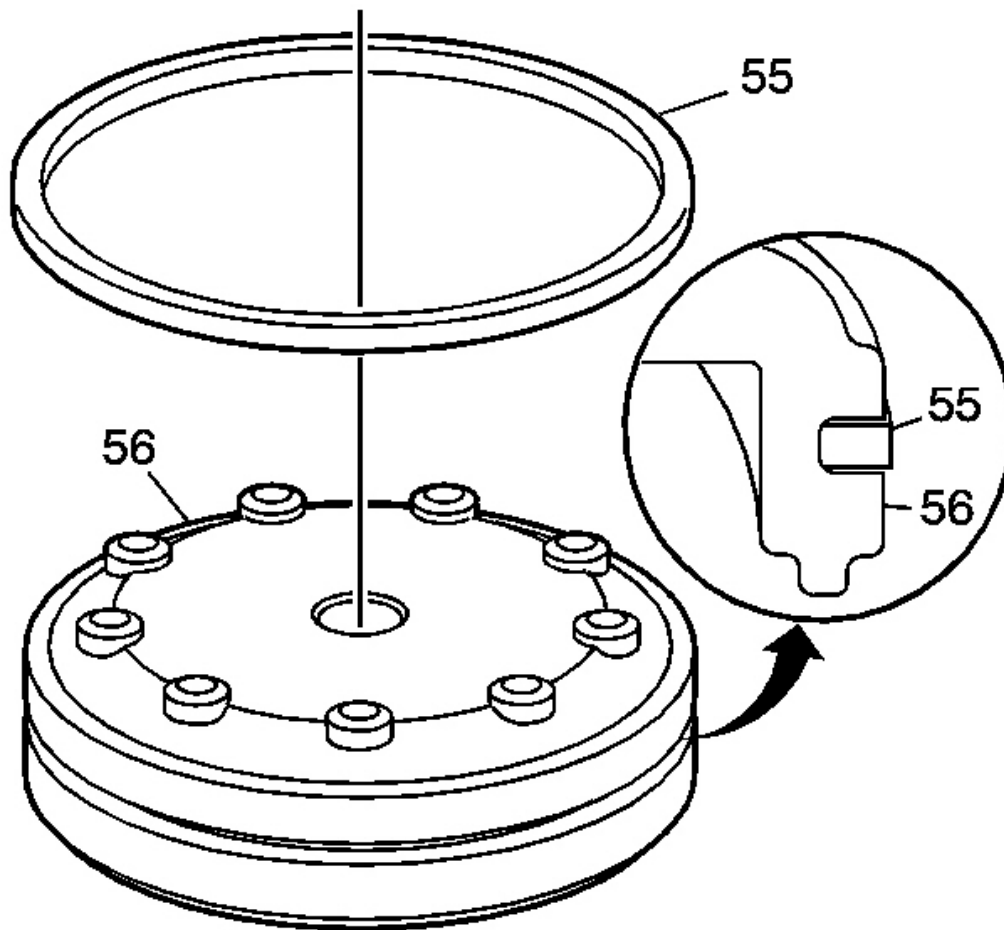

Fig. 439: Locating Accumulator Piston & Oil Seal Ring
Courtesy of GENERAL MOTORS CORP.

1. Inspect the 1-2 accumulator piston (56) for the following conditions:
 - Porosity
 - Cracks
 - Scoring
 - Nicks and Scratches
2. Install a 1-2 accumulator piston oil seal ring (55) on the 1-2 accumulator piston (56).

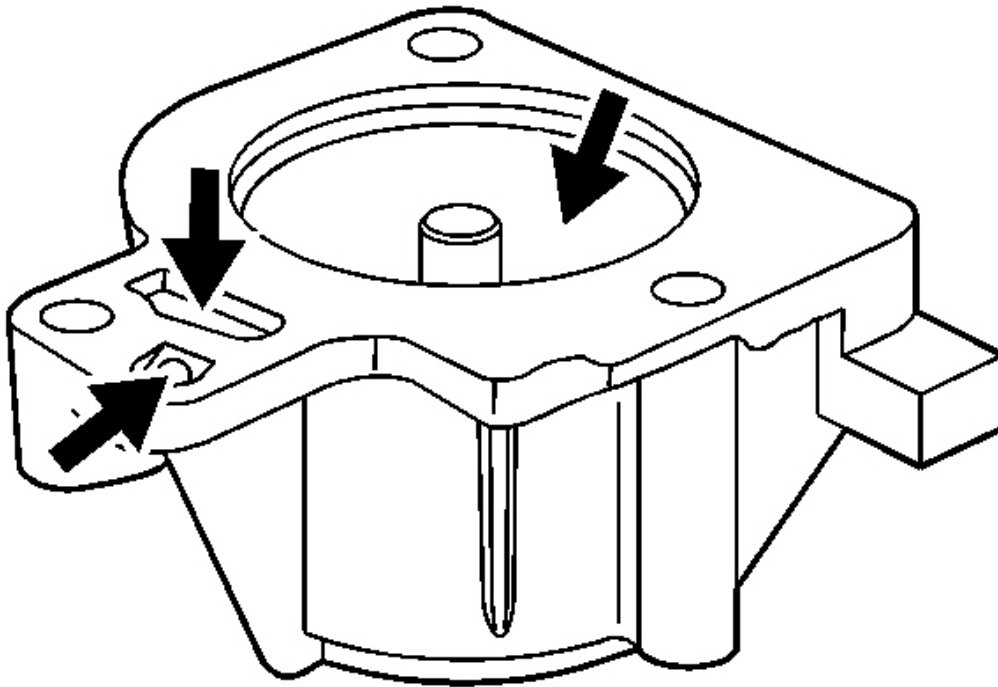

Fig. 440: Locating 1-2 Accumulator Housing Inspection Areas
Courtesy of GENERAL MOTORS CORP.

3. Inspect the 1-2 accumulator housing for the following conditions:
 - Porosity
 - Cracks
 - Scoring
 - Nicks and Scratches
 - Debris or blocked passages

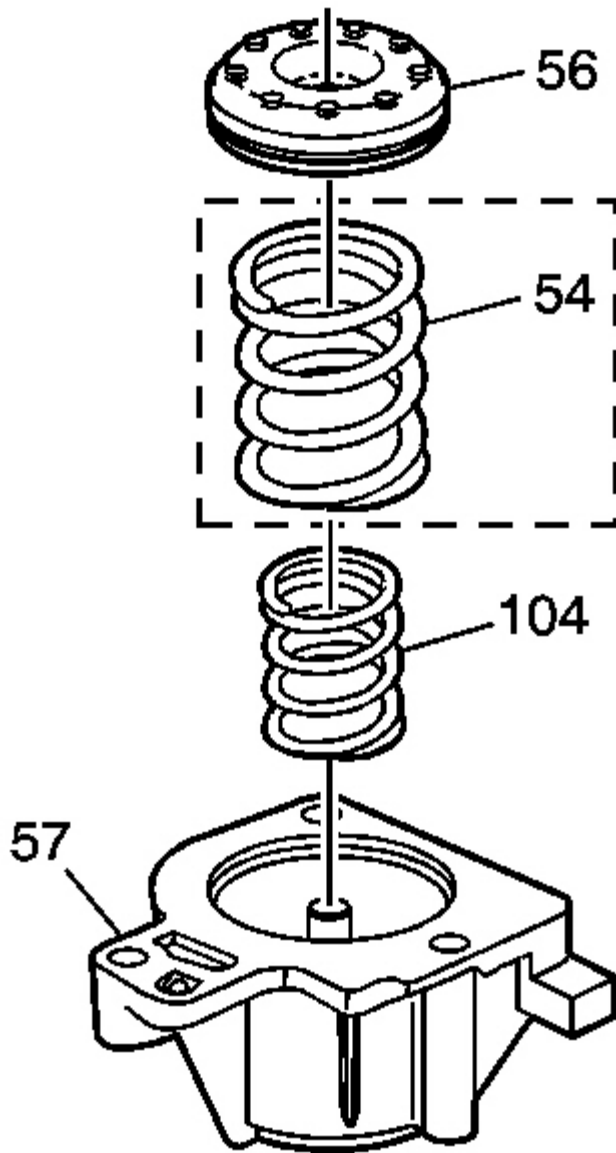

Fig. 441: View Of 1-2 Accumulator Piston, Inner & Outer Accumulator Springs & Housing

Courtesy of GENERAL MOTORS CORP.

IMPORTANT: Some models may not use an outer 1-2 accumulator spring

(54).

4. Install the 1-2 inner (104) and outer (54) accumulator springs.
5. Install the 1-2 accumulator piston (56).

1-2 ACCUMULATOR INSTALLATION

Tools Required

- **J 25025-5** Guide Pins. See **Special Tools**.
- **J 36850** Transjel Lubricant

Installation Procedure

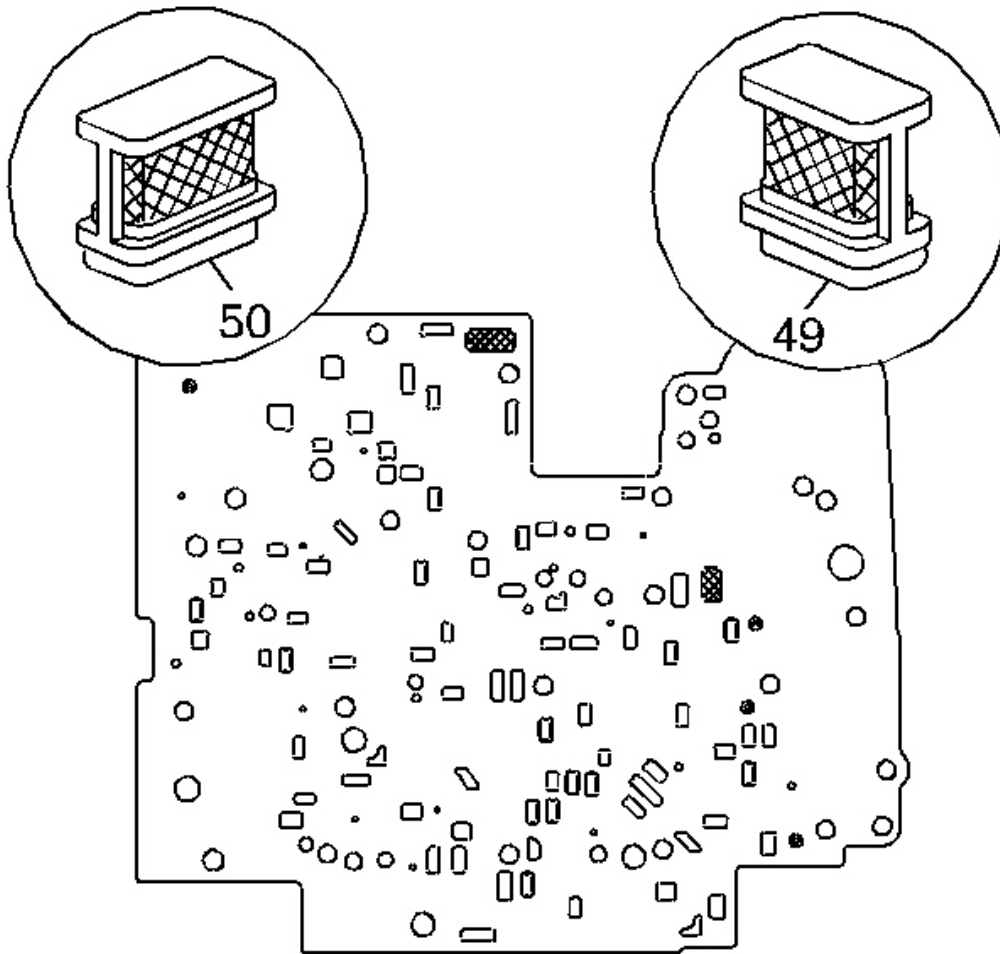

Fig. 442: Identifying Solenoid Screens
Courtesy of GENERAL MOTORS CORP.

1. Inspect the valve body spacer plate and the solenoid screens (49, 50) for damage or debris.
Replace the solenoid screens (49, 50) if necessary.

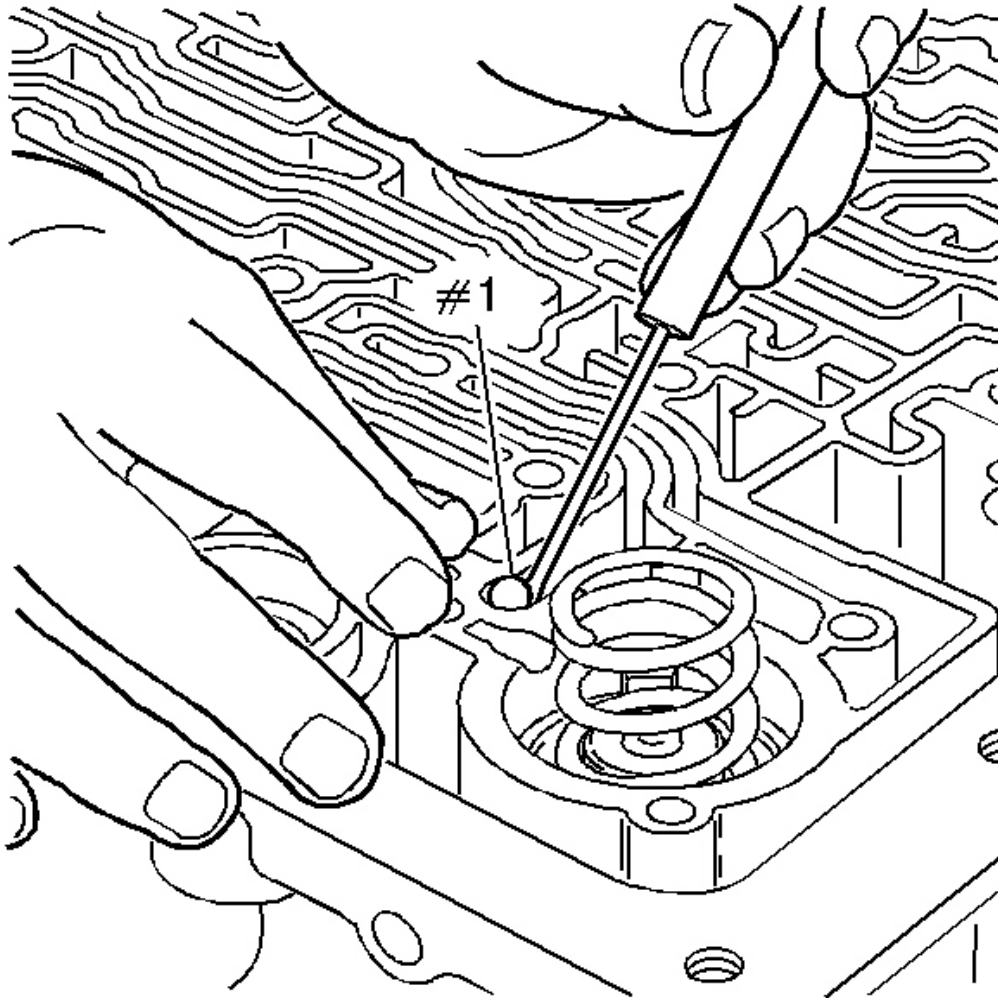

Fig. 443: Locating #1 Checkball
Courtesy of GENERAL MOTORS CORP.

2. Install the #1 checkball into the case.

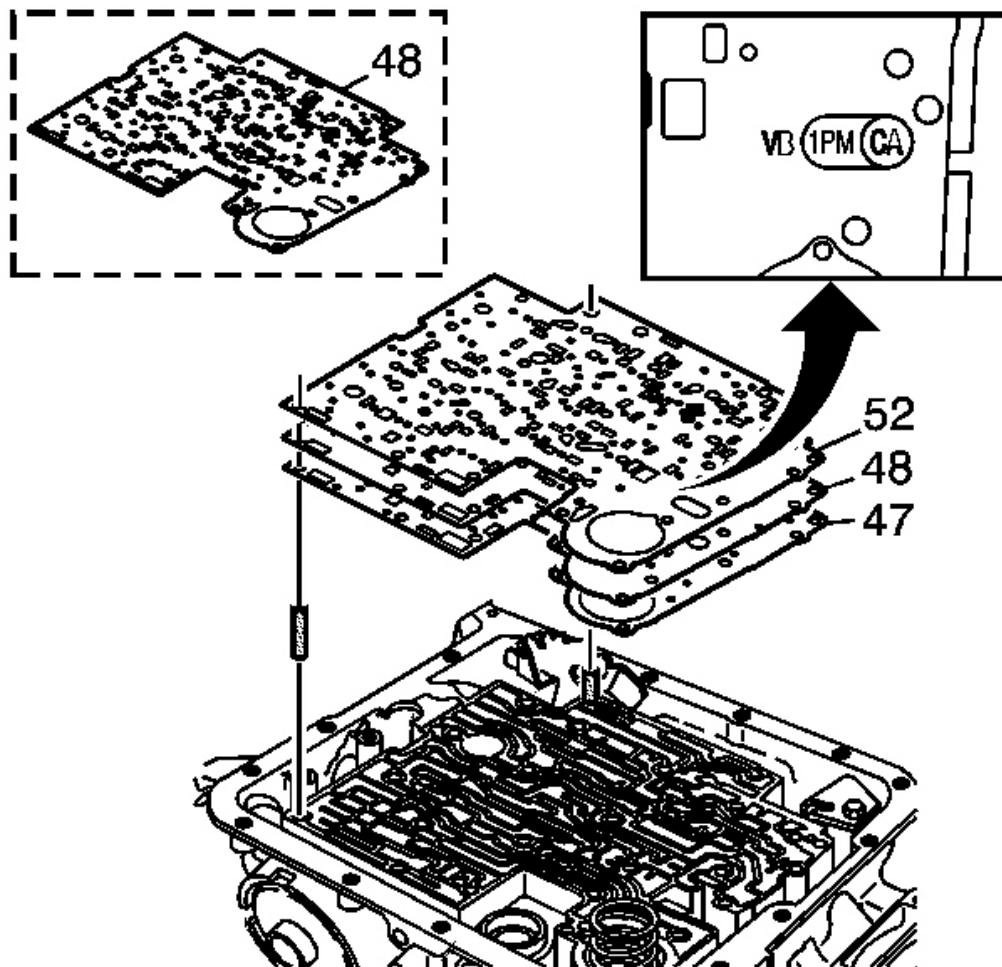

Fig. 444: View Of Valve Body Gasket, Spacer Plate & Case Gasket
 Courtesy of GENERAL MOTORS CORP.

3. Install the **J 25025-5** into the case. See **Special Tools**.

IMPORTANT: Some models use a bonded spacer plate (48). Do not reuse the bonded spacer plate. Replace with a **NEW** bonded spacer plate.

4. Place the spacer plate to case gasket (47) (identified by a "CA") and the spacer plate to valve body gasket (52) (identified by a "VB") on the spacer plate (48). When properly

assembled, all identifiers will be visible and will align. Retain gaskets on the spacer plate with **J 36850** or equivalent.

5. Place the spacer and the spacer plate gaskets on the case.

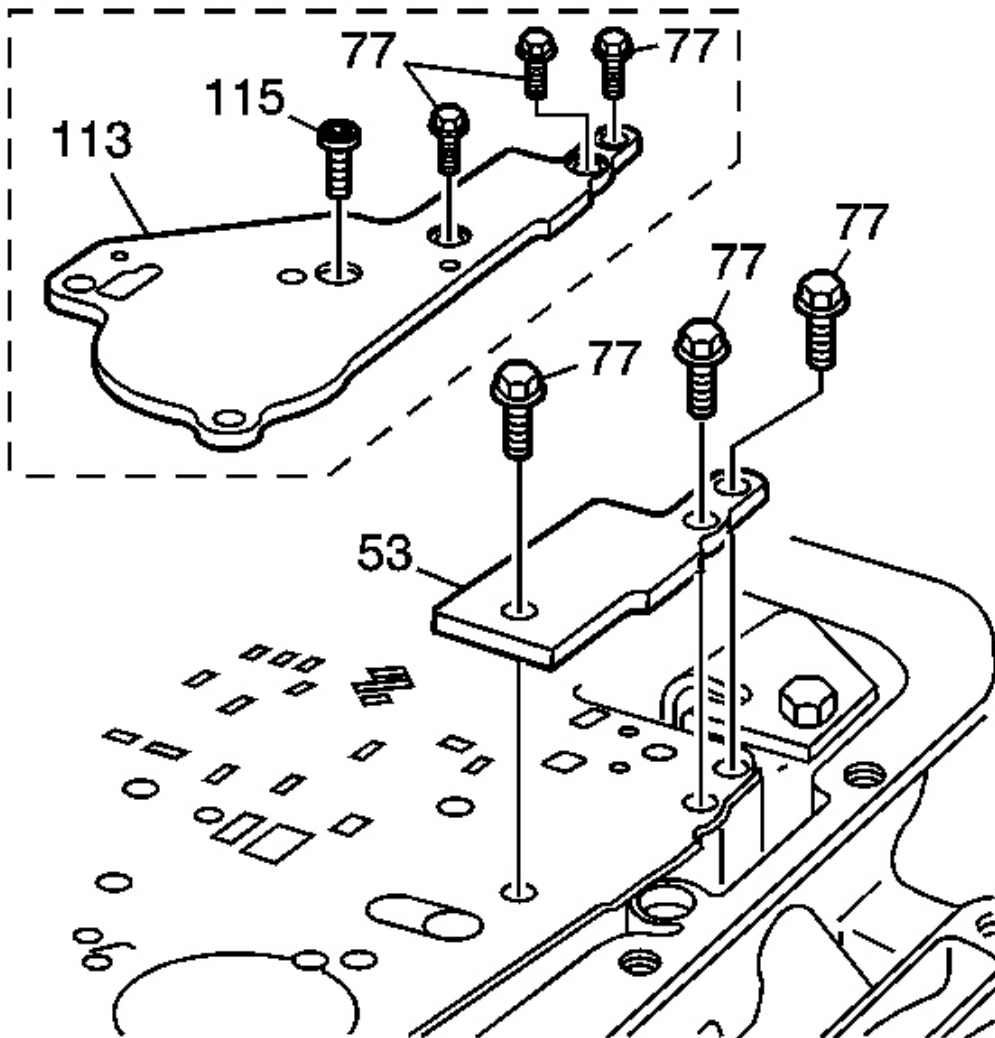

Fig. 445: View Of Spacer Plate Support Plate & Bolts
Courtesy of GENERAL MOTORS CORP.

6. Install the spacer plate support plate (53 or 113).
7. Install the spacer plate support bolts (77).

NOTE: Refer to FASTENER NOTICE .

8. Install the accumulator bolt (115), model dependent.

Tighten: Tighten the accumulator bolt to 11 N.m (8.11 lb ft).

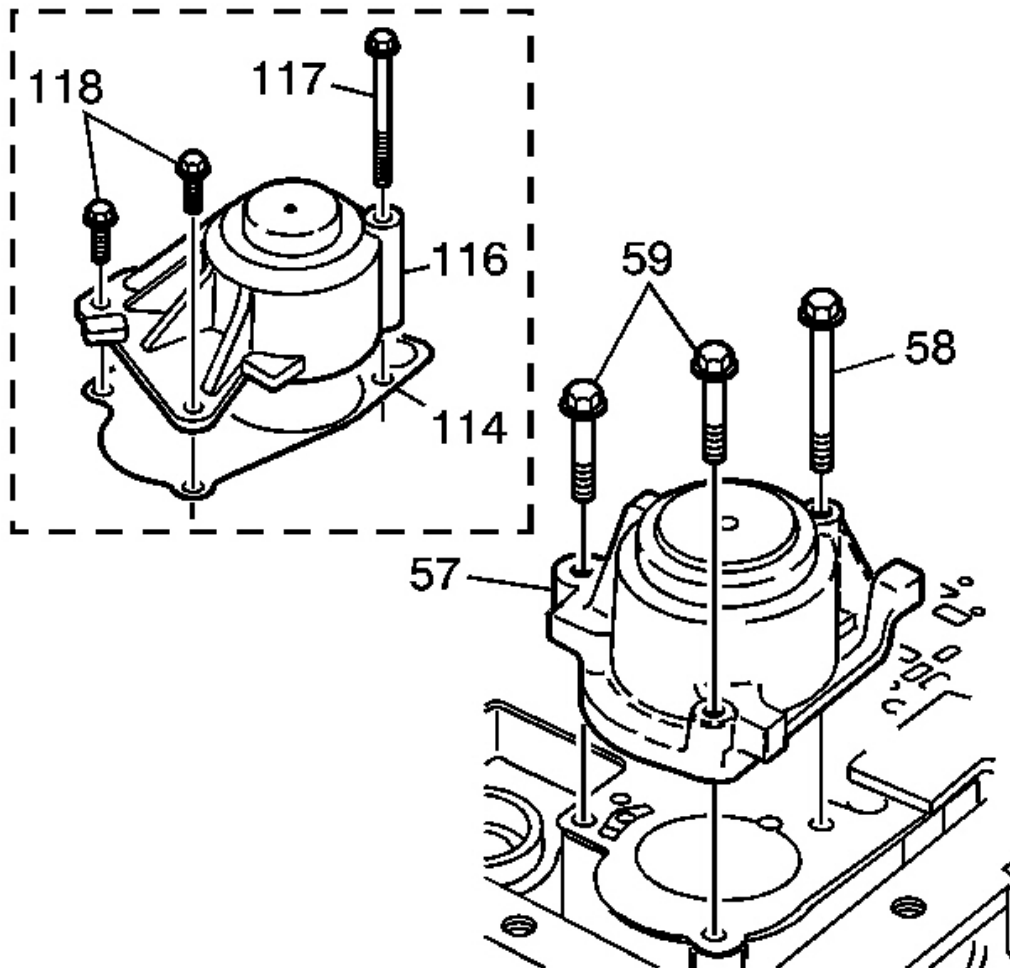

Fig. 446: Installing 1-2 Accumulator Housing Bolts
Courtesy of GENERAL MOTORS CORP.

9. Install the 1-2 accumulator housing assembly (57 or 116).
10. Install the 1-2 accumulator housing bolts (58, 59 or 117, 118).

2007 Hummer H3

2007 TRANSMISSION Automatic Transmission - 4L60-E/4L65-E/4L70-E - H3

Tighten:

- Tighten the bolts 58 and 59 to 11 N.m (8 lb ft).
- Tighten the bolts 117 and 118 to 8-14 N.m (6-10 lb ft).

CONTROL VALVE BODY INSTALLATION

Tools Required

- **J 25025-5** Dial Indicator Mounting Post-M6 x 1. See Special Tools.00
- **J 36850** Transjel Lubricant

Installation Procedure

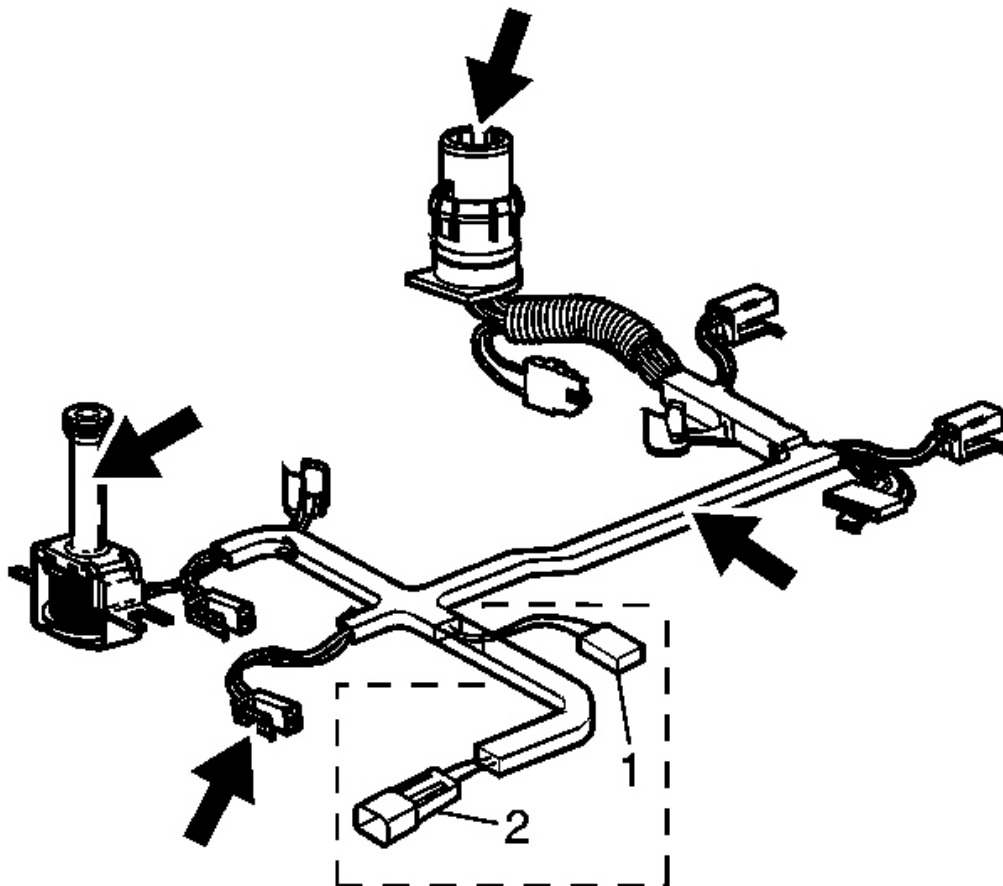

Fig. 447: Identifying Secondary Fluid Pump Connector
Courtesy of GENERAL MOTORS CORP.

IMPORTANT: Secondary fluid pump connector (1) is used for M33 models only, connector (2) is used on ISS models.

1. Inspect the wiring harness and solenoid assembly for the following conditions:
 - Damage
 - Cracked connectors
 - Exposed wires
 - Loose electrical terminals
 - Damaged wiring loom and conduit
 - Worn, missing or cut pass-through connector O-ring seal.
2. Install the transmission wiring harness pass-through connector into the transmission case. Ensure connector tabs lock into place.
3. Move the harness to one side in order to install the valve body.

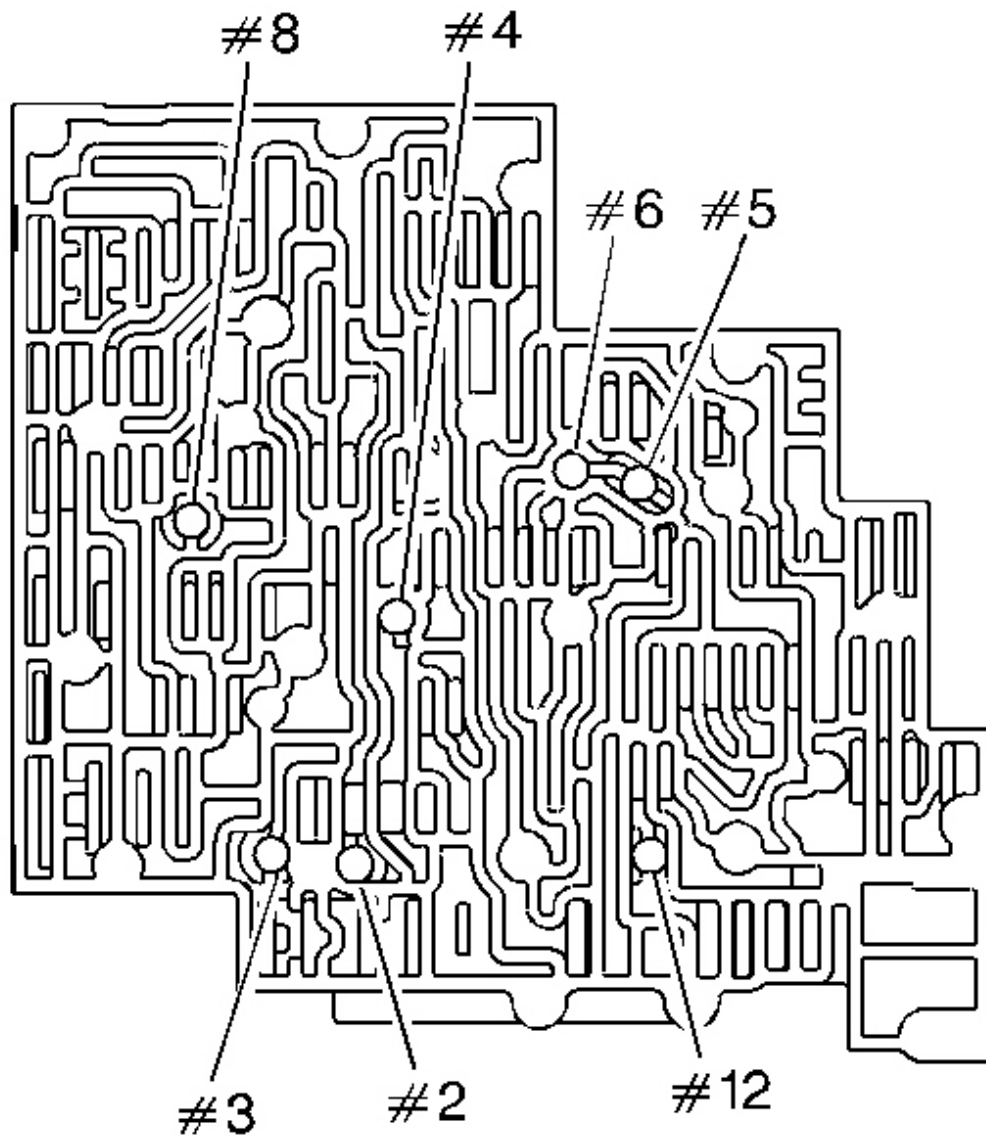

Fig. 448: Identifying Checkball Installation Positions
Courtesy of GENERAL MOTORS CORP.

IMPORTANT: Valve bodies are model dependent.

4. Install the ball check valves (2-6, 8, 12) in the valve body and retain ball check valves with

J 36850 or an equivalent.

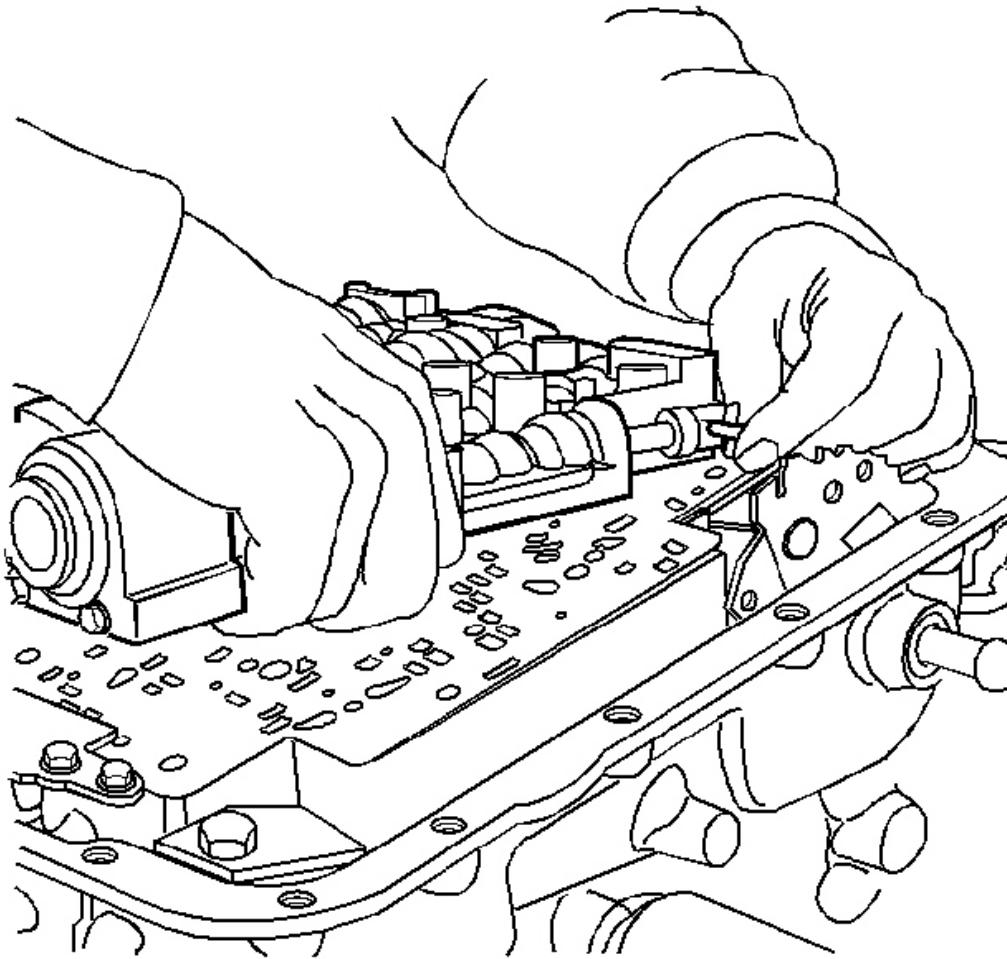

Fig. 449: Installing Valve Body
Courtesy of GENERAL MOTORS CORP.

NOTE: Be sure all solenoids are installed with the electrical connectors facing the non-machined (cast) side of the valve body; otherwise, the solenoids will bind against the transmission case as the valve body bolts are tightened and damage may occur.

5. Install the valve body over the **J 25025-5** and connect the manual valve link to the manual valve. See **Special Tools**.
6. Install 2 valve body bolts to hold the valve body in place.
7. Remove the **J 25025-5** . See **Special Tools**.

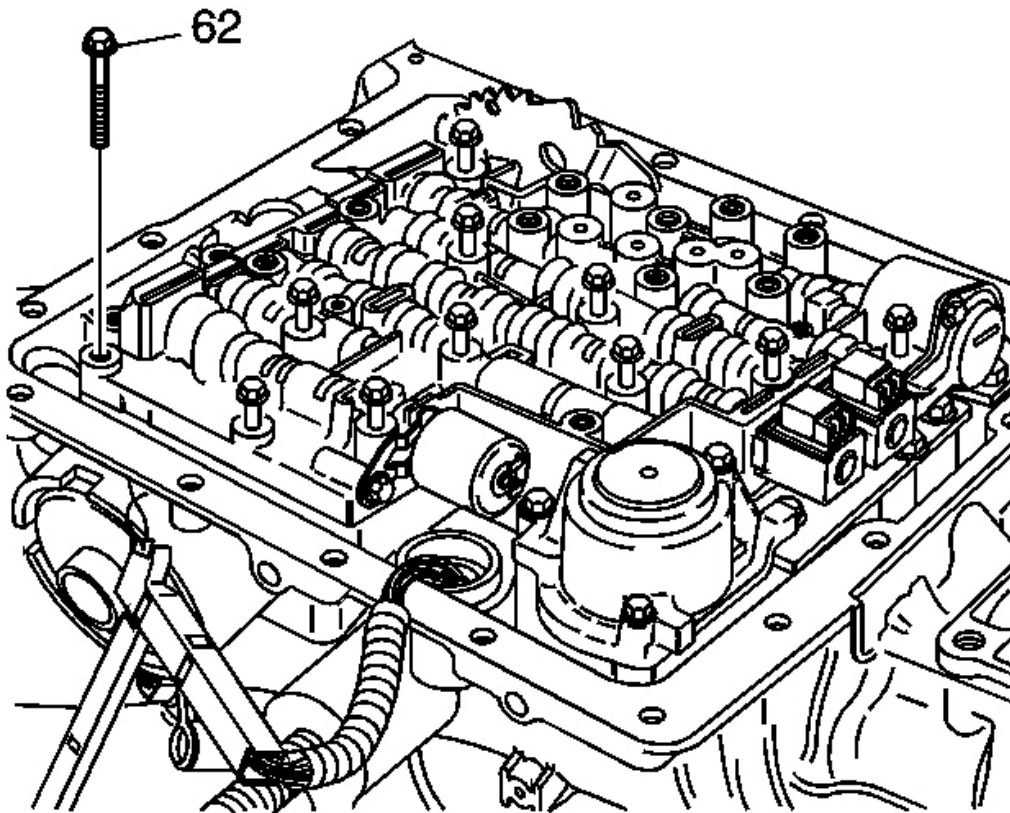

Fig. 450: View Of Valve Body Bolts
Courtesy of GENERAL MOTORS CORP.

8. Install the valve body bolts (62) that are shown only.
9. Finger tighten the bolts.

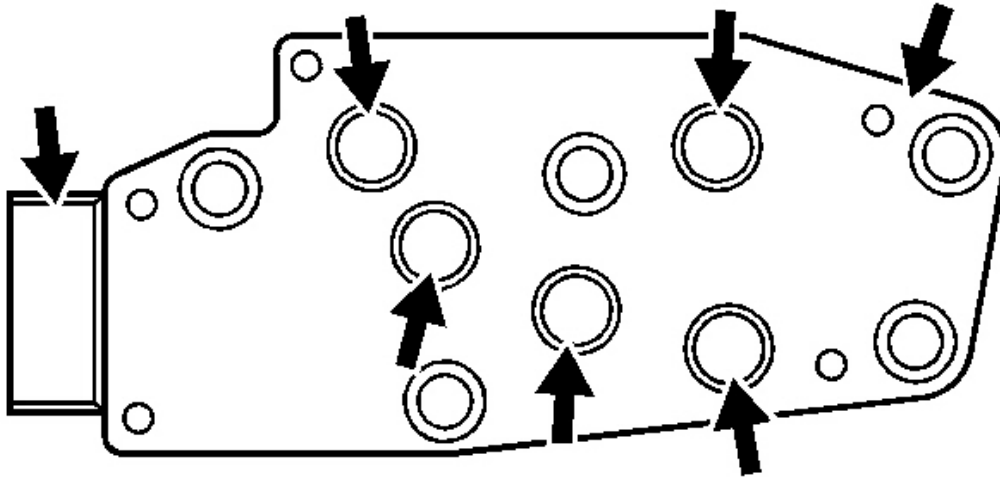

Fig. 451: Inspection Areas On Transmission Fluid Pressure (TFP) Manual Valve Position Switch Assembly
Courtesy of GENERAL MOTORS CORP.

10. Inspect the transmission fluid pressure (TFP) manual valve position switch assembly for the following conditions:
 - Damage
 - Debris
 - Damaged or missing O-rings
 - Cracked connector
 - Loose electrical terminals
 - Poor terminal retention
 - Sediment in switch membrane

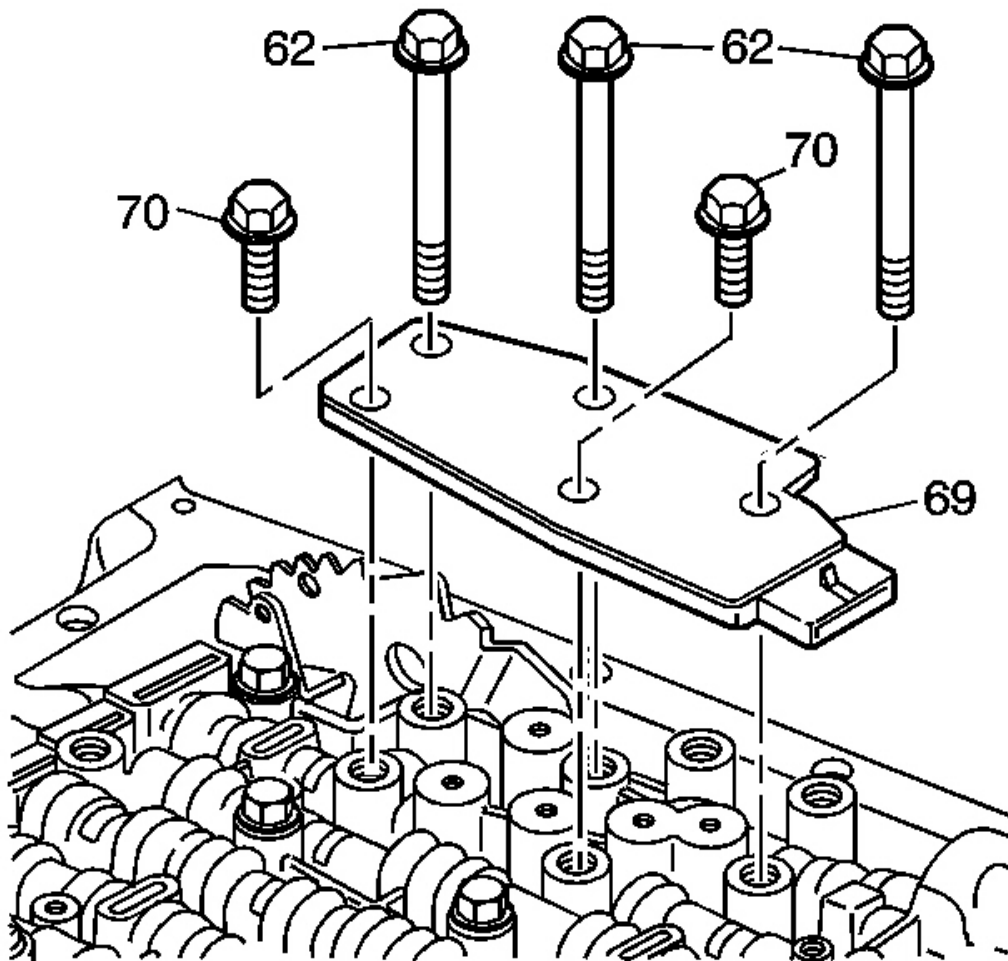

Fig. 452: TFP Manual Valve Position Switch Retaining Bolts
Courtesy of GENERAL MOTORS CORP.

11. Install the TFP manual valve position switch (69) and bolts (62, 70).

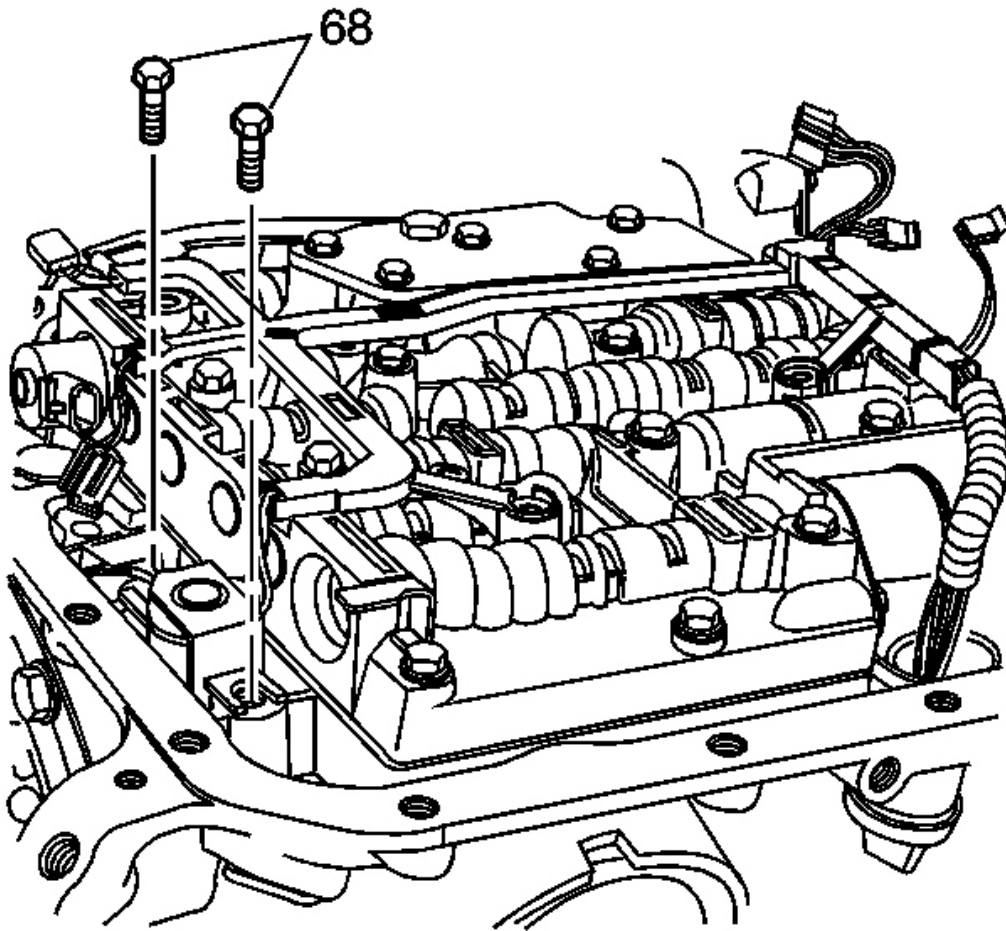

Fig. 453: View Of TCC Solenoid Bolts
Courtesy of GENERAL MOTORS CORP.

12. Install the transmission wiring harness on the valve body.

NOTE: Refer to **FASTENER NOTICE** .

13. Install the torque converter clutch (TCC) solenoid valve and bolts (68).

Tighten: Tighten the bolts to 8-14 N.m (6-10 lb ft).

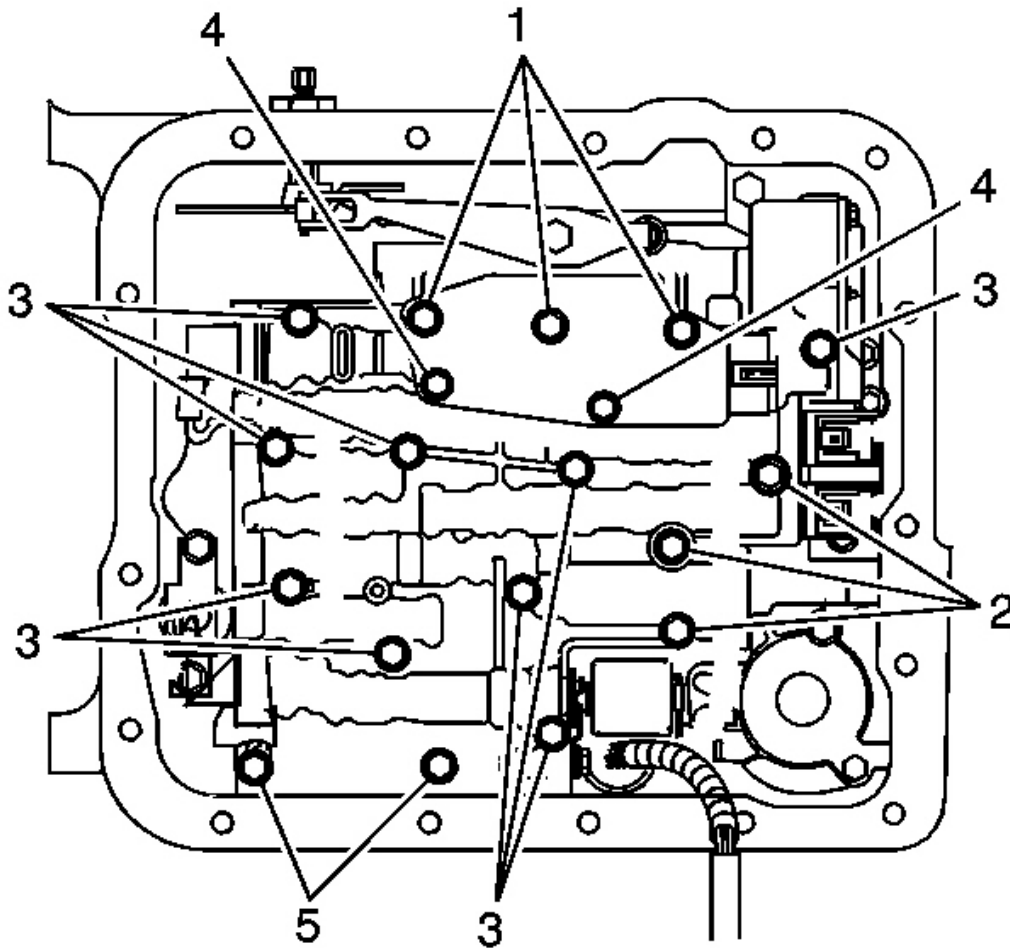

Fig. 454: Locating Valve Body Bolts
 Courtesy of GENERAL MOTORS CORP.

NOTE: Do not over-tighten the bolts. Over-tightening the bolts will distort the valve bores. Begin tightening from the center of the valve body tighten the bolts in a outward direction.

14. Inspect to ensure all of the valve body bolts are in the correct location.

Each bolt number refers to a specific bolt size, as indicated in the following list:

- 1 - M6 x 1.0 x 65.0

- 2 - M6 x 1.0 x 54.4
- 3 - M6 x 1.0 x 47.5
- 4 - M6 x 1.0 x 17.7
- 5 - M6 x 1.0 x 35.0

15. Tighten the bolts from the center of the valve body working your way out in a spiral pattern to the outside edge.

Tighten: Tighten the bolts to 8-14 N.m (6-10 lb ft).

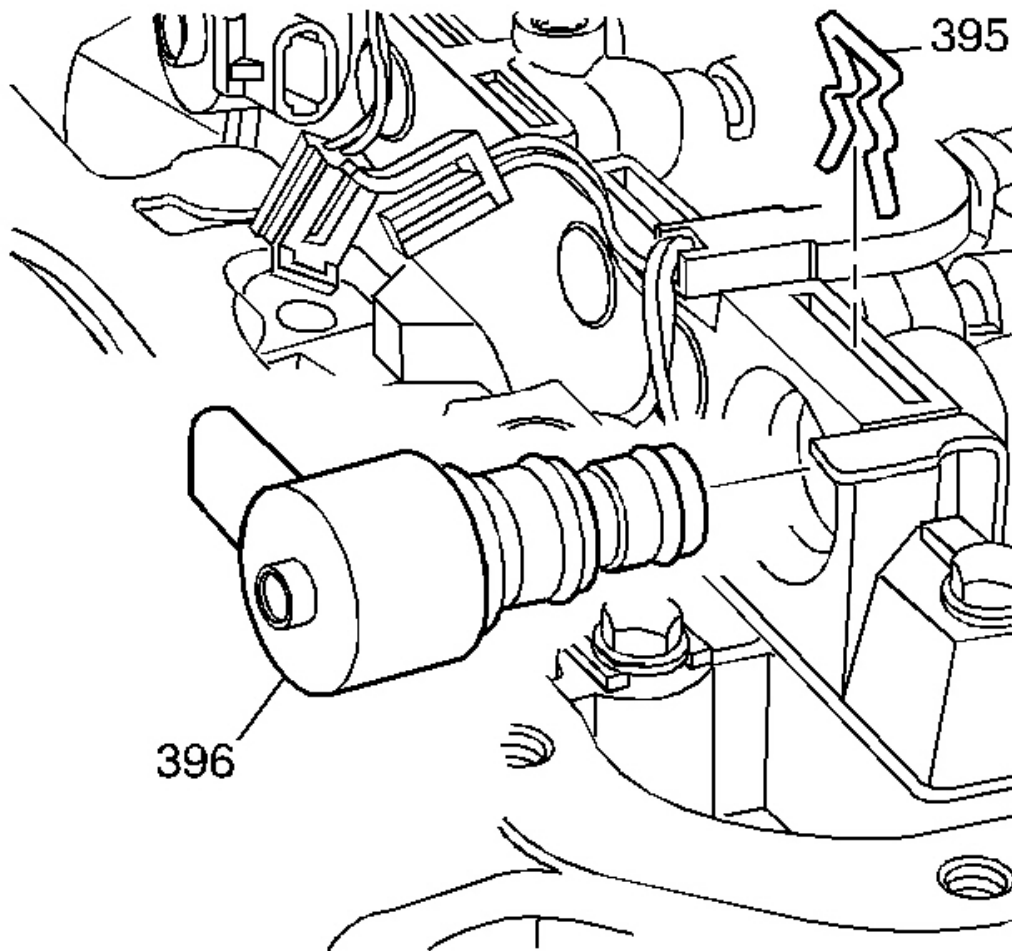

Fig. 455: Removing TCC/PWM Solenoid & Clip
Courtesy of GENERAL MOTORS CORP.

16. Install the torque converter clutch pulse width modulation (TCC PWM) solenoid valve (396) and the solenoid retainer (395).

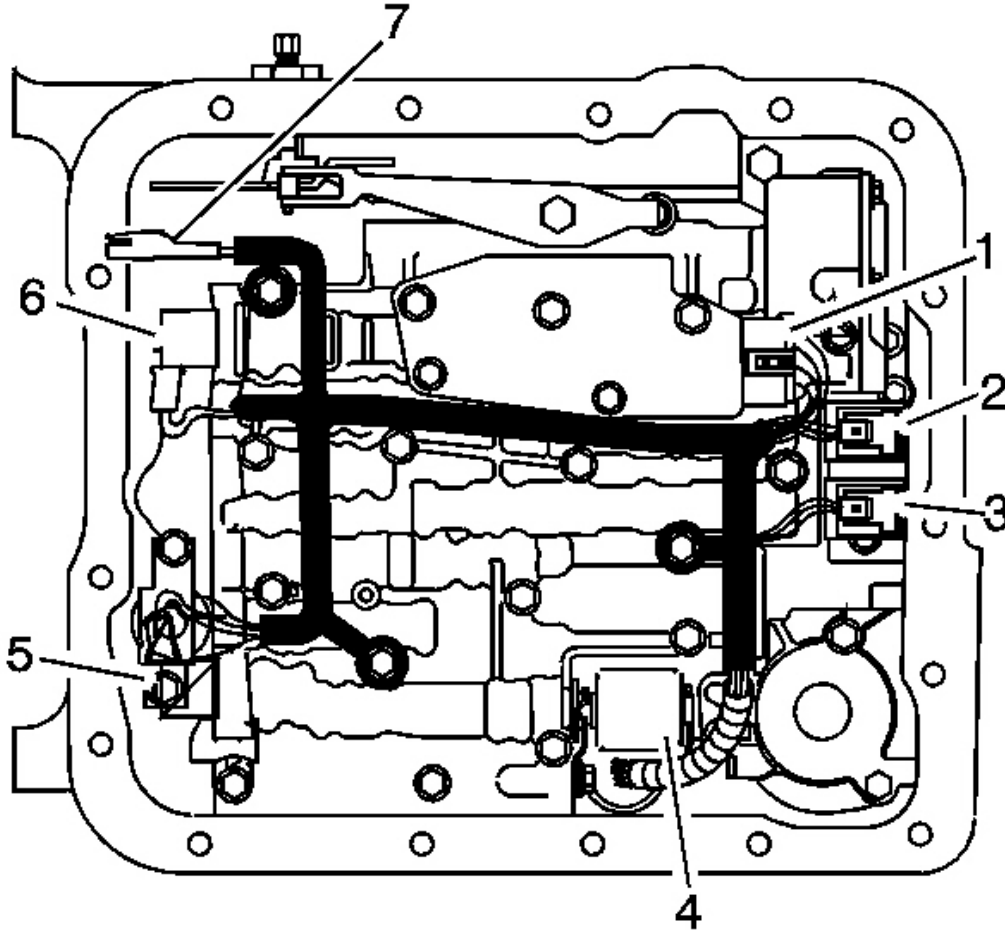

Fig. 456: Snapping Wiring Harness On Valve Body Bolts
Courtesy of GENERAL MOTORS CORP.

17. Snap the wiring harness in place on the valve body bolts. Ensure the harness loom tab is located under the TFP switch.
18. Install the wiring connectors to the electrical components as indicated in the following list:
 - 1 - TFP manual valve position switch
 - 2 - 1-2 shift solenoid

- 3 - 2-3 shift solenoid
- 4 - pressure control solenoid (PCS)
- 5 - TCC PWM solenoid
- 6 - 3-2 shift solenoid
- 7 - input speed sensor (ISS) - model dependent

MANUAL DETENT SPRING INSTALLATION

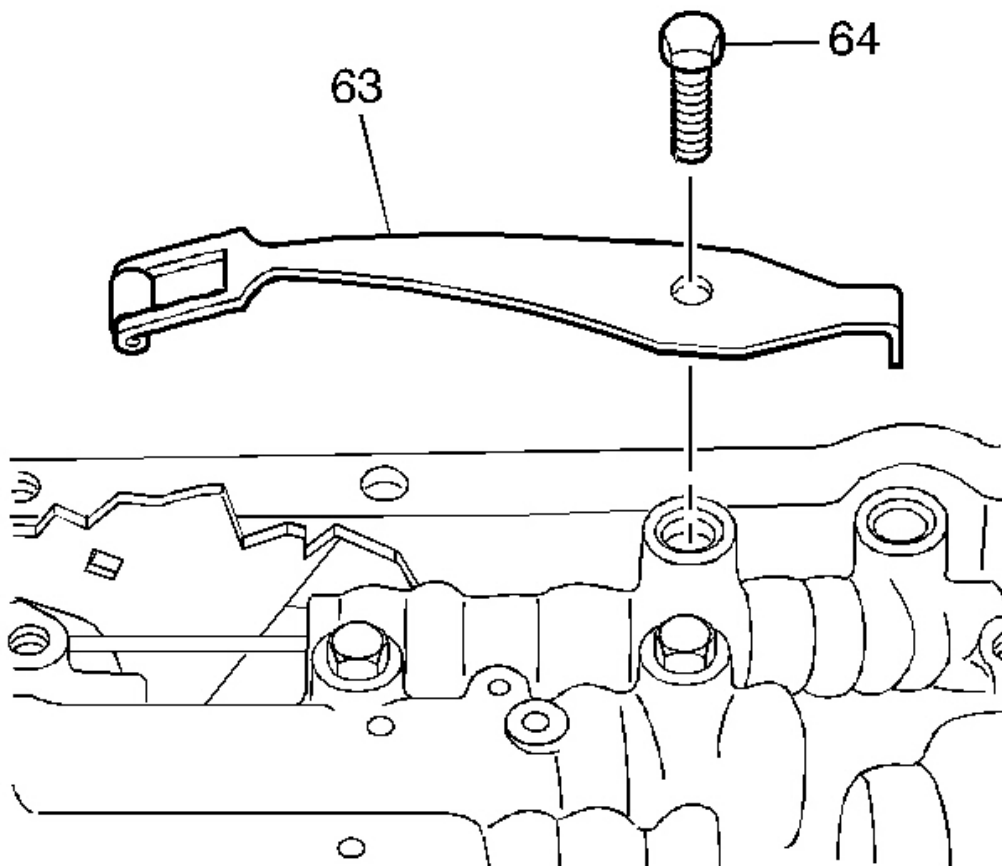

Fig. 457: View Of Manual Detent Spring Assembly
Courtesy of GENERAL MOTORS CORP.

1. Inspect the manual detent spring assembly (63) for cracks or damage.
2. Install the manual detent spring assembly (63).

NOTE: Refer to FASTENER NOTICE .

3. Install the manual detent spring bolt (64).

Tighten: Tighten the bolt to 20-27 N.m (15-20 lb ft).

OIL FILTER ASSEMBLY INSTALLATION

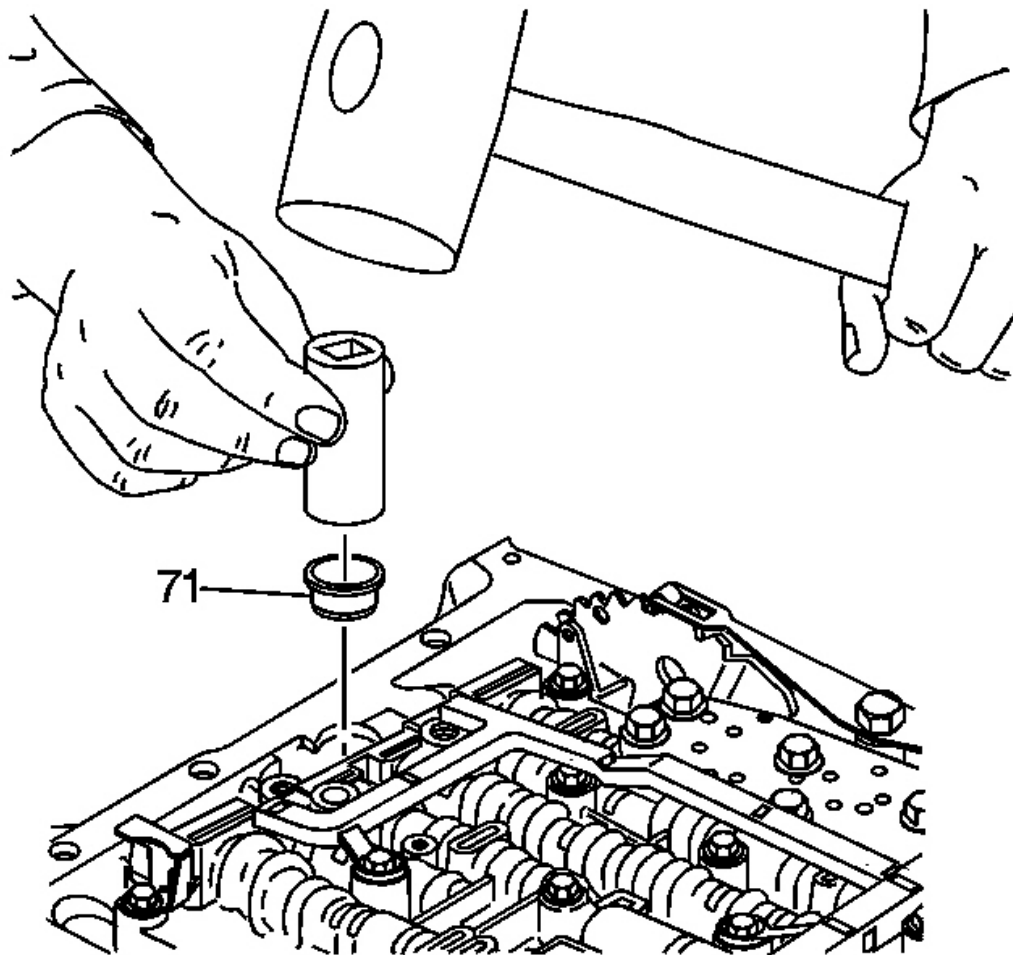

Fig. 458: Locating Oil Filter Seal
Courtesy of GENERAL MOTORS CORP.

1. Lubricate the filter seal (71) with transmission fluid.

2. Use a socket the same size diameter as the filter seal (71) and install the seal.

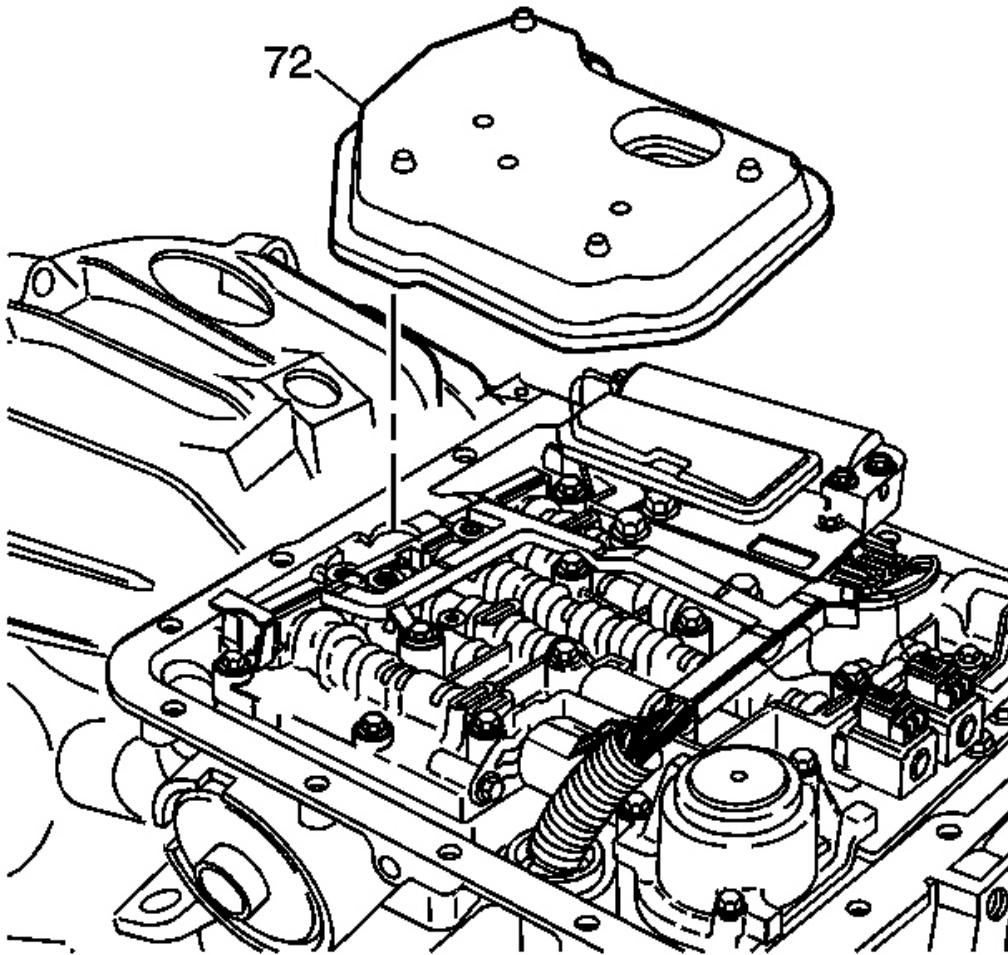

Fig. 459: View Of Transmission Oil Filter Assembly
Courtesy of GENERAL MOTORS CORP.

3. Install the transmission oil filter assembly (72).

TRANSMISSION FLUID PAN INSTALLATION

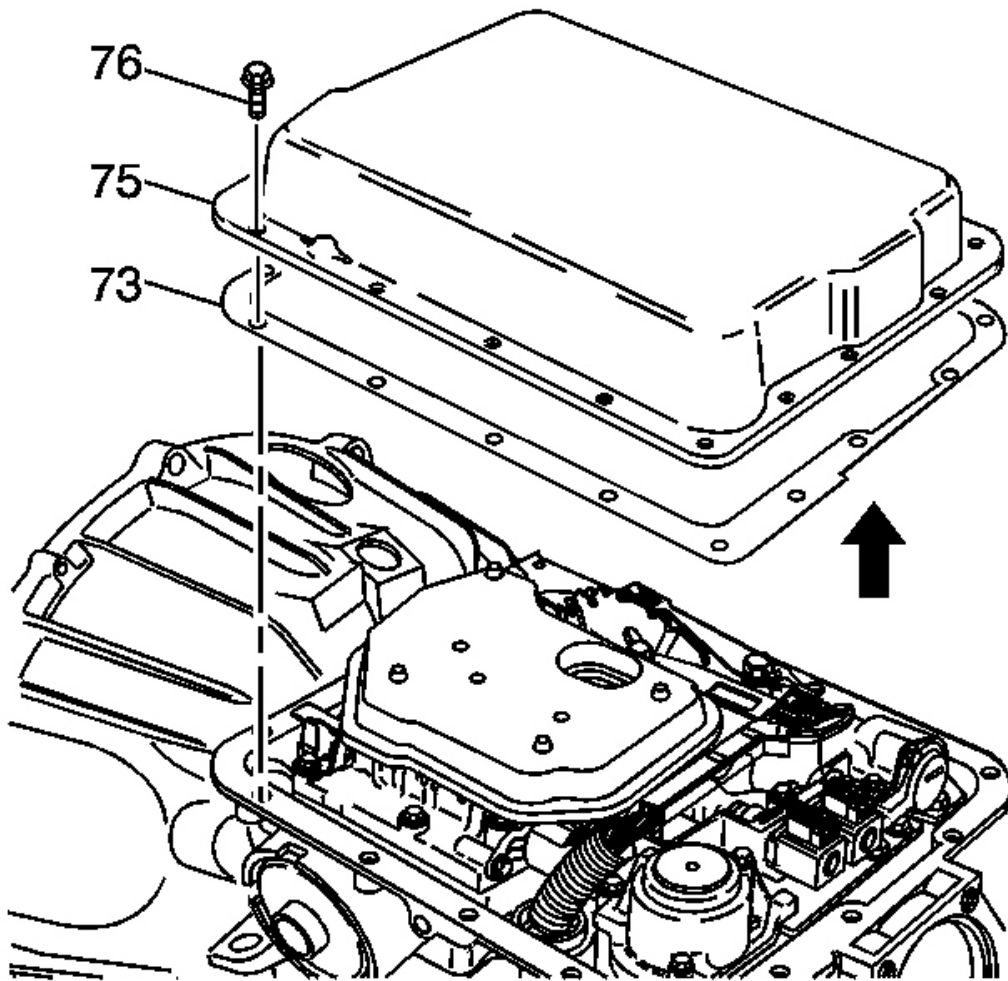

Fig. 460: View Of Transmission Oil Pan & Gasket
Courtesy of GENERAL MOTORS CORP.

1. Place the transmission oil pan gasket (73) on the case.
2. Place the transmission oil pan (75) on the case.

NOTE: Refer to **FASTENER NOTICE** .

3. Install all of the transmission oil pan screws (76).

Tighten: Tighten the screws to 16 N.m (11.8 lb ft).

2-4 SERVO DISASSEMBLE**Tools Required**

J 22269-01 Accumulator and Servo Piston Remover. See **Special Tools**.

Disassembly Procedure

Fig. 461: Locating Servo Cushion Outer & Inner Spring With Retainer
Courtesy of GENERAL MOTORS CORP.

1. Use a **J 22269-01** to compress the second apply piston assembly (17). See **Special Tools**.

2. Remove the second apply piston retaining ring (14).
3. Remove the servo cushion spring retainer (15), the servo cushion outer spring (16) and the servo cushion inner spring (105) (model dependent).

2-4 SERVO PIN LENGTH CHECK

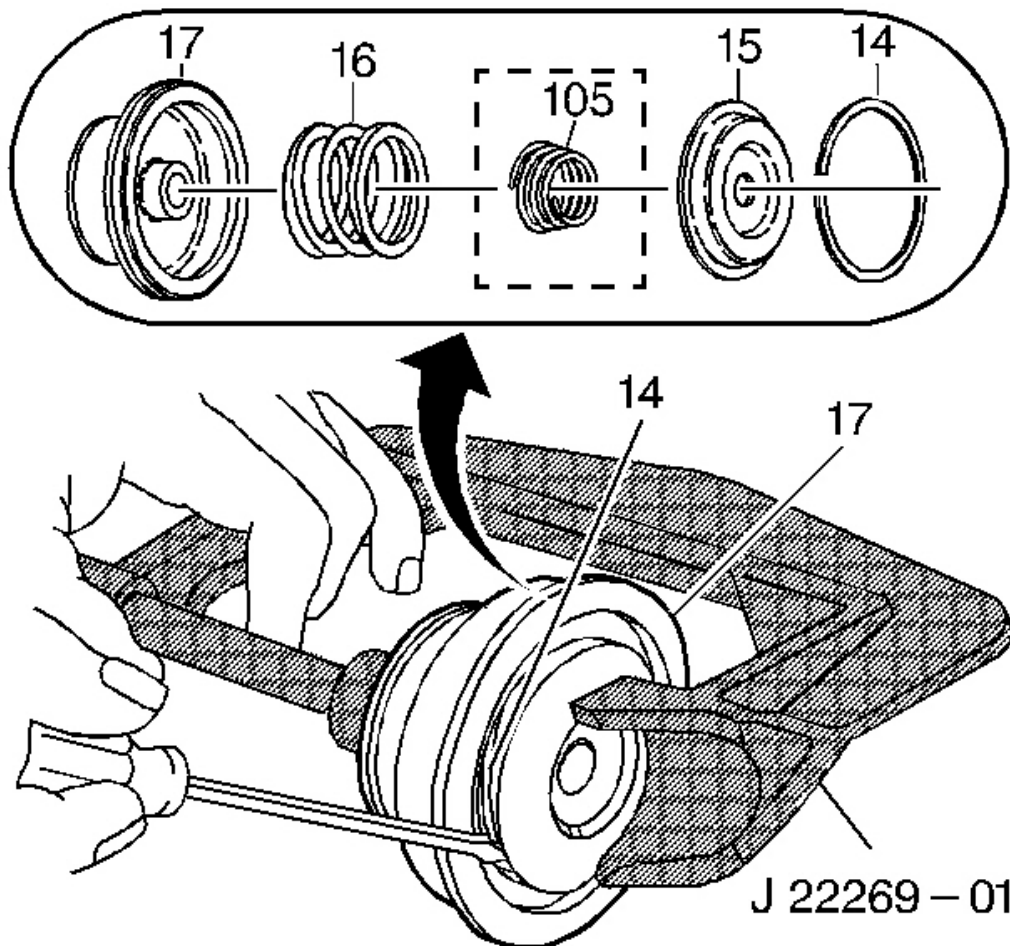
Tools Required

J 33037 2-4 Intermediate Band Apply Pin Gage. See **Special Tools**.

Check Procedure

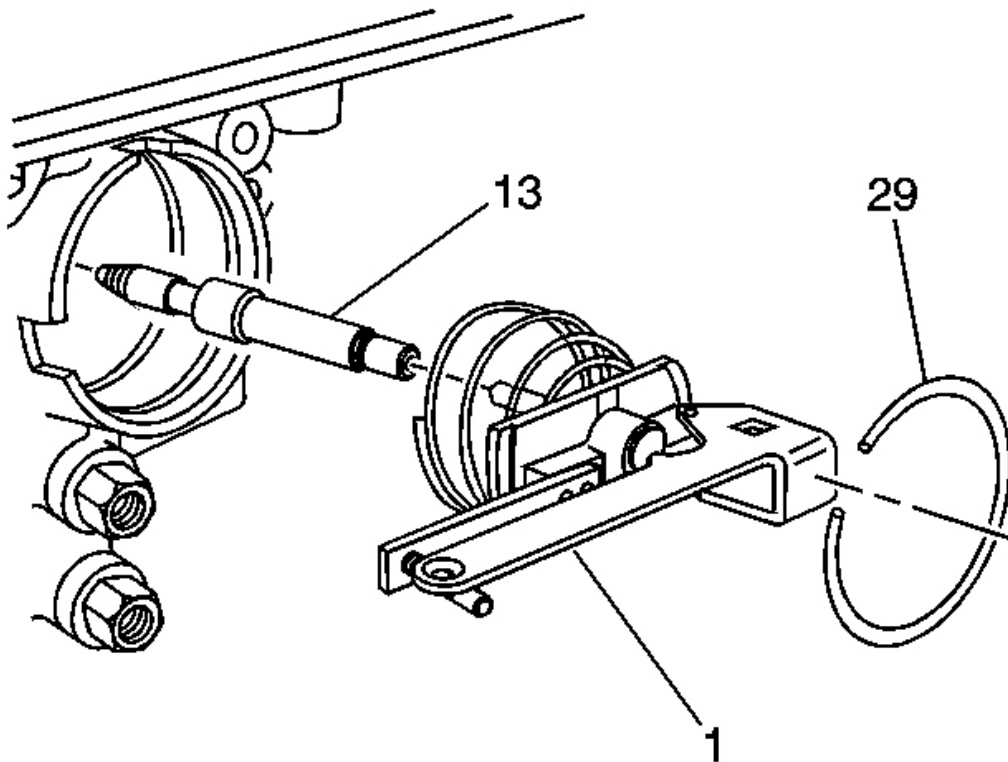

Fig. 462: Locating Servo Cover Retaining Ring
Courtesy of GENERAL MOTORS CORP.

1. Install the band apply pin (13) and the **J 33037** . See **Special Tools**.
2. Install the servo cover retaining ring (29) to secure the tool.

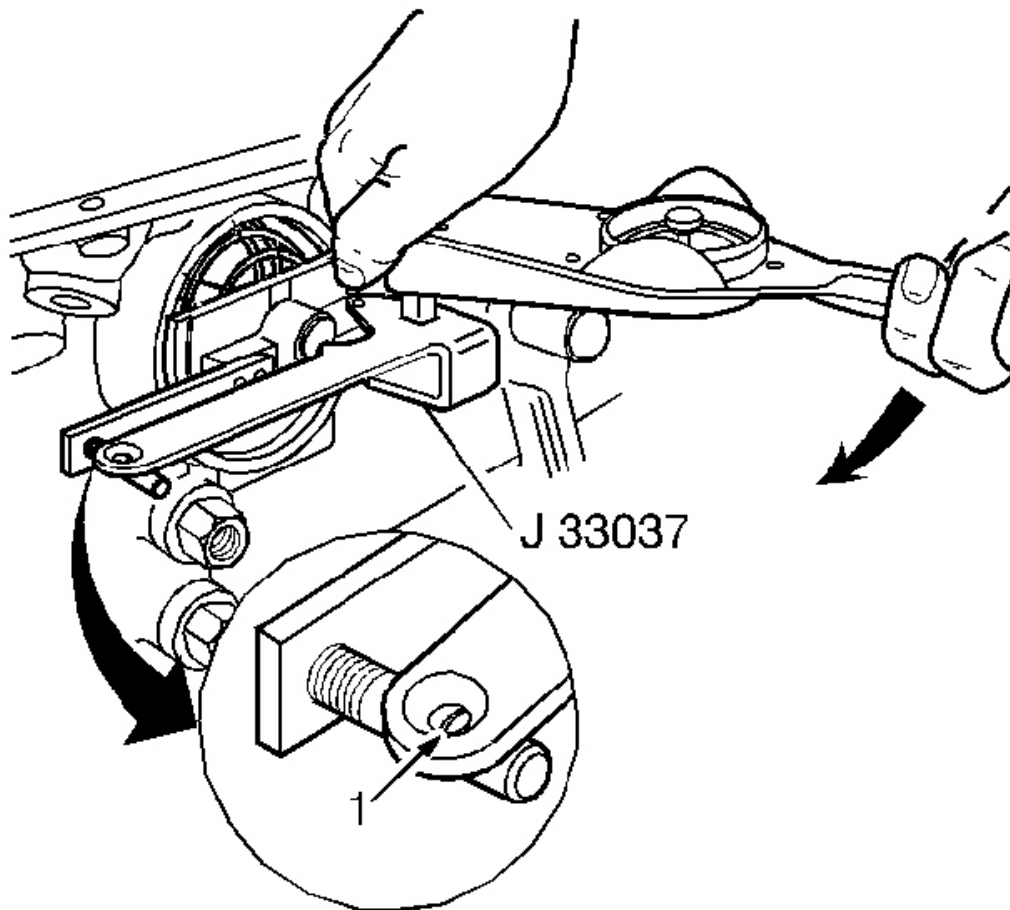

Fig. 463: Identifying Gage Slot
Courtesy of GENERAL MOTORS CORP.

3. Apply 11 N.m (98 lb in) torque. If the white line appears in the gage slot (1), the pin length is correct.
4. If a new pin is needed, refer to **2-4 Servo Pin Selection** in order to determine the correct pin length.

2-4 SERVO ASSEMBLY INSTALLATION

Tools Required

- **J 22269-01** Accumulator and Servo Piston Remover. See **Special Tools**.

- **J 29714-A** Servo Cover Depressor. See Special Tools.

Installation Procedure

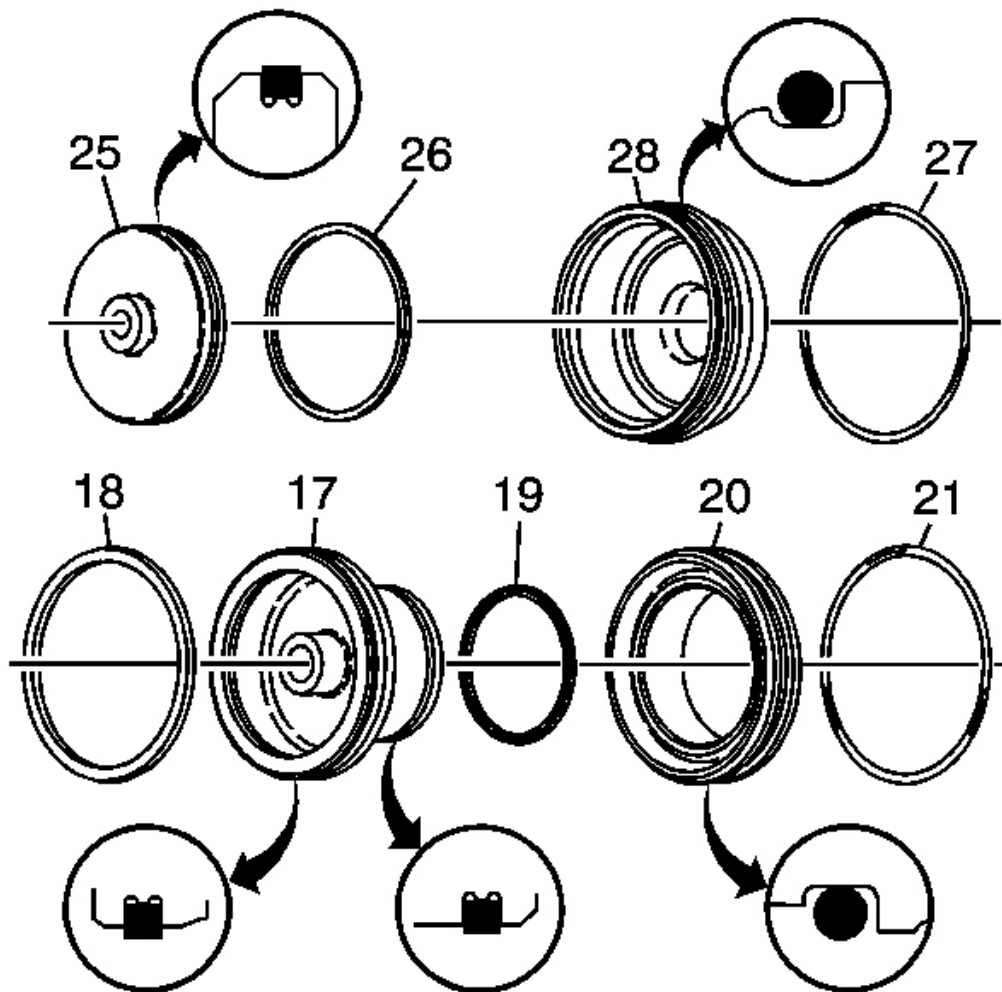

Fig. 464: View Of 4th Apply Piston, 2-4 Servo Cover, 2nd Apply Piston, & Servo Piston Inner Housing
 Courtesy of GENERAL MOTORS CORP.

1. Inspect the 4th apply piston (25), the 2-4 servo cover (28), the 2nd apply piston (17) and the servo piston inner housing (20) for the following conditions:
 - Cracks

- Scoring
 - Burrs and nicks
2. Install the following seals:
- The 4th apply piston outer oil seal ring (26) on the 4th apply piston (25).
 - The 2-4 servo cover O-ring seal (27) on the 2-4 servo cover (28).
 - The 2nd apply piston outer (18) and inner (19) oil seal rings on the 2nd apply piston (17).
 - The O-ring seal (21) on the servo piston inner housing (20).

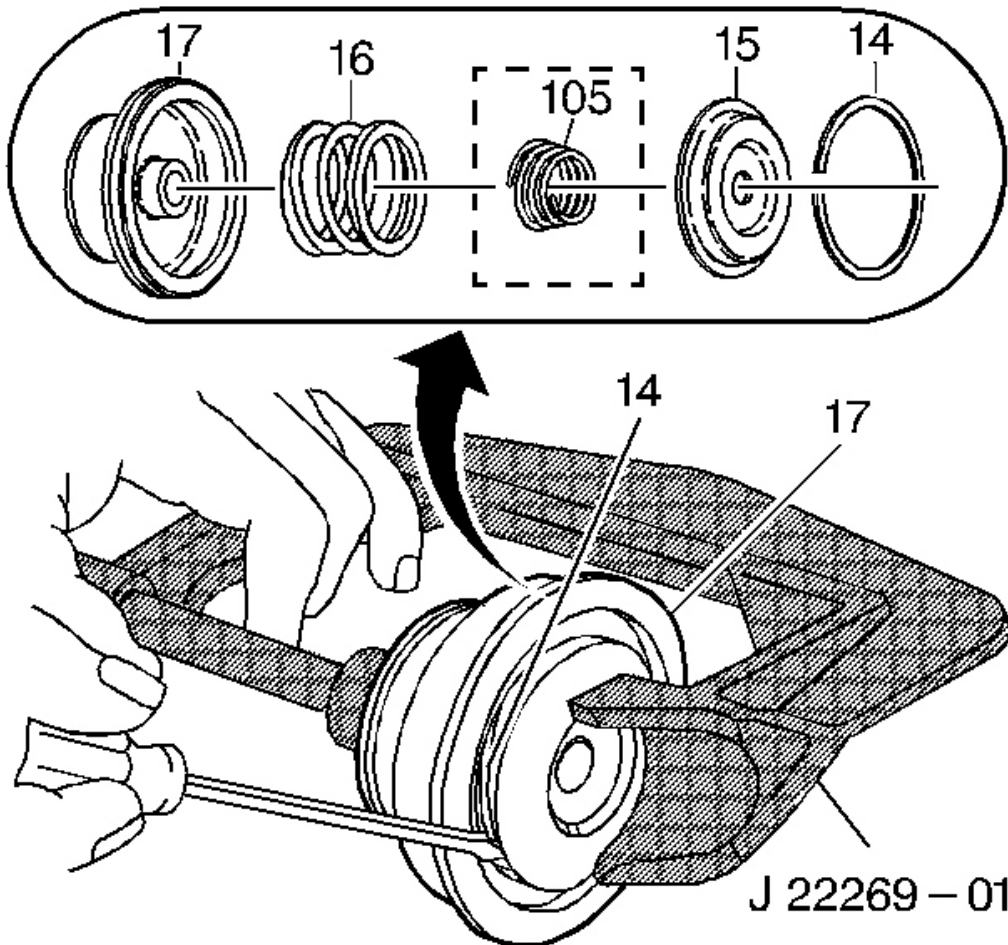

Fig. 465: Locating Servo Cushion Outer & Inner Spring With Retainer

Courtesy of GENERAL MOTORS CORP.

3. Install the servo cushion outer spring (16), the servo cushion inner spring (105) (model dependent) and the cushion spring retainer (15) in the 2nd apply piston (17).
4. Use the **J 22269-01** and compress the second apply piston assembly (17). See **Special Tools**.
5. Install the second apply piston retaining ring (14).

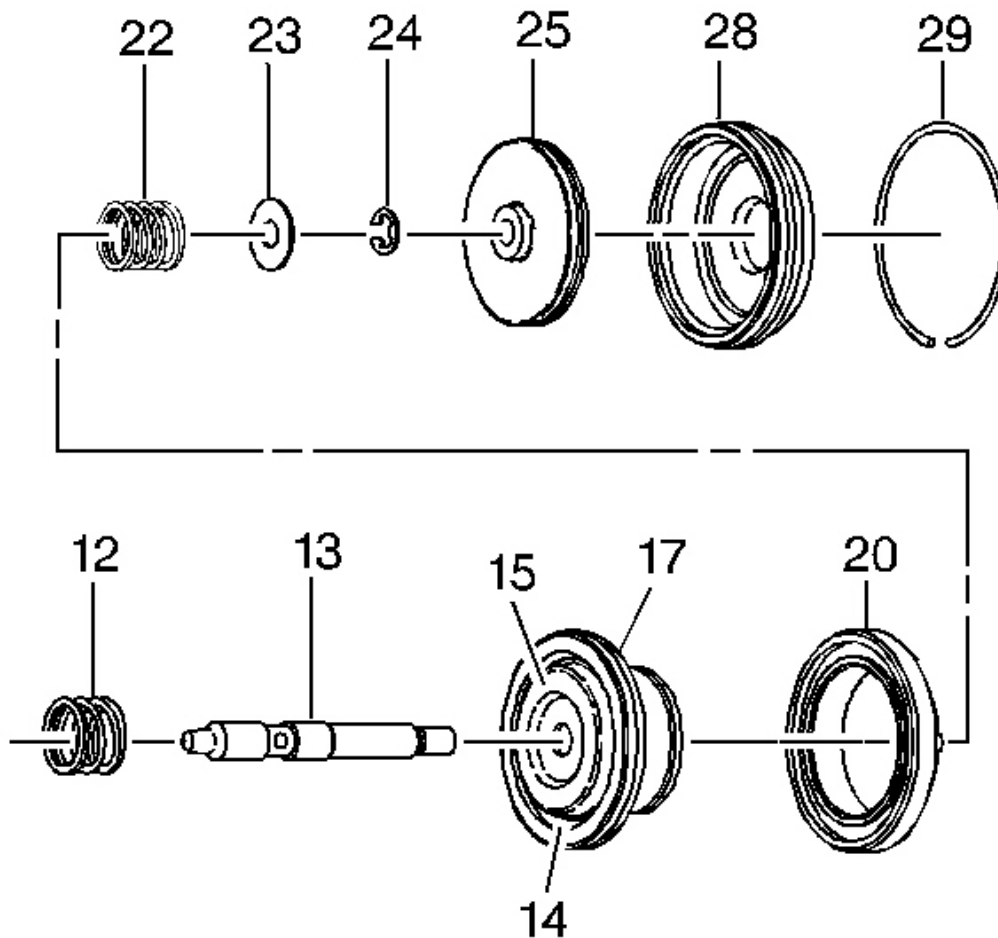

Fig. 466: Illustrating Assembly Order Of 2-4 servo components
Courtesy of GENERAL MOTORS CORP.

6. Assemble the 2-4 servo components in the order shown: (12-15, 17, 20, 22-25, 28, 29).

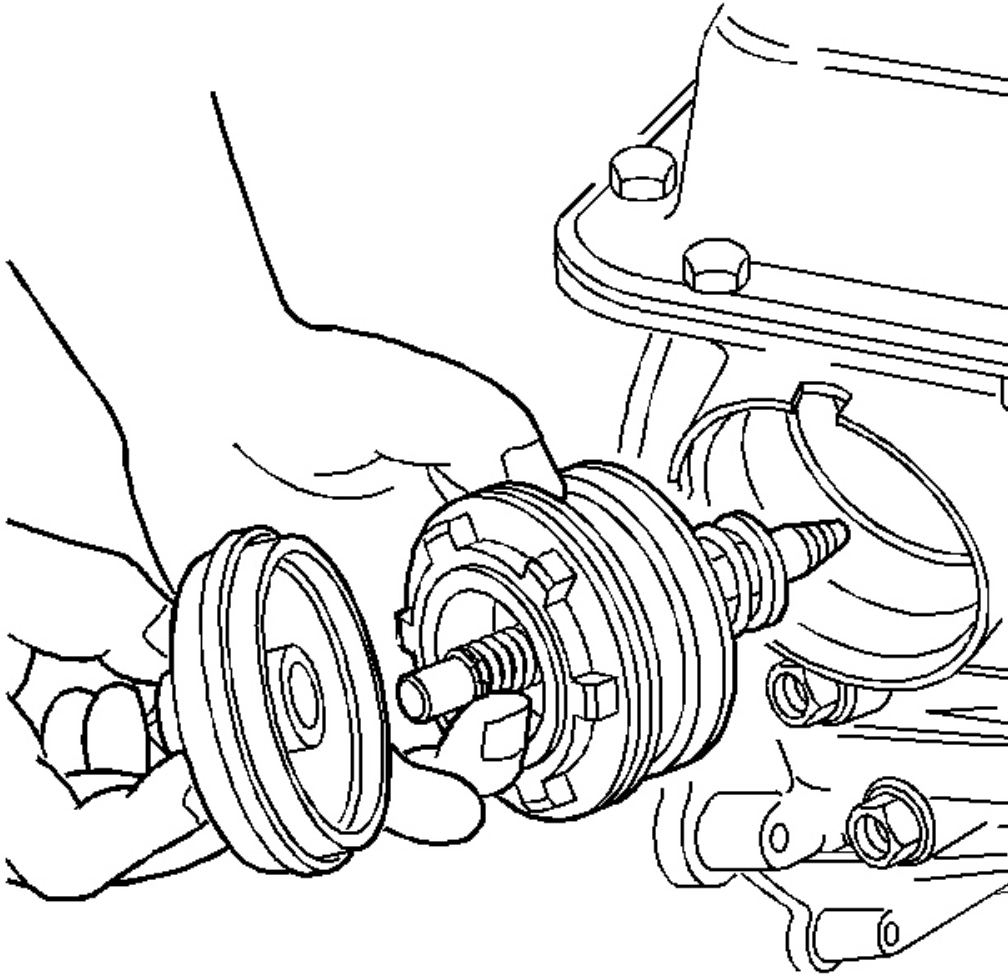

Fig. 467: View Of 2-4 Servo
Courtesy of GENERAL MOTORS CORP.

7. Install the 2-4 servo assembly into the 2-4 servo bore.

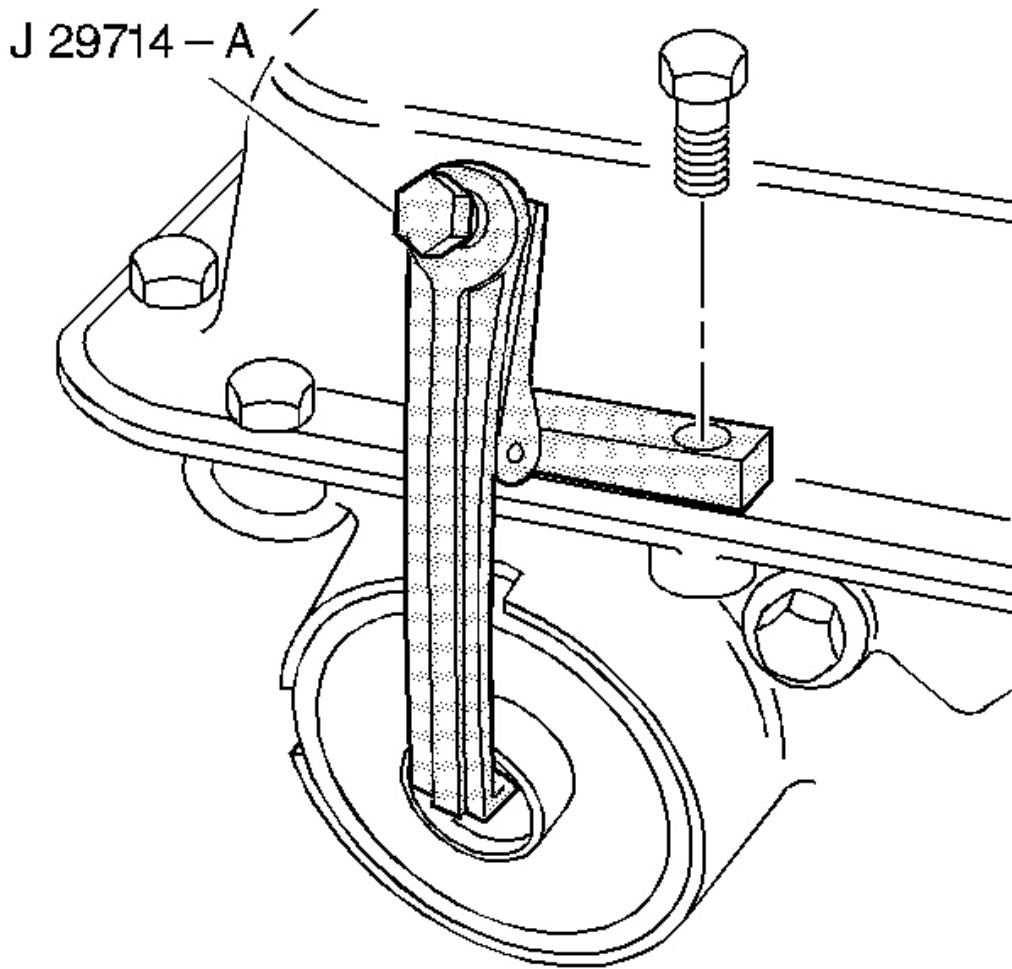

Fig. 468: Installing J 29714-A
Courtesy of GENERAL MOTORS CORP.

8. Install the **J 29714-A** . See Special Tools.

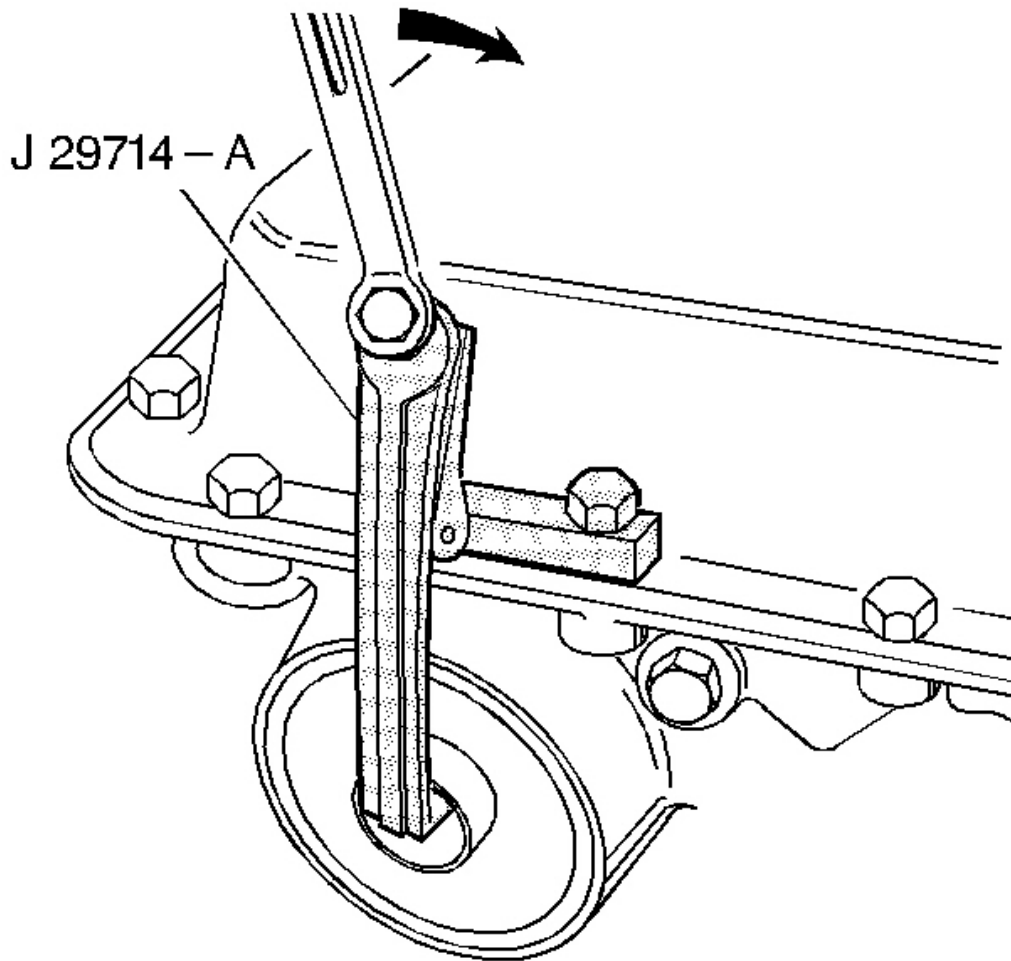

Fig. 469: Compressing Servo Cover With J 29714-A
Courtesy of GENERAL MOTORS CORP.

9. Tighten the bolt on the **J 29714-A** in order to compress the servo cover. See **Special Tools**.

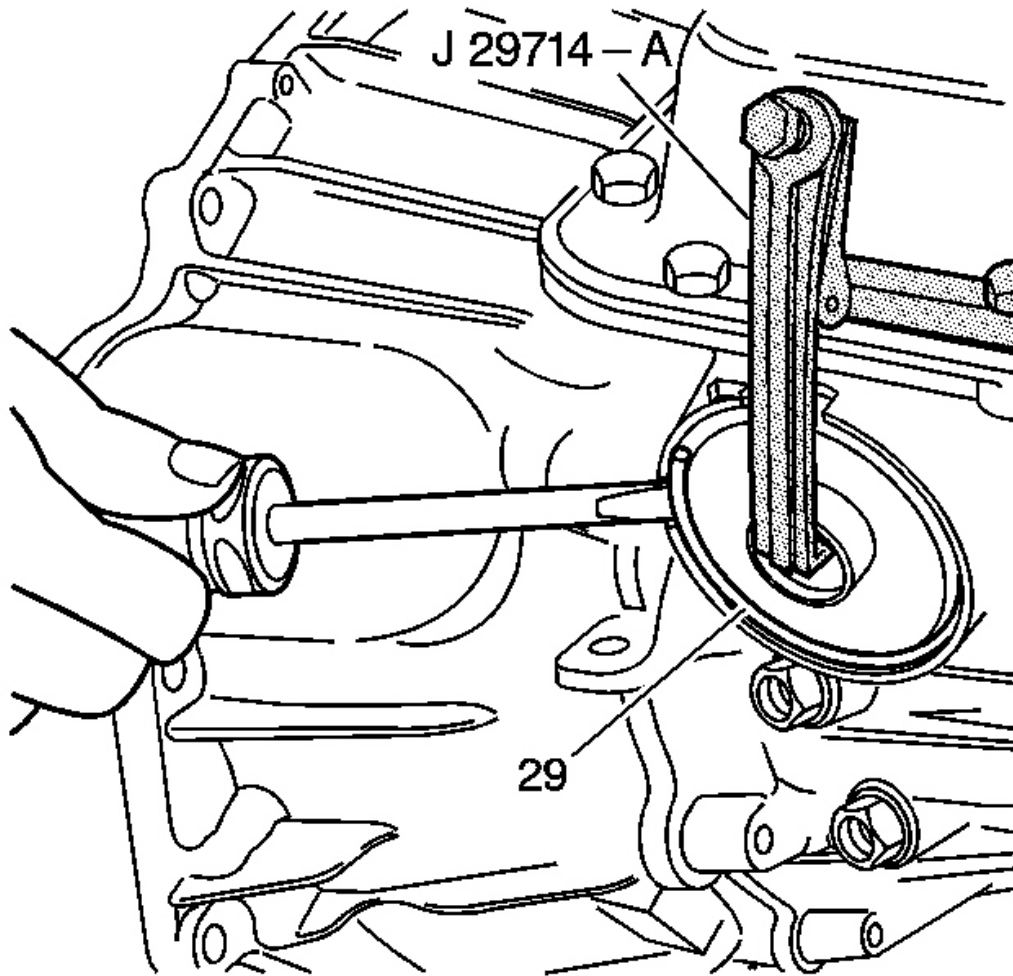

Fig. 470: Locating Servo Cover Retaining Ring
Courtesy of GENERAL MOTORS CORP.

10. Install the servo cover retaining ring (29).

TORQUE CONVERTER END PLAY INSPECTION

Tools Required

- **J 8001** Dial Indicator Set
- **J 26900-13** Magnetic Indicator Base

- **J 35138** Converter End Play Checker. See Special Tools.
- **J 39195** Converter End Play Check Tool. See Special Tools.

Inspection procedure

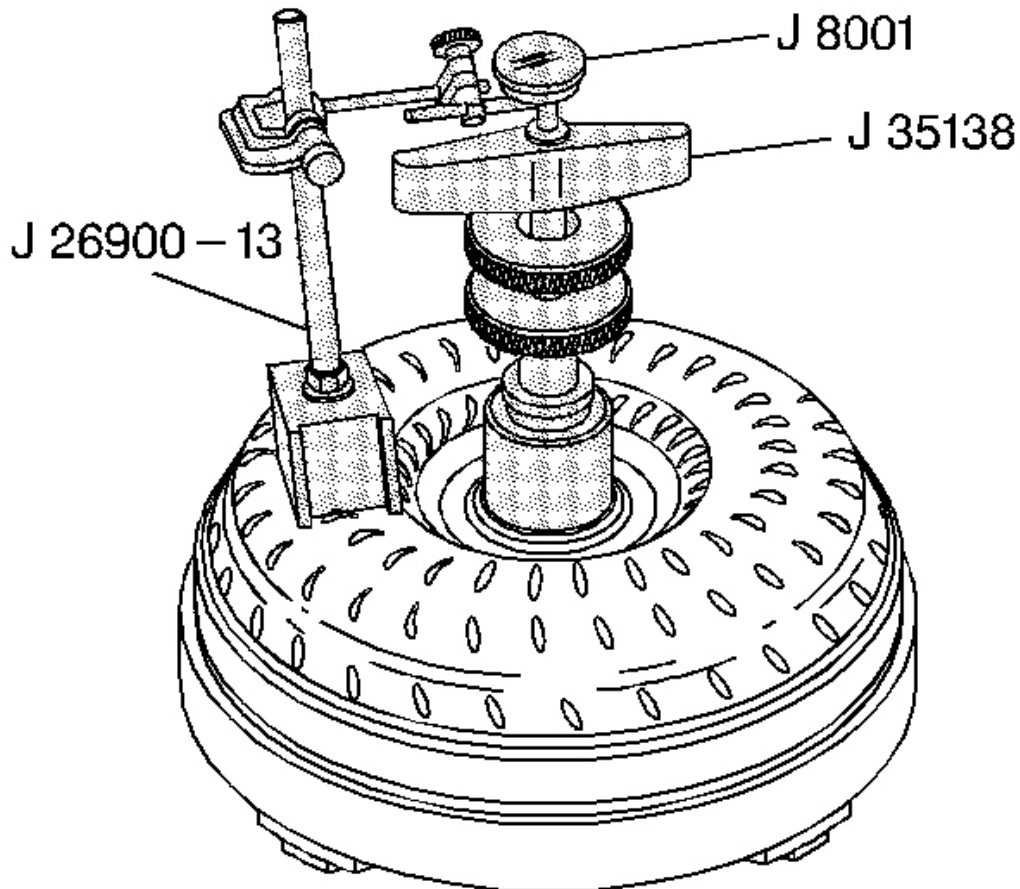

Fig. 471: Identifying J 35138, J 26900-13 & J 8001
Courtesy of GENERAL MOTORS CORP.

1. Inspect the torque converter and replace if any of the following conditions exist:
 - Evidence of damage to the pump assembly.
 - Metal particles are found after flushing the cooler and cooler lines.
 - External leaks in the hub area.

- Converter pilot is broken, damaged or poor fit into the crankshaft.
- Converter hub is scored or damaged.
- Internal damage to the stator.
- Contamination from engine coolant.
- Excessive end play.

**IMPORTANT: The torque converter should not be replaced if the fluid has an odor, discoloration or no evidence of metal or clutch plate material.
Flushing the torque converter is not recommended.**

2. Install the **J 35138** , the **J 26900-13** and the **J 8001** or **J 39195** to be used with the 300 mm torque converter. See **Special Tools**.

Specification:

- The end play for a 245 mm torque converter should be 0-0.38 mm (0-0.015 in).
- The end play for a 298 mm torque converter should be 0.1-0.48 mm (0.004-0.019 in).
- The end play for a 258 mm and 300 mm torque converter should be 0.1-0.5 mm (0.004-0.020 in).

3. Remove the tools.

TORQUE CONVERTER INSTALLATION

Tools Required

J 21366 Converter Holding Strap

Installation Procedure

CAUTION: The torque converter weighs approximately 65 lbs. Personal injury may result if you lift the torque converter improperly.

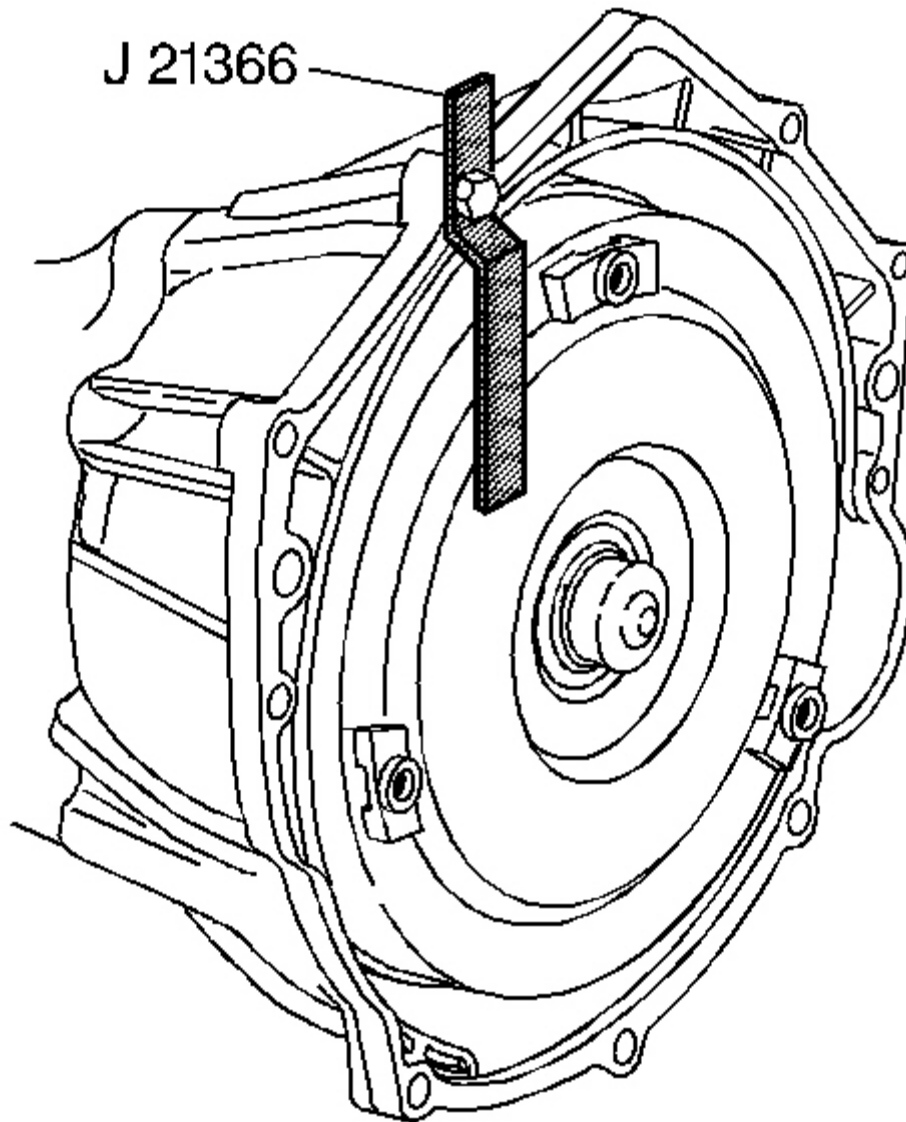

Fig. 472: View Of J 21366 Installed On Torque Converter
Courtesy of GENERAL MOTORS CORP.

1. Install the torque converter.
2. Install the **J 21366** .

HOLDING FIXTURE REMOVAL

Tools Required

J 8763-B Holding Fixture and Base. See Special Tools.

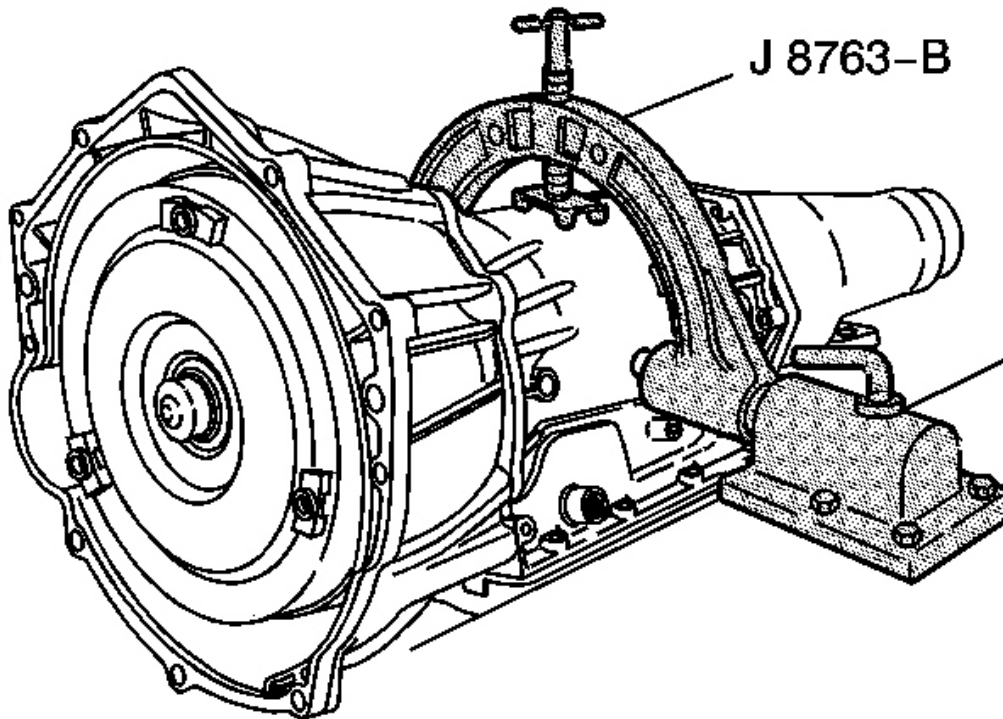

Fig. 473: View Of J 8763-B
Courtesy of GENERAL MOTORS CORP.

Removal Procedure

Remove the transmission from the **J 8763-B** . See Special Tools.

DESCRIPTION AND OPERATION

TRANSMISSION GENERAL INFORMATION

How to Use This Section

This section provides the following information:

- General diagnosis information on transmissions
- Procedures for diagnosing the Hydra-matic transmission

When you diagnose any condition of the Hydra-matic transmission, begin with A Diagnostic Starting Point. This procedure indicates the proper path of diagnosing the transmission by describing the basic checks. This procedure will then refer you to the locations of specific checks. After you have determined the cause of a condition, refer to **REPAIR INSTRUCTIONS - Off Vehicle** for repair procedures. If the faulty component is not serviceable without removing the transmission from the vehicle, refer to **REPAIR INSTRUCTIONS - On Vehicle** for repair information.

Basic Knowledge

NOTE: Do not, under any circumstances, attempt to diagnose a powertrain condition without basic knowledge of this powertrain. If you perform diagnostic procedures without this basic knowledge, you may incorrectly diagnose the condition or damage the powertrain components.

You must be familiar with some basic electronics in order to use this section of the service manual. You should also be able to use the following special tools:

- A digital multimeter (DMM)
- A circuit tester
- Jumper wires or leads
- A line pressure gage set

Diagnosis

NOTE: If you probe a wire with a sharp instrument and do not properly seal the wire afterward, the wire corrodes and an open circuit results.

Diagnostic test probes are now available that allow you to probe individual wires without leaving the wire open to the environment. These probe devices are inexpensive and easy to install and they permanently seal the wire from corrosion.

DEFINITIONS AND ABBREVIATIONS

2007 Hummer H3

2007 TRANSMISSION Automatic Transmission - 4L60-E/4L65-E/4L70-E - H3

Throttle Positions

Engine Braking

A condition where the engine friction is used to slow the vehicle by manually downshifting during a zero throttle coastdown.

Full Throttle Detent Downshift

A quick apply of the accelerator pedal to its full travel, forcing a downshift.

Heavy Throttle

Approximately 3/4 of accelerator pedal travel (75 percent throttle position).

Light Throttle

Approximately 1/4 of accelerator pedal travel (25 percent throttle position).

Medium Throttle

Approximately 1/2 of accelerator pedal travel (50 percent throttle position).

Minimum Throttle

The least amount of throttle opening required for an upshift.

Wide Open Throttle (WOT)

Full travel of the accelerator pedal (100 percent throttle position).

Zero Throttle Coastdown

A full release of the accelerator pedal while the vehicle is in motion and in drive range.

Shift Condition Definitions

Bump

A sudden and forceful apply of a clutch or a band.

Chuggle

2007 Hummer H3

2007 TRANSMISSION Automatic Transmission - 4L60-E/4L65-E/4L70-E - H3

A bucking or jerking. This condition may be most noticeable when the converter clutch is engaged. It is similar to the feel of towing a trailer.

Delayed

A condition where a shift is expected but does not occur for a period of time. This could be described as a clutch or band engagement that does not occur as quickly as expected during a part throttle or wide open throttle apply of the accelerator or during manual downshifting to a lower range. This term is also defined as LATE or EXTENDED.

Double Bump (Double Feel)

Two sudden and forceful applies of a clutch or a band.

Early

A condition where the shift occurs before the car has reached proper speed. This condition tends to labor the engine after the upshift.

End Bump

A firmer feel at the end of a shift than at the start of the shift. This is also defined as END FEEL or SLIP BUMP.

Firm

A noticeably quick apply of a clutch or band that is considered normal with a medium to heavy throttle. This apply should not be confused with HARSH or ROUGH.

Flare

A quick increase in engine RPM along with a momentary loss of torque. This most generally occurs during a shift. This condition is also defined as SLIPPING.

Harsh (Rough)

A more noticeable apply of a clutch or band than FIRM. This condition is considered undesirable at any throttle position.

Hunting

A repeating quick series of upshifts and downshifts that causes a noticeable change in engine

2007 Hummer H3

2007 TRANSMISSION Automatic Transmission - 4L60-E/4L65-E/4L70-E - H3

RPM, such as a 4-3-4 shift pattern. This condition is also defined as BUSYNESS.

Initial Feel

A distinctly firmer feel at the start of a shift than at the finish of the shift.

Late

A shift that occurs when the engine RPM is higher than normal for a given amount of throttle.

Shudder

A repeating jerking condition similar to CHUGGLE but more severe and rapid. This condition may be most noticeable during certain ranges of vehicle speed.

Slipping

A noticeable increase in engine RPM without a vehicle speed increase. A slip usually occurs during or after initial clutch or band apply.

Soft

A slow, almost unnoticeable clutch or band apply with very little shift feel.

Surge

A repeating engine related condition of acceleration and deceleration that is less intense than CHUGGLE.

Tie-Up

A condition where two opposing clutch and/or bands are attempting to apply at the same time causing the engine to labor with a noticeable loss of engine RPM.

Noise Conditions

Drive Link Noise

A whine or growl that increases or fades with vehicle speed and is most noticeable under a light throttle acceleration. It may also be noticeable in PARK or NEUTRAL operating ranges with the vehicle stationary.

Final Drive Noise

A hum related to vehicle speed which is most noticeable under a light throttle acceleration.

Planetary Gear Noise

A whine related to vehicle speed, which is most noticeable in FIRST gear, SECOND gear, FOURTH gear or REVERSE. The condition may become less noticeable or go away, after an upshift.

Pump Noise

A high pitched whine that increases in intensity with engine RPM. This condition may also be noticeable in all operating ranges with the vehicle stationary or moving.

Torque Converter Noise

A whine usually noticed when a vehicle is stopped and the transmission is in DRIVE or REVERSE. The noise will increase with engine RPM.

Transmission Abbreviations

A/C

Air Conditioning

AC

Alternating Current

AT

Automatic Transmission

DC

Direct Current

DIC

Driver Information Center

2007 Hummer H3

2007 TRANSMISSION Automatic Transmission - 4L60-E/4L65-E/4L70-E - H3

DLC

Diagnostic Link Connector

DMM

Digital Multimeter

DTC

Diagnostic Trouble Code

ECT

Engine Coolant Temperature

EMI

Electromagnetic Interference

IAT

Intake Air Temperature

IGN

Ignition

IPC

Instrument Panel Cluster

ISS

Input Speed Sensor

MAP

Manifold Absolute Pressure

MIL

2007 Hummer H3

2007 TRANSMISSION Automatic Transmission - 4L60-E/4L65-E/4L70-E - H3

Malfunction Indicator Lamp

NC

Normally Closed

NO

Normally Open

OBD

On Board Diagnostic

OSS

Output (Shaft) Speed Sensor

PC

Pressure Control

PCM

Powertrain Control Module

PWM

Pulse Width Modulation

RPM

Revolutions Per Minute

SS

Shift Solenoid

TAP

Transmission Adaptive Pressure

2007 Hummer H3

2007 TRANSMISSION Automatic Transmission - 4L60-E/4L65-E/4L70-E - H3

TCC

Torque Converter Clutch

TCM

Transmission Control Module

TFP

Transmission Fluid Pressure

TFT

Transmission Fluid Temperature

TP

Throttle Position

TV

Throttle Valve

VSS

Vehicle Speed Sensor

WOT

Wide Open Throttle

4WD

Four-Wheel Drive

TRANSMISSION IDENTIFICATION INFORMATION

2007 Hummer H3

2007 TRANSMISSION Automatic Transmission - 4L60-E/4L65-E/4L70-E - H3

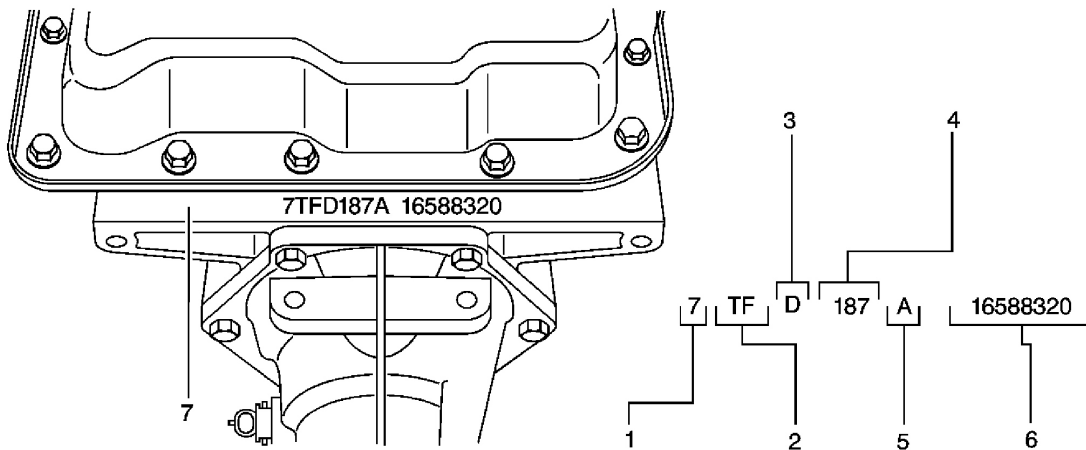
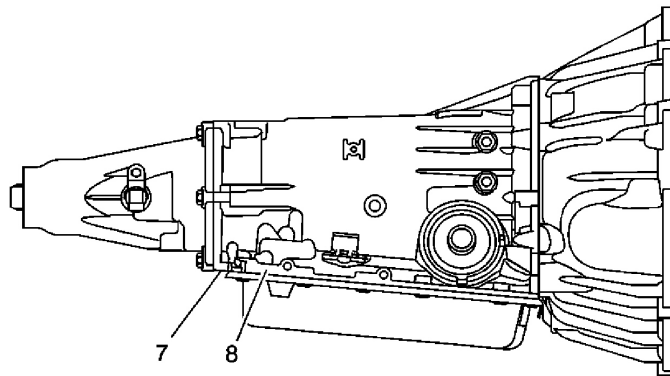

Fig. 474: Toledo Build
Courtesy of GENERAL MOTORS CORP.

Callouts For Fig. 474

Callout	Component Name
1	7 = 2007
2	Model
3	Hydra-Matic 4L60-E
4	Julian Date or Day of the Year
5	Shift Built, See Shift Build Chart
6	Serial Number
7	Case/Pan Frame Rail Location
7	Case/Pan Frame Rail Location
8	Optional Transmission ID Location, Tag Is Used as a Back-Up If Unable To Etch Case/Pan Area and To Bar Code Scan

2007 Hummer H3

2007 TRANSMISSION Automatic Transmission - 4L60-E/4L65-E/4L70-E - H3

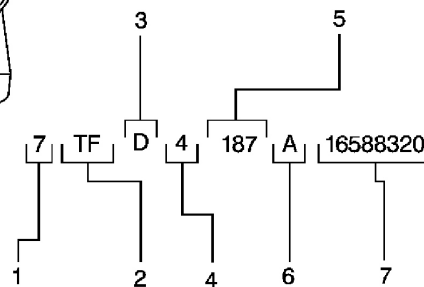
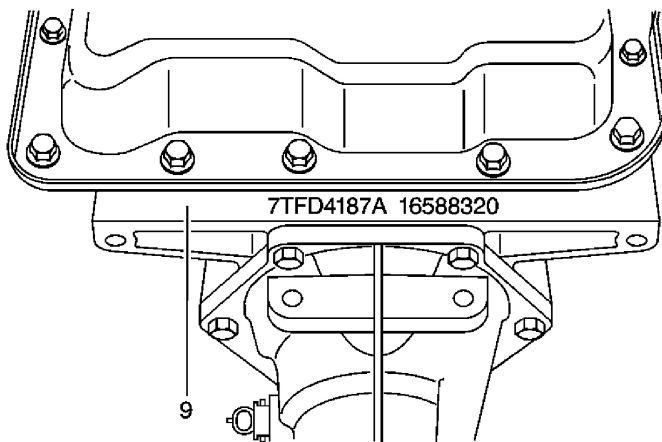
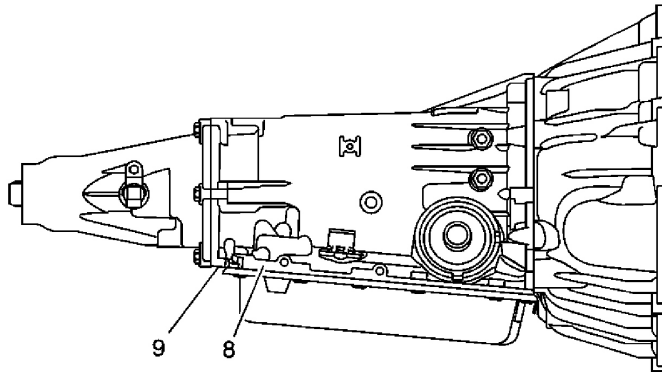

Fig. 475: Ramos Arizpe, Mexico
 Courtesy of GENERAL MOTORS CORP.

Callouts For Fig. 475

Callout	Component Name
1	7 = 2007
2	Model
3	Hydra-Matic 4L60-E
4	Plant of Manufacture, 4 is Ramos
5	Julian Date or Day of the Year
6	Shift Built, See Shift Build Chart
7	Transmission Serial Number
8	Optional Transmission ID Tag Location, Tag Is Used as a Back-Up If Unable To Etch Case/Pan Area and To Bar Code Scan
9	Case/Pan Frame Rail Area

2007 Hummer H3

2007 TRANSMISSION Automatic Transmission - 4L60-E/4L65-E/4L70-E - H3

9 Case/Pan Frame Rail Area

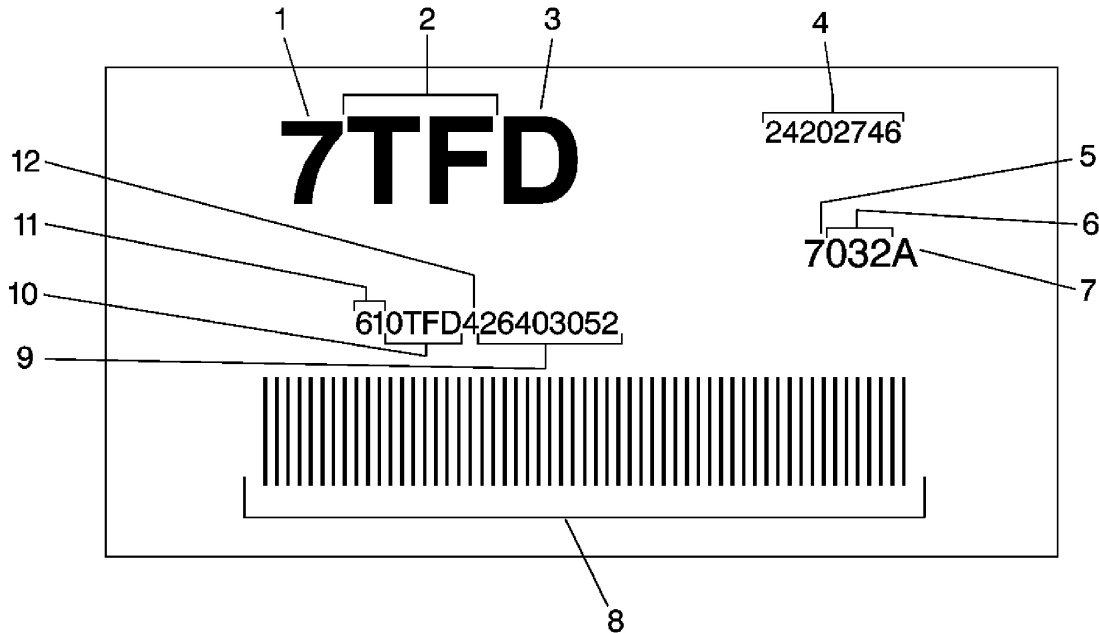

Fig. 476: Bar Code Label Contents
 Courtesy of GENERAL MOTORS CORP.

Callouts For Fig. 476

Callout	Component Name
1	7 = 2007
2	Model
3	Hydra-Matic 4L60-E
4	Transmission Asm. as Shipped Number
5	7 = Model Year
6	Julian Date or Day of the Year
7	Letter After Julian Date Identifies the Plant Shift Build, See Shift Build Chart
8	Bar Code
9	Serial Number
10	Broadcast Code
11	Transmission ID
12	Build Location Y = Toledo, OH, 4 = Ramos Arizpe, Mexico

2007 Hummer H3

2007 TRANSMISSION Automatic Transmission - 4L60-E/4L65-E/4L70-E - H3

Plant and Shift Build Chart

Plant	Build Line	1st Shift	2nd Shift	3rd Shift
Toledo, OH	ML1	J	W	X
	ML2	A	C	Not Used
	ML3	B	H	Not Used
	ML4	S	L	V
	ML5	K	E	Z
Ramos Arizpe, Mexico	1	A	-	-

TRANSMISSION COMPONENT AND SYSTEM DESCRIPTION

The mechanical components of the 4L60-E are as follows:

- A torque converter with an electronically controlled capacity clutch (ECCC)

This transmission is equipped with an ECCC. The pressure plate does not fully lock to the torque converter cover. Instead, the pressure plate maintains a small amount of slippage, about 20 RPM, in SECOND, THIRD and FOURTH gears, depending on the vehicle application. ECCC was developed to reduce the possibility of noise, vibration or chuggle caused by TCC apply. Typical apply speeds are 49-52 km/h (30-32 mph) in THIRD gear and 65-73 km/h (40-45 mph) in FOURTH gear. Full lockup is available at highway speeds on some applications.

- Torque converter assembly
- Servo assembly and 2-4 band assembly
- Reverse input clutch and housing
- Overrun clutch
- Forward clutch
- 3-4 clutch
- Forward sprag clutch assembly
- Lo and reverse roller clutch assembly
- Lo and reverse clutch assembly
- Two planetary gear sets: Input and Reaction
- Oil pump assembly
- Control valve body assembly

The electrical components of the 4L60-E are as follows:

- 1-2 and 2-3 shift solenoid valves
- 3-2 shift solenoid valve assembly
- Transmission pressure control (PC) solenoid
- Torque converter clutch (TCC) solenoid valve
- TCC pulse width modulation (PWM) solenoid valve
- Automatic transmission fluid pressure (TFP) manual valve position switch
- Automatic transmission fluid temperature (TFT) sensor
- Vehicle speed sensor assembly

For more information, refer to **Electronic Component Description**.

TRANSMISSION ADAPTIVE FUNCTIONS

The 4L60-E transmission utilizes a line pressure control system during upshifts to compensate for the normal wear of transmission components. By adjusting the line pressure, the powertrain control module (PCM)/transmission control module (TCM) can maintain acceptable transmission shift times. This process is known as "adaptive learning" or "shift adapts" and is similar to the closed loop fuel control system used for the engine.

In order for the PCM/TCM to perform a "shift adapt," it must first identify if an upshift is acceptable to analyze. For example, upshifts that occur during cycling of the A/C compressor or under extreme throttle changes could cause the PCM/TCM to incorrectly adjust line pressure. When an upshift is initiated, a number of contingencies, such as throttle position, transmission temperature and vehicle speed, are checked in order to determine if the actual shift time is valid to compare to a calibrated desired shift time. If all the contingencies are met during the entire shift, then the shift is considered valid and the adapt function may be utilized if necessary.

Once an adaptable shift is identified, the PCM/TCM compares the actual shift time to the desired shift time and calculates the difference between them. This difference is known as the shift error. The actual shift time is determined from the time that the PCM/TCM commands the shift to the start of the engine RPM drop initiated by the shift. If the actual shift time is longer than the calibrated desired shift time, a soft feel or slow engagement, then the PCM/TCM decreases current to the pressure control (PC) solenoid in order to increase line pressure for the next, same, upshift under identical conditions. If the actual shift time is shorter than the calibrated desired shift time, a firm engagement, then the PCM/TCM increases current to the PC solenoid in order to decrease line pressure for the next, same, upshift under identical conditions.

The purpose of the adapt function is to automatically compensate the shift quality for the various vehicle shift control systems. It is a continuous process that will help to maintain optimal shift quality throughout the life of the vehicle.

Clearing Transmission Adaptive Pressure (TAP)

Transmission adaptive pressure (TAP) information is displayed and may be reset using a scan tool.

The adapt function is a feature of the powertrain control module (PCM)/transmission control module (TCM) that either adds or subtracts line pressure from a calibrated base line pressure in order to compensate for normal transmission wear. The TAP information is divided into 13 units, called cells. The cells are numbered 4 through 14. Each cell represents a given torque range. TAP cell 4 is the lowest adaptable torque range and TAP cell 14 is the highest adaptable torque range. It is normal for TAP cell values to display zero or negative numbers. This indicates that the PCM/TCM has adjusted line pressure at or below the calibrated base line pressure.

Updating TAP information is a learning function of the PCM/TCM designed to maintain acceptable shift times. It is not recommended that TAP information be reset unless one of the following repairs has been made:

- Transmission overhaul or replacement
- Repair or replacement of an apply or release component, clutch, band, piston, servo
- Repair or replacement of a component or assembly which directly affects line pressure

Resetting the TAP values using a scan tool will erase all learned values in all cells. As a result, the PCM/TCM will need to relearn TAP values. Transmission performance may be affected as new TAPs are learned. Learning can only take place when the PCM/TCM has determined that an acceptable shift has occurred. The PCM/TCM must also relearn TAP values if it is replaced.

ELECTRONIC COMPONENT DESCRIPTION

1-2 and 2-3 Shift Solenoid Valves

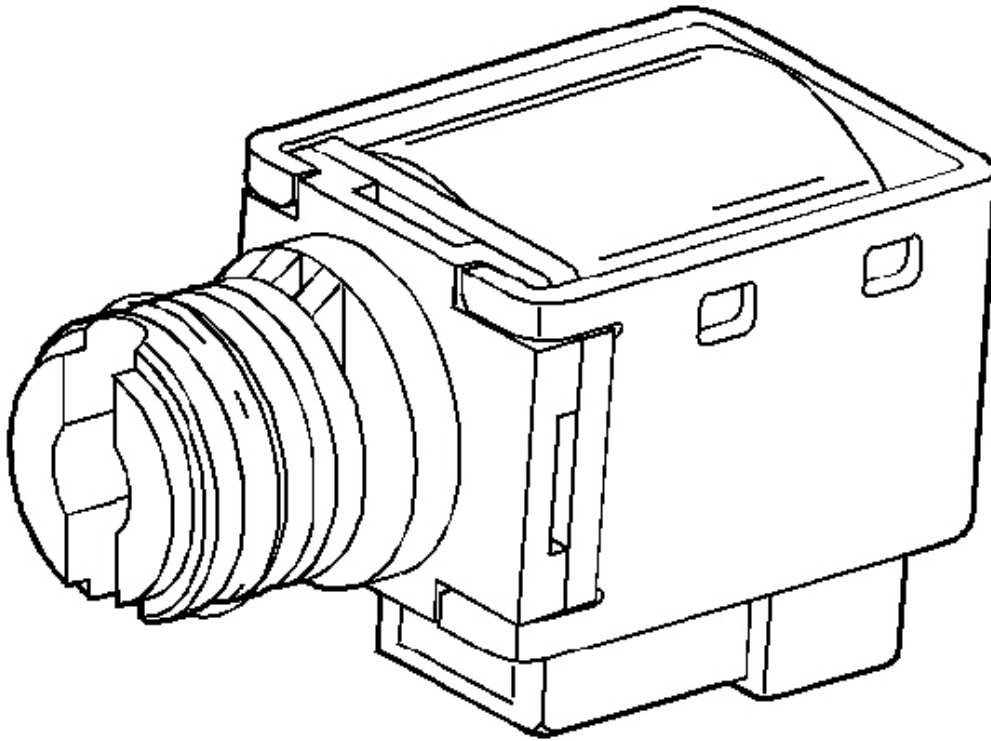

Fig. 477: View Of 1-2 & 2-3 Shift Solenoid Valve
Courtesy of GENERAL MOTORS CORP.

The 1-2 and 2-3 shift solenoid valves (also called A and B solenoids) are identical devices that control the movement of the 1-2 and 2-3 shift valves. The 3-4 shift valve is not directly controlled by a shift solenoid. The solenoids are normally-open exhaust valves that work in 4 combinations to shift the transmission into different gears.

The powertrain control module (PCM) or transmission control module (TCM) energizes each solenoid by grounding the solenoid through an internal quad driver. This sends current through the coil winding in the solenoid and moves the internal plunger out of the exhaust position. When ON, the solenoid redirects fluid to move a shift valve.

IMPORTANT: The manual valve hydraulically can override the shift solenoids. Only in D4 do the shift solenoid states totally determine what gear the transmission is in. In the other manual valve positions,

the transmission shifts hydraulically and the shift solenoid states CATCH UP when the throttle position and the vehicle speed fall into the correct ranges.

The PCM/TCM-controlled shift solenoids eliminate the need for TV and governor pressures to control shift valve operation.

3-2 Shift Solenoid Valve Assembly

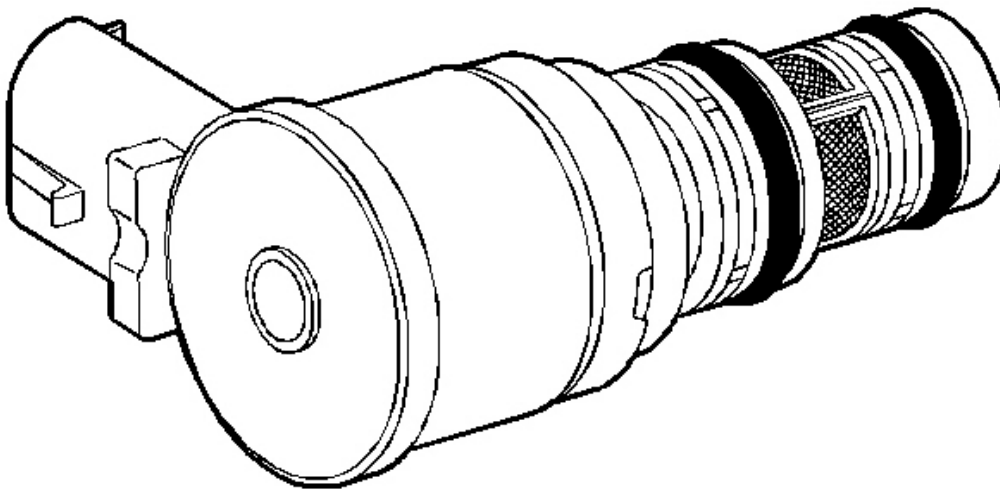

Fig. 478: View Of 3-2 Shift Solenoid Valve Assembly
Courtesy of GENERAL MOTORS CORP.

The 3-2 shift solenoid valve assembly is a normally-closed, 3-port, ON/OFF device that is used in order to improve the 3-2 downshift. The solenoid regulates the release of the 3-4 clutch and the 2-4 band apply.

Transmission Pressure Control Solenoid

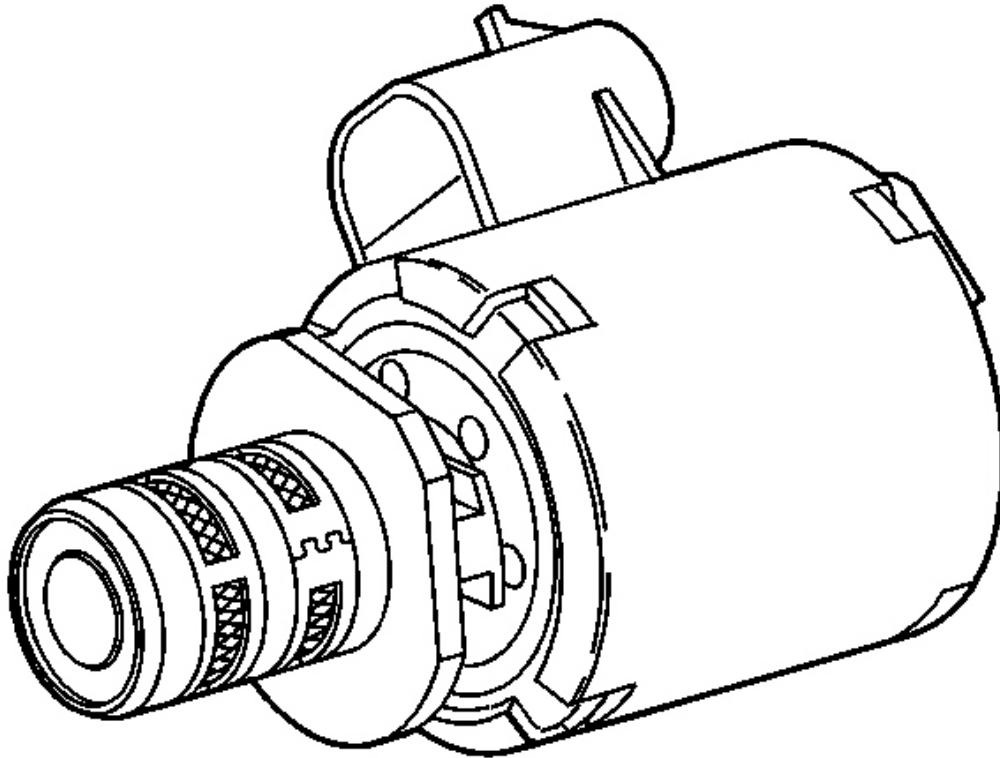

Fig. 479: View Of Transmission Pressure Control Solenoid
Courtesy of GENERAL MOTORS CORP.

The transmission pressure control solenoid is an electronic pressure regulator that controls pressure based on the current flow through its coil winding. The magnetic field produced by the coil moves the solenoid's internal valve which varies pressure to the pressure regulator valve.

The powertrain control module (PCM) or transmission control module (TCM) controls the pressure control solenoid by commanding current between 0.1 and 1.1 amps. This changes the duty cycle of the solenoid, which can range between 5-95 percent, typically less than 60 percent. High amperage (1.1 amps) corresponds to minimum line pressure and low amperage (0.1 amp) corresponds to maximum line pressure. If the solenoid loses power, the transmission defaults to maximum line pressure.

The PCM/TCM commands the line pressure values, using inputs such as engine speed and throttle position sensor voltage.

The pressure control solenoid takes the place of the throttle valve or the vacuum modulator that was used on past model transmissions.

Torque Converter Clutch Solenoid Valve

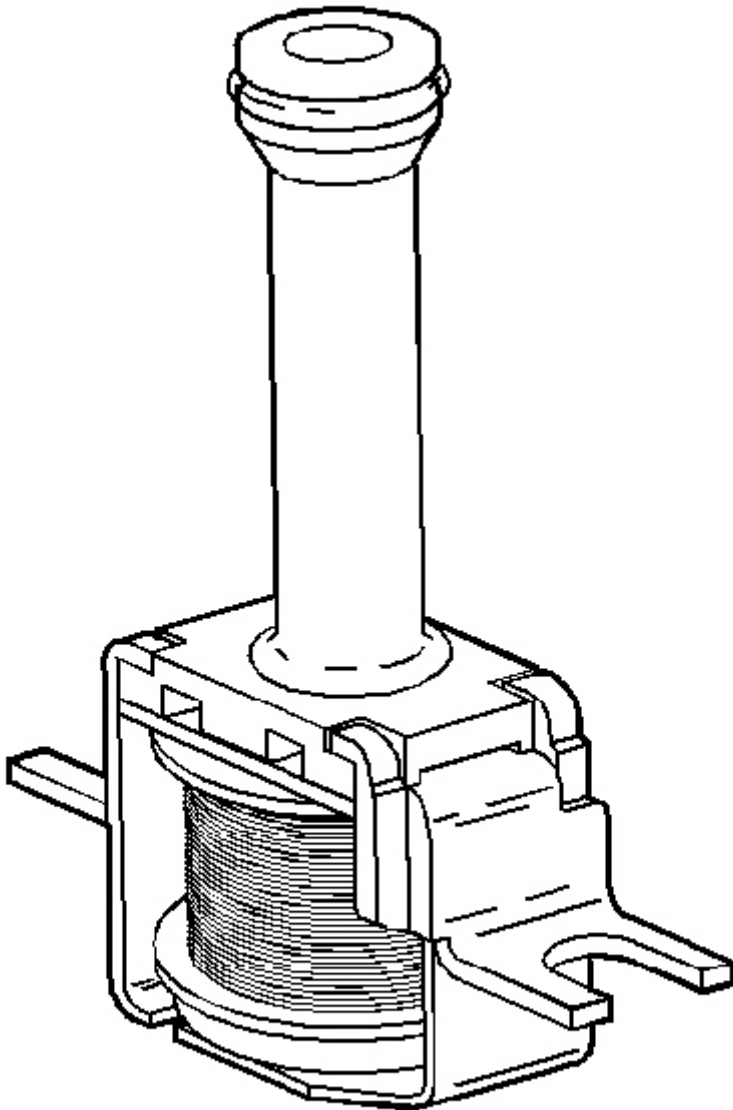

Fig. 480: View Of Torque Converter Clutch Solenoid Valve
Courtesy of GENERAL MOTORS CORP.

The torque converter clutch (TCC) solenoid valve is a normally-open exhaust valve that is used to control torque converter clutch apply and release. When grounded, energized, by the powertrain control module (PCM) or transmission control module (TCM), the TCC solenoid valve stops converter signal oil from exhausting. This causes converter signal oil pressure to increase and move the TCC solenoid valve into the apply position.

Torque Converter Clutch Pulse Width Modulation Solenoid Valve

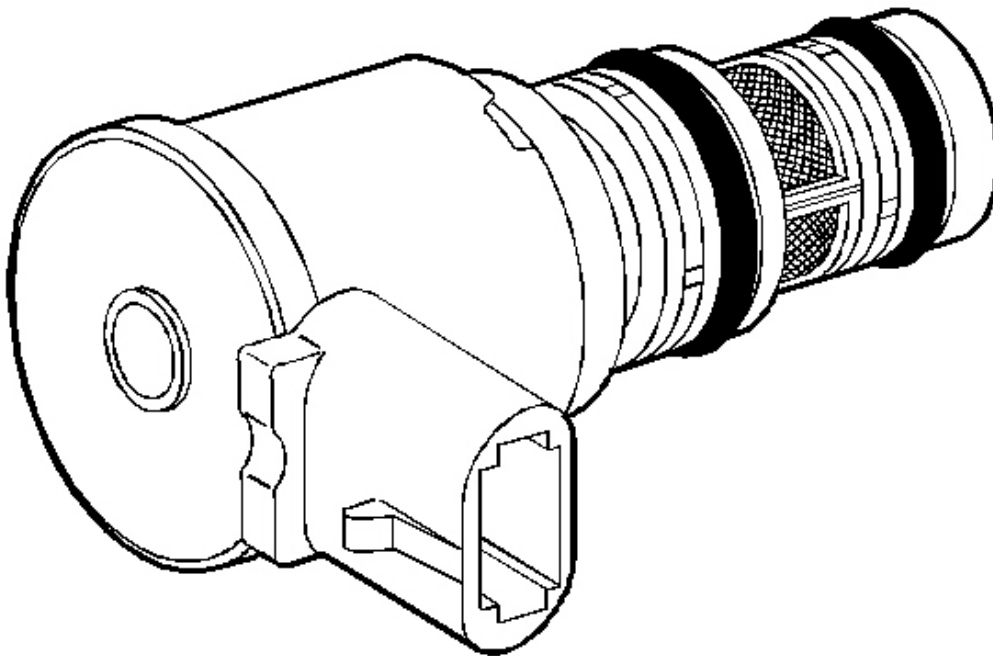

Fig. 481: View Of Torque Converter Clutch Pulse Width Modulation Solenoid Valve
Courtesy of GENERAL MOTORS CORP.

The torque converter clutch pulse width modulation solenoid valve controls the fluid acting on the converter clutch valve. The converter clutch valve controls the torque converter clutch (TCC) apply and release. This solenoid is attached to the control valve body assembly within the transmission. The TCC PWM solenoid valve provides a smooth engagement of the torque converter clutch by operating during a duty cycle percent of ON time.

Transmission Fluid Pressure (TFP) Manual Valve Position Switch

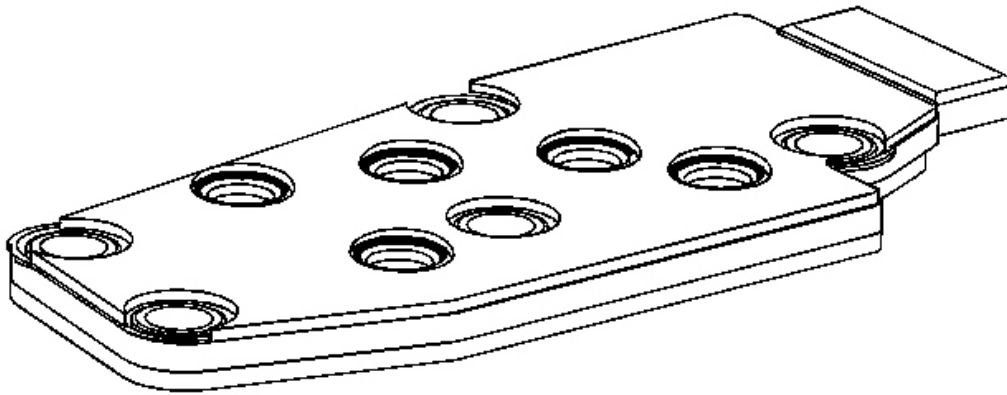

Fig. 482: View Of Transmission Fluid Pressure (TFP) Manual Valve Position Switch
Courtesy of GENERAL MOTORS CORP.

IMPORTANT: Seven valid combinations and 2 invalid combinations are available from the transmission fluid pressure (TFP) manual valve position switch. Refer to the Transmission Fluid Pressure Manual Valve Position Switch Logic table for valid/invalid combinations for range signal circuits A, B and C.

The TFP manual valve position switch consists of 5 pressure switches (2 normally-closed and 3 normally-open) on the control valve body that sense whether fluid pressure is present in 5 different valve body passages. The combination of switches that are open and closed is used by the powertrain control module (PCM) or transmission control module (TCM) in order to determine the actual manual valve position. The TFP manual valve position switch, however, cannot distinguish between PARK and NEUTRAL because the monitored valve body pressures are identical in both cases.

The switches are wired to provide three signal lines that are monitored by the PCM/TCM. These signals are used to help control line pressure, torque converter clutch apply and shift solenoid valve operation. Voltage at each of the signal lines is either 0 or 12 volts.

In order to monitor the TFP manual valve position switch operation, the PCM/TCM compares the actual voltage combination of the switches to a TFP combination table stored in its memory.

The TFP manual valve position switch signal voltage can be measured from each pin-to-ground

2007 Hummer H3

2007 TRANSMISSION Automatic Transmission - 4L60-E/4L65-E/4L70-E - H3

and compared to the combination table. On the automatic transmission (AT) wiring harness, pin N is signal A, pin R is signal B and pin P is signal C. With the AT wiring harness assembly connected and the engine running, a voltage measurement of these three lines will indicate a high reading (near 12 volts) when a circuit is open and a low reading (0 volts) when the circuit is switched to ground.

The transmission fluid temperature (TFT) sensor is part of the TFP manual valve position switch assembly.

Vehicle Speed Sensor Assembly

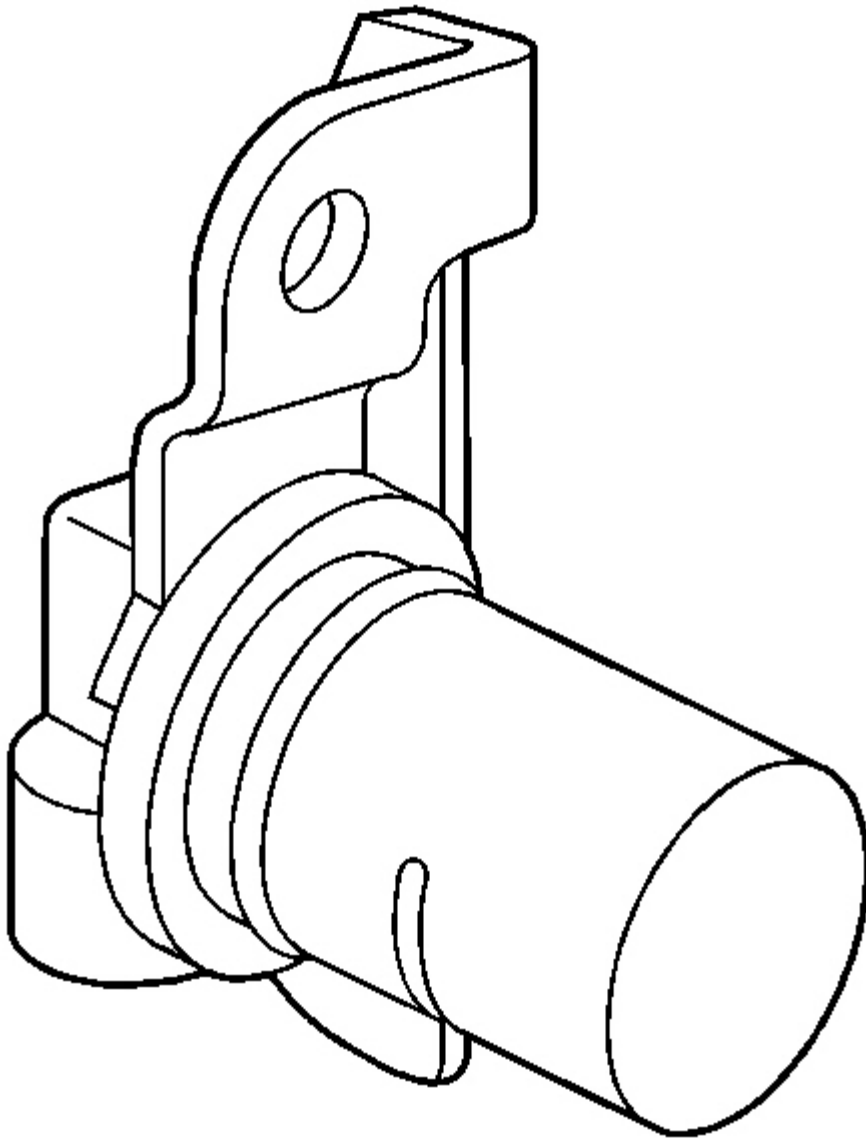

Fig. 483: Vehicle Speed Sensor Assembly
Courtesy of GENERAL MOTORS CORP.

The vehicle speed sensor (VSS) provides vehicle speed information to the powertrain control module (PCM) or transmission control module (TCM). The VSS is a permanent magnet (PM) generator. The PM generator produces a pulsing AC voltage as rotor teeth on the transmission

output shaft pass through the sensor's magnetic field. The AC voltage level and the number of pulses increase as the speed of the vehicle increases. Output voltage varies with speed from a minimum of 0.5 volts at 100 RPM to more than 100 volts at 8,000 RPM. The PCM/TCM converts the pulsing voltage to vehicle speed. The PCM/TCM uses the vehicle speed signal to determine shift timing and TCC scheduling.

Automatic Transmission Fluid Temperature Sensor

The automatic transmission fluid temperature (TFT) sensor is part of the automatic transmission fluid pressure (TFP) manual valve position switch. The TFT sensor is a resistor or thermistor, which changes value based on temperature. The sensor has a negative-temperature coefficient. This means that as the temperature increases, the resistance decreases and as the temperature decreases, the resistance increases.

The powertrain control module (PCM) or transmission control module (TCM) supplies a 5-volt reference signal to the TFT sensor and measures the voltage drop in the circuit. When the transmission fluid is cold, the sensor resistance is high and the PCM/TCM detects high signal voltage. As the fluid temperature warms to a normal operating temperature, the resistance becomes less and the signal voltage decreases. Refer to **TRANSMISSION FLUID TEMPERATURE SENSOR SPECIFICATIONS** for a complete comparison of sensor resistance, temperature and signal voltage.

The PCM/TCM uses the TFT sensor information to control shift quality and TCC application.

Transmission Range Switch

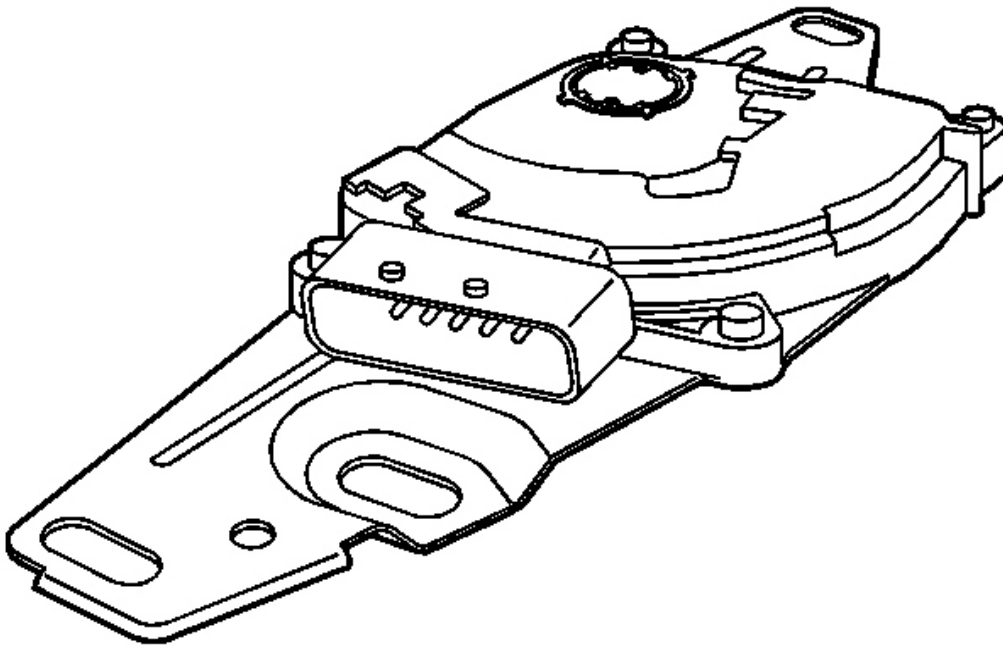

Fig. 484: View Of Transmission Range Switch
Courtesy of GENERAL MOTORS CORP.

The transmission range (TR) switch is part of the park/neutral position (PNP) and backup lamp switch assembly, which is externally mounted on the transmission manual shaft. The TR switch contains four internal switches that indicate the transmission gear range selector lever position. The powertrain control module (PCM) or transmission control module (TCM) supplies ignition voltage to each switch circuit. As the gear range selector lever is moved, the state of each switch may change, causing the circuit to open or close. An open circuit or switch indicates a high voltage signal. A closed circuit or switch indicates a low voltage signal. The PCM/TCM detects the selected gear range by deciphering the combination of the voltage signals. The PCM/TCM compares the actual voltage combination of the switch signals to a TR switch combination chart stored in memory.

AUTOMATIC TRANSMISSION INLINE 20-WAY CONNECTOR DESCRIPTION

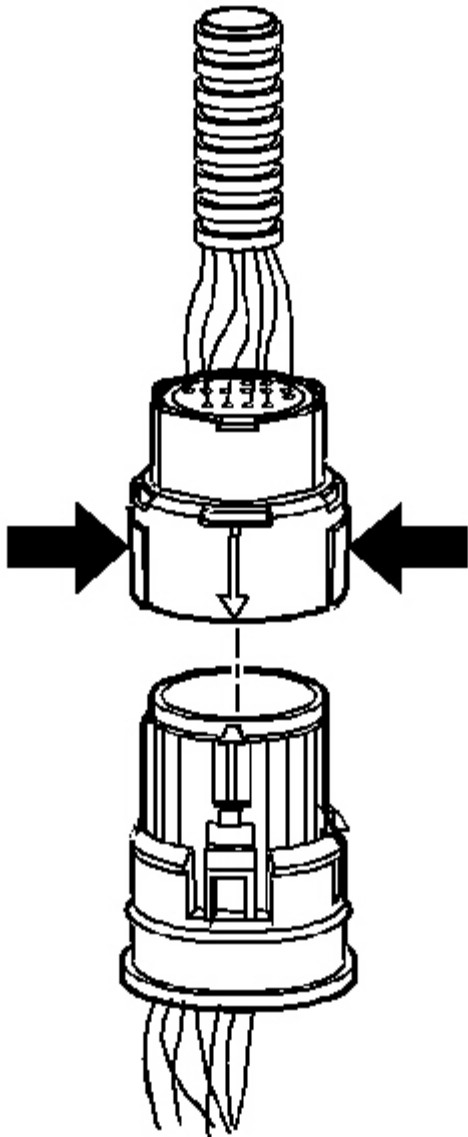

Fig. 485: Identifying Automatic Transmission In-Line 20-Way Connector
Courtesy of GENERAL MOTORS CORP.

The transmission electrical connector is an important part of the transmission operating system. Any interference with the electrical connection can cause the transmission to set diagnostic trouble codes or affect proper operation.

The following items can affect the electrical connection:

- Bent pins in the connector from rough handling during connection and disconnection
- Wires backing away from the pins or coming uncrimped, in either the internal or the external wiring harness
- Dirt contamination entering the connector when disconnected
- Pins in the internal wiring connector backing out of the connector or pushed out of the connector during reconnection
- Transmission fluid leaking into the connector, wicking up into the external wiring harness and degrading the wire insulation
- Moisture intrusion in the connector
- Low pin retention in the external connector from excessive connection and disconnection of the wiring connector assembly
- Pin corrosion from contamination
- Damaged connector assembly

Remember the following points:

- In order to remove the connector, squeeze the two tabs toward each other and pull straight up without pulling by the wires.
- Limit twisting or wiggling the connector during removal. Bent pins can occur.
- Do not pry the connector off with a screwdriver or other tool.
- Visually inspect the seals to ensure that they are not damaged during handling.
- In order to reinstall the external wiring connector, first orient the pins by lining up the arrows on each half of the connector. Push the connector straight down into the transmission without twisting or angling the mating parts.
- The connector should click into place with a positive feel and/or noise.
- Whenever the transmission external wiring connector is disconnected from the internal harness and the engine is operating, DTCs will set. Clear these DTCs after reconnecting the external connector.

PARK - ENGINE RUNNING

With the gear selector lever in the PARK (P) position and the engine running, the line pressure from the oil pump assembly is directed to various components in the valve body and the oil pump.

Pressure Regulator Valve

2007 Hummer H3

2007 TRANSMISSION Automatic Transmission - 4L60-E/4L65-E/4L70-E - H3

The pressure regulator valve regulates the oil pump output (line pressure) in response to the signal fluid pressure, the spring force and the line pressure acting on the end of the valve. The line pressure is routed through the valve and into both the converter feed and the decrease fluid circuits. Regulated line pressure is also directed to the manual valve, the converter clutch valve, the actuator feed limit valve and the regulated apply valve.

Pressure Relief Valve

Controlled by spring force, this checkball limits the maximum value of the line pressure. When the line pressure reaches this limiting value, fluid is exhausted past the ball and returns to the sump.

Line Pressure Tap

The line pressure tap provides a location to measure the line pressure with a fluid pressure gage.

Actuator Feed Limit Valve

Biased by spring force and orificed AFL fluid, it limits the maximum value of line pressure entering the AFL fluid circuit. Below this limiting value, the AFL fluid pressure equals the line pressure. The AFL fluid is routed to the pressure control solenoid valve, the 3-2 control solenoid valve, the TCC PWM solenoid valve, the 1-2 and 2-3 shift solenoid valves and the 2-3 shift valve train.

Pressure Control (PC) Solenoid Valve

Controlled by the powertrain control module (PCM), the PC solenoid valve regulates the filtered AFL fluid into the torque signal fluid pressure. The PCM controls this regulation by varying the current value to the PC solenoid valve in relation to the throttle position and other vehicle operating conditions.

Torque Converter Clutch (TCC)

Torque Converter Clutch PWM Solenoid and Regulator Apply and Isolator Valve

AFL fluid is routed to the TCC PWM solenoid valve, in Park the PCM has the duty cycle turned OFF. This prevents AFL fluid from entering the converter clutch signal fluid circuit. Regulated line pressure is routed to the regulator apply valve, which is open with CC signal circuit empty and blocks line pressure from entering the regulated apply circuit. Any fluid in the regulated apply circuit will exhaust at the regulated apply valve.

TCC Solenoid Valve

IMPORTANT: TCC converter feed valve assembly (#4), in the converter feed circuit, prevents converter drain down. The orifice is smaller than the exhaust through the TCC solenoid valve. Therefore, fluid pressure does not build up at the end of the converter clutch apply valve.

Under normal operating conditions, the PCM keeps the normally open TCC solenoid valve de-energized (OFF). Converter feed fluid exhausts through the open TCC solenoid valve and spring force keeps the converter clutch apply valve in the release position.

Converter Clutch Valve

Held in the release position by spring force, it directs converter feed fluid into the release fluid circuit. Also, fluid returning from the converter in the apply fluid circuit is routed through the valve and into the cooler fluid circuit.

Torque Converter

Release fluid pressure unseats the TCC apply checkball (#9), keeps the pressure plate released from the converter cover and fills the converter with fluid. Fluid exits the converter between the converter hub and the stator shaft in the apply fluid circuit.

Cooler and Lubrication System

Cooler fluid from the converter clutch apply valve is routed through the transmission fluid cooler and into the lubrication fluid circuits.

Manual Valve

Controlled by the selector lever and the manual shaft, the manual valve is in the Park (P) position and directs the line pressure into the PR (Park/Reverse) fluid circuit. Line pressure is blocked from entering any other fluid circuit at the manual valve.

Lo and Reverse Clutch Applies

Lo and Reverse Clutch Piston

The PR fluid seats the lo and reverse clutch checkball (#10) and is orificed to the outer area of the piston. Orificing the PR fluid around the #10 checkball helps control the lo and reverse clutch apply. Also, Lo/reverse fluid pressure from the lo overrun valve acts on the inner area of the lo and reverse clutch piston in order to increase the clutch holding capacity.

Lo Overrun Valve

2007 Hummer H3

2007 TRANSMISSION Automatic Transmission - 4L60-E/4L65-E/4L70-E - H3

The PR fluid pressure moves the valve against the spring force and fills the Lo/reverse fluid circuit. Lo/reverse fluid is orificed (323) back to the lo overrun valve in order to assist the PR fluid in moving the valve against the spring force. The spring force provides a time delay for the PR fluid filling the Lo/reverse fluid circuit. The Lo/reverse fluid is routed to the inner area of the lo and reverse clutch piston in order to increase the holding capacity of the clutch.

Transmission Fluid Pressure (TFP) Manual Valve Position Switch Assembly

The TFP manual valve position switch consists of five fluid pressure switches: D2 and D3 are normally closed and D4, Lo and Rev are normally open. All fluid circuits routed to the assembly are empty and the TFP manual valve position switch signals the PCM that the transmission is in either Park or Neutral.

Shift Solenoid Valves (1-2 and 2-3)

Both shift solenoid valves, which are normally open, are energized by the PCM and block fluid from exhausting. This maintains the signal A fluid pressure at the 1-2 shift solenoid valve and signal B fluid pressure at the 2-3 shift solenoid valve.

Shift Valves (1-2, 2-3 and 3-4)

Signal A fluid pressure holds the 1-2 shift valve in the downshift position and the 3-4 valve in the upshift (first and fourth gear) position. The signal B fluid pressure from the 2-3 shift solenoid valve holds the 2-3 shift valve train in the downshift position.

2007 Hummer H3

2007 TRANSMISSION Automatic Transmission - 4L60-E/4L65-E/4L70-E - H3

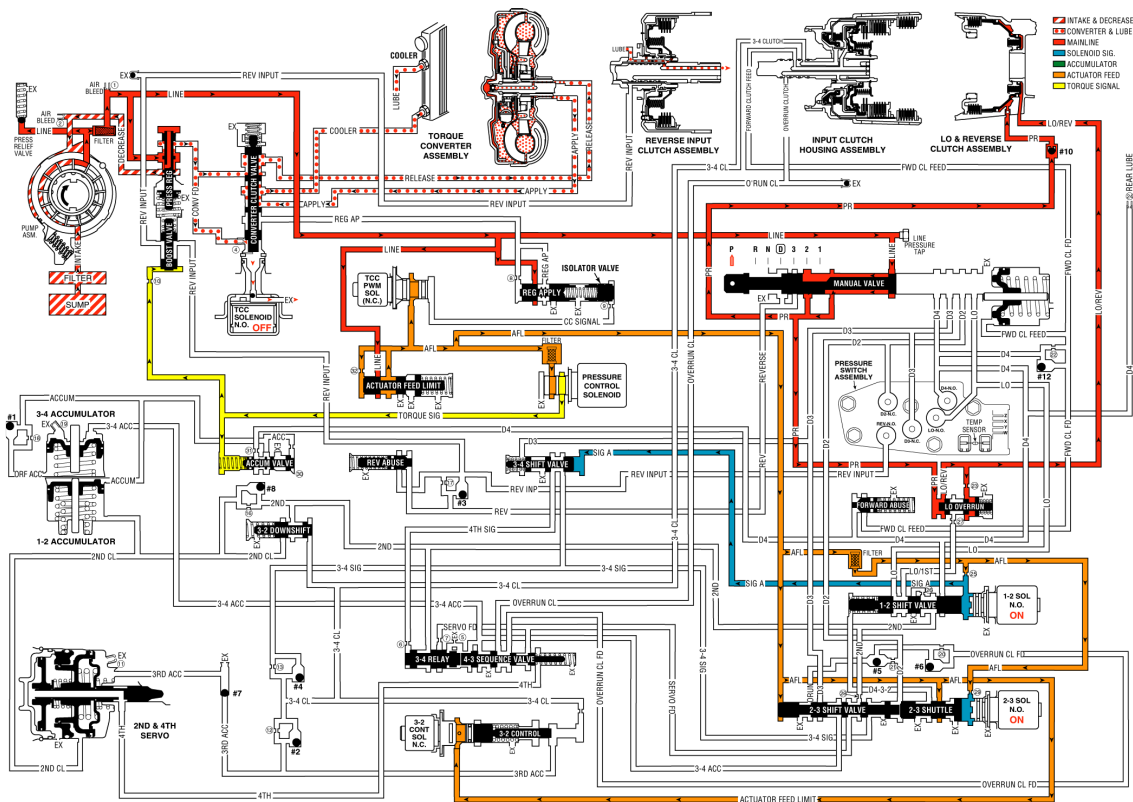

Fig. 486: Park - Engine Running Hydraulic Circuit Diagram
Courtesy of GENERAL MOTORS CORP.

REVERSE

When the gear selector lever is moved to the Reverse (R) position (from the Park position), the following changes occur to the transmissions hydraulic and electrical systems:

Manual Valve

The manual valve moves to the Reverse position and line pressure enters the reverse fluid circuit. As in Park, line pressure also fills the PR (Park/Reverse) fluid circuit. All other fluid circuits are blocked by the manual valve.

Lo and Reverse Clutch

As in Park, PR fluid pressure acts on the outer area of the lo and reverse clutch piston to apply the lo and reverse clutch. Also, Lo/reverse fluid from the lo overrun valve acts on the inner area of the piston to increase the holding capacity of the clutch (see Note below).

Reverse Input Checkball (#3)

Reverse fluid pressure seats the #3 checkball, flows through orifice #17 and fills the reverse input

2007 Hummer H3

2007 TRANSMISSION Automatic Transmission - 4L60-E/4L65-E/4L70-E - H3

fluid circuit. This orifice helps control the reverse input clutch apply rate when engine speed is at idle.

Reverse Abuse Valve

Reverse fluid pressure acts on the end of the valve opposite of spring force. At engine speeds above idle, reverse fluid pressure, which is fed by line pressure, increases and moves the valve against spring force (as shown). Reverse fluid can then fill the reverse input fluid circuit through the reverse abuse valve. This bypasses the control of orifice #17 and provides a faster clutch apply.

Boost Valve

Reverse input fluid pressure moves the boost valve against the pressure regulator valve spring. The spring acts on the pressure regulator valve to increase the operating range of line pressure in Reverse. Reverse input fluid also flows through the valve and to the reverse input clutch piston. Remember that torque signal fluid pressure continually acts on the boost valve to control line pressure in response to vehicle operating conditions.

Reverse Input Clutch Piston

Reverse input fluid pressure moves the piston to apply the reverse input clutch plates and obtain Reverse.

Reverse Input Air Bleed Checkball

This ball and capsule is located in the reverse input fluid circuit in the oil pump to provide an air escape when the fluid pressure increases. It also allows air into the circuit to displace the fluid when the clutch releases.

Transmission Fluid Pressure (TFP) Manual Valve Position Switch Assembly

Reverse input fluid pressure closes the normally open reverse switch in the TFP manual valve position switch. This signals the PCM that the manual valve is in the Reverse (R) position.

Shift Solenoid Valves (1-2 and 2-3)

Both shift solenoid valves are energized as in the Park range. Signal A and signal B fluids are blocked from exhausting through the shift solenoid valves to maintain fluid pressure in these circuits at the end of the shift valves.

Shift Valves (1-2, 2-3 and 3-4)

2007 Hummer H3

2007 TRANSMISSION Automatic Transmission - 4L60-E/4L65-E/4L70-E - H3

Signal A fluid pressure holds the 1-2 shift valve in the downshifted position and the 3-4 shift valve in the upshifted (First and Fourth gear) position. Signal B fluid pressure holds the 2-3 shift valve train in the downshifted position.

Pressure Control (PC) Solenoid Valve

The PC solenoid valve continues to regulate AFL fluid into torque signal fluid pressure. The PCM varies the current at the solenoid to regulate torque signal fluid pressure in response to throttle position and other PCM input signals. Torque signal fluid pressure is used to control line pressure at the boost and pressure regulator valves.

Note: The explanation in each gear range is, for the most part, limited.

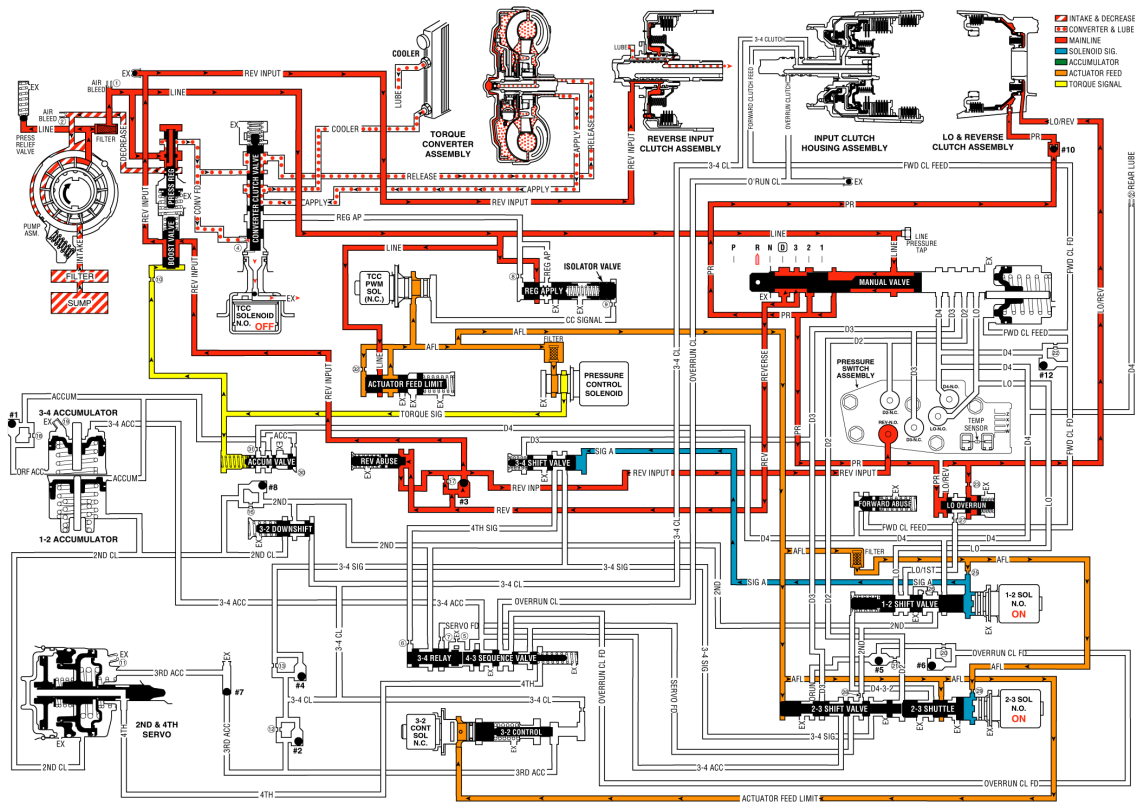

Fig. 487: Reverse Hydraulic Circuit Diagram
Courtesy of GENERAL MOTORS CORP.

NEUTRAL - ENGINE RUNNING

When the gear selector lever is moved to the Neutral position (N) from the Reverse position, the following changes occur to the transmission hydraulic and electrical systems.

Manual Valve

2007 Hummer H3

2007 TRANSMISSION Automatic Transmission - 4L60-E/4L65-E/4L70-E - H3

In the Neutral position, the manual valve blocks the line pressure from entering any other fluid circuits. Reverse and PR fluids exhaust past the manual valve.

Lo and Reverse Clutch Releases

Lo and Reverse Clutch Piston

PR and Lo/reverse fluids exhaust from the piston, thereby releasing the lo and reverse clutch plates. Exhausting PR fluid unseats the lo and reverse clutch checkball (#10) for a quick exhaust.

Lo Overrun Valve

Spring force closes the valve when the PR fluid pressure exhausts. Lo/reverse fluid exhausts through the valve, into the Lo/1st fluid circuit, past the 1-2 shift valve, into the Lo fluid circuit and through an exhaust port at the manual valve.

Reverse Input Clutch Releases

Reverse Input Clutch Piston

Reverse input fluid pressure exhausts from the piston, through the boost valve, past the #3 checkball and to the manual valve. With the reverse input fluid exhausted, the reverse input clutch plates are released and the transmission is in Neutral.

Reverse Abuse Valve

Reverse fluid pressure exhausts and spring force closes the valve.

Boost Valve

Reverse input fluid pressure exhausts and line pressure returns to the normal operating range as in the Park and Overdrive positions.

Reverse Input Checkball (#3)

Exhausting reverse input fluid unseats the ball for a quick exhaust through the reverse fluid circuit and past the manual valve.

Transmission Fluid Pressure (TFP) Manual Valve Position Switch Assembly

IMPORTANT: In Park, Reverse and Neutral the shift solenoid valves are shown energized. This is the normal operating state when the vehicle is stationary or at low vehicle speeds. However, the PCM will change the shift solenoid valve states depending on the vehicle

2007 Hummer H3

2007 TRANSMISSION Automatic Transmission - 4L60-E/4L65-E/4L70-E - H3

speed. For example, if Neutral is selected when the transmission is operating in Second Gear, the shift solenoid valves will remain in a Second Gear state. However, with the manual valve blocking line pressure, the shift solenoid valve states do not affect transmission operation in Park, Reverse and Neutral.

Reverse input fluid exhausts from the TFP manual valve position switch. With no other fluid routed to it, the TFP manual valve position switch signals the PCM that the transmission is operating in either Park or Neutral.

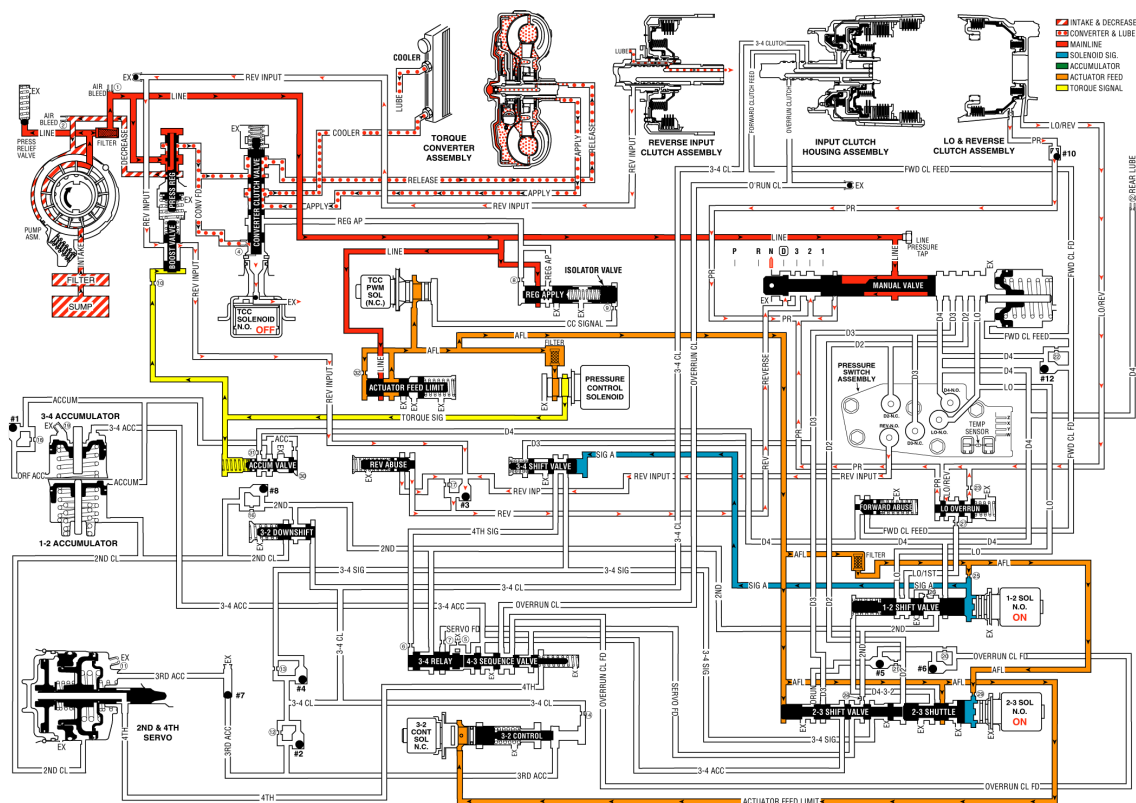

Fig. 488: Neutral - Engine Running Hydraulic Circuit Diagram
Courtesy of GENERAL MOTORS CORP.

OVERDRIVE RANGE, FIRST GEAR

When the gear selector lever is moved to the Overdrive position, from the neutral position, the following changes occur to the transmission's hydraulic and electrical systems:

Manual Valve

Line pressure flows through the manual valve and fills the D4 fluid circuit. All other fluid circuits remain empty with the manual valve in the Overdrive position.

2007 Hummer H3

2007 TRANSMISSION Automatic Transmission - 4L60-E/4L65-E/4L70-E - H3

Forward Clutch Accumulator Checkball (#12)

D4 fluid pressure seats the checkball and is orificed (#22) into the forward clutch feed fluid circuit. This orifice helps control the forward clutch apply rate.

Forward Clutch Accumulator Piston

Forward clutch feed fluid pressure moves the piston against spring force. This action absorbs some of the initial increase of forward clutch feed fluid pressure to cushion the forward clutch apply.

Forward Clutch Abuse Valve

D4 fluid pressure acts on the valve opposite of spring force. At engine speeds greater than idle, D4 fluid pressure increases and moves the valve against spring force (as shown). D4 fluid can then quickly fill the forward clutch feed fluid circuit, thereby bypassing the control of orifice #22 and providing a faster apply of the forward clutch. Otherwise, with increased throttle opening and engine torque, the clutch may slip during apply.

Transmission Fluid Pressure (TFP) Manual Valve Position Switch Assembly

D4 fluid pressure is routed to the TFP manual valve position switch and closes the normally open D4 fluid pressure switch. This signals the PCM that the transmission is operating in Overdrive range.

1-2 Shift Solenoid (SS) Valve

Energized (ON) as in Neutral, the normally open solenoid is closed and blocks signal A fluid from exhausting through the solenoid. This maintains pressure in the signal A fluid circuit.

2-3 Shift Solenoid (SS) Valve

Energized (ON) as in Neutral, the normally open solenoid is closed and blocks signal B fluid from exhausting through the solenoid. This maintains signal B fluid pressure at the solenoid end of the 2-3 shift valve.

2-3 Shift Valve Train

Signal B fluid pressure at the solenoid end of the 2-3 shift valve holds the valve train in the downshifted position against AFL fluid pressure acting on the 2-3 shift valve. In this position, the 2-3 shuttle valve blocks AFL fluid from entering the D432 fluid circuit. The D432 fluid circuit is open to an exhaust port past the valve.

1-2 Shift Valve

2007 Hummer H3

2007 TRANSMISSION Automatic Transmission - 4L60-E/4L65-E/4L70-E - H3

Signal A fluid pressure holds the valve in the downshifted position against spring force. In the First gear position, the valve blocks D4 fluid from entering the 2nd fluid circuit.

Accumulator Valve

Biased by torque signal fluid pressure, spring force and orificed accumulator fluid pressure at the end of the valve, the accumulator valve regulates D4 fluid into accumulator fluid pressure. Accumulator fluid is routed to both the 1-2 and 3-4 accumulator assemblies in preparation for the 1-2 and 3-4 upshifts respectively.

Rear Lube

D4 fluid is routed through an orifice cup plug (#24) in the rear of the transmission case to feed the rear lube fluid circuit.

Pressure Control (PC) Solenoid Valve

Remember that the PC solenoid valve continually varies torque signal fluid pressure in relation to throttle position and vehicle operating conditions. This provides a precise control of line pressure.

3-2 Control Solenoid Valve

The PCM keeps the solenoid OFF in First gear and the normally closed solenoid blocks filtered AFL fluid from entering the 3-2 signal fluid circuit.

Torque Converter Clutch PWM Solenoid Valve

In first gear, at approximately 6 mph, the PCM operates the TCC PWM solenoid valve at approximately a 90 percent duty cycle. This opens the AFL fluid circuit, to fill the converter clutch signal fluid circuit through the #9 orifice and flows to the isolator valve. The CC signal fluid pressure, acting on the isolator valve, will move the regulated apply valve towards the closed position. Regulated line pressure is now routed into the regulated apply circuit and flows to the closed converter clutch valve and is blocked from entering the converter clutch apply circuit. Regulated apply fluid is routed through the #8 orifice to the front of the regulated apply valve and regulates the line pressure entering the regulated apply circuit, in response to the CC signal fluid acting on the isolator valve.

2007 Hummer H3

2007 TRANSMISSION Automatic Transmission - 4L60-E/4L65-E/4L70-E - H3

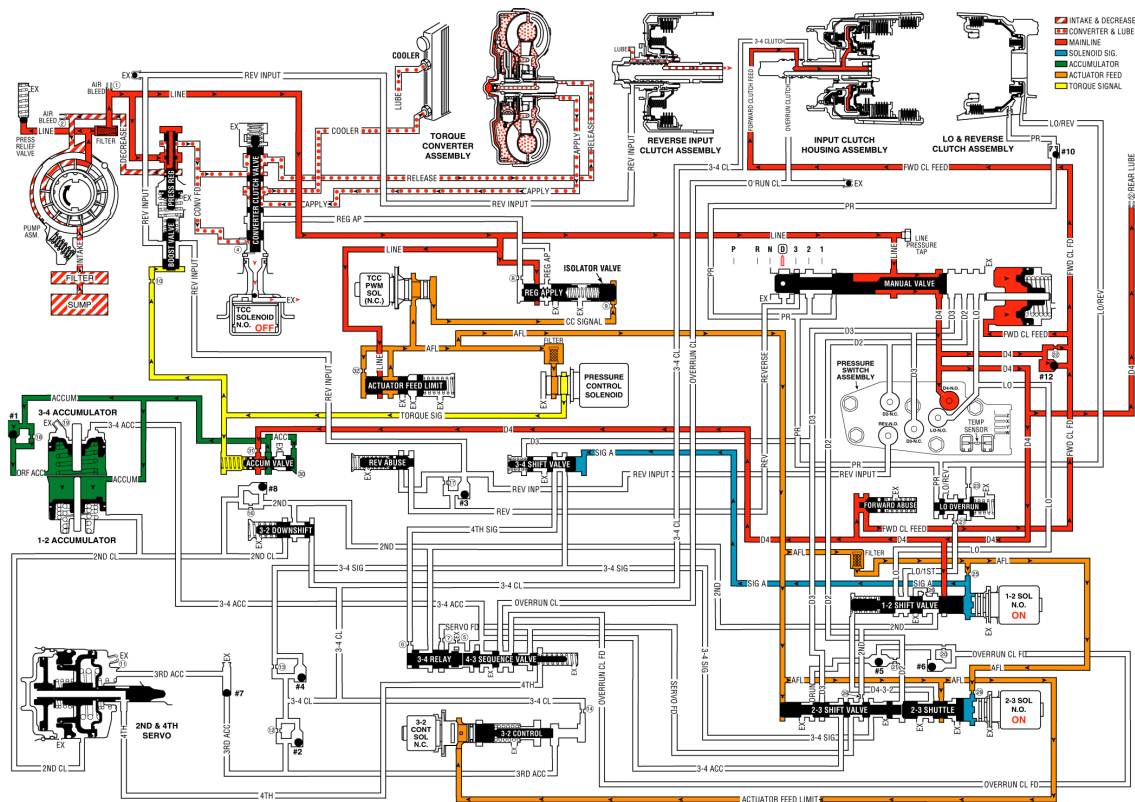

Fig. 489: Overdrive Range, First Gear Hydraulic Circuit Diagram
Courtesy of GENERAL MOTORS CORP.

OVERDRIVE RANGE, SECOND GEAR

As vehicle speed increases and other operating conditions are appropriate, the PCM de-energizes the 1-2 shift solenoid valve in order to shift the transmission to second gear.

1-2 Shift Solenoid (SS) Valve

De-energized (turned OFF) by the PCM, the normally open solenoid opens and signal A fluid exhausts through the solenoid.

2-3 Shift Solenoid (SS) Valve

IMPORTANT: The actuator feed limit (AFL) fluid continues to feed the signal A fluid circuit through orifice #25. However, the exhaust port through the solenoid is larger than orifice #25 in order to prevent a pressure buildup in the signal A fluid circuit. Exhausting signal A fluid is represented by the blue arrows.

Energized (ON) as in first gear, the 2-3 shift solenoid valve blocks signal B fluid from exhausting

2007 Hummer H3

2007 TRANSMISSION Automatic Transmission - 4L60-E/4L65-E/4L70-E - H3

through the solenoid. This maintains signal B fluid pressure at the solenoid end of the 2-3 shift valve.

1-2 Shift Valve

Without signal A fluid pressure, spring force moves the valve into the upshift position. D4 fluid is routed through the valve and fills the 2nd fluid circuit.

1-2 Shift Checkball (#8)

The 2nd fluid pressure seats the #8 checkball, flows through orifice #16 and fills the 2nd clutch fluid circuit. This orifice helps control the 2-4 band apply rate.

2-4 Servo Assembly

The 2nd clutch fluid pressure moves the #8 checkball, flows through orifice #16 and fills the 2nd clutch fluid circuit. This orifice helps to control the 2-4 band apply rate.

1-2 Accumulator

The 2nd clutch fluid pressure also moves the 1-2 accumulator piston against the spring force and the accumulator fluid pressure. This action absorbs the initial 2nd clutch fluid pressure in order to cushion the 2-4 band apply rate. Also, the movement of the 1-2 accumulator piston forces some accumulator fluid out of the accumulator assembly. This accumulator fluid is routed back to the accumulator valve.

Accumulator Valve

The accumulator fluid forced out of the 1-2 accumulator is orificed (#30) to the end of the accumulator valve. This pressure moves the valve against the spring force and the torque signal fluid pressure in order to regulate the exhaust of excess accumulator fluid. This regulation provides additional control for the 2-4 band apply rate. The fluid circuit shows the exhaust of the accumulator fluid during the shift by the arrow directions in the accumulator fluid circuit.

2-3 Shift Valve Train

The signal B fluid pressure from the 2-3 shift solenoid valve holds the valve train in the downshift position. The 2nd fluid is routed through the 2-3 shuttle valve and fills the servo feed fluid circuit.

3-4 Relay Valve and 4-3 Sequence Valve

Spring force holds these valves in the downshift position (first, second and third gear positions). The 2nd fluid is blocked by the 3-4 relay valve and the servo feed fluid is blocked by both valves

2007 Hummer H3

2007 TRANSMISSION Automatic Transmission - 4L60-E/4L65-E/4L70-E - H3

in preparation for a 3-4 upshift.

3-2 Downshift Valve

Spring force holds the valve closed, blocking the 2nd fluid and the 2nd clutch fluid. This valve is used in order to help control the 3-2 downshift.

3-2 Control Solenoid Valve

In second gear, the PCM energizes the normally closed solenoid. This opens the AFL fluid circuit to fill the 3-2 signal fluid circuit.

3-2 Control Valve

The 3-2 signal fluid pressure moves the valve against the spring force. This action does not affect the transmission operation in second gear.

3-4 Shift Valve

Signal A fluid pressure exhausts and spring force moves the valve into the downshift position (second and third gear positions).

Torque Converter Clutch

TCC Solenoid Valve

Under normal operating conditions, in Overdrive Range-Second Gear, the PCM keeps the normally open TCC solenoid valve de-energized. Converter feed fluid exhausts through the open solenoid and spring force keeps the converter clutch apply valve in the release position.

2007 Hummer H3

2007 TRANSMISSION Automatic Transmission - 4L60-E/4L65-E/4L70-E - H3

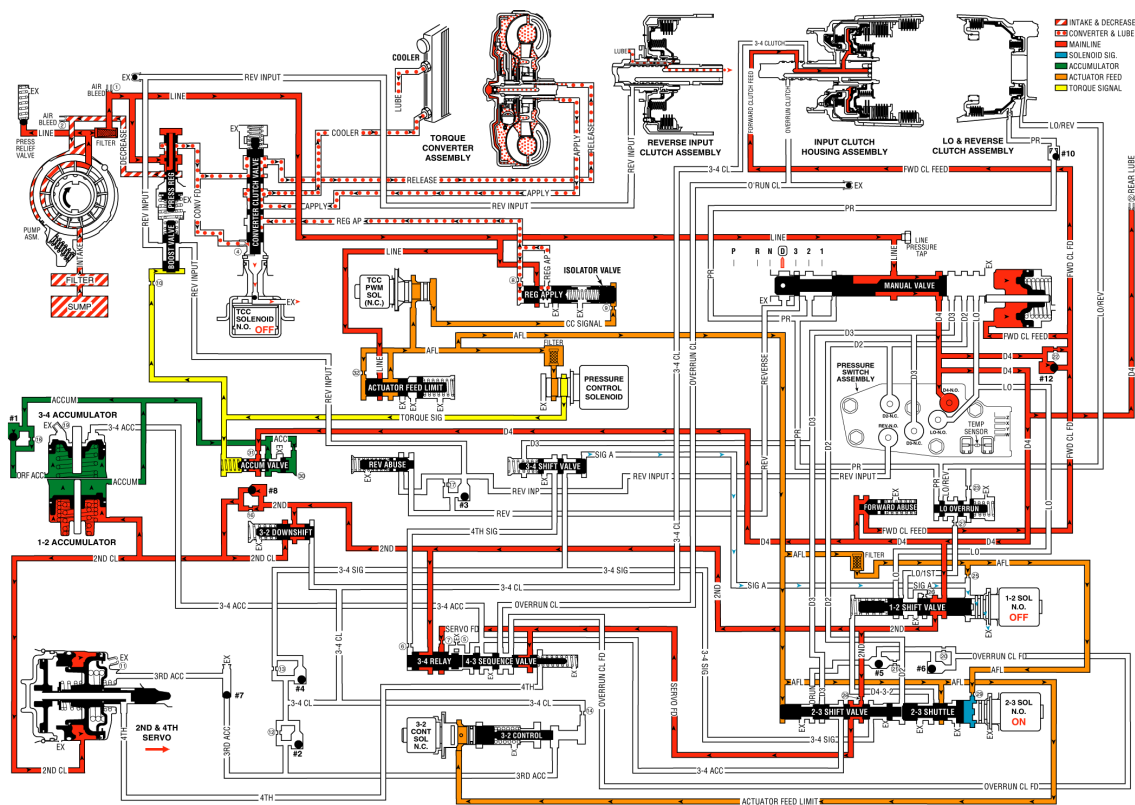

Fig. 490: Overdrive Range, Second Gear Hydraulic Circuit Diagram
Courtesy of GENERAL MOTORS CORP.

OVERDRIVE RANGE, THIRD GEAR

As vehicle speed increases further and other vehicle operating conditions are appropriate, the PCM de-energizes the normally open 2-3 shift solenoid valve in order to shift the transmission into Third gear.

2-3 Shift Solenoid (SS) Valve

De-energized (turned OFF) by the PCM, the solenoid opens and actuator feed limit signal B fluid exhausts through the solenoid.

Note: AFL fluid continues to feed signal B fluid to the solenoid through orifice #29. However, the exhaust port through the solenoid is larger than orifice #29 to prevent a buildup of pressure in the signal B fluid circuit at the solenoid end of the 2-3 shift valve. Exhausting signal B fluid is represented by the arrows through the solenoid.

2-3 Shift Valve Train

AFL fluid pressure at the 2-3 shift valve moves the valve train toward the solenoid. In the

upshifted position, the following changes occur:

- AFL fluid is routed through the 2-3 shift valve and fills the D432 fluid circuit.
- 2nd fluid is blocked from entering the servo feed fluid circuit and is orificed (#28) into the 3-4 signal fluid circuit. This orifice helps control the 3-4 clutch apply rate.
- Servo feed fluid exhausts past the valve into the 3-4 accumulator fluid circuit and through an exhaust port at the 3-4 relay valve.

3-4 Clutch Exhaust Checkball (#4)

3-4 signal fluid unseats the ball and enters the 3-4 clutch fluid circuit.

3-4 Clutch Piston

3-4 clutch fluid pressure moves the piston to apply the 3-4 clutch plates and obtain 3rd gear. However, the 2-4 band must release as the 3-4 clutch applies.

3rd Accumulator Checkball (#2)

3-4 clutch fluid pressure unseats the ball and fills the 3rd accumulator fluid circuit.

3rd Accumulator Exhaust Checkball (#7)

3rd accumulator fluid seats the ball against the orificed exhaust and is routed to the released side of the 2nd apply piston. Before the #7 checkball seats, air in the 3rd accumulator fluid circuit is exhausted through the orifice.

2-4 Servo Assembly

3rd accumulator fluid pressure acts on the release side of the 2nd apply piston and assists servo return spring force. The surface area on the release side of the piston is greater than the surface area on the apply side. Therefore, 3rd accumulator fluid pressure and servo return spring force move the 2nd apply piston against 2nd clutch fluid pressure. This action serves two functions:

- Move the apply pin to release the 2-4 band.
- Act as an accumulator by absorbing initial 3-4 clutch fluid to cushion the 3-4 clutch apply rate. Remember that the 3rd accumulator fluid circuit is fed by 3-4 clutch fluid.

3-2 Downshift Valve

3-4 clutch fluid pressure moves the valve against spring force. This opens the valve and allows 2nd fluid to feed the 2nd clutch fluid circuit through the valve.

2007 Hummer H3

2007 TRANSMISSION Automatic Transmission - 4L60-E/4L65-E/4L70-E - H3

3-2 Control Solenoid Valve and 3-2 Control Valve

The solenoid remains open and routes AFL fluid into the 3-2 signal fluid circuit. 3-2 signal fluid pressure holds the 3-2 control valve against spring force, thereby blocking the 3rd accumulator and 3-4 clutch fluid circuits.

1-2 Shift Solenoid (SS) Valve and 1-2 Shift Valve

The 1-2 SS valve remains de-energized and signal A fluid is exhausted through the solenoid. Also, D432 fluid pressure from the 2-3 shift valve assists spring force to hold the 1-2 shift valve in the upshifted position.

3-4 Shift Valve

Spring force holds the valve in the downshifted position, blocking 3-4 clutch fluid in preparation for a 3-4 upshift.

Torque Converter Clutch

TCC Solenoid Valve

Under normal operating conditions, in Overdrive Range-Third Gear, the PCM keeps the normally open TCC solenoid valve de-energized. Converter feed fluid exhausts through the open solenoid and spring force keeps the converter clutch apply valve in the release position. However, at speeds above approximately 121 km/h (75 mph), with the transmission still in third gear, the PCM will command TCC apply in third gear. Refer to **Overdrive Range, Fourth Gear - Torque Converter Clutch Applied** for more information on TCC apply.

2007 Hummer H3

2007 TRANSMISSION Automatic Transmission - 4L60-E/4L65-E/4L70-E - H3

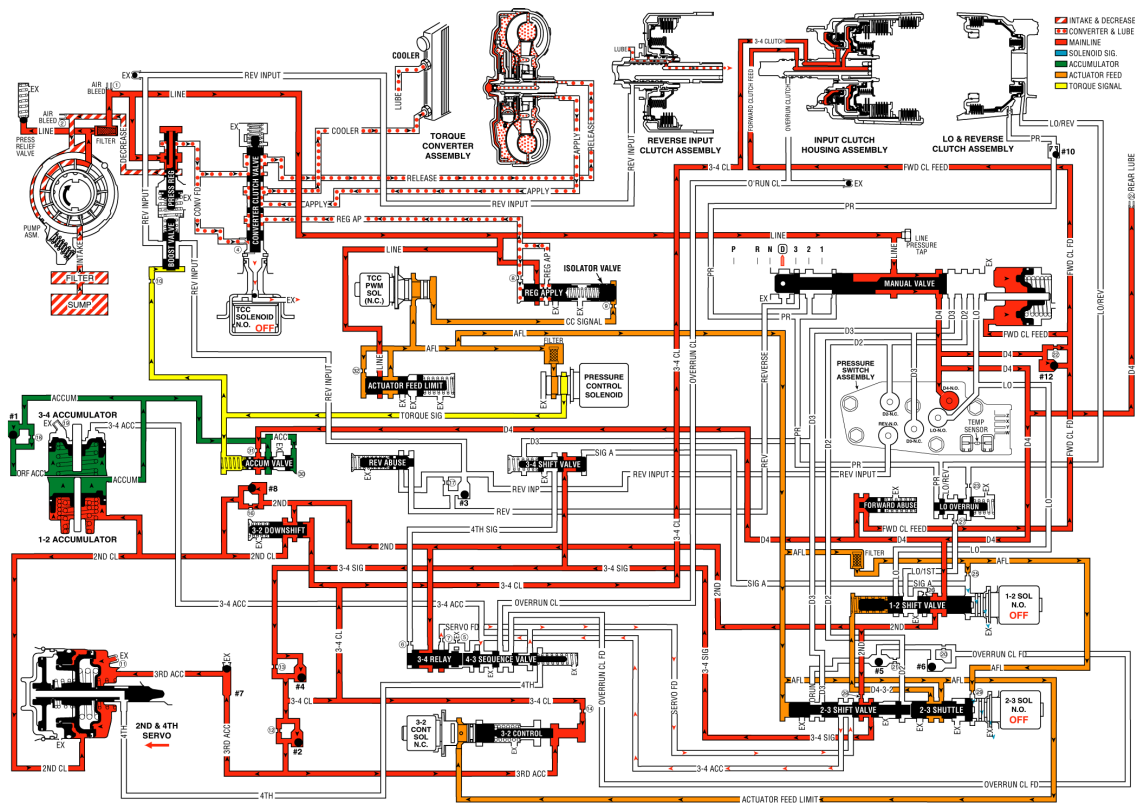

Fig. 491: Overdrive Range, Third Gear Hydraulic Circuit Diagram
Courtesy of GENERAL MOTORS CORP.

OVERDRIVE RANGE, FOURTH GEAR - TORQUE CONVERTER CLUTCH APPLIED

At higher vehicle speeds, the Hydra-matic 4L60-E transmission uses an overdrive gear ratio (fourth gear) in order to increase fuel economy and in order to maximize engine performance. When vehicle operating conditions are appropriate, the PCM energizes the 1-2 shift solenoid valve to shift the transmission into fourth gear.

1-2 Shift Solenoid (SS) Valve

Energized (turned ON) by the PCM, the normally open solenoid closes and blocks signal A fluid from exhausting through the solenoid. This creates pressure in the signal A fluid circuit.

2-3 Shift Solenoid (SS) Valve

De-energized (OFF) as in third gear, the 2-3 shift solenoid valve exhausts signal B fluid through the solenoid.

1-2 Shift Valve

D432 fluid pressure from the 2-3 shift valve and spring force hold the valve in the upshift position

against signal A fluid pressure.

3-4 Shift Valve

Signal A fluid pressure moves the valve into the upshift position against the spring force. In this position, the valve routes 3-4 signal fluid into the 4th signal fluid circuit.

3-4 Relay Valve and 4-3 Sequence Valve

4th signal fluid pressure moves both valves into the upshift (fourth gear) position against the spring force acting on the 4-3 sequence valve. This causes the following changes:

- Orificed (#7) 2nd fluid is routed through the 3-4 relay valve and into the servo feed fluid circuit.
- Servo feed fluid is routed through the 4-3 sequence valve and into the 4th fluid circuit.
- 3-4 accumulator fluid routed from the 2-3 shuttle valve is blocked by both valves.

2-4 Servo Assembly

4th fluid is routed through the center of the servo apply pin and acts on the apply side of the 4th apply piston. 4th fluid pressure moves the 4th apply piston against the apply pin spring force acting on the release side of the 4th apply piston. This action moves the apply pin and applies the 2-4 band in order to obtain fourth gear.

2-4 Band Apply Accumulation

2-3 Shift Valve Train

The valve train remains in the upshift position with the AFL fluid pressure acting on the 2-3 shift valve. In addition to its operation third gear, the 2-3 shift valve directs servo feed fluid into the 3-4 accumulator fluid circuit.

3-4 Accumulator Assembly

3-4 accumulator fluid pressure moves the 3-4 accumulator piston against spring force and orificed accumulator fluid pressure. This action absorbs initial 4th clutch apply fluid pressure in order to cushion the 2-4 band apply. Remember that both of the 3-4 accumulator and 4th fluid circuits are fed by servo feed fluid. As 3-4 accumulator fluid fills the accumulator, any air in the system will exhaust through office #19. This piston movement forces some orificed accumulator fluid out of the 3-4 accumulator assembly.

3-4 Accumulator Checkball (#1)

2007 Hummer H3

2007 TRANSMISSION Automatic Transmission - 4L60-E/4L65-E/4L70-E - H3

The accumulator fluid forced from the accumulator unseats the #1 checkball and enters the accumulator fluid circuit. This fluid is routed to the accumulator valve. This is shown by the arrow directions in the fluid circuit.

Accumulator Valve

Accumulator fluid forced from the 3-4 accumulator is orificed to the end of the accumulator valve. This fluid pressure, in addition to spring force and torque signal fluid pressure, regulates the exhaust of excess accumulator fluid pressure through the middle of the valve. This regulation helps control the 2-4 band apply feel.

3-2 Control Solenoid Valve and 3-2 Control Valve

The solenoid remains open and routes AFL fluid into the 3-2 signal fluid circuit. 3-2 signal fluid pressure holds the 3-2 control valve against spring force, thereby blocking the 3rd accumulator and 3-4 clutch fluid circuits.

Torque Converter Clutch Applies

TCC Solenoid Valve

When operating conditions are appropriate, the PCM energizes the normally open TCC solenoid valve. This closes the solenoid, blocks the converter feed fluid from exhausting and creates pressure in the converter feed fluid circuit at the converter clutch apply valve and TCC solenoid valve.

Converter Clutch Apply Valve

Converter feed fluid pressure moves the valve against spring force and into the apply position. In this position, release fluid is open to an exhaust port and regulated apply fluid fills the apply fluid circuit. Converter feed fluid is routed through the converter clutch apply valve to feed the cooler fluid circuit.

Torque Converter

Release fluid from behind the pressure plate exhausts through the end of the turbine shaft. Apply fluid pressure is routed between the converter hub and stator shaft where it enters the torque converter. This fluid applies the converter clutch against the converter cover and keeps the converter filled with fluid.

TCC Apply Checkball (#9)

Release fluid, exhausting from the converter, seats the #9 checkball located in the end of the

2007 Hummer H3

2007 TRANSMISSION Automatic Transmission - 4L60-E/4L65-E/4L70-E - H3

turbine shaft and is orificed around the ball. Orificing the exhausting release fluid controls the converter clutch apply rate, along with the TCC PWM solenoid valve.

TCC PWM Solenoid Valve

The torque converter clutch pulse width modulation (TCC PWM) solenoid valve controls the regulated apply valve position. This is done through the use of pulse width modulation (duty cycle operation). The solenoid duty cycle is controlled by the PCM in relation to vehicle operating conditions and regulates actuator feed limit (AFL) fluid into the CC signal circuit, through the #9 orifice and to the isolator valve. This controls line pressure flow through the regulated apply valve, into the regulated apply circuit and provides a smooth engagement of the TCC.

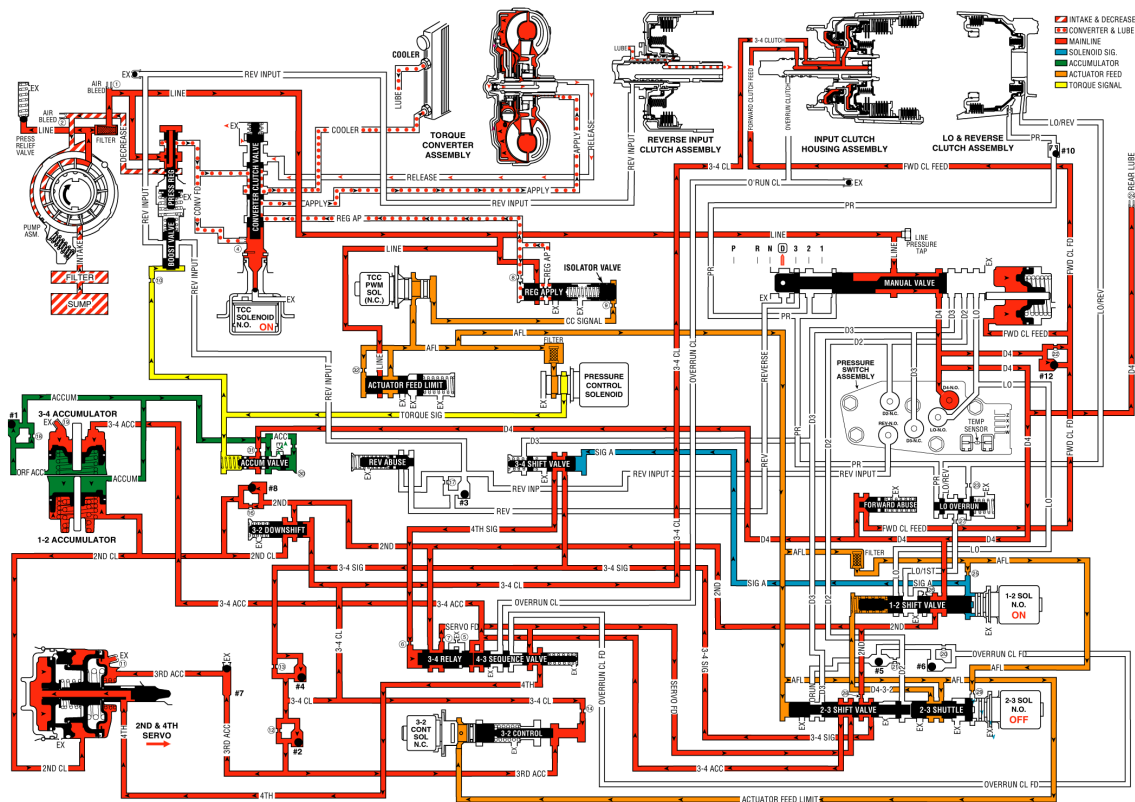

Fig. 492: Overdrive Range, Fourth Gear - TCC Applied Hydraulic Circuit Diagram
Courtesy of GENERAL MOTORS CORP.

OVERDRIVE RANGE, 4-3 DOWNSHIFT

When the transmission is operating in fourth gear, a forced 4-3 downshift occurs if there is a significant increase in throttle position. At minimum throttle, the vehicle speed decreases gradually (coastdown) and the PCM commands a 4-3 downshift. The PCM also initiates a forced 4-3 downshift when the throttle position remains constant but engine load is increased, such as

driving up a steep incline. To achieve a 4-3 downshift, the PCM de-energizes the 1-2 shift solenoid valve and the following changes occur to the transmission's electrical and hydraulic systems:

1-2 Shift Solenoid (SS) Valve

De-energized by the PCM, the normally open solenoid opens and signal A fluid exhausts through the solenoid.

1-2 Shift Valve

As in Fourth gear, D432 fluid pressure and spring force hold the valve in the upshift position.

2-4 Band Releases

3-4 Shift Valve

With the signal A fluid pressure exhausted, the spring force moves the valve into the downshift position. In this position, the valve blocks the 3-4 signal fluid and the 4th signal fluid exhausts past the valve.

3-4 Relay Valve and 4-3 Sequence Valve

These valves control the timing of the 2-4 band release. With the 4th signal fluid pressure exhausted, the 3-4 accumulator fluid pressure moves the 3-4 relay valve into the third gear position. This opens the 3-4 accumulator fluid to an orificed exhaust (#5) past the 3-4 relay valve (shown by red arrows). Because the exhaust is orificed, the 3-4 accumulator fluid pressure momentarily holds the 4-3 sequence valve against spring force before completely exhausting.

When the exhausting 3-4 accumulator fluid pressure decreases sufficiently, the spring force moves the 4-3 sequence valve into the third gear position as shown. This opens both the 3-4 accumulator and the 4th fluid circuits to a quick exhaust past the 4-3 sequence valve. In this position the valve blocks the 2nd fluid from entering the servo feed fluid circuit.

2-4 Servo Assembly

The 4th fluid exhausts from the 4th apply piston in the servo assembly. The apply pin spring moves the 4th apply piston and the apply pin in order to release the band from the reverse input drum and shift the transmission into third gear.

3-4 Accumulator Assembly

The 3-4 accumulator fluid exhausts from the 3-4 accumulator piston. The orificed accumulator

fluid pressure and the spring force move the piston into a third gear position.

3-4 Accumulator Checkball (#1)

As the accumulator fluid fills the 3-4 accumulator, it seats the #1 checkball and is forced through orifice #18. This orifice controls the rate at which accumulator fluid pressure fills the 3-4 accumulator and the 3-4 accumulator fluid exhausts from the accumulator assembly.

Accumulator Valve

Biased by torque signal fluid pressure and spring force, the accumulator valve regulates the D-4 fluid into the accumulator fluid circuit.

2-3 Shift Solenoid (SS) Valve

This solenoid remains de-energized as in fourth gear and the signal B fluid exhausts through the solenoid.

2-3 Shift Valve Train

The AFL fluid pressure at the 2-3 shift valve holds the valves in the upshift position. This allows the servo feed fluid to exhaust through the valve, into the 3-4 accumulator fluid circuit and past the 4-3 sequence valve.

Torque Converter Clutch Solenoid Valve

TCC PWM Solenoid Valve

The PCM de-energizes the TCC solenoid valve and operates the duty cycle of the TCC PWM solenoid valve to release the converter clutch for a smooth disengagement, prior to initiating the 4-3 downshift.

Pressure Control (PC) Solenoid Valve

Remember that the PC solenoid valve continually adjusts the torque signal fluid pressure in relation to the various PCM input signals (mainly the throttle position).

2007 Hummer H3

2007 TRANSMISSION Automatic Transmission - 4L60-E/4L65-E/4L70-E - H3

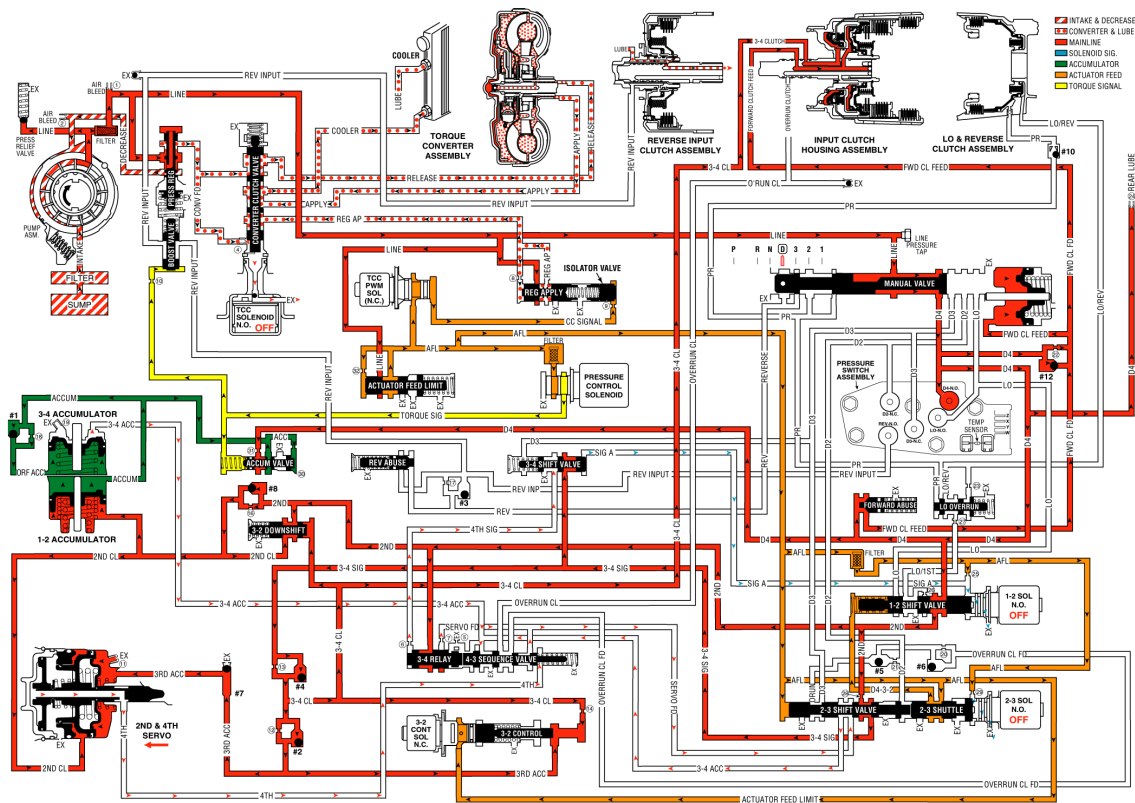

Fig. 493: Overdrive Range, 4-3 Downshift Hydraulic Circuit Diagram
Courtesy of GENERAL MOTORS CORP.

OVERDRIVE RANGE, 3-2 DOWNSHIFT

Similar to a forced 4-3 downshift, a forced 3-2 downshift can occur because of minimum throttle (coastdown conditions), heavy throttle or increased engine load. In order to achieve a forced 3-2 downshift, the PCM energizes the 2-3 shift solenoid valve and the following changes occur:

Energized by the PCM, the normally open solenoid closes and blocks the signal B fluid from exhausting through the solenoid. This creates pressure in the signal B fluid circuit at the solenoid end of the 2-3 shift valve.

2-3 Shift Valve Train

The signal B fluid pressure from the shift solenoid moves both valves to the downshift position against AFL fluid pressure acting on the 2-3 shift valve. This causes the following changes:

- The AFL fluid is blocked from the D432 fluid circuit and the D432 fluid exhausts past the 2-3 shuttle valve.
- The 2nd fluid is blocked from feeding the 3-4 signal fluid circuit and the 2nd fluid is routed into the servo feed fluid circuit.

2007 Hummer H3

2007 TRANSMISSION Automatic Transmission - 4L60-E/4L65-E/4L70-E - H3

- The 3-4 signal fluid is exhausted past the valve. The 3-4 clutch fluid and the 3rd accumulator fluid, which were fed by the 3-4 signal fluid, also exhaust.

3-4 Clutch Releases and 2-4 Band Applies

3-4 Clutch Piston

The 3-4 clutch fluid exhausts from the piston and the 3-4 clutch plates are released.

3-4 Clutch Exhaust Checkball (#4)

Exhausting 3-4 clutch fluid seats the #4 checkball and is forced through orifice #13. This orifice controls the 3-4 clutch fluid exhaust and the 3-4 clutch release rate.

2-4 Servo Assembly

The 3rd accumulator fluid exhausts from the servo assembly. The 2nd clutch fluid pressure moves the 2nd apply piston against the servo return spring force in order to move the apply pin and apply the 2-4 band.

3-2 Downshift Valve and 1-2 Upshift Checkball (#8)

The 3-4 clutch fluid exhausts from the valve and the spring force moves the valve into the second gear position. However, before the spring force overcomes the exhausting 3-4 clutch fluid pressure, the 2nd fluid feeds the 2nd clutch fluid circuit through the valve. This bypasses the control of orifice #16 at the #8 checkball and provides a faster 2-4 band apply. Remember that the #8 checkball and orifice #16 are used to help control the 2-4 band apply during a 1-2 upshift.

Downshift Timing and Control

At higher vehicle speeds, the 2-4 band apply must be delayed to allow the engine speed RPM to increase sufficiently for a smooth transfer of engine load to the 2-4 band. Therefore, exhaust of the 3rd accumulator fluid must be delayed. However, at lower speeds the band must be applied quickly. In order to provide for the varying requirements for the 2-4 band apply rate, the exhausting 3rd accumulator fluid is routed to both the 3rd accumulator checkball (#2) and the 3-2 control valve.

3rd Accumulator Checkball (#2)

The exhausting 3rd accumulator fluid seats the #2 checkball and is forced through orifice #12. This fluid exhausts through the 3-4 clutch and the 3-4 signal fluid circuits and past the 2-3 shift valve. Orifice #12 slows the exhaust of the 3rd accumulator fluid and delays the 2-4 band apply rate.

3-2 Control Solenoid Valve and 3-2 Control Valve

These components are used to increase the exhaust rate of 3rd accumulator fluid, as needed, depending on the vehicle speed.

The 3-2 control solenoid valve is a normally closed On/Off solenoid controlled by the PCM. The PCM controls the solenoid state during a 3-2 downshift according to vehicle speed.

Low Speed

- At lower vehicle speeds, the PCM operates the 3-2 control solenoid valve in the Off position.
- In the Off position the solenoid blocks actuator feed limit fluid pressure from the 3-2 control valve.
- With no actuator feed limit fluid pressure, the 3-2 control valve spring force keeps the valve open to allow a faster exhaust of 3rd accumulator fluid through orifice #14 into the 3-4 clutch fluid circuit.
- A faster exhaust of the 3rd accumulator exhaust fluid provides a faster apply of the 2-4 band, as needed at lower vehicle speeds.

High Speed

- At high vehicle speed, the PCM operates the 3-2 control solenoid valve in the On position allowing actuator feed limit fluid to pass through the solenoid. This pushes the 3-2 control valve into the closed position.
- This action permits a slow apply of the 2-4 band by blocking off 3rd accumulator exhaust fluid from entering the 3-4 clutch fluid circuit through orifice #14.
- This allows the engine speed to easily come up to the necessary RPM before the 2-4 band is applied.

3rd Accumulator Exhaust Checkball (#7)

After the downshift is completed, the #7 checkball unseats and allows the residual fluid in the 3rd accumulator fluid circuit to exhaust.

Pressure Control (PC) Solenoid Valve

Remember that the PC solenoid valve continually adjusts torque signal fluid in relation to the various PCM input signals (mainly the throttle position).

2007 Hummer H3

2007 TRANSMISSION Automatic Transmission - 4L60-E/4L65-E/4L70-E - H3

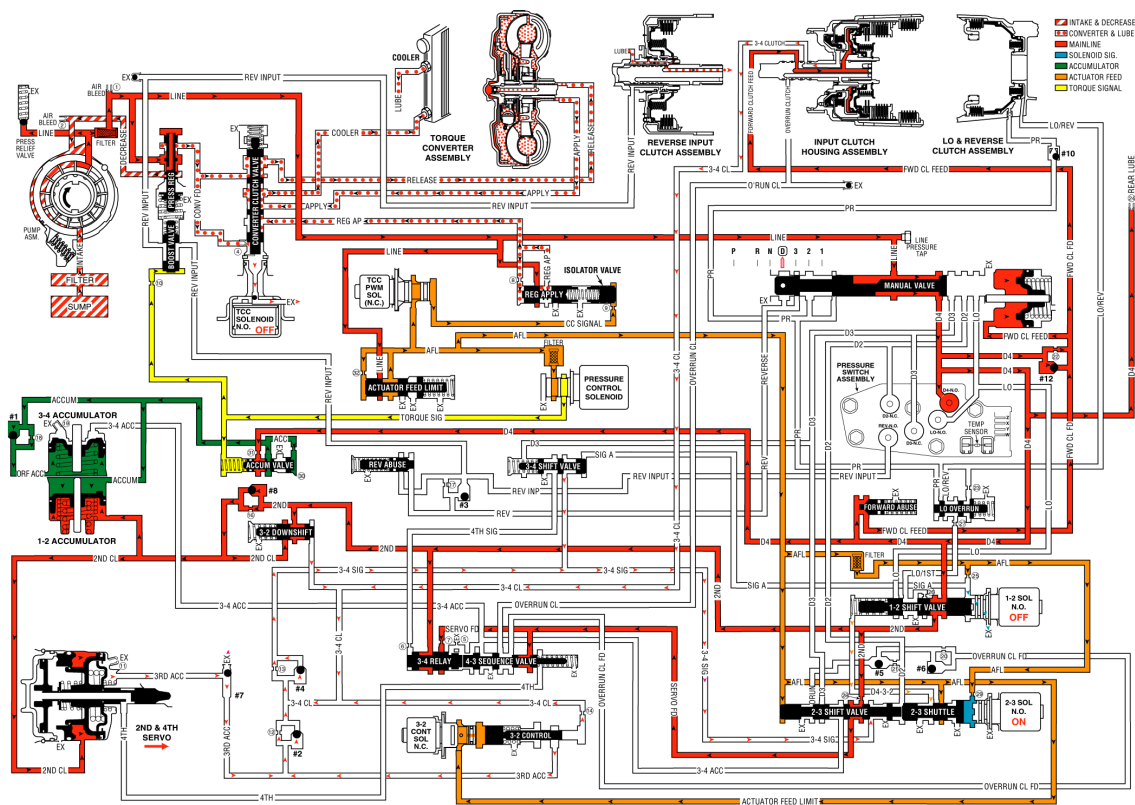

Fig. 494: Overdrive Range, 3-2 Downshift Hydraulic Circuit Diagram
Courtesy of GENERAL MOTORS CORP.

MANUAL THIRD GEAR

A manual 4-3 downshift is available to increase vehicle performance when the use of only three gear ratios is desired. Manual Third gear range also provides engine braking in Third gear when the throttle is released. A manual 4-3 downshift is accomplished by moving the selector lever into the Manual Third (D) position. This moves the manual valve and immediately downshifts the transmission into Third gear. Refer to **Overdrive Range, 4-3 Downshift** for a complete description of a 4-3 downshift. In Manual Third, the transmission is prevented, both hydraulically and electronically, from shifting into Fourth gear. The following information explains the additional changes during a manual 4-3 downshift as compared to a forced 4-3 downshift.

Manual Valve

The selector lever moves the manual shaft and manual valve into the Manual Third position (D). This allows line pressure to enter the D3 fluid circuit.

Transmission Fluid Pressure (TFP) Manual Valve Position Switch Assembly

D3 fluid is routed to the TFP manual valve position switch and opens the normally closed D3

2007 Hummer H3

2007 TRANSMISSION Automatic Transmission - 4L60-E/4L65-E/4L70-E - H3

fluid pressure switch. The combination of the opened D3 switch and the closed D4 switch signals the PCM that the transmission is operating in Manual Third.

1-2 Shift Solenoid (SS) Valve

When Manual Third is selected, the PCM de-energizes the 1-2 SS valve to immediately downshift the transmission into Third gear. This electronically prevents Fourth gear.

3-4 Shift Valve

D3 fluid pressure assists spring force to keep the valve in the downshifted position against the signal A fluid circuit. In this position, the valve blocks 3-4 signal fluid and the 4th signal fluid circuit is open to an exhaust port past the valve. Therefore, with D3 fluid pressure assisting spring force, Fourth gear is hydraulically prevented.

2-3 Shift Valve Train

With the 2-3 SS valve de-energized and open, actuator feed limit (AFL) fluid acting on the 2-3 shift valve holds both valves in the upshifted position. This allows D3 fluid to feed the overrun fluid circuit through the 2-3 shift valve.

Overrun Clutch Feed Checkball (#5)

Overrun fluid pressure seats the ball against the empty D2 fluid circuit.

Overrun Clutch Control Checkball (#6)

Overrun fluid pressure seats the #6 checkball and is orificed (#20) to fill the overrun clutch feed fluid circuit. This orifice controls the overrun clutch apply rate.

3-4 Relay Valve and 4-3 Sequence Valve

4th signal fluid pressure is exhausted from the end of the 3-4 relay valve. Overrun clutch feed fluid pressure assists spring force and closes both valves. This allows overrun clutch feed fluid to flow through the 4-3 sequence valve and fill the overrun clutch fluid circuit.

Overrun Clutch Piston

Overrun clutch fluid pressure moves the piston to apply the overrun clutch plates. The overrun clutch plates provide engine compression braking in Manual Third - Third Gear.

Overrun Clutch Air Bleed Checkball

This ball and capsule is located in the overrun clutch fluid circuit in the oil pump. It allows air to

2007 Hummer H3

2007 TRANSMISSION Automatic Transmission - 4L60-E/4L65-E/4L70-E - H3

exhaust from the circuit as fluid pressure increases and also allows air into the circuit to displace the fluid when the clutch releases.

Torque Converter Clutch and Torque Converter Clutch PWM Solenoid Valve

The PCM de-energizes the TCC solenoid valve and operates the duty cycle of the TCC PWM solenoid valve to release the converter clutch prior to downshifting, (assuming the converter clutch is applied in Overdrive Range-Fourth Gear when Manual Third is selected). The PCM will re-apply the converter clutch in Manual Third-Third Gear when proper driving conditions have been met.

Pressure Control (PC) Solenoid Valve

The PC solenoid valve operates in the same manner as Overdrive Range, regulating in response to throttle position and other vehicle operating conditions.

Manual Third - First and Second Gears: Overrun Clutch Released

In Manual Third, the transmission upshifts and downshifts normally between First, Second and Third gears. However, in First and Second gears, the 2-3 SS valve is energized and the 2-3 shift valve train is in the downshifted position. The 2-3 shift valve blocks D3 fluid from entering the overrun fluid circuit and opens the overrun fluid circuit to an exhaust port at the valve. This prevents overrun clutch apply and engine compression braking in Manual Third-First and Second Gears.

2007 Hummer H3

2007 TRANSMISSION Automatic Transmission - 4L60-E/4L65-E/4L70-E - H3

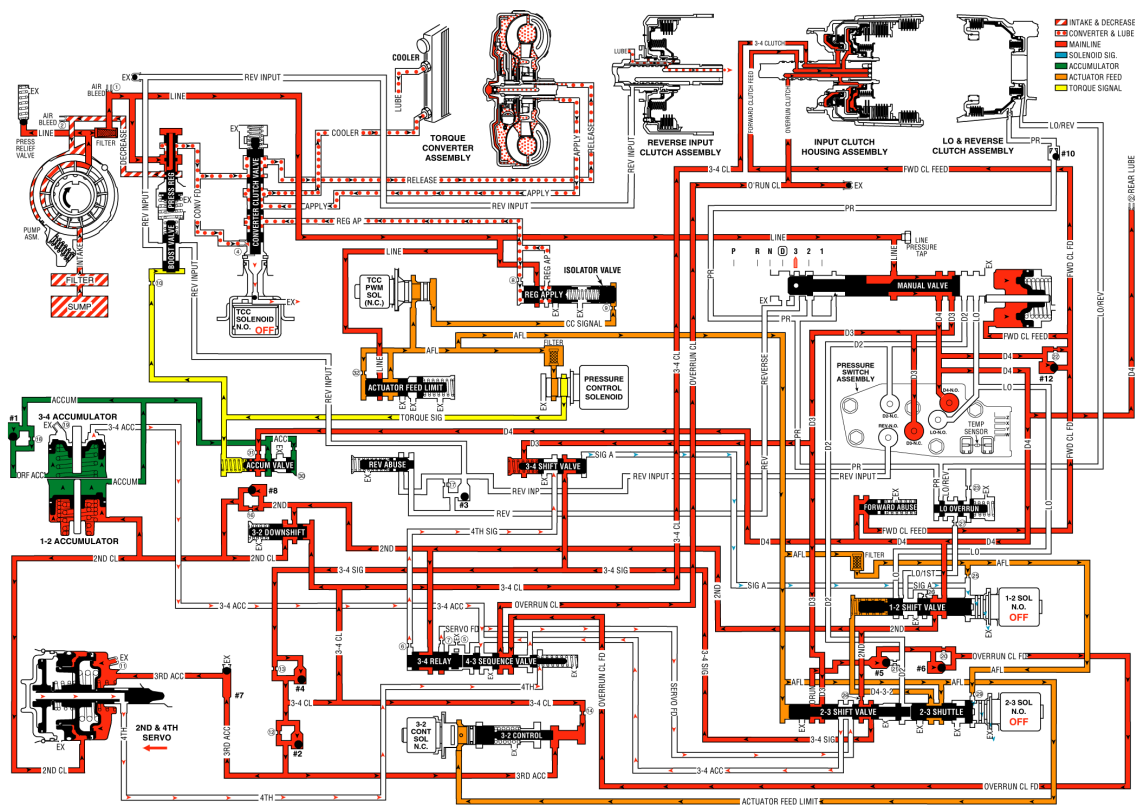

Fig. 495: Manual Third Gear Hydraulic Circuit Diagram
Courtesy of GENERAL MOTORS CORP.

MANUAL SECOND GEAR

A manual 3-2 downshift can be accomplished by moving the gear selector lever into the Manual Second (2) position when the transmission is operating in third gear. This causes the transmission to shift immediately into second gear regardless of vehicle operating conditions. Also, the transmission is prevented from operating in any other gear, first, third or fourth. The following information explains the additional changes during a manual 3-2 downshift, as compared to a forced 3-2 downshift. Some vehicles in manual second gear will start out in first gear, while other vehicles will have a second gear start. Refer to the owners manual for specific applications.

Manual Valve

The selector lever moves the manual shaft and the manual valve into the manual second (2) position. This allows the line pressure to enter the D2 fluid circuit.

Transmission Fluid Pressure (TFP) Manual Valve Position Switch Assembly

The D2 fluid is routed to the TFP manual valve position switch where it opens the normally closed D2 fluid pressure switch. With the D2 and the D3 pressure switches closed and the D4

2007 Hummer H3

2007 TRANSMISSION Automatic Transmission - 4L60-E/4L65-E/4L70-E - H3

pressure switch open, the TFP manual valve position switch signals the PCM that the transmission is operating in manual second.

Third and Fourth Gears Prevented

2-3 Shift Solenoid (SS) Valve

The PCM energizes the 2-3 SS valve and the AFL fluid pressure holds the 2-3 shift valve in the downshift position. This electronically prevents operation of the third and fourth gears.

2-3 Shift Valve Train

The D2 fluid is routed between the 2-3 shuttle and the 2-3 shift valves and causes the following:

- Regardless of the operating conditions, the D2 fluid pressure holds the 2-3 shift valve in the downshift position against the AFL fluid pressure.
- The 2nd fluid is blocked from entering the 3-4 signal fluid circuit and the 3-4 signal fluid circuit is open to an exhaust port at the valve.
- The 3-4 clutch cannot apply with the 3-4 signal fluid exhausted. Therefore, third and fourth gears are hydraulically prevented.
- The 2nd fluid feeds the servo feed fluid circuit, but the 2nd fluid circuit has no function in manual second.
- The AFL fluid is blocked by the 2-3 shift valve and the D432 fluid circuit is exhausted through the valve.
- The overrun fluid is exhausted through the 2-3 shuttle valve.

1-2 Shift Valve

The 1-2 SS valve is OFF, the signal A fluid exhausts through the solenoid and the spring force holds the valve in the upshifted position.

First Gear Prevented

The prevention of first gear is controlled electronically by the PCM through the 1-2 SS valve. The PCM keeps the 1-2 SS valve de-energized, regardless of the vehicle operating conditions when the TFP manual valve position switch signals manual second gear range. This keeps signal A fluid exhausted and the spring force holds the 1-2 shift valve in the upshift position.

Overrun Clutch Remains Applied

Overrun Clutch Feed Checkball (#5)

2007 Hummer H3

2007 TRANSMISSION Automatic Transmission - 4L60-E/4L65-E/4L70-E - H3

Orificed D2 fluid pressure seats the #5 checkball against the empty overrun clutch fluid circuit. This is done simultaneously with the overrun clutch fluid exhausting so that there is a continuous fluid supply to the overrun clutch feed fluid circuit.

Overrun Clutch Piston

A continuous supply of fluid pressure is routed to the piston in order to keep the overrun clutch plates applied.

Torque Converter Clutch

The converter clutch is released prior to downshifting into manual second-second gear. Under normal operating conditions, the TCC will not apply in second gear.

Pressure Control (PC) Solenoid Valve

IMPORTANT: Some vehicles in Manual Second Gear, at a stop, will start out in 1st gear, while others will have a second gear start. Refer to Vehicle Owners Manual.

The PCM output signal to the PC solenoid valve increases the operating range of torque signal fluid pressure in manual second. This provides the increased line pressure for the additional torque requirements during the engine compression braking and increased engine loads.

2007 Hummer H3

2007 TRANSMISSION Automatic Transmission - 4L60-E/4L65-E/4L70-E - H3

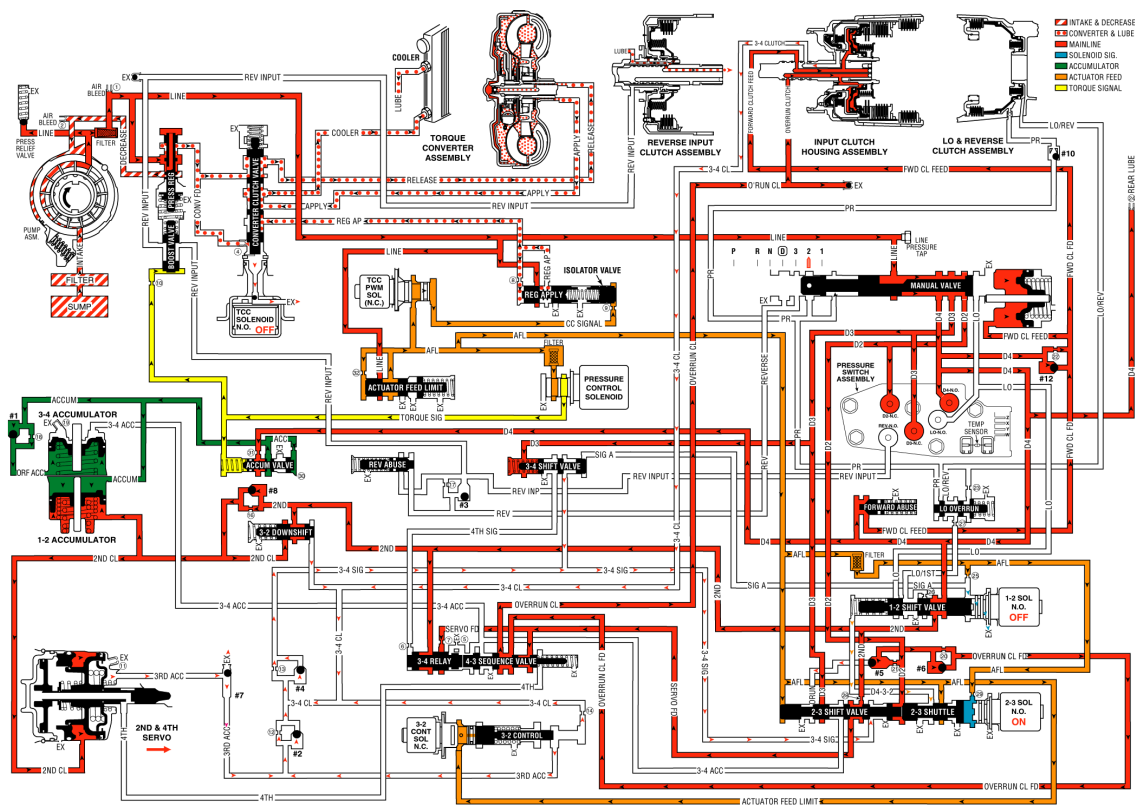

Fig. 496: Manual Second Gear Hydraulic Circuit Diagram
Courtesy of GENERAL MOTORS CORP.

MANUAL FIRST GEAR

A manual 2-1 downshift can be accomplished by moving the gear selector lever into the manual first (1) position when the transmission is operating in second gear. The downshift to first gear is controlled electronically by the PCM. The PCM will not energize the 1-2 shift solenoid valve to initiate the downshift until the vehicle speed is below approximately 48 to 56 km/h (30 to 35 mph). Above this speed, the transmission operates in a manual first-second gear state. The following text explains the manual 2-1 downshift.

Manual Valve

The selector lever moves the manual shaft and the manual valve into the manual first (1) position. This allows the line pressure to enter the Lo fluid circuit.

Transmission Fluid Pressure (TFP) Manual Valve Position Switch Assembly

Lo fluid is routed to the TFP manual valve position switch where it closes the normally open lo pressure switch. The addition of the lo pressure switch being closed signals to the PCM that manual first is selected.

2007 Hummer H3

2007 TRANSMISSION Automatic Transmission - 4L60-E/4L65-E/4L70-E - H3

2-3 Shift Solenoid (SS) Valve

In both first and second gears, this solenoid is energized and maintains the signal B fluid pressure at the solenoid end of the 2-3 shift valve train.

2-3 Shift Valve Train

Held in the downshift position by the signal B fluid pressure from the solenoid, the valve train blocks the AFL fluid from entering the D432 fluid circuit. The D432 fluid circuit is open to exhaust past the valve.

1-2 Shift Solenoid (SS) Valve

Below approximately 48 to 56 km/h (30 to 35 mph) the PCM energizes the normally open solenoid. This blocks the signal A fluid pressure from exhausting through the solenoid and creates the pressure in the signal A fluid circuit. Above this speed, the PCM keeps the solenoid de-energized and the transmission operates in manual first-second gear.

1-2 Shift Valve

Signal A fluid pressure moves the valve against the spring force and into the downshift position. In this position, Lo fluid from the manual valve is routed into the Lo/1st fluid circuit and D4 fluid is blocked from entering the 2nd fluid circuit. The 2nd fluid exhausts through an orifice and an annulus exhaust port past the valve. This orifice (#26) helps control the 2-4 band release during a 2-1 downshift.

2-4 Band Releases

2-4 Servo Assembly

The 2nd clutch fluid, which was fed by the 2nd fluid, exhausts from the servo. This allows the spring force from the servo cushion and the servo return springs to move the 2nd apply piston and apply the pin to release the 2-4 band. These spring forces help control the 2-4 band release.

1-2 Accumulator Assembly

The 2nd clutch fluid also exhausts from the 1-2 accumulator assembly. The spring force and the accumulator fluid pressure move the accumulator piston to assist the 2nd clutch fluid exhaust.

Accumulator Valve

As the accumulator fluid is filling the 1-2 accumulator assembly, the accumulator valve regulates the D4 fluid into the accumulator fluid circuit. This regulation, biased by torque signal fluid pressure and spring force, helps control the movement of the 1-2 accumulator piston. The 2nd

2007 Hummer H3

2007 TRANSMISSION Automatic Transmission - 4L60-E/4L65-E/4L70-E - H3

clutch fluid exhaust and the 2-4 band release.

1-2 Upshift Checkball (#8)

Exhausting the 2nd clutch fluid pressure unseats the ball and is routed through the 2nd fluid circuit.

Lo and Reverse Clutch Applies

Lo Overrun Valve

The Lo/1st fluid is regulated through the lo overrun valve and into the Lo/reverse fluid circuit in order to control the lo and reverse clutch apply.

Lo and Reverse Piston

The Lo/reverse fluid pressure acts on the inner area of the piston in order to move the piston and in order to apply the lo and reverse clutch plates.

Overrun Clutch Applied

The overrun clutch remains applied in manual first in order to provide engine compression braking.

Pressure Control (PC) Solenoid Valve

Similar to manual second, the PCM output signal to the PC solenoid valve increases the operating range of the torque signal fluid pressure. This provides the increased line pressure for the additional torque requirements during the engine compression braking and the increased engine loads.

3-2 Downshift Control Solenoid Valve and the 3-2 Control Valve

In first gear the solenoid is OFF, the AFL fluid is blocked by the solenoid and the 3-2 signal fluid exhausts through the solenoid and the spring force opens the 3-2 control valve.

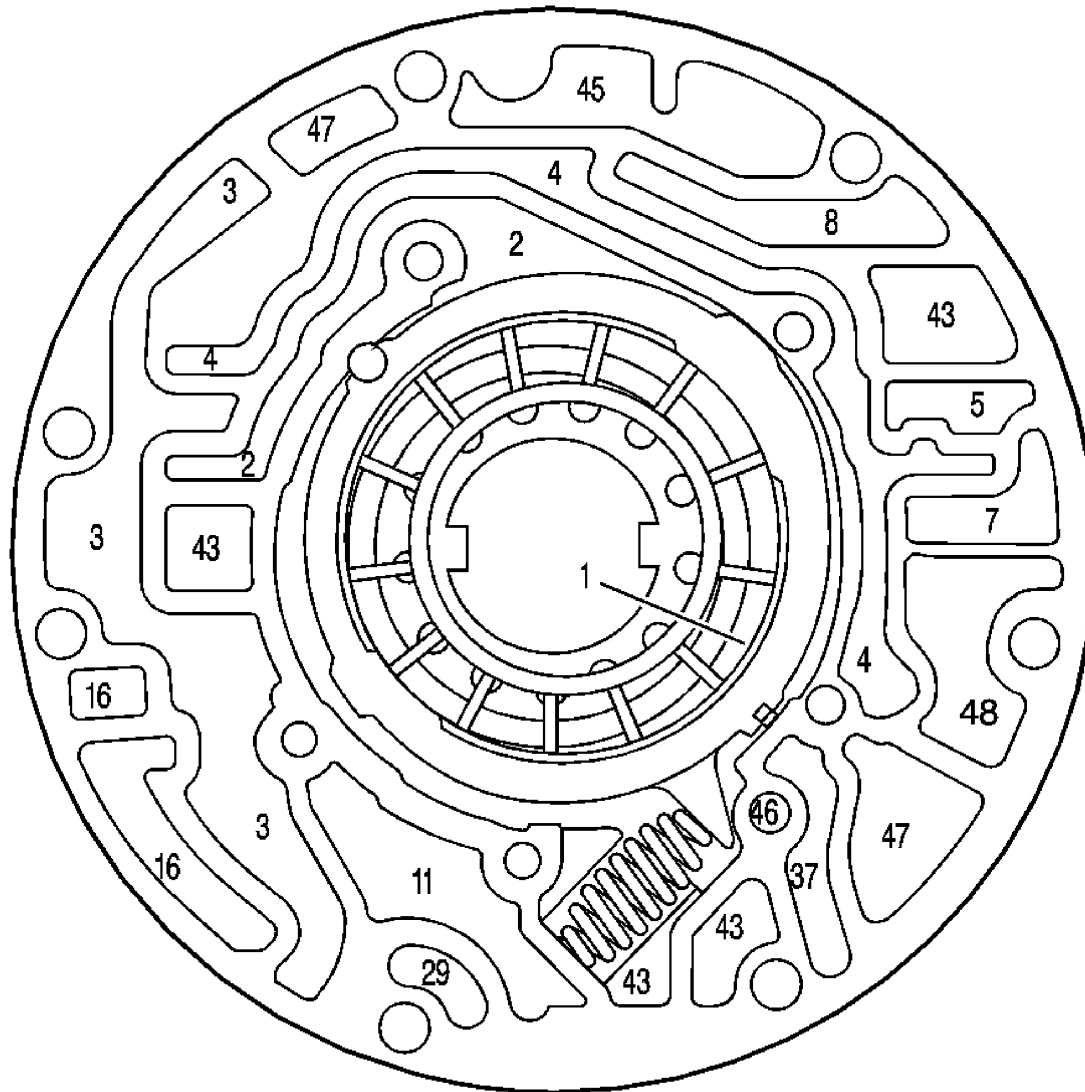

Fig. 498: Pump Body Fluid Passages (Pump Cover Side)
 Courtesy of GENERAL MOTORS CORP.

Callouts For Fig. 498

Callout	Component Name
1	Suction (intake)
2	Decrease
2	Decrease
3	Line
3	Line
3	Line

2007 Hummer H3

2007 TRANSMISSION Automatic Transmission - 4L60-E/4L65-E/4L70-E - H3

4	Converter Feed
4	Converter Feed
4	Converter Feed
5	Release
7	To Cooler
8	Lube from Cooler
11	Torque Signal
16	Reverse Input
16	Reverse Input
29	3-4 Clutch
37	Overrun Clutch
43	Exhaust
43	Exhaust
43	Exhaust
43	Exhaust
45	Vent
46	Seal Drain
47	Void
47	Void
48	Regulated Apply

2007 Hummer H3

2007 TRANSMISSION Automatic Transmission - 4L60-E/4L65-E/4L70-E - H3

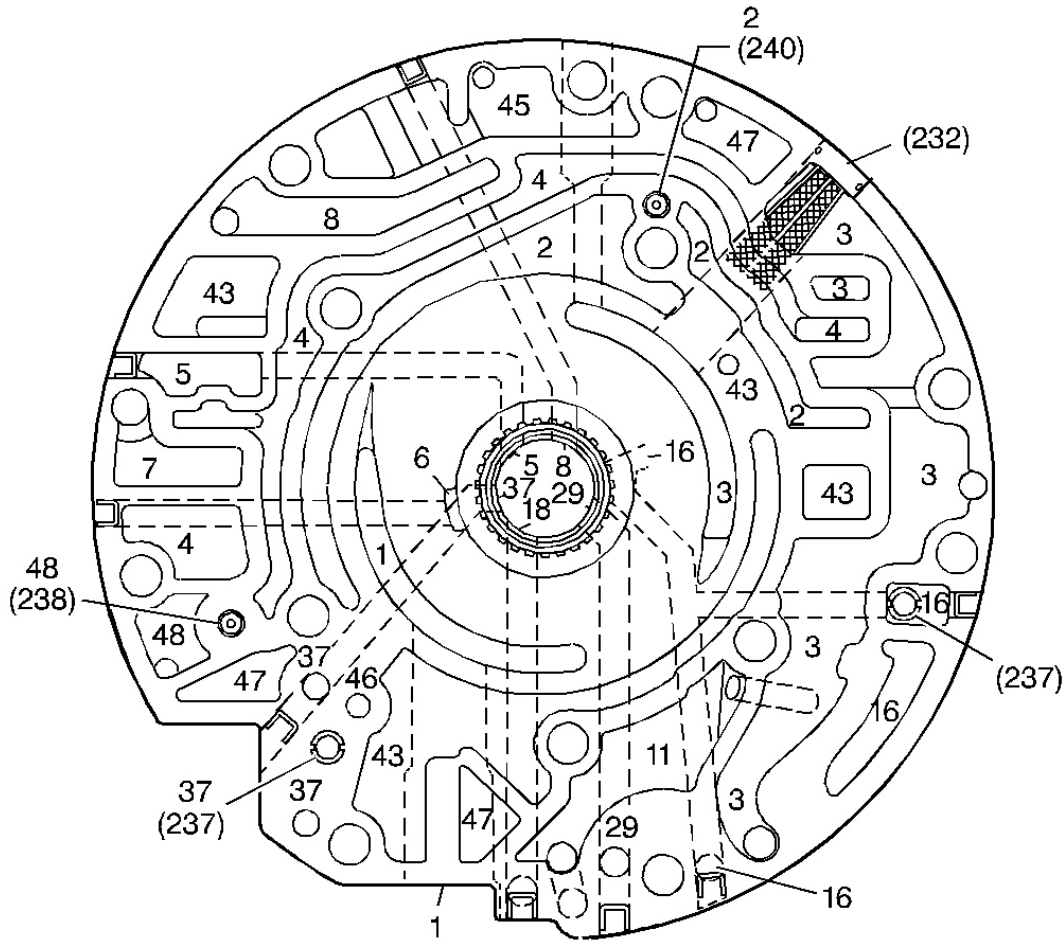

Fig. 499: Identifying Pump Cover Fluid Passages (Pump Body Side)
 Courtesy of GENERAL MOTORS CORP.

Callouts For Fig. 499

Callout	Component Name
1	Suction (intake)
1	Suction (intake)
2	Decrease
2	Decrease
2	Decrease
2	Decrease
3	Line
3	Line

2007 Hummer H3

2007 TRANSMISSION Automatic Transmission - 4L60-E/4L65-E/4L70-E - H3

3	Line
3	Line
3	Line
3	Line
4	Converter Feed
4	Converter Feed
4	Converter Feed
4	Converter Feed
5	Release
5	Release
6	Apply
7	To Cooler
8	Lube from Cooler
8	Lube from Cooler
11	Torque Signal
16	Reverse Input
16	Reverse Input
16	Reverse Input
16	Reverse Input
18	Forward Clutch Feed
29	3-4 Clutch
29	3-4 Clutch
37	Overrun Clutch
37	Overrun Clutch
37	Overrun Clutch
37	Overrun Clutch
43	Exhaust
43	Exhaust
43	Exhaust
43	Exhaust
45	Vent
46	Seal Drain
47	Void
47	Void
47	Void

2007 Hummer H3

2007 TRANSMISSION Automatic Transmission - 4L60-E/4L65-E/4L70-E - H3

	Regulated Apply
48	Regulated Apply
232	Oil Pump Cover Screen
237	Check Valve Retainer and Ball Assembly
237	Check Valve Retainer and Ball Assembly
238	Converter Clutch Signal Orificed Cup Plug
240	Orificed Cup Plug

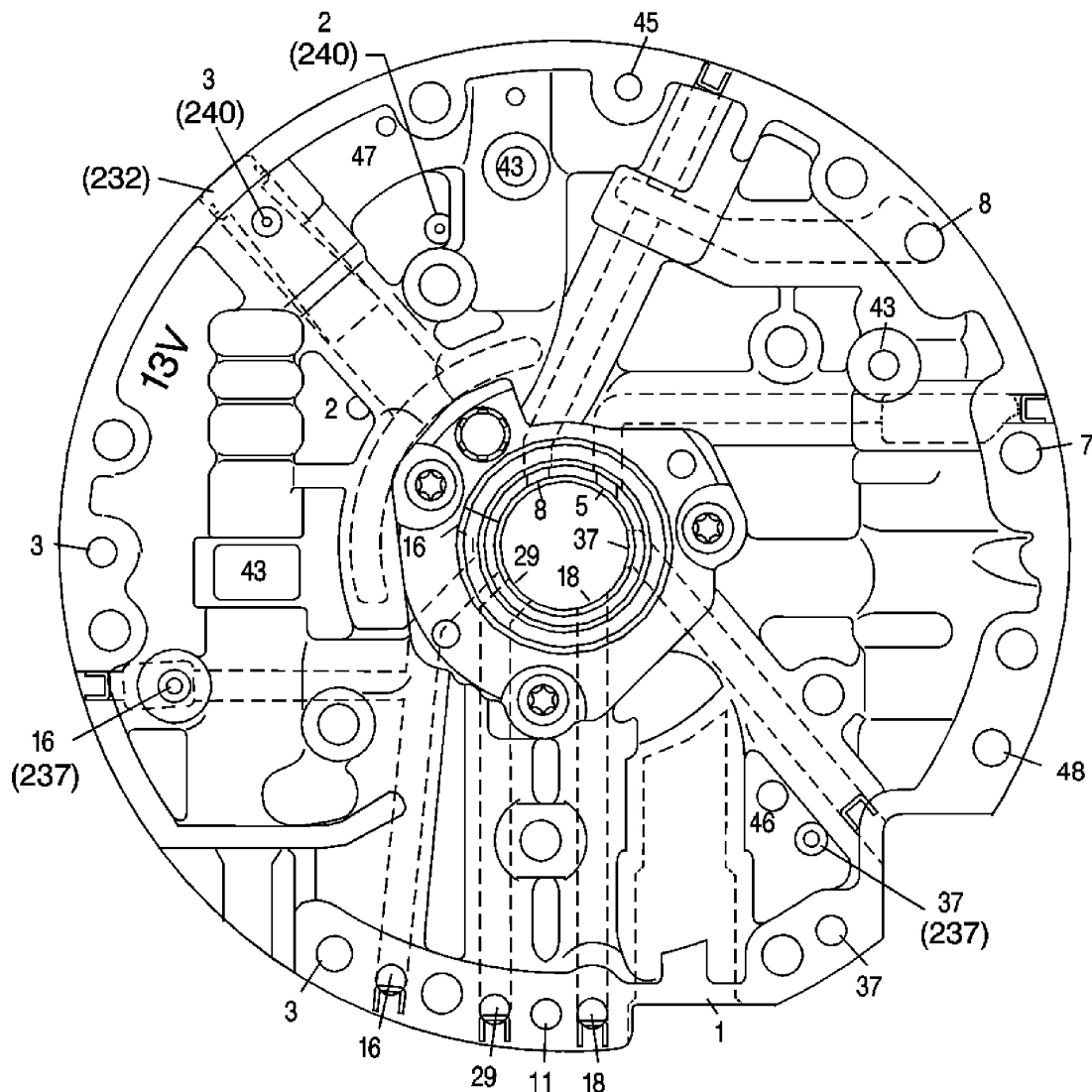

Fig. 500: View Of Pump Cover Fluid Passages (Case Side)
 Courtesy of GENERAL MOTORS CORP.

2007 Hummer H3

2007 TRANSMISSION Automatic Transmission - 4L60-E/4L65-E/4L70-E - H3

Callouts For Fig. 500

Callout	Component Name
1	Suction (Intake)
2	Decrease
2	Decrease
3	Line
3	Line
3	Line
5	Release
7	To Cooler
8	Lube from Cooler
8	Lube from Cooler
11	Torque Signal
16	Reverse Input (Rev. Clutch
16	Reverse Input (Rev. Clutch
16	Reverse Input (Rev. Clutch
18	Forward Clutch Feed
18	Forward Clutch Feed
29	3-4 Clutch
29	3-4 Clutch
37	Overrun Clutch
37	Overrun Clutch
37	Overrun Clutch
43	Exhaust
43	Exhaust
43	Exhaust
45	Vent
46	Seal Drain
47	Void
48	Regulated Apply
232	Oil Pump Cover Screen
237	Check Valve Retainer and Ball Assembly
237	Check Valve Retainer and Ball Assembly
240	Orificed Cup Plug
240	Orificed Cup Plug

2007 Hummer H3

2007 TRANSMISSION Automatic Transmission - 4L60-E/4L65-E/4L70-E - H3

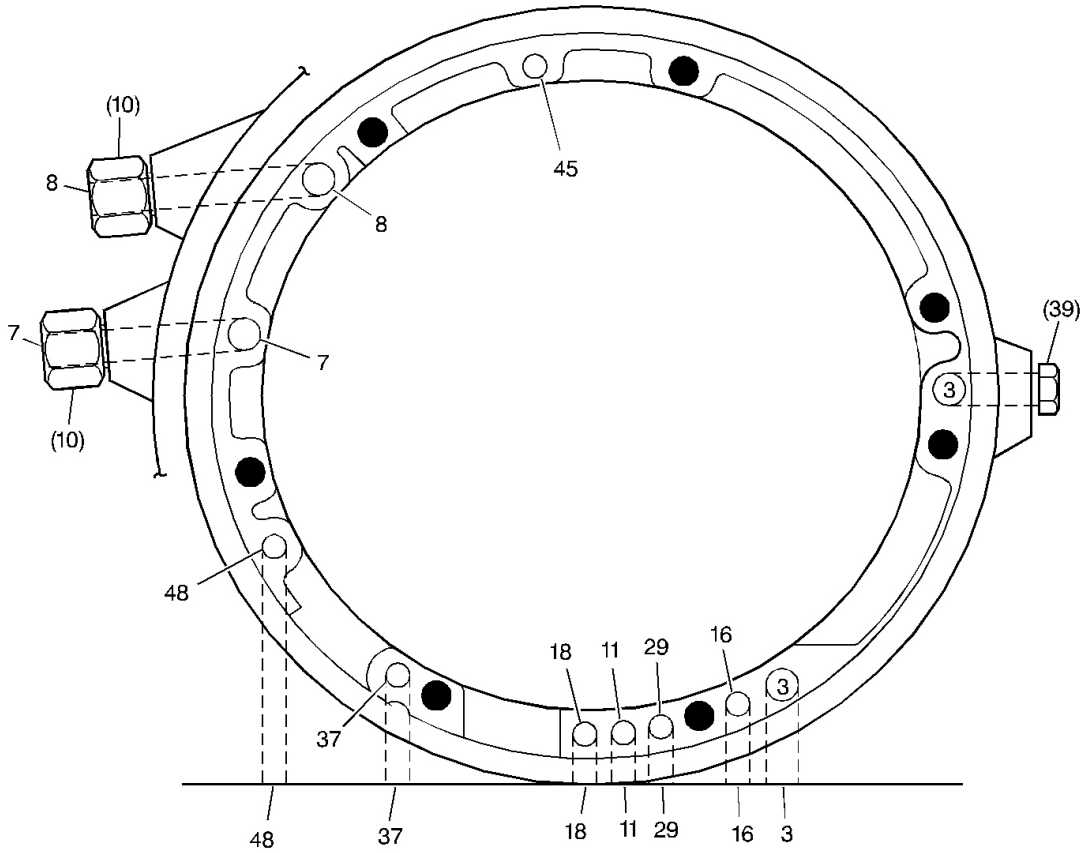

Fig. 501: Identifying Case Fluid Passages (Pump Cover Side)
 Courtesy of GENERAL MOTORS CORP.

Callouts For Fig. 501

Callout	Component Name
3	Line
3	Line
3	Line
7	To Cooler
7	To Cooler
8	Lube from Cooler
8	Lube from Cooler
10	Oil Cooler Pipe Connector
10	Oil Cooler Pipe Connector
11	Torque Signal

2007 Hummer H3

2007 TRANSMISSION Automatic Transmission - 4L60-E/4L65-E/4L70-E - H3

11	Torque Signal
16	Reverse Input
16	Reverse Input
18	Forward Clutch Feed
18	Forward Clutch Feed
29	3-4 Clutch
29	3-4 Clutch
37	Overrun Clutch
37	Overrun Clutch
39	Pressure Plug
45	Vent
48	Regulated Apply
48	Regulated Apply

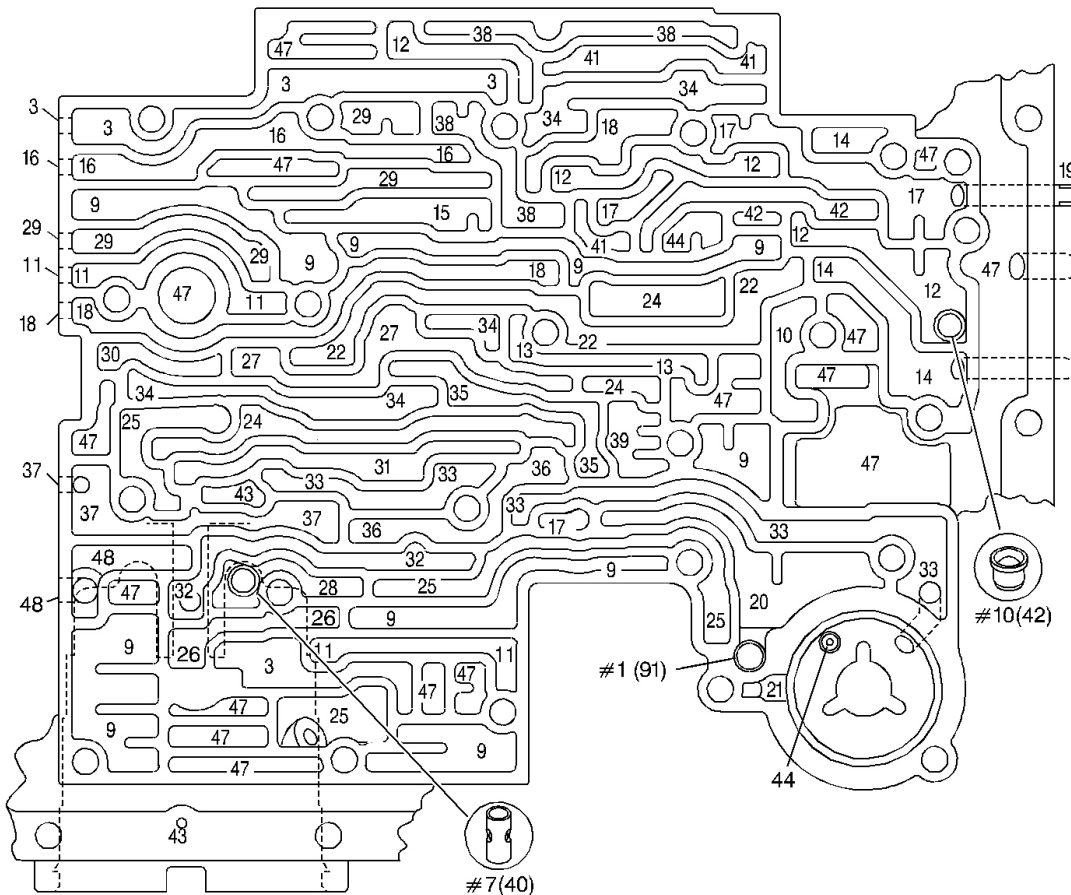

2007 Hummer H3

2007 TRANSMISSION Automatic Transmission - 4L60-E/4L65-E/4L70-E - H3

Fig. 502: Identifying Case Fluid Passages (Control Valve Body Side)
Courtesy of GENERAL MOTORS CORP.**Callouts For Fig. 502**

Callout	Component Name
#1	Checkball (91)
#7	3rd Accumulator Retainer and Ball Assembly (40)
#10	Checkball (42)
3	Line
3	Line
3	Line
3	Line
3	Line
9	Actuator Feed Limit
9	Actuator Feed Limit
9	Actuator Feed Limit
9	Actuator Feed Limit
9	Actuator Feed Limit
9	Actuator Feed Limit
9	Actuator Feed Limit
9	Actuator Feed Limit
9	Actuator Feed Limit
9	Actuator Feed Limit
9	Actuator Feed Limit
9	Actuator Feed Limit
10	Filtered Actuator Feed
11	Torque Signal
11	Torque Signal
11	Torque Signal
11	Torque Signal
11	Torque Signal
12	PR
12	PR
12	PR
12	PR
12	PR

2007 Hummer H3

2007 TRANSMISSION Automatic Transmission - 4L60-E/4L65-E/4L70-E - H3

13	D4-3-2
13	D4-3-2
14	Lo/Reverse
14	Lo/Reverse
14	Lo/Reverse
15	Reverse
16	Reverse Input (Rev. Clutch
16	Reverse Input (Rev. Clutch
16	Reverse Input (Rev. Clutch
16	Reverse Input (Rev. Clutch
17	D4
17	D4
17	D4
17	D4
18	Forward Clutch Feed
18	Forward Clutch Feed
18	Forward Clutch Feed
18	Forward Clutch Feed
19	Rear Lube
20	Accumulator
21	Orificed Accumulator
22	Signal A
22	Signal A
22	Signal A
24	2nd
24	2nd
24	2nd
25	2nd Clutch
25	2nd Clutch
25	2nd Clutch
25	2nd Clutch
26	C.C. Signal
26	C.C. Signal
27	3-4 Signal
27	3-4 Signal

2007 Hummer H3

2007 TRANSMISSION Automatic Transmission - 4L60-E/4L65-E/4L70-E - H3

	3rd Accumulator
29	3-4 Clutch
29	3-4 Clutch
29	3-4 Clutch
29	3-4 Clutch
29	3-4 Clutch
30	4th Signal
31	Servo Feed
32	4th
32	4th
33	3-4 Accumulator
33	3-4 Accumulator
33	3-4 Accumulator
33	3-4 Accumulator
33	3-4 Accumulator
34	D3
34	D3
34	D3
34	D3
34	D3
35	Overrun
35	Overrun
36	Overrun Clutch Feed
36	Overrun Clutch Feed
37	Overrun Clutch
37	Overrun Clutch
37	Overrun Clutch
38	D2
38	D2
38	D2
38	D2
39	Orificed D2
41	Lo
41	Lo
41	Lo

2007 Hummer H3

2007 TRANSMISSION Automatic Transmission - 4L60-E/4L65-E/4L70-E - H3

9	Actuator Feed Limit
9	Actuator Feed Limit
9	Actuator Feed Limit
9	Actuator Feed Limit
10	Filtered Actuator Feed
10	Filtered Actuator Feed
10	Filtered Actuator Feed
10	Filtered Actuator Feed
10	Filtered Actuator Feed
11	Torque Signal
11	Torque Signal
11	Torque Signal
12	PR
12	PR
12	PR
12	PR
12	PR
13	D4-3-2
13	D4-3-2
14	Lo/Reverse
14	Lo/Reverse
14	Lo/Reverse
15	Reverse
15	Reverse
16	Reverse Input (Rev. Cl.)
16	Reverse Input (Rev. Cl.)
16	Reverse Input (Rev. Cl.)
17	D4
17	D4
17	D4
17	D4
18	Forward Clutch Feed
18	Forward Clutch Feed
18	Forward Clutch Feed
18	Forward Clutch Feed

2007 Hummer H3

2007 TRANSMISSION Automatic Transmission - 4L60-E/4L65-E/4L70-E - H3

	3-4 Clutch
29	3-4 Clutch
29	3-4 Clutch
29	3-4 Clutch
29	3-4 Clutch
29	3-4 Clutch
29	3-4 Clutch
30	4th Signal
30	4th Signal
31	Servo Feed
31	Servo Feed
31	Servo Feed
32	4th
33	3-4 Accumulator
33	3-4 Accumulator
33	3-4 Accumulator
34	D3
34	D3
34	D3
34	D3
34	D3
34	D3
35	Overrun
35	Overrun
36	Overrun Clutch Feed
36	Overrun Clutch Feed
37	Overrun Clutch
38	D2
38	D2
38	D2
38	D2
39	Orificed D2
39	Orificed D2
41	Lo
41	Lo

2007 Hummer H3

2007 TRANSMISSION Automatic Transmission - 4L60-E/4L65-E/4L70-E - H3

	Lo
41	Lo
42	Lo/1st
42	Lo/1st
43	Exhaust
43	Exhaust
44	Orificed Exhaust
44	Orificed Exhaust
47	Void
47	Void
48	Regulated Apply
48	Regulated Apply

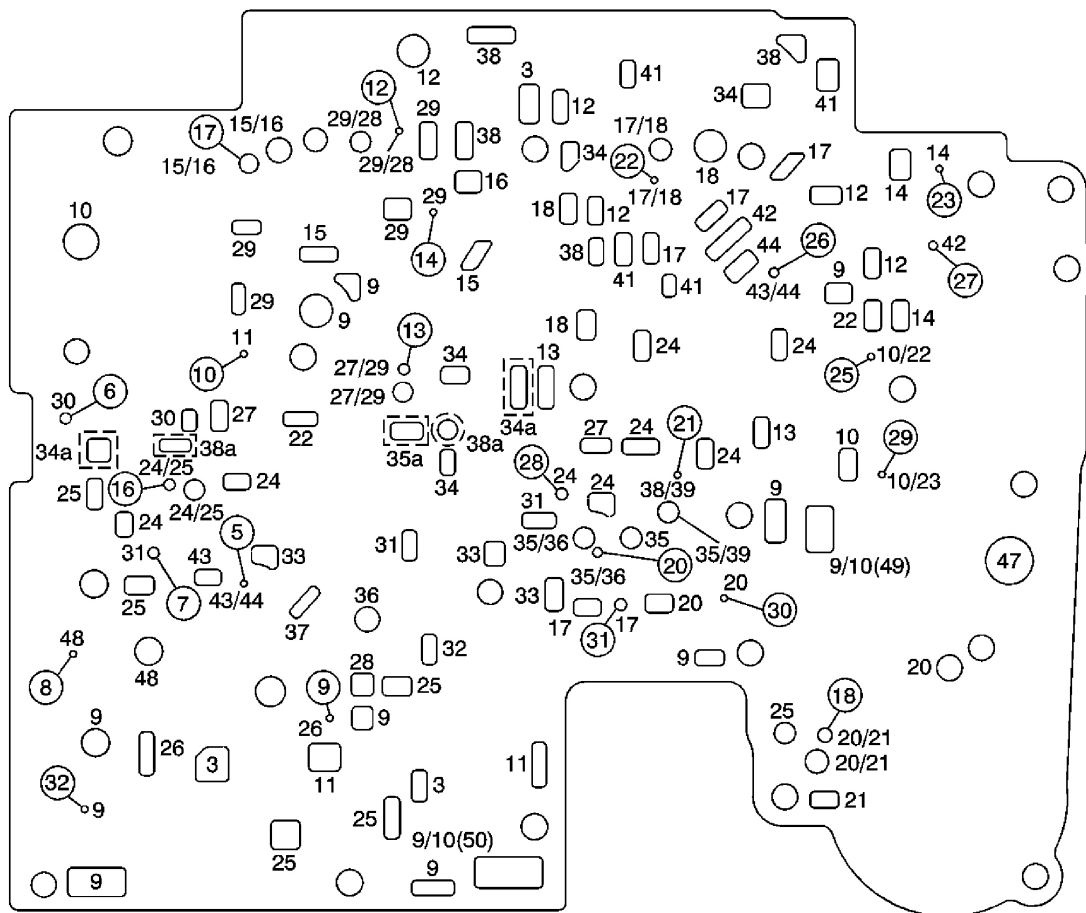

Fig. 504: Identifying Spacer Plate Fluid Passages
 Courtesy of GENERAL MOTORS CORP.

2007 Hummer H3

2007 TRANSMISSION Automatic Transmission - 4L60-E/4L65-E/4L70-E - H3

Callouts For Fig. 504

Callout	Component Name
3	Line
3	Line
3	Line
9	Actuator Feed Limit
9	Actuator Feed Limit
9	Actuator Feed Limit
9	Actuator Feed Limit
9	Actuator Feed Limit
9	Actuator Feed Limit
9	Actuator Feed Limit
9	Actuator Feed Limit
9	Actuator Feed Limit
9	Actuator Feed Limit
9	Actuator Feed Limit
9/10	Actuator Feed Limit/Filtered Actuator Feed
9/10	Actuator Feed Limit/Filtered Actuator Feed
10	Filtered Actuator Feed
10	Filtered Actuator Feed
10/22	Filtered Actuator Feed/Signal A
10/23	Filtered Actuator Feed/Signal B
11	Torque Signal
11	Torque Signal
11	Torque Signal
12	PR
12	PR
12	PR
12	PR
12	PR
13	D4-3-2
13	D4-3-2
14	Lo/Reverse
14	Lo/Reverse
14	Lo/Reverse
15	Reverse

2007 Hummer H3

2007 TRANSMISSION Automatic Transmission - 4L60-E/4L65-E/4L70-E - H3

15	Reverse
15/16	Reverse/Reverse Input (Rev. Clutch
15/16	Reverse/Reverse Input (Rev. Clutch
16	Reverse Input (Rev. Clutch
17	D4
17	D4
17	D4
17	D4
17	D4
17/18	D4
17/18	D4
18	Forward Clutch Feed
18	Forward Clutch Feed
18	Forward Clutch Feed
20	Accumulator
20	Accumulator
20	Accumulator
20/21	Accumulator/Orificed Accumulator
20/21	Accumulator/Orificed Accumulator
21	Orificed Accumulator
22	Signal A
22	Signal A
24	2nd
24	2nd
24	2nd
24	2nd
24	2nd
24	2nd
24	2nd
24	2nd
24	2nd
24/25	2nd/2nd Clutch
24/25	2nd/2nd Clutch
25	2nd Clutch
25	2nd Clutch
25	2nd Clutch

2007 Hummer H3

2007 TRANSMISSION Automatic Transmission - 4L60-E/4L65-E/4L70-E - H3

	2nd Clutch
25	2nd Clutch
25	2nd Clutch
26	C.C. Signal
26	C.C. Signal
27	3-4 Signal
27	3-4 Signal
27/29	3-4 Signal
27/29	3-4 Signal
28	3rd Accumulator
29/28	3-4 Clutch/3rd Accumulator
29/28	3-4 Clutch/3rd Accumulator
29	3-4 Clutch
29	3-4 Clutch
29	3-4 Clutch
29	3-4 Clutch
29	3-4 Clutch
30	4th Signal
30	4th Signal
31	Servo Feed
31	Servo Feed
31	Servo Feed
32	4th
33	3-4 Accumulator
33	3-4 Accumulator
33	3-4 Accumulator
34a	D3 - Blocked on M33 Models
34a	D3 - Blocked on M33 Models
34	D3
34	D3
34	D3
34	D3
34	D3
34	D3
34	D3
35a	Overrun- Blocked on M33 Models

2007 Hummer H3

2007 TRANSMISSION Automatic Transmission - 4L60-E/4L65-E/4L70-E - H3

	Overrun- Blocked on M33 Models
35	Overrun
35/36	Overrun/Overrun Clutch Feed
35/36	Overrun/Overrun Clutch Feed
35/39	Overrun/Orificed D2
36	Overrun Clutch Feed
37	Overrun Clutch
38a	D2 - M33 Models Only
38a	D2 - M33 Models Only
38	D2
38	D2
38	D2
38	D2
38	D2
38	D2
38	D2
38/39	D2/Orificed D2
41	Lo
41	Lo
41	Lo
41	Lo
42	Lo/1st
42	Lo/1st
43	Exhaust
43/44	Exhaust/Orificed Exhaust
43/44	Exhaust/Orificed Exhaust
44	Orificed Exhaust
47	Void
48	Regulated Apply
48	Regulated Apply
49	Shift Solenoids Screen
50	Pressure Control Solenoid Screen

2007 Hummer H3

2007 TRANSMISSION Automatic Transmission - 4L60-E/4L65-E/4L70-E - H3

9	Actuator Feed Limit
9	Actuator Feed Limit
9	Actuator Feed Limit
10	Filtered Actuator Feed
10	Filtered Actuator Feed
10	Filtered Actuator Feed
10	Filtered Actuator Feed
11	Torque Signal
11	Torque Signal
11	Torque Signal
12	PR
12	PR
12	PR
12	PR
12	PR
13	D4-3-2
13	D4-3-2
14	Lo/Reverse
14	Lo/Reverse
14	Lo/Reverse
15	Reverse
15	Reverse
15	Reverse
16	Reverse Input (Rev. Cl.)
17	D4
17	D4
17	D4
17	D4
17	D4
17	D4
18	Forward Clutch Feed
18	Forward Clutch Feed
18	Forward Clutch Feed
20	Accumulator
20	Accumulator

2007 Hummer H3

2007 TRANSMISSION Automatic Transmission - 4L60-E/4L65-E/4L70-E - H3

	Accumulator
21	Orificed Accumulator
22	Signal A
22	Signal A
22	Signal A
23	Signal B
24	2nd
24	2nd
24	2nd
24	2nd
24	2nd
24	2nd
24	2nd
24	2nd
24	2nd
24	2nd
25	2nd Clutch
25	2nd Clutch
25	2nd Clutch
25	2nd Clutch
25	2nd Clutch
25	2nd Clutch
25	2nd Clutch
25	2nd Clutch
25	2nd Clutch
25	2nd Clutch
26	C.C. Signal
26	C.C. Signal
27	3-4 Signal
27	3-4 Signal
28	3rd Accumulator
28	3rd Accumulator
29	3-4 Clutch
29	3-4 Clutch
29	3-4 Clutch
29	3-4 Clutch
29	3-4 Clutch

2007 Hummer H3

2007 TRANSMISSION Automatic Transmission - 4L60-E/4L65-E/4L70-E - H3

	3-4 Clutch
30	4th Signal
30	4th Signal
31	Servo Feed
31	Servo Feed
31	Servo Feed
32	4th
33	3-4 Accumulator
33	3-4 Accumulator
33	3-4 Accumulator
34	D3
34	D3
34	D3
34	D3
34	D3
34	D3
34	D3
35	Overrun
35	Overrun
35/39	Overrun/Orificed D2
36	Overrun Clutch Feed
37	Overrun Clutch
38	D2
38	D2
38	D2
38	D2
38	D2
40	3-2 Signal
40	3-2 Signal
41	Lo
41	Lo
41	Lo
41	Lo
42	Lo/1st
42	Lo/1st
43	Exhaust

2007 Hummer H3

2007 TRANSMISSION Automatic Transmission - 4L60-E/4L65-E/4L70-E - H3

	Exhaust
44	Orificed Exhaust
44	Orificed Exhaust
47	Void
48	Regulated Apply
48	Regulated Apply

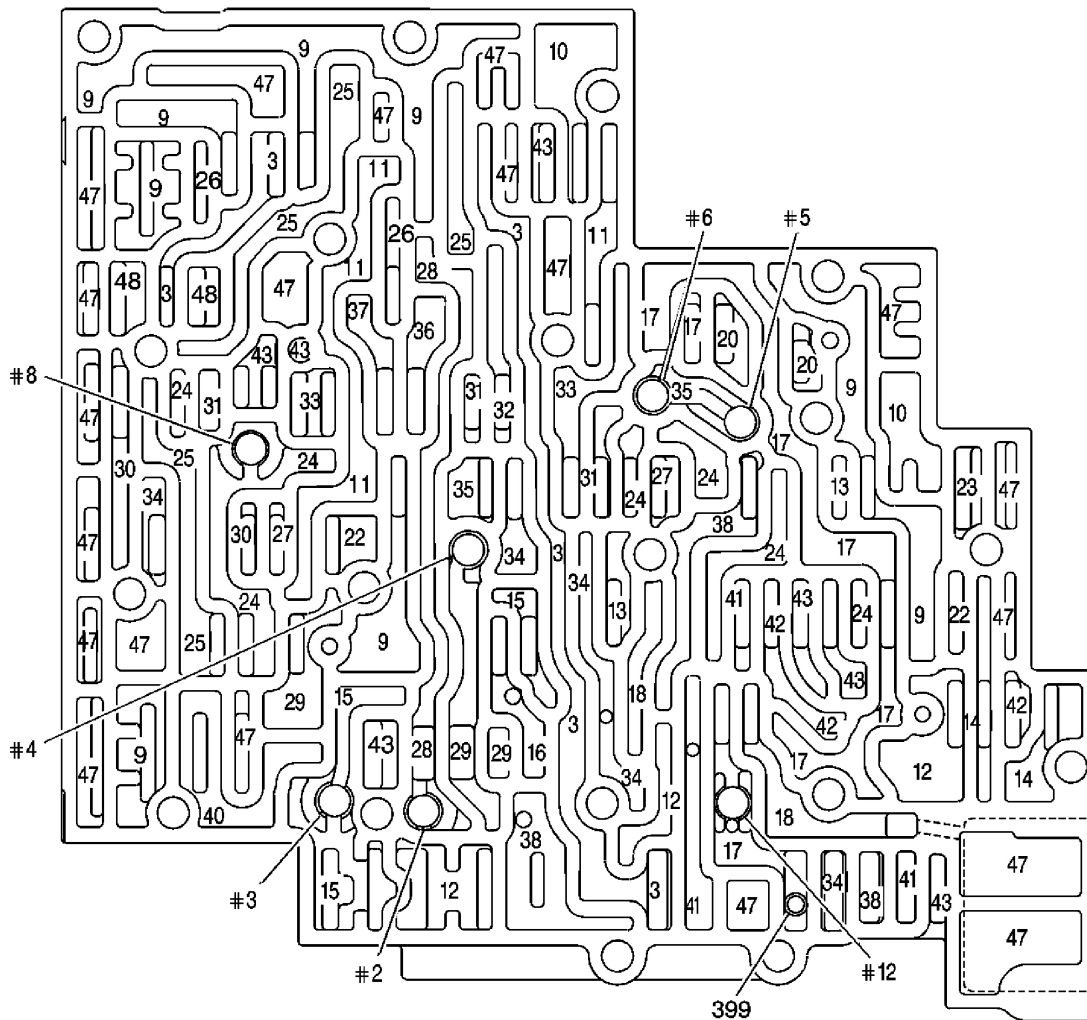

Fig. 506: Identifying Control Valve Body Fluid Passages (Case Side)
 Courtesy of GENERAL MOTORS CORP.

Callouts For Fig. 506

Callout	Component Name
#2	Checkball (61)

2007 Hummer H3

2007 TRANSMISSION Automatic Transmission - 4L60-E/4L65-E/4L70-E - H3

#3	Checkball (61)
#4	Checkball (61)
#5	Checkball (61)
#6	Checkball (61)
#8	Checkball (61)
#12	Checkball (61)
3	Line
3	Line
3	Line
3	Line
3	Line
3	Line
9	Actuator Feed Limit
9	Actuator Feed Limit
9	Actuator Feed Limit
9	Actuator Feed Limit
9	Actuator Feed Limit
9	Actuator Feed Limit
9	Actuator Feed Limit
9	Actuator Feed Limit
9	Actuator Feed Limit
9	Actuator Feed Limit
10	Filtered Actuator Feed
10	Filtered Actuator Feed
11	Torque Signal
11	Torque Signal
11	Torque Signal
11	Torque Signal
12	PR
12	PR
12	PR
13	D4-3-2
13	D4-3-2
14	Lo/Reverse
14	Lo/Reverse
15	Reverse

2007 Hummer H3

2007 TRANSMISSION Automatic Transmission - 4L60-E/4L65-E/4L70-E - H3

	Reverse
15	Reverse
16	Reverse Input (Rev. Clutch)
17	D4
17	D4
17	D4
17	D4
17	D4
17	D4
17	D4
17	D4
18	Forward Clutch Feed
18	Forward Clutch Feed
20	Accumulator
20	Accumulator
22	Signal A
22	Signal A
23	Signal B
24	2nd
24	2nd
24	2nd
24	2nd
24	2nd
24	2nd
24	2nd
24	2nd
25	2nd Clutch
25	2nd Clutch
25	2nd Clutch
25	2nd Clutch
25	2nd Clutch
25	2nd Clutch
26	C.C. Signal
26	C.C. Signal
27	3-4 Signal
27	3-4 Signal
28	3rd Accumulator

2007 Hummer H3

2007 TRANSMISSION Automatic Transmission - 4L60-E/4L65-E/4L70-E - H3

	3rd Accumulator
29	3-4 Clutch
29	3-4 Clutch
29	3-4 Clutch
30	4th Signal
30	4th Signal
31	Servo Feed
31	Servo Feed
31	Servo Feed
32	4th
33	3-4 Accumulator
33	3-4 Accumulator
34	D3
34	D3
34	D3
34	D3
34	D3
35	Overrun
35	Overrun
36	Overrun Clutch Feed
37	Overrun Clutch
38	D2
38	D2
38	D2
40	3-2 Signal
41	Lo
41	Lo
41	Lo
42	Lo/1st
42	Lo/1st
42	Lo/1st
43	Exhaust
43	Exhaust
43	Exhaust
43	Exhaust

2007 Hummer H3

2007 TRANSMISSION Automatic Transmission - 4L60-E/4L65-E/4L70-E - H3

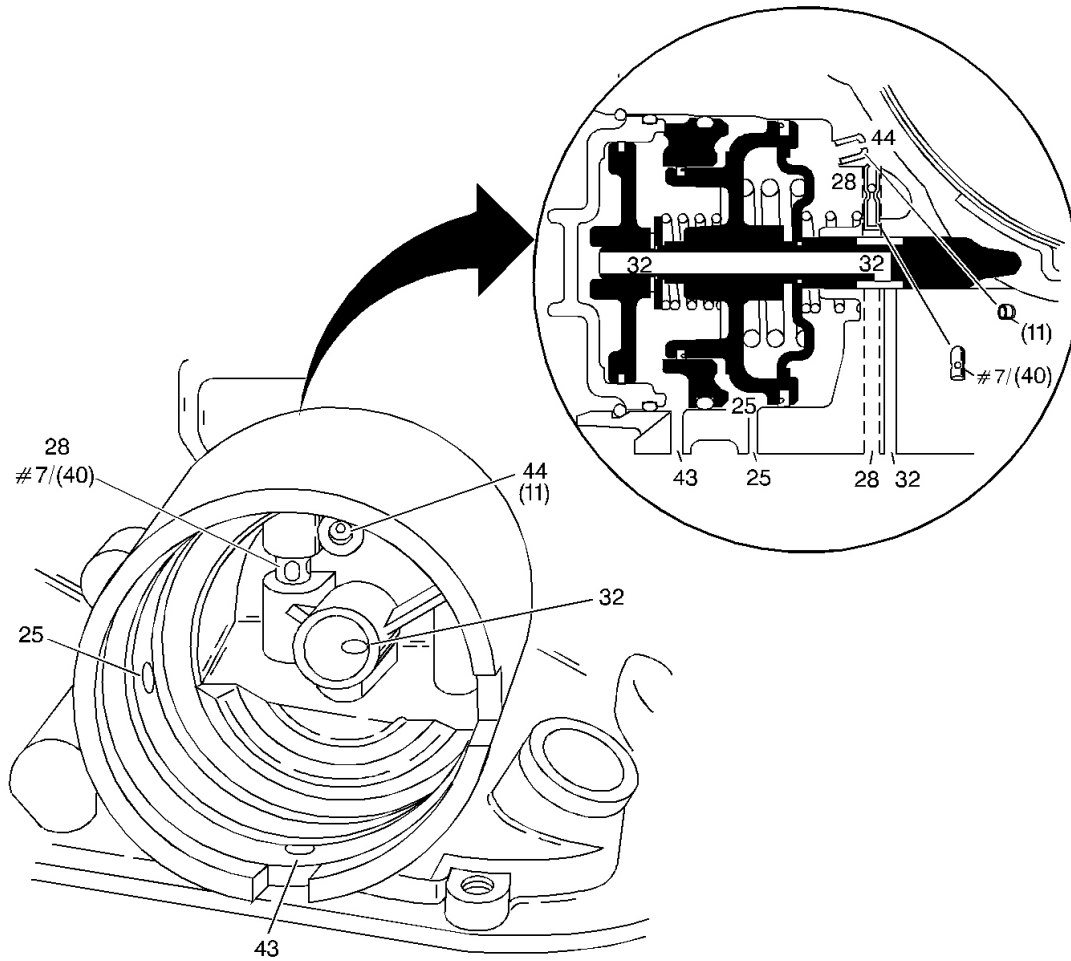

Fig. 507: Identifying 2-4 Servo Fluid Passages
 Courtesy of GENERAL MOTORS CORP.

Callouts For Fig. 507

Callout	Component Name
#7	3rd Accumulator Retainer and Ball Assembly (40)
#7	3rd Accumulator Retainer and Ball Assembly (40)
11	Case Servo Orificed Plug
11	Case Servo Orificed Plug
25	2nd Clutch
25	2nd Clutch
25	2nd Clutch
28	3rd Accumulator

2007 Hummer H3

2007 TRANSMISSION Automatic Transmission - 4L60-E/4L65-E/4L70-E - H3

28	3rd Accumulator
28	3rd Accumulator
32	4th
32	4th
32	4th
32	4th
43	Exhaust
43	Exhaust
44	Orificed Exhaust
44	Orificed Exhaust

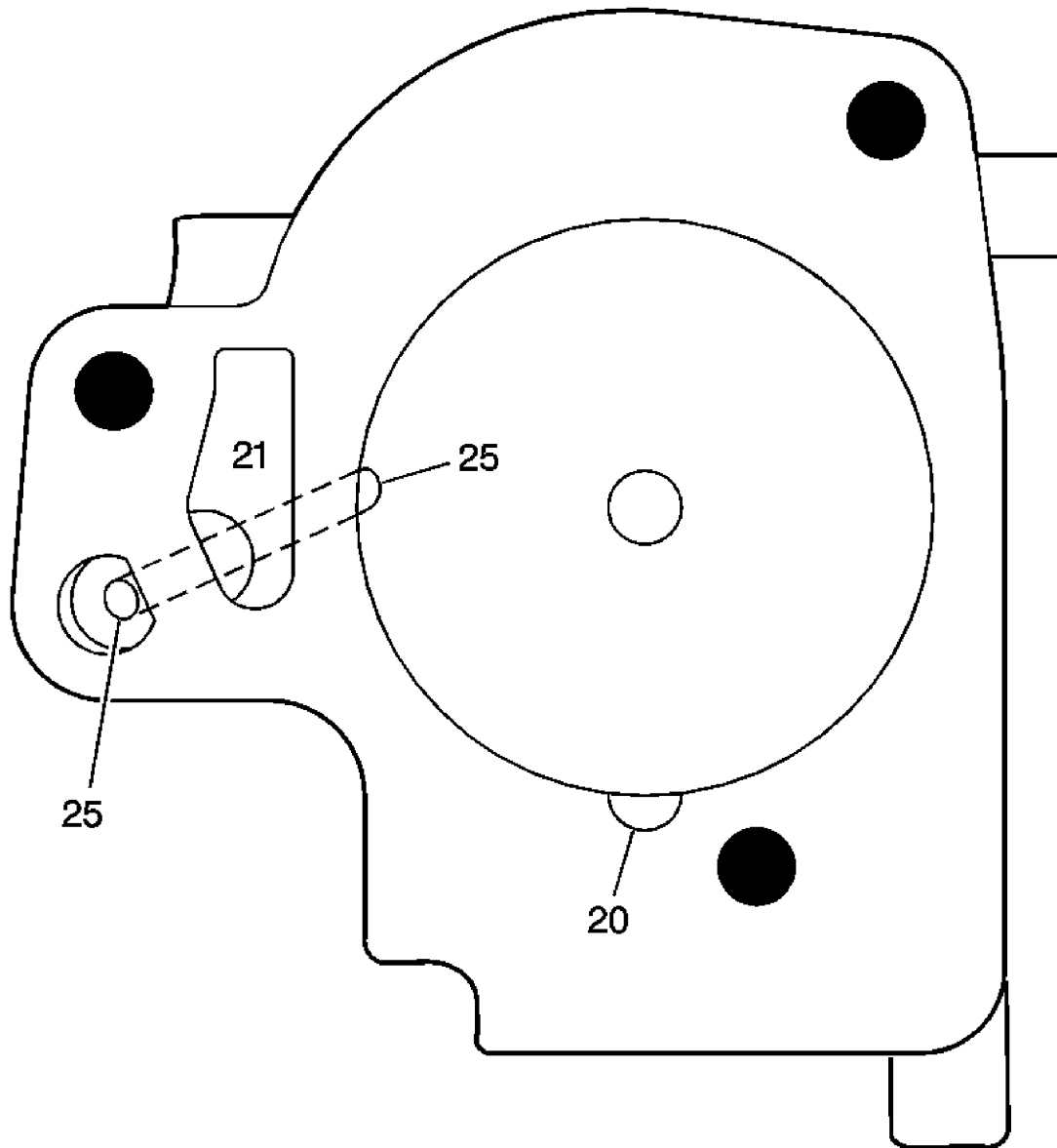

Fig. 508: Identifying 1-2 Accumulator Cover Fluid Passages
 Courtesy of GENERAL MOTORS CORP.

Callouts For Fig. 508

Callout	Component Name
20	Accumulator
21	Orificed Accumulator
25	2nd Clutch
25	2nd Clutch

SPECIAL TOOLS

Special Tools

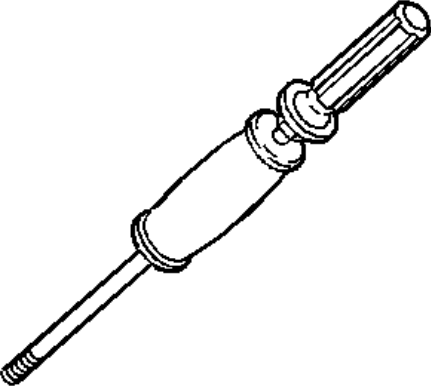
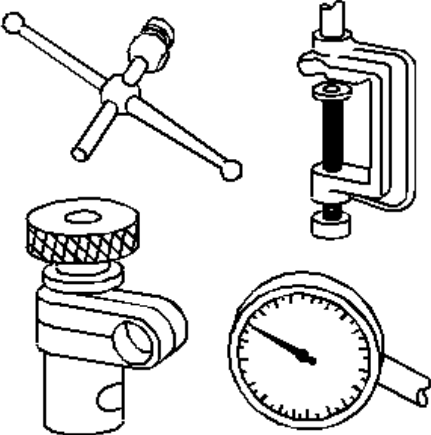
Illustration	Tool Number/Description
	<p>J 7004-A Universal Remover</p>
	<p>J 8001 Dial Indicator Set</p>

2007 Hummer H3

2007 TRANSMISSION Automatic Transmission - 4L60-E/4L65-E/4L70-E - H3

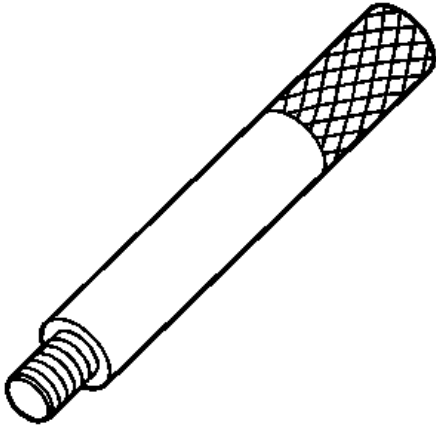

J 8092
Driver Handle

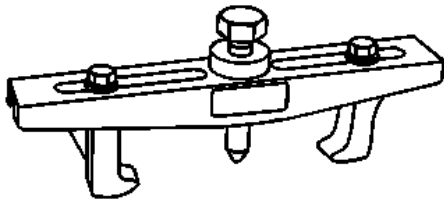

J 8433
Two Jaw Puller

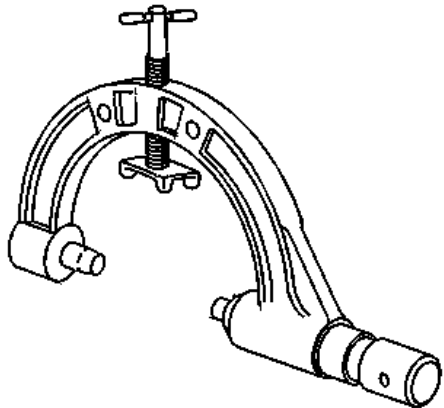

J 8763-02
Holding Fixture and Base

2007 Hummer H3

2007 TRANSMISSION Automatic Transmission - 4L60-E/4L65-E/4L70-E - H3

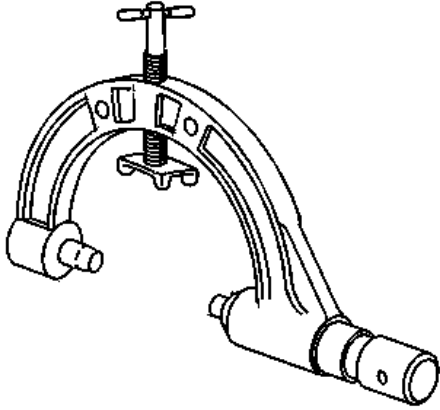

J 8763-B
Holding Fixture and Base

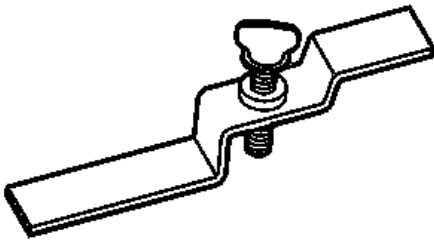

J 21366
Converter Holding Strap

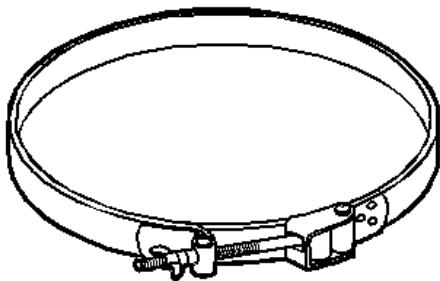

J 21368
Pump Body and Cover Alignment Band

2007 Hummer H3

2007 TRANSMISSION Automatic Transmission - 4L60-E/4L65-E/4L70-E - H3

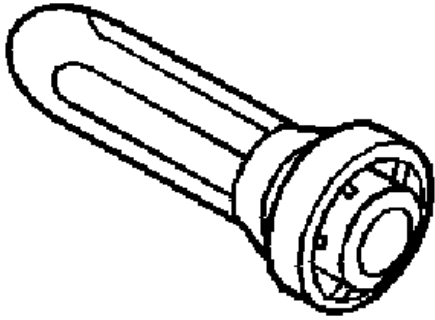

J 21426
Extension Housing Seal Installer

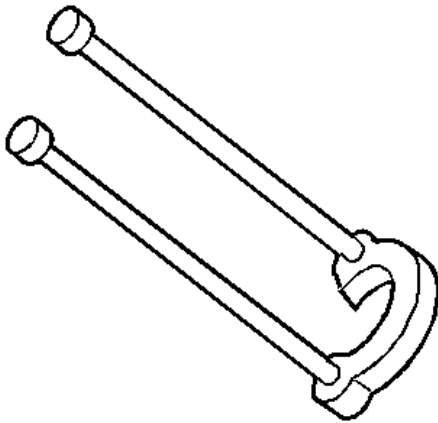

J 21427-01
Speedometer Gear Puller Adapter

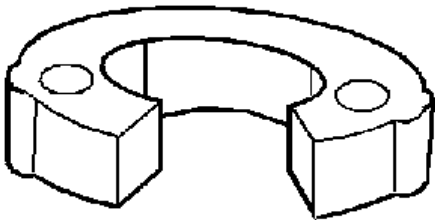

J 21427-A
Speedometer Gear Puller Adapter

2007 Hummer H3

2007 TRANSMISSION Automatic Transmission - 4L60-E/4L65-E/4L70-E - H3

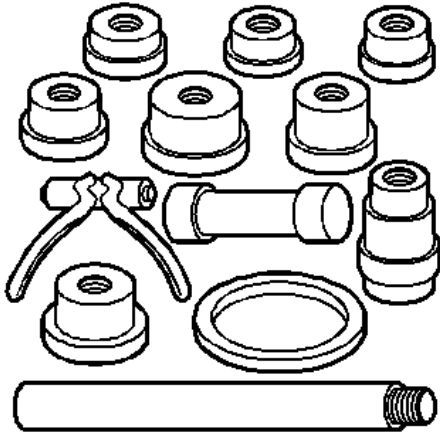

J 21465-01
Bushings Service Set

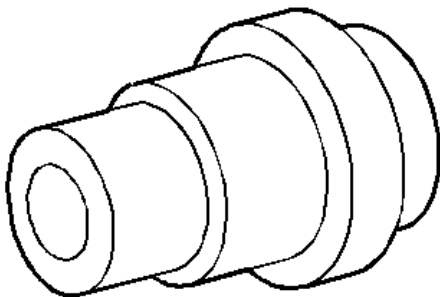

J 21465-2
Pump Cover Bushing Installer

J 21465-15
Sun Gear and Stator Shaft Bushing Remover

2007 Hummer H3

2007 TRANSMISSION Automatic Transmission - 4L60-E/4L65-E/4L70-E - H3

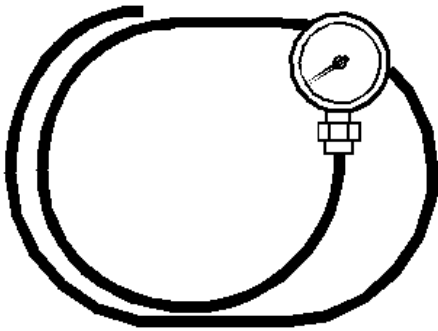
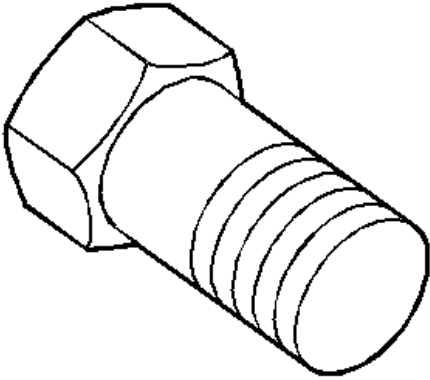

J 21867
Pressure Gage

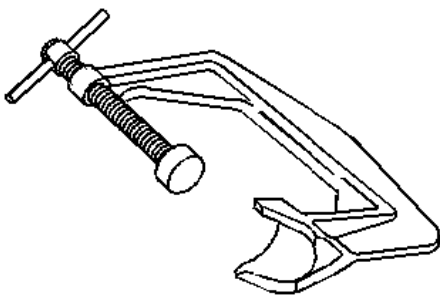

J 22269-01
Accumulator and Servo Piston Remover

2007 Hummer H3

2007 TRANSMISSION Automatic Transmission - 4L60-E/4L65-E/4L70-E - H3

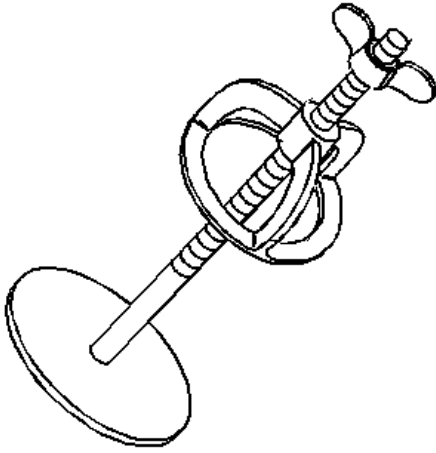

J 23327-1
Forward Clutch Spring Compressor (Bridge)

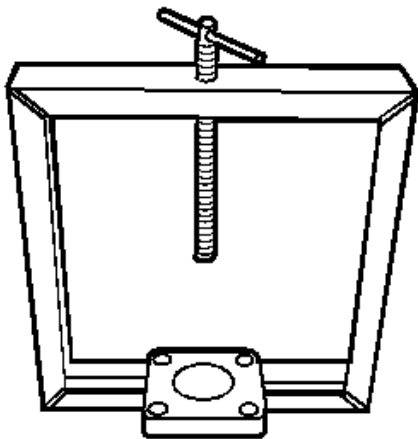

J 23456
Booster and Clutch Pack Compressor

J 23907
Slide Hammer with Bearing Adapter

2007 Hummer H3

2007 TRANSMISSION Automatic Transmission - 4L60-E/4L65-E/4L70-E - H3

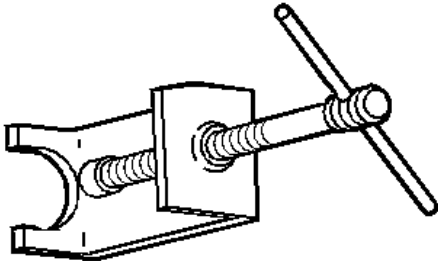
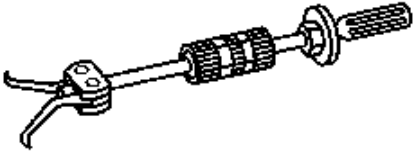

J 24773-A
Oil Pump Remover

J 25016
Pump Seal and Speedometer Gear Installer

2007 Hummer H3

2007 TRANSMISSION Automatic Transmission - 4L60-E/4L65-E/4L70-E - H3

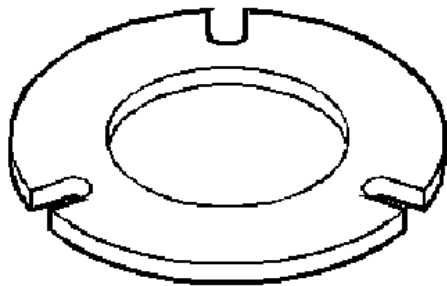
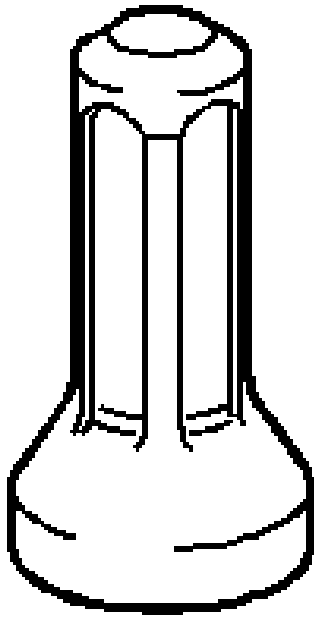

J 25018-A
Clutch Spring Compressor Adapter

2007 Hummer H3

2007 TRANSMISSION Automatic Transmission - 4L60-E/4L65-E/4L70-E - H3

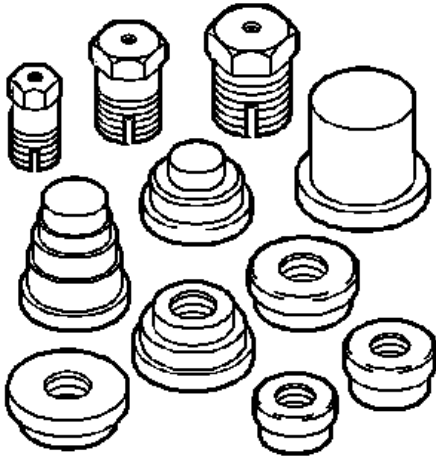

J 25019
Bushings Service Set

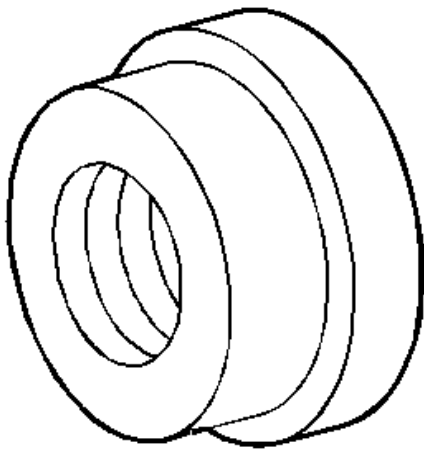

J 25019-4
Direct Clutch Bushing Installer

J 25019-9

2007 Hummer H3

2007 TRANSMISSION Automatic Transmission - 4L60-E/4L65-E/4L70-E - H3

Bushing Installer

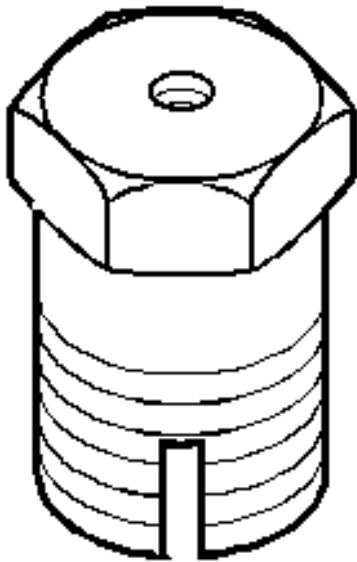
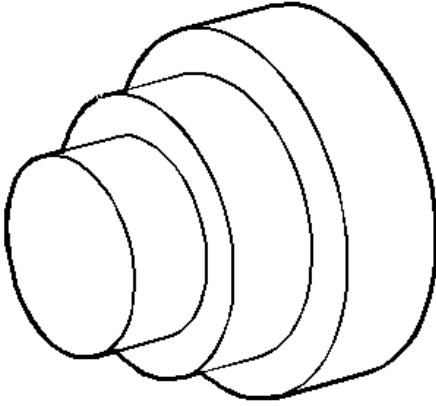

J 25019-16
Bushing Remover

2007 Hummer H3

2007 TRANSMISSION Automatic Transmission - 4L60-E/4L65-E/4L70-E - H3

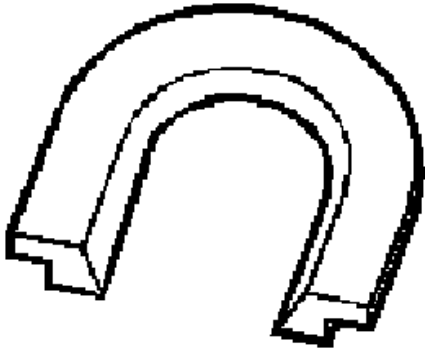

J 25022
End Play Fixture Adapter

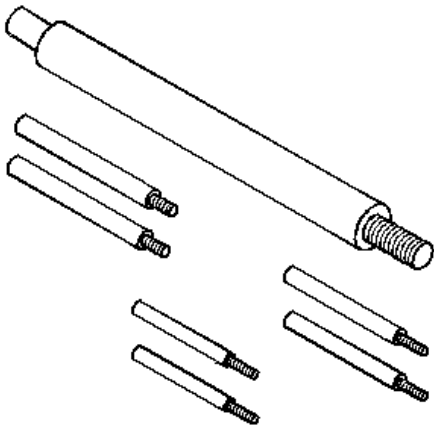

J 25025-B
Dial Indicator Post and Guide Pin Set

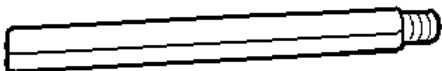

J 25025-1
Dial Indicator Mounting Post

2007 Hummer H3

2007 TRANSMISSION Automatic Transmission - 4L60-E/4L65-E/4L70-E - H3

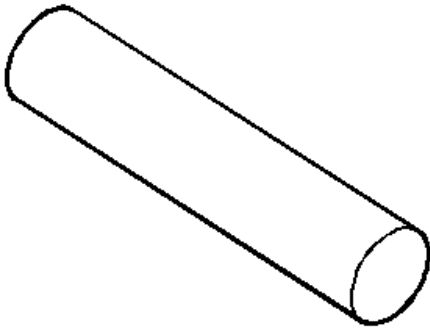

J 25025-5
Dial Indicator Mounting Post M6 x 1.00

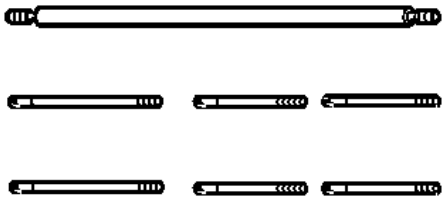

J 25025-7A
Dial Indicator Mounting Post

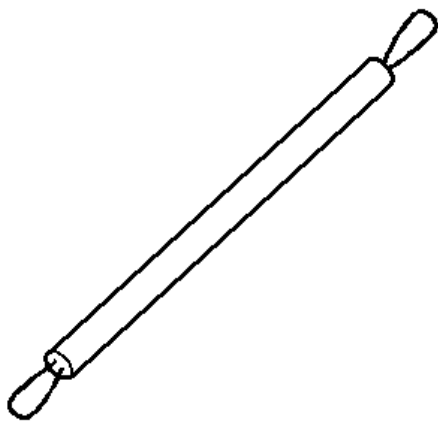

J 26744-A
Seal Installer

2007 Hummer H3

2007 TRANSMISSION Automatic Transmission - 4L60-E/4L65-E/4L70-E - H3

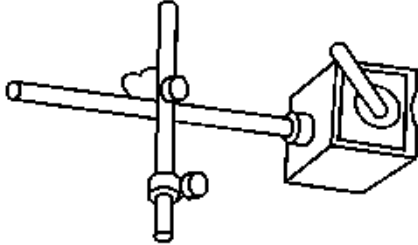

J 26900-13
Magnetic Indicator Base

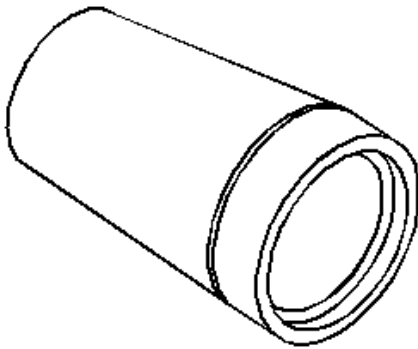

J 28458
Seal Protector Retainer Installer

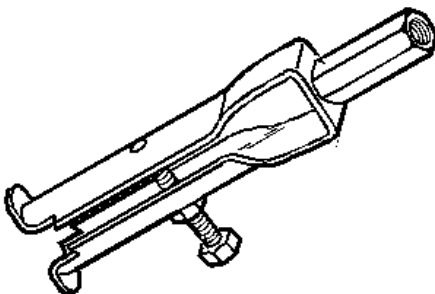

J 29369-2
Bushing and Bearing Remover - 2-3 in

2007 Hummer H3

2007 TRANSMISSION Automatic Transmission - 4L60-E/4L65-E/4L70-E - H3

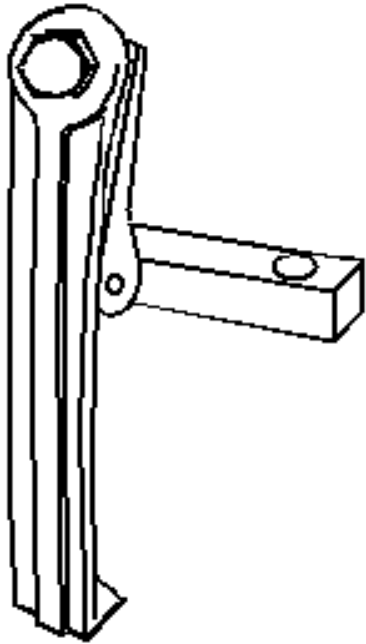

J 29714-A
Servo Cover Depressor

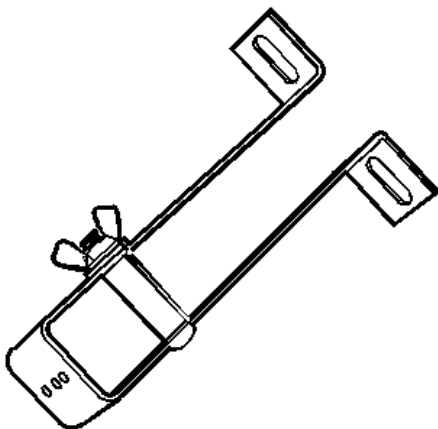

J 29837-A
Output Shaft Support Fixture

2007 Hummer H3

2007 TRANSMISSION Automatic Transmission - 4L60-E/4L65-E/4L70-E - H3

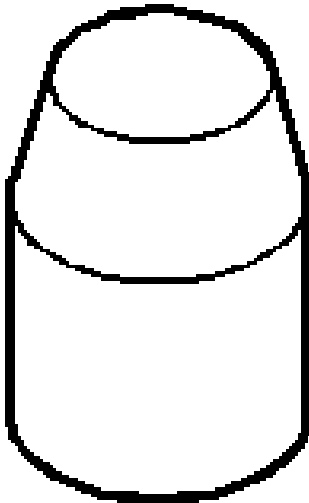

J 29882
Overrun Clutch Seal Protector

J 29883
Forward Clutch Seal Protector

2007 Hummer H3

2007 TRANSMISSION Automatic Transmission - 4L60-E/4L65-E/4L70-E - H3

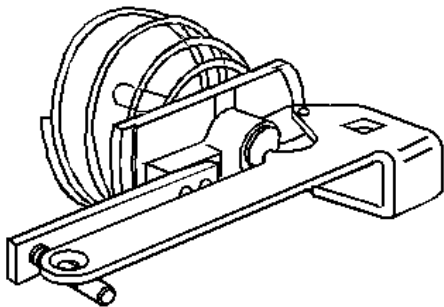
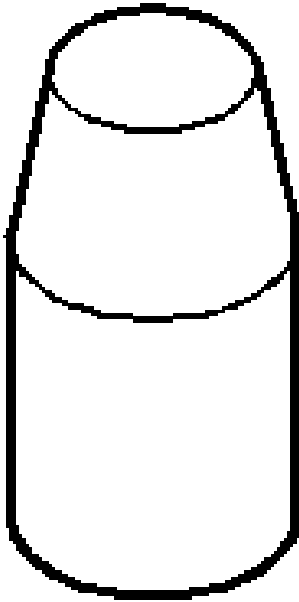

J 33037
2-4 Intermediate Band Apply Pin Gage

2007 Hummer H3

2007 TRANSMISSION Automatic Transmission - 4L60-E/4L65-E/4L70-E - H3

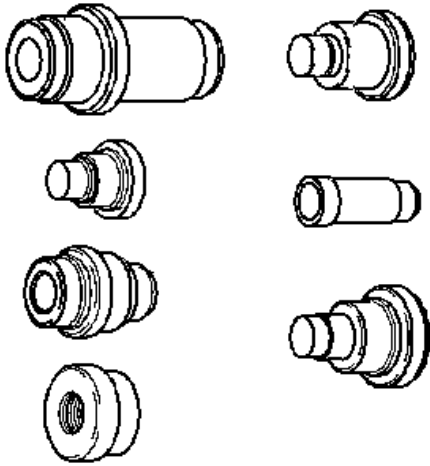

J 34196-B
Transmission Bushing Service Set

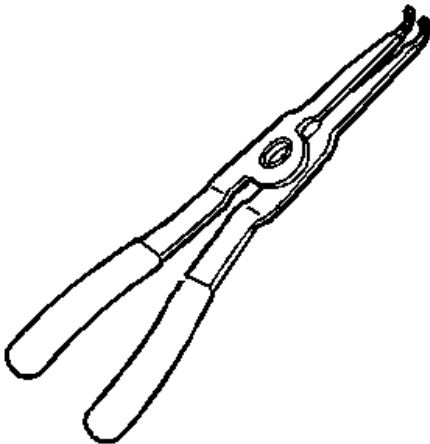

J 34627
Snap Ring Remover and Installer

2007 Hummer H3

2007 TRANSMISSION Automatic Transmission - 4L60-E/4L65-E/4L70-E - H3

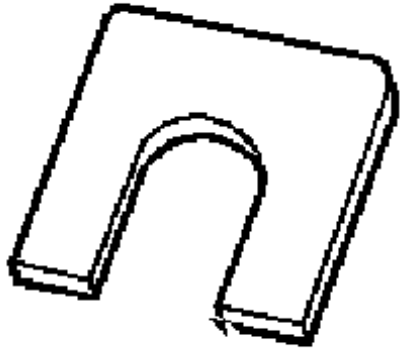

J 34725
End Play Checking Adapter

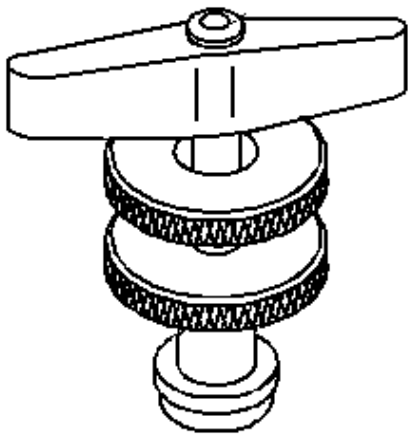

J 35138
Converter End Play Checker

J 35616
GM-Approved Terminal Test Kit

2007 Hummer H3

2007 TRANSMISSION Automatic Transmission - 4L60-E/4L65-E/4L70-E - H3

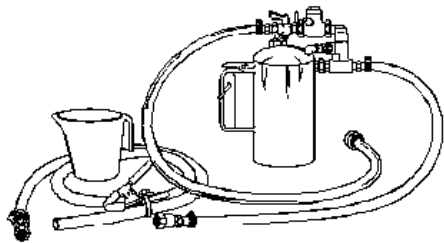
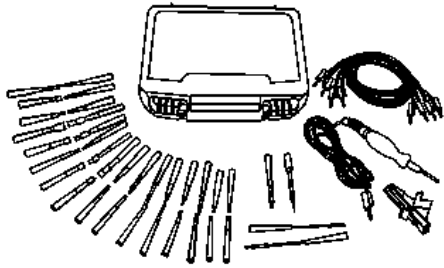

J 35944-A
Transmission Oil Cooler Flusher

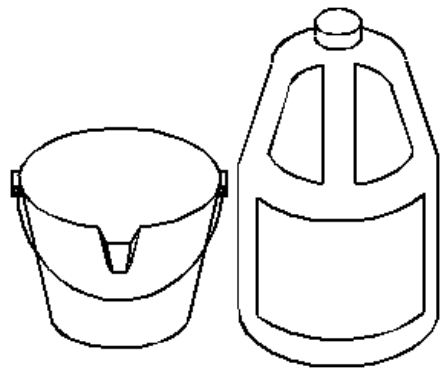

J 35944-22
Transmission Oil Cooler Flushing Fluid

2007 Hummer H3

2007 TRANSMISSION Automatic Transmission - 4L60-E/4L65-E/4L70-E - H3

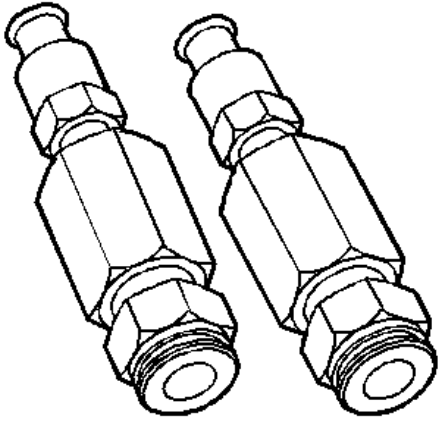

J 35944-200
Cooler Flush Adapters

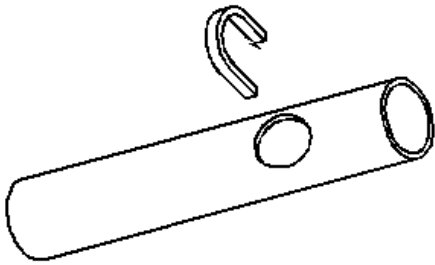

J 36352
Speed Sensor Rotor Installer Kit

J 36352-4
Speed Sensor Rotor Installation Depth C
Washer

2007 Hummer H3

2007 TRANSMISSION Automatic Transmission - 4L60-E/4L65-E/4L70-E - H3

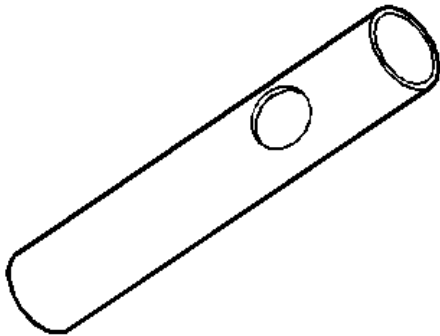
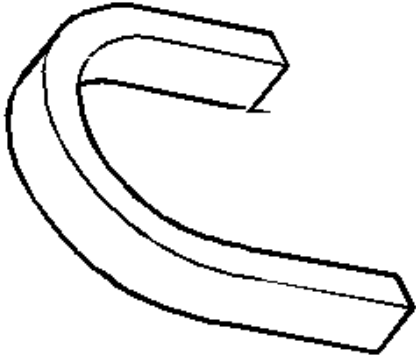

J 36352-6
Speed Sensor Rotor Installation Tube

2007 Hummer H3

2007 TRANSMISSION Automatic Transmission - 4L60-E/4L65-E/4L70-E - H3

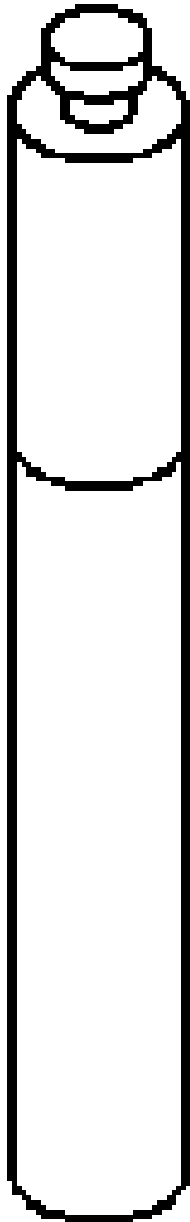

J 36418-1B
Turbine Shaft Seal Installer

2007 Hummer H3

2007 TRANSMISSION Automatic Transmission - 4L60-E/4L65-E/4L70-E - H3

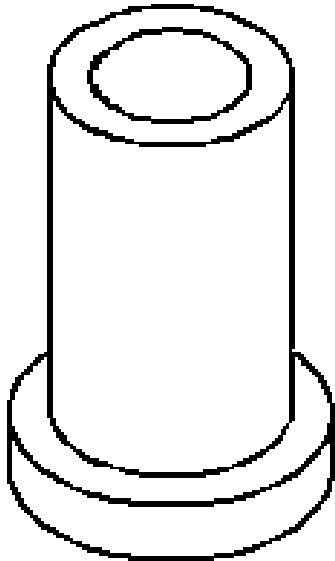

J 36418-2A
Turbine Shaft Seal Sizer

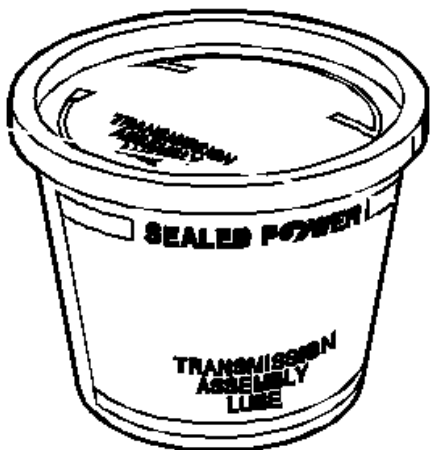

J 36850
Transjel Lubricant

2007 Hummer H3

2007 TRANSMISSION Automatic Transmission - 4L60-E/4L65-E/4L70-E - H3

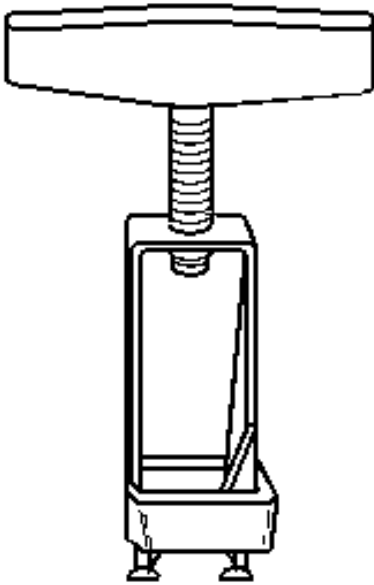

J 37789-A
Oil Pump Remover/Installer

J 38522
Variable Signal Generator

2007 Hummer H3

2007 TRANSMISSION Automatic Transmission - 4L60-E/4L65-E/4L70-E - H3

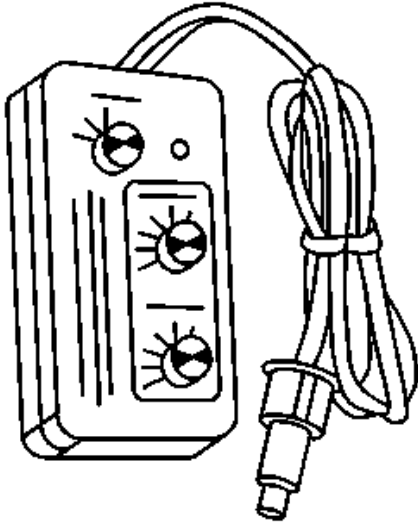

J 38735-3
Pusher

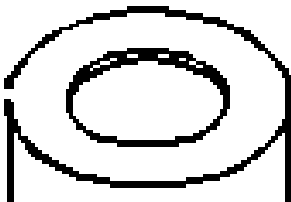

2007 Hummer H3

2007 TRANSMISSION Automatic Transmission - 4L60-E/4L65-E/4L70-E - H3

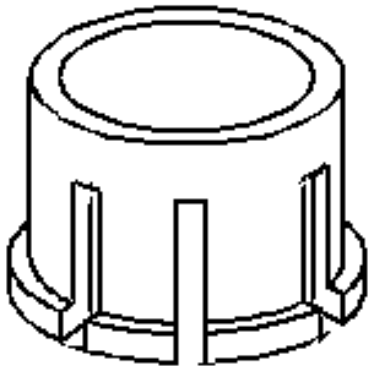

J 39119
Oil Pump Remover/Installer Adapter

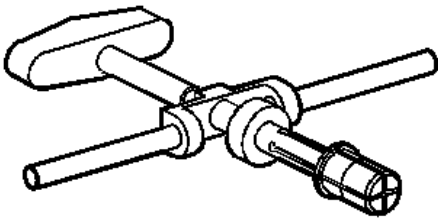

J 39195
Converter End Play Check Tool

J 39855

2007 Hummer H3

2007 TRANSMISSION Automatic Transmission - 4L60-E/4L65-E/4L70-E - H3

Stator Shaft Seal Installer

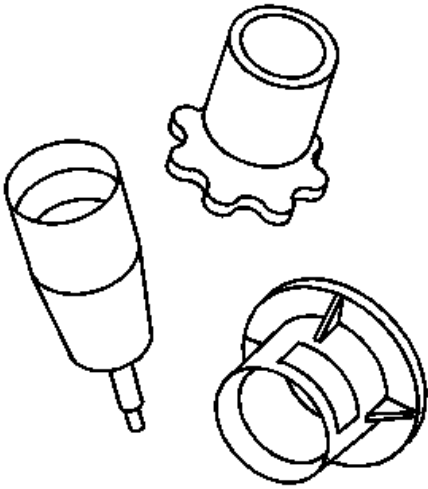

J 41364-A
Park/Neutral Switch Aligner

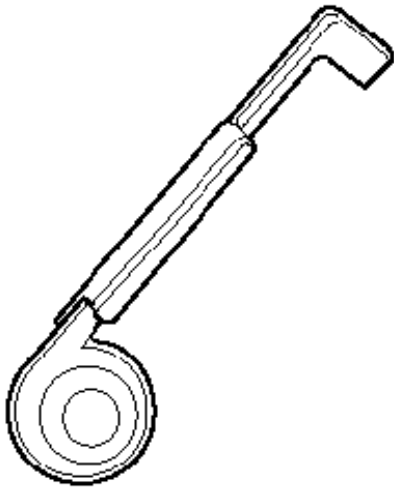

2007 Hummer H3

2007 TRANSMISSION Automatic Transmission - 4L60-E/4L65-E/4L70-E - H3

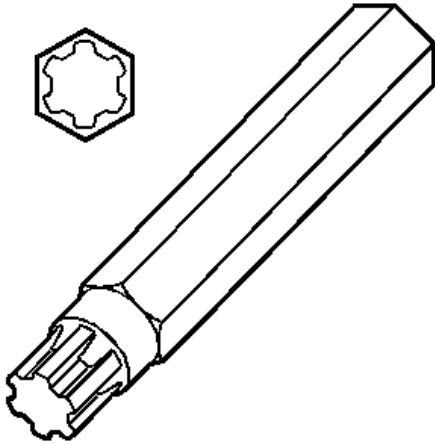

J 41510
T-50 Plus Bit

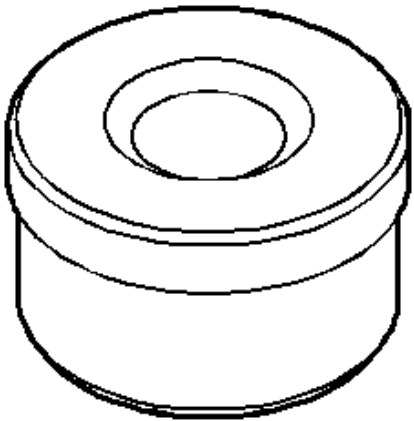

J 41778-1
Pump Body Bushing Installer/Remover

J 41778-2
Pump Body Bushing Position Stop

2007 Hummer H3

2007 TRANSMISSION Automatic Transmission - 4L60-E/4L65-E/4L70-E - H3

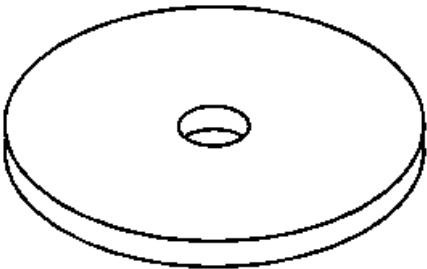
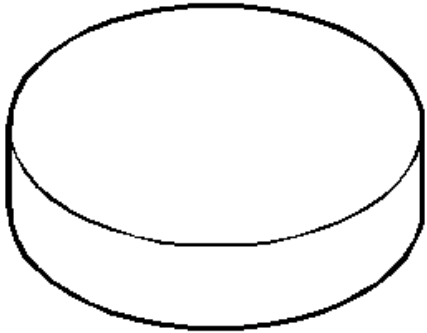

J-42628
Plate

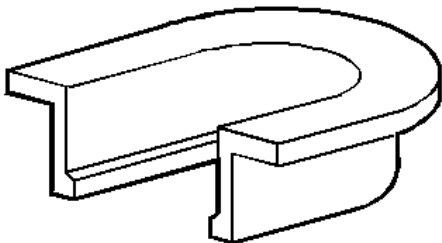

J 43205
End Play Fixture Adapter (300 mm
Converter)

2007 Hummer H3

2007 TRANSMISSION Automatic Transmission - 4L60-E/4L65-E/4L70-E - H3

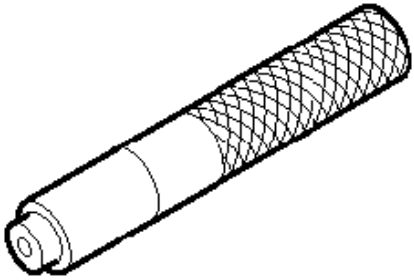

J 43909
Selector Shaft Seal Installer

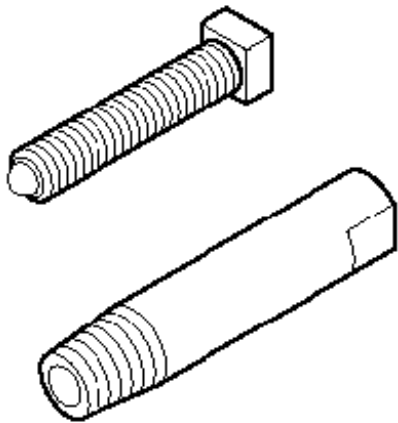

J 43911
Selector Shaft Seal Remover

J 44152
Jumper Harness (20 Pins)

2007 Hummer H3

2007 TRANSMISSION Automatic Transmission - 4L60-E/4L65-E/4L70-E - H3

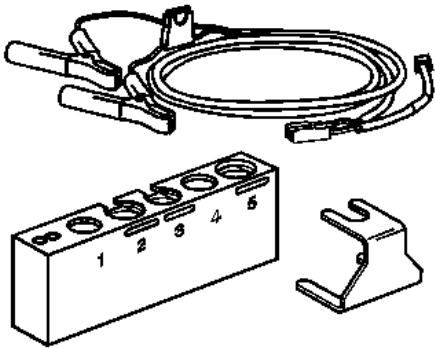
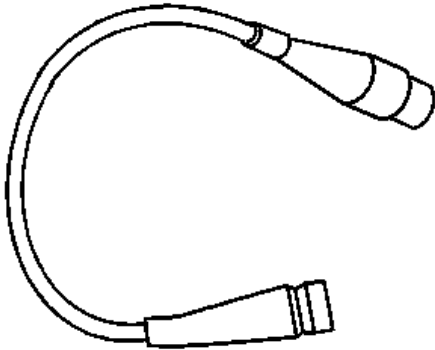

J 44246
Solenoid Testing Kit

J 44571-1
Reverse Input Clutch Piston Installer

2007 Hummer H3

2007 TRANSMISSION Automatic Transmission - 4L60-E/4L65-E/4L70-E - H3

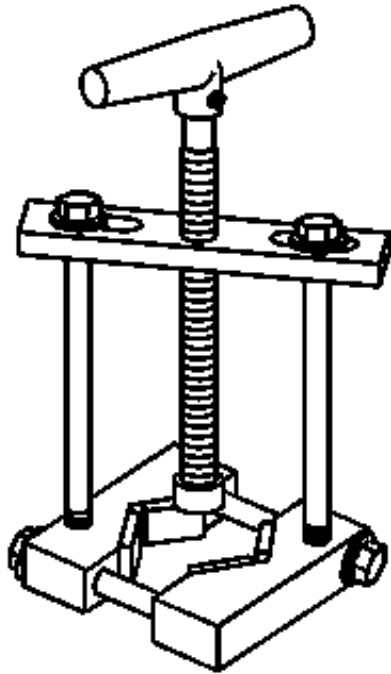
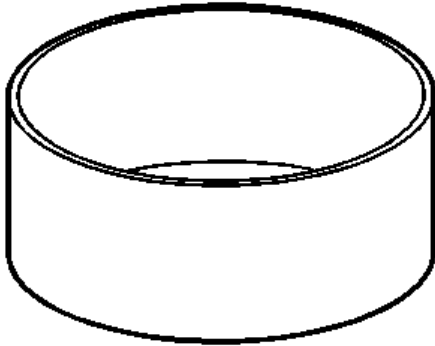

J 45053
Universal Clamp Press

2007 Hummer H3

2007 TRANSMISSION Automatic Transmission - 4L60-E/4L65-E/4L70-E - H3

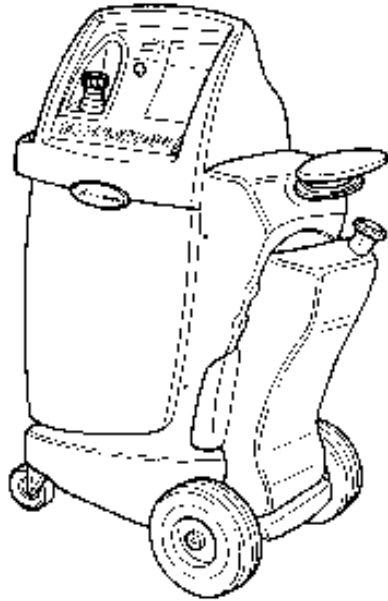

J 45096
Transmission Oil Cooling System Flush and
Flow Test Tool